



**UNITED NATIONS**

# **AGREEMENT**

**CONCERNING THE ADOPTION OF UNIFORM CONDITIONS OF APPROVAL  
AND RECIPROCAL RECOGNITION OF APPROVAL  
FOR MOTOR VEHICLE EQUIPMENT AND PARTS**

**done at Geneva on 20 March 1958**

---

*Addendum 47: Regulation No. 48*

Date of entry into force as an annex to the Agreement:  
1 January 1982

**UNIFORM PROVISIONS CONCERNING THE APPROVAL  
OF VEHICLES WITH REGARD TO THE INSTALLATION OF LIGHTING AND  
LIGHT-SIGNALLING DEVICES**

---

Regulation No. 48

UNIFORM PROVISIONS CONCERNING THE APPROVAL OF  
 VEHICLES WITH REGARD TO THE INSTALLATION OF  
 LIGHTING AND LIGHT-SIGNALLING DEVICES

CONTENTS

pages

REGULATION

1.	Scope .....	1
2.	Definitions .....	1
3.	Application for approval .....	6
4.	Approval .....	7
5.	General specifications .....	9
6.	Individual specifications .....	14
7.	Modifications of the vehicle type or of the installation of its lighting and light-signalling devices .....	32
8.	Conformity of production .....	33
9.	Penalties for non-conformity of production .....	33
10.	Production definitely discontinued .....	33
11.	Names and addresses of the technical services responsible for conducting approval tests, and of administrative departments .....	33

ANNEXES

<u>Annex 1</u>	Communication concerning the approval (or refusal or withdrawal of approval or production definitely discontinued) of a vehicle type with regard to the installation of lighting and light- signalling devices, pursuant to Regulation No. 48
<u>Annex 2</u>	Arrangements of approval marks
<u>Annex 3</u>	Definition of the illuminating surface
<u>Annex 4</u>	Forward visibility of red lights and rearward visibility of white lights
<u>Annex 5</u>	States of loading to be taken into consideration in determining variations in the vertical orientation of the passing beam

Regulation No. 48

UNIFORM PROVISIONS CONCERNING THE APPROVAL OF  
VEHICLES WITH REGARD TO THE INSTALLATION OF  
LIGHTING AND LIGHT-SIGNALLING DEVICES

1. SCOPE

This Regulation applies to the approval of power-driven vehicles intended for use on the road, with or without bodywork, with not less than four wheels and a maximum design speed exceeding 25 km/h, and of their trailers, with the exception of vehicles which run on rails, agricultural or forestry tractors and machinery, and public works vehicles.

2. DEFINITIONS

For the purposes of this Regulation

- 2.1. "approval of a vehicle" means the approval of a vehicle type with regard to the number and mode of installation of the lighting and light-signalting devices;
- 2.2. "vehicle type" means a category of vehicles which do not differ from each other in such essential respects as
- 2.2.1. the dimensions and external lines of the vehicle;
- 2.2.2. the number and position of the devices;
- 2.2.3. the following shall likewise not be deemed to be "vehicles of a different type":
- 2.2.3.1. vehicles which differ within the meaning of paragraphs 2.2.1. and 2.2.2. above but not in such a way as to entail a change in the kind, number, position and geometric visibility of the lamps prescribed for the vehicle type in question; and
- 2.2.3.2. vehicles on which lamps approved under one of the Regulations annexed to the 1958 Agreement, or lamps allowed in the country in which the vehicles are registered, are fitted or are absent where their fitting is optional;
- 2.3. "transverse plane" means a vertical plane perpendicular to the median longitudinal plane of the vehicle;
- 2.4. "unladen vehicle" means a vehicle without crew, passengers or load, but with a full supply of fuel and the tools normally carried, and the driver rated at 75 kg;

- 2.5. "laden vehicle" means a vehicle loaded to its technically permissible maximum weight, as stated by the manufacturer who shall also fix the distribution of this weight between the axles in accordance with the method described in annex 5;
- 2.6. "lamp" means a device designed to illuminate the road or to emit a luminous signal; rear-registration-plate illuminating devices and reflex reflectors shall likewise be regarded as lamps;
- 2.6.1. "equivalent lamps" means lamps having the same function and approved under the same Regulations annexed to the 1958 Agreement or in conformity with the same requirements; such lamps may have different characteristics from those of the lamps with which the vehicle is equipped at the time of approval, on condition that they satisfy the requirements of this Regulation;
- 2.6.2. "independent lamps" means lamps having separate lenses, separate light sources and separate lamp bodies;
- 2.6.3. "grouped lamps" means devices having separate lenses and separate light sources, but a common lamp body;
- 2.6.4. "combined lamps" means devices having separate lenses but a common light source and a common lamp body;
- 2.6.5. "reciprocally incorporated lamps" means devices having separate light sources (or a single light source operating in different ways), totally or partially common lenses and a common lamp body;
- 2.6.6. "concealable illuminating lamp" means a headlamp capable of being partly or completely hidden when not in use. This result may be achieved by means of a movable cover, by movement of the headlamp, or by any other suitable means; the term "vanishing lamp" is used more particularly to describe a lamp which, by its movement, can be concealed inside the bodywork;
- 2.6.7. "driving lamp" means the lamp used to illuminate the road over a long distance ahead of the vehicle;
- 2.6.8. "passing lamp" means the lamp used to illuminate the road ahead of the vehicle without causing undue dazzle or discomfort to oncoming drivers and other road-users;
- 2.6.9. "direction-indicator lamp" means the lamp used to indicate to other road-users that the driver intends to change direction to the right or to the left;

- 2.6.10. "stop lamp" means the lamp used to indicate to other road-users to the rear of the vehicle that its driver is applying the service brake;
- 2.6.11. "rear-registration-plate illuminating device" means the device used to illuminate the space reserved for the rear registration plate; such a device may consist of several optical components;
- 2.6.12. "front position (side) lamp" means the lamp used to indicate the presence and the width of the vehicle when viewed from the front;
- 2.6.13. "rear position (side) lamp" means the lamp used to indicate the presence and the width of the vehicle when viewed from the rear;
- 2.6.14. "reflex reflector" means a device used to indicate the presence of a vehicle by the reflection of light from a light source not connected with the vehicle, the observer being situated near that source; for the purposes of this Regulation, the following are not considered as reflex reflectors:
- retro-reflecting number plates;
  - the retro-reflecting signals mentioned in the European Agreement concerning the International Carriage of Dangerous Goods by Road (ADR);
  - other plates and retro-reflecting signals which must be used to comply with specifications of a Party to the Agreement applying this Regulation for use as regards certain categories of vehicles or certain methods of operation;
- 2.6.15. "hazard warning signal" means the simultaneous operation of all of a vehicle's direction-indicator lamps to show that the vehicle temporarily constitutes a special danger to other road-users;
- 2.6.16. "front fog lamp" means the lamp used to improve the illumination of the road in case of fog, snowfall, rainstorms or dust clouds;
- 2.6.17. "rear fog lamp" means a lamp used to make the vehicle more easily visible from the rear in dense fog;
- 2.6.18. "reversing lamp" means the lamp used to illuminate the road to the rear of the vehicle and to warn other road-users that the vehicle is reversing or about to reverse;
- 2.6.19. "parking lamp" means a lamp which is used to draw attention to the presence of a stationary vehicle in a built-up area; in these circumstances it replaces the position (side) lamps;

- 2.6.20. "end-outline marker lamp" means a lamp fitted near to the extreme outer edges and as close as possible to the top of the vehicle and intended to indicate clearly the vehicle's over-all width; in the case of certain power-driven vehicles and trailers, this lamp is intended to complement the vehicle's position (side) lamps and draw special attention to its outline;
- 2.7. "illuminating surface" (see annex 3);
- 2.7.1. "illuminating surface of a lighting device" (paragraphs 2.6.7., 2.6.8., 2.6.16. and 2.6.18.) means the orthogonal projection of the full aperture of the reflector on a transverse plane; if the lamp glass(es) extends (extend) over only a part of the full aperture of the reflector, then only the projection of that part is considered. In the case of a passing lamp, the illuminating surface is limited on the side of the cut-off by the apparent projection of the line of the cut-off on the lens. If the reflector and glass are adjustable, the mean adjustment shall be used;
- 2.7.2. "illuminating surface of a light-signalling device other than a reflex reflector" (paragraphs 2.6.9. to 2.6.13., 2.6.15., 2.6.17., 2.6.19. and 2.6.20.) means the orthogonal projection of the lamp on a plane perpendicular to its axis of reference and in contact with the transparent outer surface of the lamp, such projection being bounded by the covering of the screen edges situated in that plane and each allowing only 98 per cent of the total intensity of the light to subsist in the direction of the axis of reference; for the purposes of determining the lower, upper and lateral edges of the lamp, only screens having a horizontal or a vertical edge shall be considered;
- 2.7.3. "illuminating surface of a reflex reflector" (paragraph 2.6.14.) means the illuminating surface of a reflex reflector in a plane perpendicular to its axis of reference and delimited by planes contiguous to the outermost parts of the reflex reflector's optical system and parallel to that axis; for the purposes of determining the lower, upper and lateral edges of the device, only horizontal and vertical planes shall be considered;
- 2.8. "exterior light-emitting surface" in a specific direction of observation means the orthogonal projection of the light-emitting surface on a plane perpendicular to the direction of observation;

- 2.9. "axis of reference" (or "reference axis") means the characteristic axis of the light signal determined by the manufacturer (of the lamp) for use as the direction of reference ( $H = 0^\circ$ ,  $V = 0^\circ$ ) for angles of field for photometric measurements and for installing the lamp on the vehicle;
- 2.10. "centre of reference" means the intersection of the axis of reference with the exterior light-emitting surface; it is specified by the manufacturer of the lamp;
- 2.11. "angles of geometric visibility" means the angles which determine the minimum solid-angle zone in which the exterior light-emitting surface of the lamp must be visible; this solid-angle zone is defined by the segments of a sphere whose centre coincides with the centre of reference of the lamp and whose equator is parallel to the carriageway; the segments are determined from the axis of reference; the horizontal angles  $\beta$  correspond to longitude, the vertical angles  $\alpha$  to latitude; within the angles of geometric visibility there must be no obstacle to the propagation of light from any part of the exterior light-emitting surface of the lamp, no account is taken of obstacles existing at the time of approval, where required, of the lamp;
- 2.12. "extreme outer edge", on either side of the vehicle, means the plane parallel to the median longitudinal plane of the vehicle and touching the lateral extremity of the vehicle, disregarding the projection or projections
- 2.12.1. of tyres near their point of contact with the ground, and of connections for tyre-pressure gauges;
- 2.12.2. of any anti-skid devices mounted on the wheels;
- 2.12.3. of rear-view mirrors;
- 2.12.4. of side direction indicators, front and rear position (side) lamps end-outline marker lamps and parking lamps; and
- 2.12.5. of Customs seals affixed to the vehicle, and of devices for securing and protecting such seals;
- 2.13. "over-all width" means the distance between the two vertical planes defined in paragraph 2.12. above.
- 2.14. The following shall be deemed to be:
- 2.14.1. "single-lamp": any assembly of two or more lamps, whether identical or not, having the same function and emitting a light of the same colour, which is constituted by devices the projection of whose aggregate

light-emitting surfaces on a transverse plane occupies not less than 60 per cent of the area of the smallest rectangle circumscribing the projections of the said light-emitting surfaces, provided that such assembly is approved as a single lamp where approval is required; the possibility of assembling lamps in this way does not apply to driving lamps, passing lamps or front fog lamps;

2.14.2. "two lamps" or "an even number of lamps": a single light-emitting surface in the shape of a band or strip if such band or strip is placed symmetrically in relation to the median longitudinal plane of the vehicle, extends on both sides to within at least 0.4 m of the extreme outer edge of the vehicle, and is not less than 0.8 m long; the illumination of such surface shall be provided by not less than two light sources placed as close as possible to its ends; the light-emitting surface may be constituted by a number of juxtaposed elements on condition that the projections of the several individual light-emitting surfaces on a transverse plane occupy not less than 60 per cent of the area of the smallest rectangle circumscribing the projections of the said individual light-emitting surfaces;

2.15. "distance between two lamps" oriented in the same direction means the distance between the orthogonal projections, on a plane perpendicular to the axis of reference of the perimeters of the two illuminating surfaces as defined in paragraph 2.7.;

2.16. "operating tell-tale" means a light or auditory device showing that a device has been switched on and is operating correctly or not;

2.17. "circuit-closed tell-tale" means a lamp showing that a device has been switched on, but not showing whether it is operating correctly or not;

2.18. "optional lamp" means a lamp, the presence of which is left to the discretion of the manufacturer.

### 3. APPLICATION FOR APPROVAL

3.1. The application for approval of a vehicle type with regard to the installation of its lighting and light-signalling devices shall be submitted by the vehicle manufacturer or his duly accredited representative.

3.2. It shall be accompanied by the following documents and particulars in triplicate:



- 3.2.1. a description of the vehicle type with regard to the items mentioned in paragraphs 2.2.1. and 2.2.2. above, together with the restrictions on loading, particularly the maximum permissible load in the boot;
- 3.2.2. a list of the devices intended by the manufacturer to form the lighting and light-signalling equipment; the list may include several types of device for each function; each type shall be duly identified (national or international approval mark, if approved, name of manufacturer, etc.); in addition, the list may include in respect of each function the additional annotation "or equivalent devices";
- 3.2.3. a diagram of the lighting and light-signalling installation as a whole, showing the position of the various devices on the vehicle; and
- 3.2.4. a drawing or drawings of each lamp showing the illuminating surface as defined in paragraph 2.7. above.
- 3.3. An unladen vehicle fitted with a complete set of lighting and light-signalling equipment, as prescribed in paragraph 3.2.2. above, and representative of the vehicle type to be approved shall be submitted to the technical service conducting approval tests.
4. APPROVAL
- 4.1. If the vehicle type submitted for approval pursuant to this Regulation meets the requirements of the Regulation in respect of all the devices specified in the list, approval of that vehicle type shall be granted.
- 4.2. An approval number shall be assigned to each type approved. Its first two digits (at present 00 for the Regulation in its original form) shall indicate the series of amendments incorporating the most recent major technical amendments made to the Regulation at the time of issue of the approval. The same Contracting Party shall not assign this number to another vehicle type or to the same vehicle type submitted with equipment not specified in the list referred to in paragraph 3.2.2. above, subject to the provisions of paragraph 7 of this Regulation.
- 4.3. Notice of approval or of refusal of approval of a vehicle type pursuant to this Regulation shall be communicated to the Parties to the Agreement which apply this Regulation by means of a form conforming to the model in annex 1 to this Regulation and of diagrams supplied by the applicant for approval of the installation as referred to in paragraph 3.2.3. in a format not exceeding A4 (210 x 297 mm) or folded to that format and on an appropriate scale.

- 4.4. There shall be affixed, conspicuously and in a readily accessible place specified on the approval form, to every vehicle conforming to a vehicle type approved under this Regulation, an international approval mark consisting of:
- 4.4.1. a circle surrounding the letter "E" followed by the distinguishing number of the country which has granted approval;<sup>1/</sup>
- 4.4.2. the number of this Regulation, followed by the letter "R", a dash and the approval number to the right of the circle prescribed in paragraph 4.4.1., and
- 4.4.3. an additional symbol, separated from the number of this Regulation by a vertical stroke and representing the value of the initial orientation of the passing lights specified by the manufacturer and referred to in paragraph 6.2.5.1. below.
- 4.5. If the vehicle conforms to a vehicle type approved, under one or more other Regulations annexed to the Agreement, in the country which has granted approval under this Regulation, the symbol prescribed in paragraph 4.4.1. need not be repeated; in such a case the Regulation and approval numbers and the additional symbols of all the Regulations under which approval has been granted in the country which has granted approval under this Regulation shall be placed in vertical columns to the right of the symbol prescribed in paragraph 4.4.1.
- 4.6. The approval mark shall be clearly legible and shall be indelible.
- 4.7. The approval mark shall be placed close to or on the vehicle data plate affixed by the manufacturer.
- 4.8. Annex 2 to this Regulation gives examples of arrangements of approval marks.

---

<sup>1/</sup> 1 for the Federal Republic of Germany, 2 for France, 3 for Italy, 4 for the Netherlands, 5 for Sweden, 6 for Belgium, 7 for Hungary, 8 for Czechoslovakia, 9 for Spain, 10 for Yugoslavia, 11 for the United Kingdom, 12 for Austria, 13 for Luxembourg, 14 for Switzerland, 15 for the German Democratic Republic, 16 for Norway, 17 for Finland, 18 for Denmark, 19 for Romania, 20 for Poland and 21 for Portugal. Subsequent numbers shall be assigned to other countries in the chronological order in which they ratify the Agreement concerning the Adoption of Uniform Conditions of Approval and Reciprocal Recognition of Approval for Motor Vehicle Equipment and Parts, or in which they accede to that Agreement, and the numbers thus assigned shall be communicated by the Secretary-General of the United Nations to the Contracting Parties to the Agreement.

5. GENERAL SPECIFICATIONS

- 5.1. The lighting and light-signalling devices shall be so fitted that in normal conditions of use, and notwithstanding the vibrations to which they may be subjected, they retain the characteristics prescribed by this Regulation and enable the vehicle to comply with the requirements of this Regulation. In particular, it shall not be possible for the lamps to be inadvertently maladjusted.
- 5.2. The illuminating lamps described in paragraphs 2.6.7., 2.6.8. and 2.6.16. shall be so installed that correct adjustment of their orientation can easily be carried out.
- 5.3. For all light-signalling devices, including those mounted on the side walls, the reference axis of the lamp when fitted to the vehicle shall be parallel to the bearing plane of the vehicle on the road; in addition, it shall be perpendicular to the median longitudinal plane of the vehicle in the case of side reflex reflectors and parallel to that plane in the case of all other light-signalling devices. A tolerance of  $\pm 3^\circ$  shall be allowed in each direction. In addition, if specifications for fitting are provided by the manufacturer they shall be complied with.
- 5.4. In the absence of specific instructions, the height and orientation of the lamps shall be verified with the vehicle unladen and placed on a flat horizontal surface.
- 5.5. In the absence of specific instructions lamps constituting a pair shall:
- 5.5.1. be mounted symmetrically in relation to the median longitudinal plane;
- 5.5.2. be symmetrical to one another in relation to the median longitudinal plane;
- 5.5.3. satisfy the same colorimetric requirements; and
- 5.5.4. have substantially identical photometric characteristics.
- 5.6. On vehicles whose external shape is asymmetrical the above requirements shall be satisfied so far as is possible.
- 5.7. Lamps having different functions may be independent or be grouped, combined or reciprocally incorporated in one device, on condition that each such lamp satisfies the requirements applicable to it.
- 5.8. The maximum height above ground shall be measured from the highest point and the minimum height from the lowest point of the illuminating surface.
- 5.9. In the absence of specific instructions, no lamps other than direction-indicator lamps and the vehicle-hazard warning signal shall be flashing lamps.

- 5.10. No red light shall be visible towards the front and no white light other than the reversing light shall be visible towards the rear. Compliance with this requirement shall be verified as shown hereunder (see drawing in annex 4):
- 5.10.1. visibility of red light towards the front: red light must not be directly visible to an observer moving in zone 1 of a transverse plane situated 25 m forward of the foremost point of the vehicle;
- 5.10.2. visibility of white light towards the rear: white light must not be directly visible to an observer moving in zone 2 of a transverse plane situated 25 m rearward of the rearmost point on the vehicle;
- 5.10.3. in their respective planes, the zones 1 and 2 explored by the eye of the observer are bounded:
- 5.10.3.1. in height, by two horizontal planes 1 m and 2.2 m respectively above the ground;
- 5.10.3.2. in width, by two vertical planes which, forming to the front and to the rear respectively an angle of 15° outwards from the vehicle's median longitudinal plane, pass through the point or points of contact of vertical planes parallel to the vehicle's median longitudinal plane delimiting the vehicle's over-all width; if there are several points of contact, the foremost shall correspond to the forward plane and the rearmost to the rearward plane.
- 5.11. The electrical connections shall be such that the front position (side) lamps, the rear position (side) lamps, the rear-registration-plate illuminating device and the end-outline marker lamps cannot be switched on or off otherwise than simultaneously.
- 5.12. In the absence of specific instructions the electrical connections shall be such that the driving lamps, the passing lamps and the front and rear fog lamps cannot be switched on unless the lamps referred to in paragraph 5.11. above are likewise switched on. This requirement need not, however, be satisfied in the case of driving lamps and passing lamps where their luminous warnings consist in switching on the passing lamps intermittently at short intervals or in switching on the driving lamps intermittently or in switching on the passing lamps and driving lamps alternately at short intervals.

5.13. Tell-tale lamps

Where a "circuit-closed" tell-tale is prescribed by this Regulation it may be replaced by an "operating" tell-tale.

5.14. Concealable lamps

- 5.14.1. The concealment of lamps shall be prohibited, with the exception of the driving lamps, the passing lamps and the front fog lamps, which may be concealed when they are not in use.
- 5.14.2. An illuminating lamp in the position of use shall remain in that position even if the power for manipulating the lamp fails, either alone or in conjunction with one of the following faults: accidental opening of the supply circuit; earth leakage; defects in solenoids; defects in hydraulic or compressed-air lines, bowden cables, flexible leads or other components controlling or transmitting the energy intended to actuate the concealment device.
- 5.14.3. In the event of a defect in the concealment control, a concealed lighting device shall be capable of being moved into the position of use without the use of tools.
- 5.14.4. It shall be possible to move lighting devices into the position of use and switch them on by means of a single control; it shall also be possible to move them into the position of use without switching them on. However, in the case of grouped driving and passing lamps, the control referred to above is required only to activate the passing lamps.
- 5.14.5. It shall not be possible deliberately to stop, from the driver's seat, the movement of switched-on lighting devices before they reach the position of use. Where there is a risk that other road users may be dazzled by the movement of the headlamps it shall not be possible to switch on the headlamps before they have reached their final position.
- 5.14.6. A lighting device shall at temperatures from  $-30^{\circ}\text{C}$  to  $+50^{\circ}\text{C}$  be capable of reaching the fully-open position within three seconds after initial operation of the control.
- 5.15. The colours of the light emitted by the lamps or reflectors referred to in this Regulation shall be as follows:
- |                           |                           |
|---------------------------|---------------------------|
| driving lamp:             | white or selective yellow |
| passing lamp:             | white or selective yellow |
| direction-indicator lamp: | amber                     |
| stop lamp:                | red                       |

rear-registration-plate	
illuminating device:	white
front position (side) lamp:	white (selective yellow shall be permitted if this light is incorporated in a selective yellow headlight)
rear position (side) lamp:	red
rear reflex reflector,	
non-triangular:	red
rear reflex reflector,	
triangular:	red
front reflex reflector,	
non-triangular: <sup>1/</sup>	identical to incident light
side reflex reflector,	
non-triangular:	amber
hazard warning signal:	amber
front fog lamp:	white or yellow
rear fog lamp:	red
reversing lamp:	white
parking lamp:	white at the front, red at the rear, amber if the parking lamps are incorporated in the side direction-indicator lamps
end-outline marker lamp:	white at the front, red at the rear

- 5.16. Every vehicle submitted for approval pursuant to this Regulation shall be equipped with the following lighting and light-signalling devices:
- 5.16.1. driving lamps (paragraph 6.1.) in the case of power-driven vehicles only;
  - 5.16.2. passing lamps (paragraph 6.2.) in the case of power-driven vehicles only;
  - 5.16.3. direction-indicator lamps (paragraph 6.3.) in the case of power-driven vehicles and trailers;
  - 5.16.4. stop lamps (paragraph 6.4.) in the case of power-driven vehicles and trailers;
  - 5.16.5. rear-registration-plate illuminating device (paragraph 6.5.), in the case of power-driven vehicles and trailers;

---

<sup>1/</sup> Also known as white or colourless reflector.

- 5.16.6. position (side) lamps -
  - 5.16.6.1. front (paragraph 6.6.), in the case of power-driven vehicles and trailers if the over-all width of the latter is more than 1.6 m;
  - 5.16.6.2. rear (paragraph 6.7.), in the case of power-driven vehicles and trailers;
- 5.16.7. rear reflex reflectors -
  - 5.16.7.1. non-triangular (paragraph 6.8.), in the case of power-driven vehicles only;
  - 5.16.7.2. triangular (paragraph 6.9.), in the case of trailers only;
- 5.16.8. front reflex reflectors (paragraph 6.10.); in the case of trailers only;
- 5.16.9. side reflex reflectors (paragraph 6.11.), in the case of power-driven vehicles with an over-all length of more than 6 m, (other than those in category  $M_1$ ) and all trailers;
- 5.16.10. hazard warning signal (paragraph 6.12.), in the case of power-driven vehicles and trailers;
- 5.16.11. rear fog lamps (paragraph 6.14.), in the case of power-driven vehicles and trailers;
- 5.16.12. reversing lamps (paragraph 6.15.), in the case of power-driven vehicles only;
- 5.16.13. end-outline marker lamps (paragraph 6.17.), in the case of power-driven vehicles and trailers with an over-all width of more than 2.10 m.
- 5.17. It may, in addition, be equipped with the following lighting and light-signalling devices:
  - 5.17.1. front fog lamps (paragraph 6.13.), in the case of power-driven vehicles only;
  - 5.17.2. front position (side) lamps in the case of trailers which are not more than 1,600 mm wide;
  - 5.17.3. parking lamps (paragraph 6.16.), in the case of power-driven vehicles, of which the length does not exceed 6 m and the width 2 m. Prohibited on all other vehicles;
  - 5.17.4. side reflex reflectors (paragraph 6.11.), in the case of power-driven vehicles in category  $M_1$ , and power-driven vehicles, other than those in category  $M_1$ , the length of which does not exceed 6 m;
  - 5.17.5. front reflex reflectors (paragraph 6.10.), in the case of power-driven vehicles.

6. INDIVIDUAL SPECIFICATIONS

6.1. DRIVING LAMP

6.1.1. Number

Two or four.

6.1.2. Arrangement

No special requirement.

6.1.3. Position

6.1.3.1. In width: the outer edges of the illuminating surface shall in no case be closer to the extreme outer edge of the vehicle than the outer edges of the illuminating surface of the passing lamps.

6.1.3.2. In height: no special requirement.

6.1.3.3. In length: forward of the front axle of the vehicle and fitted in such a way that the light emitted does not cause discomfort to the driver either directly, or indirectly through the rear-view mirrors and/or other reflecting surfaces of the vehicle.

6.1.4. Geometric visibility

The visibility of the illuminating surface, including its visibility in areas which do not appear to be illuminated in the direction of observation considered, shall be ensured within a divergent space defined by generating lines based on the perimeter of the illuminating surface and forming an angle of not less than 5° with the axis of reference of the headlamp.

6.1.5. Orientation

Forwards.

Apart from the devices necessary to maintain correct adjustment, and when there are two pairs of driving lamps, one pair, consisting of headlamps functioning as driving lamps only, may swivel, according to the angle of lock of the steering, about a substantially vertical axis.

6.1.6. May be "grouped" with the passing lamp and the other front lamps.

6.1.7. May not be "combined" with any other lamp.

6.1.8. May be "reciprocally incorporated"

6.1.8.1. with the passing lamps, unless the driving headlamp swivels according to the angle of lock of the steering;

6.1.8.2. with the front position (side) lamps;

6.1.8.3. with the front fog lamps;

6.1.8.4. with the parking lamp.



6.1.9. Electrical connections

The driving lamps may be switched on either simultaneously or in pairs. For changing over from the passing beam to the driving beam at least one pair of driving headlamps shall be switched on. For changing over from the driving beam to the passing beam all driving headlamps shall be switched off simultaneously. The passing lamps may remain switched on at the same time as the driving lamps.

6.1.10. "Circuit-closed" tell-tale

Mandatory.

6.1.11. Other requirements

The aggregate maximum intensity of the driving beams which can be switched on simultaneously shall not exceed 225,000 cd. This maximum intensity shall be obtained by adding together the individual maximum intensities measured at the time of component type approval and shown on the relevant approval forms.

6.2. PASSING LAMP

6.2.1. Number

Two.

6.2.2. Arrangement

No special requirement.

6.2.3. Position

6.2.3.1. In width: that edge of the illuminating surface which is farthest from the vehicle's median longitudinal plane shall be not more than 400 mm from the extreme outer edge of the vehicle.

The inner edges of the illuminating surfaces shall be not less than 600 mm apart.

6.2.3.2. In height: not less than 500 mm and not more than 1,200 mm above the ground.

6.2.3.3. In length: at the front of the vehicle. This requirement shall be deemed to be satisfied if the light emitted does not cause discomfort to the driver either directly, or indirectly through the rear-view mirrors and/or other reflecting surfaces of the vehicle.

6.2.4. Geometric visibility

Defined by angles  $\alpha$  and  $\beta$  as specified in paragraph 2.11.:

$\alpha$  = 15° upwards and 10° downwards;

$\beta$  = 45° outwards and 10° inwards.

Within this field, almost the whole light-emitting surface of the lamp shall be visible. The presence of partitions or other items of equipment near the headlamp shall not give rise to secondary effects causing discomfort to other road users.

6.2.5. Orientation

Forwards.

- 6.2.5.1. The vertical orientation of the passing beam measured in the static condition and in all the states of loading defined in annex 5 to this Regulation shall remain between -0.5 per cent and -2.5 per cent without manual adjustment. In the "unladen" state, with one person in the driver's seat, this vertical orientation shall be initially set between -1 per cent and -1.5 per cent. For each type of vehicle the manufacturer shall specify this initial orientation, which shall be shown on a plate on each vehicle.
- 6.2.5.2. If the foregoing condition is met by means of a device acting on the position of the headlight in relation to the vehicle, the beam shall not in the event of failure of the device assume a position in which the dip is less than it was at the time when the failure of the device occurred.
- 6.2.5.2.1. The conditions laid down in paragraph 6.2.5.2. above shall be met by automatic means.
- 6.2.5.2.2. Devices which are adjusted manually, either in continuous or in stepped fashion, may nevertheless be allowed provided they have a reference position whereby the headlamps can be put back to the initial vertical orientation specified in paragraph 6.2.5.1. by means of the usual adjusting screws. These manually adjustable devices must be operable from the driving seat.
- 6.2.5.2.2.1. Continuously adjustable devices must have reference marks indicating the main loading conditions.
- 6.2.5.2.2.2. The number of positions on stepped adjustable devices must be such that, starting from a vertical orientation value of between -1 per cent and -1.5 per cent, observance of the -0.5 per cent to -2.5 per cent range is ensured for all the states of loading defined in annex 5 to this Regulation. The states of loading corresponding to each position must be clearly indicated near the control.
- 6.2.6. May be "grouped" with the driving lamp and the other front lamps.
- 6.2.7. May not be "combined" with any other lamp.

6.2.8. May be "reciprocally incorporated"

6.2.8.1. with the driving lamp, unless the latter swivels according to the angle of lock of the steering;

6.2.8.2. with the other front lamps.

6.2.9. Electrical connections

The control for changing over to the passing lamp shall switch of all driving lamps simultaneously.

The passing lamps may remain switched on at the same time as the driving lamps.

6.2.10. Tell-tale

Optional.

6.2.11. Other requirements

The requirements of paragraph 5.5.2. shall not apply to passing lamps.

6.3. DIRECTION-INDICATOR LAMP

6.3.1. Number

According to the arrangement (see figure below).

6.3.2. Arrangement

A	(2 front indicators (category 1) (2 rear indicators (category 2) (2 repeating side indicators (category 5))
B	(2 rear indicators (category 2))

Arrangement A shall apply to all power-driven vehicles...

Arrangement B shall apply to trailers only.

6.3.3. Position

6.3.3.1. In width: the distance between the extreme outer edge of the vehicle and the outer edge of the illuminating surface shall not exceed 400 mm. The clearance between the inner edges of the two illuminating surfaces shall not be less than 600 mm.

Where the vertical distance between the rear direction-indicator lamp and the corresponding rear position (side) lamp is not more than 300 mm, the distance between the extreme outer edge of the vehicle and the outer edge of the rear direction-indicator lamp shall not exceed by more than 50 mm the distance between the extreme outer edge of the vehicle and the corresponding rear position (side) lamp.

6.3.3.2. In height: above the ground: not less than 500 mm for indicators of category 5; not less than 350 mm for categories 1 and 2; not more than 1,500 mm for all categories. If the structure of the vehicle makes it impossible to keep to this maximum figure, the highest point on the illuminating surface may be at 2,300 mm in the case of indicators of category 5 and 2,100 mm in the case of indicators of categories 1 and 2.

- 6.3.3.3. In length: the distance between the centre of reference of the illuminating surface of the side indicator (arrangement A) and the transverse plane which marks the forward boundary of the vehicle's over-all length shall not exceed 1,800 mm. If the structure of the vehicle makes it impossible to keep to the minimum angles of visibility, this distance may be increased to 2,500 mm if the vehicle is equipped in conformity with arrangement A.
- 6.3.3.4. The distance between the illuminating surface of a front direction indicator and the illuminating surface of a passing lamp or fog lamp shall not be less than 40 mm. A smaller distance shall be permitted, however, if the luminous intensity in the reference axis of the direction indicator is not less than 400 cd.
- 6.3.4. Geometric visibility  
Horizontal angles: see figure below.  
Vertical angles: 15° above and below the horizontal.  
The vertical angle below the horizontal may be reduced to 5°, in the case of side direction indicator lamps of arrangement A, if the height is less than 750 mm.
- 6.3.5. Orientation  
According to the specifications for installation by the manufacturer, if any.
- 6.3.6. May be "grouped" with one or more lamps.
- 6.3.7. May not be "combined" with any other lamp.
- 6.3.8. May not be "reciprocally incorporated" with any lamp other than the parking lamp.
- 6.3.9. Electrical connections  
Direction-indicator lamps shall switch on independently of the other lamps. All direction-indicator lamps on one side of a vehicle shall be switched on and off by means of one control and shall flash in phase.
- 6.3.10. "Operating" tell-tale  
Mandatory for all direction-indicator lamps not directly visible to the driver. It may be optical, auditory or both.  
If it is optical it shall be a flashing lamp which, in the event of defective operation of any of the direction indicators other than repeating side indicators, is extinguished, remains alight without flashing, or shows a marked change of frequency. If it is solely auditory it shall be clearly audible and show a marked change of frequency in like circumstances.

If a power-driven vehicle is equipped to draw a trailer, it shall be equipped with a special optical operational tell-tale for the direction indicator lamps on the trailer unless the tell-tale of the drawing vehicle allows the failure of any one of the direction indicator lamps on the vehicle combination thus formed to be detected.

6.3.11. Other requirements

Light flashing  $90 \pm 30$  times per minute.

Operation of the light-signal control shall be followed within not more than one second by the appearance of the light and within not more than one-and-one-half seconds by the first extinction of the light.

If a power-driven vehicle is equipped to draw a trailer, the direction-indicator-lamp control shall be capable of bringing the trailer's direction indicators into action also.

In the event of failure, other than a short-circuit, of one direction-indicator lamp, the others must continue to flash, but the frequency in this condition may be different from that prescribed.

6.4. STOP LAMP

6.4.1. Number

Two.

6.4.2. Arrangement

No special requirement.

6.4.3. Position

6.4.3.1. In width: not less than 600 mm apart. This distance may be reduced to 400 mm if the over-all width of the vehicle is less than 1,300 mm.

6.4.3.2. In height: above the ground, not less than 350 mm nor more than 1,500 mm (2,100 mm if the shape of the bodywork makes it impossible to keep within 1,500 mm).

6.4.3.3. In length: at the rear of the vehicle.

6.4.4. Geometric visibility

Horizontal angle:  $45^\circ$  outwards and inwards.

Vertical angle:  $15^\circ$  above and below the horizontal. The vertical angle below the horizontal may be reduced to  $5^\circ$ , however, if the height of the lamp is less than 750 mm.

Figure (see paragraph 6.3)

DIRECTION INDICATOR LAMP ANGLES  
OF GEOMETRIC VISIBILITY

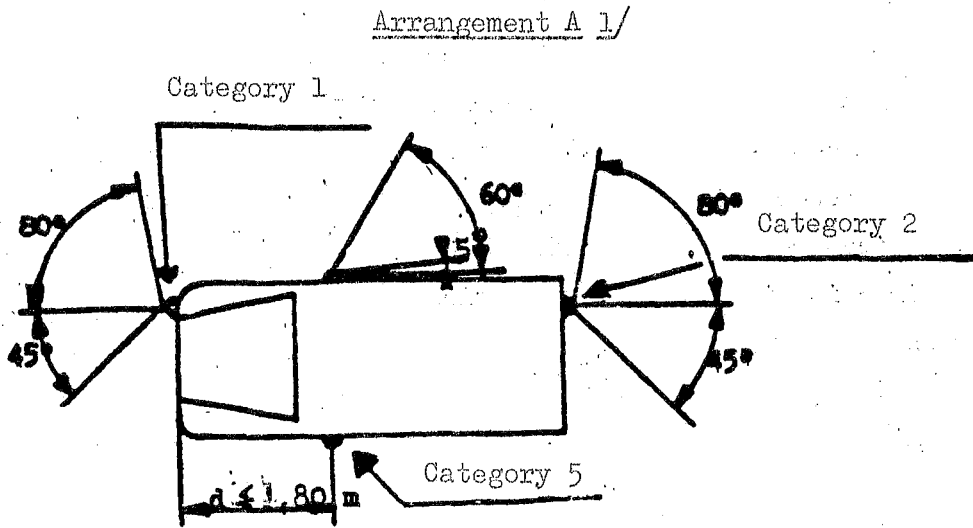

Arrangement B

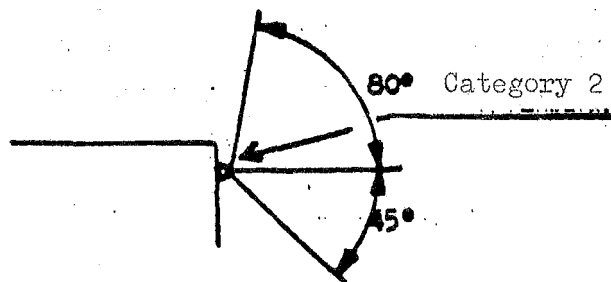

1/ The figure of 5° given as the angle of no visibility ("blind angle") rearwards of the side indicator is an upper limit.

- 6.4.5. Orientation  
Towards the rear of the vehicle.
- 6.4.6. May be "grouped" with one or more other rear lamps.
- 6.4.7. May not be "combined" with any other lamp.
- 6.4.8. May be "reciprocally incorporated" with the rear position (side) lamp or the parking lamp.
- 6.4.9. Electrical connections  
Shall light up when the service brake is applied.
- 6.4.10. "Operational" tell-tale  
Optional. The tell-tale, if provided, shall be a non-flashing signal lamp which lights up on the failure of a stop lamp.
- 6.4.11. Other requirements  
The luminous intensity of the stop lamps shall be markedly greater than that of the rear position (side) lamps.
- 6.5. REAR-REGISTRATION-PLATE ILLUMINATING DEVICE
- 6.5.1. Number  
Such that the device illuminates the site of the registration plate.
- 6.5.2. Arrangement  
Such that the device illuminates the site of the registration plate.
- 6.5.3. Position
- 6.5.3.1. In width: such that the device illuminates the site of the registration plate.
- 6.5.3.2. In height: such that the device illuminates the site of the registration plate.
- 6.5.3.3. In length: such that the device illuminates the site of the registration plate.
- 6.5.4. Geometric visibility  
Such that the device illuminates the site of the registration plate.
- 6.5.5. Orientation  
Such that the device illuminates the site of the registration plate.
- 6.5.6. May be "grouped" with one or more rear lamps.
- 6.5.7. May be "combined" with the rear position (side) lamps.

6.5.8. May not be "reciprocally incorporated" with any other lamp.

6.5.9. Electrical connections  
The device shall light up only at the same time as the rear position (side) lamps.

6.5.10. "Circuit-closed" tell-tale  
Optional. If it exists its function shall be performed by the tell-tale prescribed for the position (side) lamps.

6.6. FRONT POSITION (SIDE) LAMP

6.6.1. Number  
Two.

6.6.2. Arrangement  
No special requirement.

6.6.3. Position

6.6.3.1. In width: that point on the illuminating surface which is farthest from the vehicle's median longitudinal plane shall not be more than 400 mm from the extreme outer edge of the vehicle.

In the case of a trailer, that point on the illuminating surface which is farthest from the longitudinal plane of symmetry shall not be more than 150 mm from the extreme outer edge of the vehicle.

The clearance between the inner edges of the two illuminating surfaces shall not be less than 600 mm.

6.6.3.2. In height: above the ground, not less than 350 mm nor more than 1,500 mm (2,100 mm if the shape of the bodywork makes it impossible to keep within 1,500 mm).

6.6.3.3. In length: at the front of the vehicle.

6.6.4. Geometric visibility

Horizontal angle for the assembly formed by the two front position (side) lamps:

- either 45° inwards and 80° outwards,
- or 80° inwards and 45° outwards.

Vertical angle: 15° above and below the horizontal. The vertical angle below the horizontal may be reduced to 5°, however, if the height of the lamp is less than 750 mm.



- 6.6.5. Orientation  
Forwards.
- 6.6.6. May be "grouped" with any other front lamp.
- 6.6.7. May not be "combined" with any other lamp.
- 6.6.8. May be "reciprocally incorporated" with any other front lamp.
- 6.6.9. Electrical connections  
No special requirement.
- 6.6.10. Tell-tale  
Mandatory. This tell-tale shall be non-flashing and shall not be required if the instrument panel (dashboard) lighting can be switched on or off only simultaneously with the position (side) lamps.
- 6.6.11. Other requirements  
None.
- 6.7. REAR POSITION (SIDE) LAMP
- 6.7.1. Number  
Two.
- 6.7.2. Arrangement  
No special requirement.
- 6.7.3. Position
- 6.7.3.1. In width: that point on the illuminating surface which is farthest from the vehicle's median longitudinal plane shall not be more than 400 mm from the extreme outer edge of the vehicle. The clearance between the inner edges of the illuminating surfaces shall not be less than 600 mm. This distance may be reduced to 400 mm if the over-all width of the vehicle is less than 1,300 mm.
- 6.7.3.2. In height: above the ground, not less than 350 mm nor more than 1,500 mm (2,100 mm if the shape of the bodywork makes it impossible to keep within 1,500 mm).
- 6.7.3.3. In length: at the rear of the vehicle.
- 6.7.4. Geometric visibility  
Horizontal angle for the assembly formed by the two rear position (side) lamps:  
either 45° inwards and 80° outwards,  
or 80° inwards and 45° outwards.

Vertical angle: 15° above and below the horizontal. The vertical angle below the horizontal may be reduced to 5°, however, if the height of the lamp is less than 750 mm.

6.7.5. Orientation

Rearwards.

6.7.6. May be "grouped" with any other rear lamp.

6.7.7. May be "combined" with the rear-registration-plate illuminating device.

6.7.8. May be "reciprocally incorporated" with the stop lamps or the rear fog lamps or the parking lamp.

6.7.9. Electrical connections

No special requirement.

6.7.10. "Circuit-closed" tell-tale

Mandatory. Its function shall be performed by the tell-tale prescribed for the front position (side) lamps.

6.8. REAR REFLEX REFLECTOR, NON-TRIANGULAR

6.8.1. Number

Two.

6.8.2. Arrangement

No special requirement.

6.8.3. Position

6.8.3.1. In width: that point on the illuminating surface which is farthest from the vehicle's median longitudinal plane shall not be more than 400 mm from the extreme outer edge of the vehicle.

The inner edges of the reflex reflector shall not be less than 600 mm apart. This distance may be reduced to 400 mm if the over-all width of the vehicle is less than 1,300 mm.

6.8.3.2. In height: not less than 350 mm nor more than 900 mm above the ground.

6.8.3.3. In length: no specific requirement.

6.8.4. Geometric visibility

Horizontal angle: 30° inwards and outwards.

Vertical angle: 15° above and below the horizontal. The vertical angle below the horizontal may be reduced to 5°, however, if the height of the light is less than 750 mm.

6.8.5. Orientation

Rearwards.

6.8.6. May be "grouped" with any other lamp.

6.8.7. Other requirements

The illuminating surface of the reflex reflector may have parts in common with that of any other lamp situated at the rear.

6.9. REAR REFLEX REFLECTOR, TRIANGULAR

6.9.1. Number

Two.

6.9.2. Arrangement

The apex of the triangle shall be directed upwards.

6.9.3. Position

6.9.3.1. In width: that point on the illuminating surface which is farthest from the vehicle's median longitudinal plane shall not be more than 400 mm from the extreme outer edge of the vehicle.

The inner edges of the reflex reflectors shall not be less than 600 mm apart. This distance may be reduced to 400 mm if the over-all width of the vehicle is less than 1,300 mm.

6.9.3.2. In height: not less than 350 mm and not more than 900 mm above the ground.

6.9.3.3. In length: no specific requirement.

6.9.4. Geometric visibility

Horizontal angle: 30° inwards and outwards.

Vertical angle: 15° above and below the horizontal. The vertical angle below the horizontal may be reduced to 5°, however, if the height of the light is less than 750 mm.

6.9.5. Orientation

Rearwards.

6.9.6. May not be "grouped" with any other lamp.

6.9.7. Other requirements

No lamp shall be placed inside the triangle.

6.10. FRONT REFLEX REFLECTOR, NON-TRIANGULAR

6.10.1. Number

Two.

6.10.2. Arrangement

No special requirement.

6.10.3. Position

6.10.3.1. In width: that point on the illuminating surface which is farthest from the vehicle's median longitudinal plane shall not be more than 400 mm from the extreme outer edge of the vehicle.

In the case of a trailer, the point of the illuminating surface which is farthest from the vehicle's median longitudinal plane shall not be farther than 150 mm from the extreme outer edge of the vehicle.

The inner edges of the reflex reflectors shall not be less than 600 mm apart. This distance may be reduced to 400 mm if the over-all width of the vehicle is less than 1,300 mm.

6.10.3.2. In height: not less than 350 mm and not more than 900 mm above the ground or 1,500 mm if the structure of the vehicle makes it impossible to keep within 900 mm.

6.10.3.3. In length: no specific requirement.

6.10.4. Geometric visibility

Horizontal angle: 30° inwards and outwards.

Vertical angle: 15° above and below the horizontal. The vertical angle below the horizontal may be reduced to 5°, however, if the height of the lamp is less than 750 mm.

6.10.5. Orientation

Forwards.

6.10.6. May be "grouped" with the front position (side) lamps.

6.10.7. Other requirements

The illuminating surface of the reflex reflector may have parts in common with that of the front position (side) lamp.

6.11. SIDE REFLEX REFLECTOR, NON-TRIANGULAR

6.11.1. Minimum number per side

Such that the requirements for longitudinal positioning are complied with.

6.11.2. Arrangement

No special requirement.

6.11.3. Position

6.11.3.1. Width: no special requirement.

6.11.3.2. Height: above the ground, not less than 350 mm nor more than 900 mm (1,500 mm if the shape of the structure of the vehicle makes it impossible to keep within 900 mm).

- 6.11.3.3. Length: at least one reflex reflector shall be fitted to the middle third of the vehicle, the foremost reflex reflector being no further than 3 m from the front, and in the case of trailers, inclusive of the drawbar.
- The distance between two adjacent reflex reflectors shall not exceed 3 m. The distance between the rearmost reflex reflector and the rear of the vehicle shall not exceed 1 m.
- 6.11.4. Geometric visibility
- Horizontal angles,  $\beta$  : 45° to the front and to the rear.  
Vertical angles,  $\alpha$  : 15° above and below the horizontal.  
The vertical angle below the horizontal may be reduced to 5°, however, if the height of the reflector is less than 750 mm.
- 6.11.5. Orientation
- The reference axis of the reflex reflector shall be horizontal and perpendicular to the vehicle's median longitudinal plane and directed outwards.
- 6.11.6. May be "grouped" with other lamps.
- 6.12. HAZARD WARNING SIGNAL
- 6.12.1. The signal shall be given by simultaneous operation of the direction-indicator lights in accordance with the requirements of paragraph 6.3. above.
- 6.12.2. Electrical connections
- The signal shall be given by means of a separate control enabling all the direction indicators to function in phase.
- 6.12.3. "Circuit-closed" tell-tale
- Mandatory. Flashing signal lamp which may operate in conjunction with the tell-tale or tell-tales prescribed in paragraph 6.3.10.
- 6.12.4. Other requirements
- As specified in paragraph 6.3.11. If a power-driven vehicle is equipped to draw a trailer the hazard warning signal control shall also be capable of bringing the direction-indicator lamps on the trailer into action. The hazard warning signal shall be able to function even if the device which starts or stops the engine is in a position which makes it impossible to start the engine.

6.13. FRONT FOG LAMP

6.13.1. Number

Two.

6.13.2. Arrangement

No special requirement.

6.13.3. Position

6.13.3.1. In width: that point on the illuminating surface which is farthest from the vehicle's median longitudinal plane shall not be more than 400 mm from the extreme outer edge of the vehicle.

6.13.3.2. In height: not less than 250 mm above the ground. No point on the illuminating surface shall be higher than the highest point on the illuminating surface of the passing lamp.

6.13.3.3. In length: at the front of the vehicle. This requirement shall be deemed to be satisfied if the light emitted does not cause discomfort to the driver either directly, or indirectly through the rear-view mirrors and/or other reflecting surfaces of the vehicle.

6.13.4. Geometric visibility

Defined by angles and as specified in paragraph 2.11:

= 5° upwards and downwards;

= 45° outwards and 10° inwards.

6.13.5. Orientation

Forwards.

The orientation of the fog lamps shall not vary according to the angle of lock of the steering. They shall not cause undue dazzle or discomfort to oncoming drivers or other road users.

6.13.6. May be "grouped" with the other front lamps.

6.13.7. May not be "combined" with any other front lamp.

6.13.8. May be "reciprocally incorporated" with the driving lamps, unless the latter swivel according to the angle of lock of the steering when there are four headlamps, with the front position (side) lamps and with the parking lamp.

6.13.9. Electrical connections

It shall be possible to switch the fog lamps on or off independently of the driving lamps and passing lamps and vice versa.

6.13.10. "Circuit-closed" tell-tale

Optional.

6.14. REAR FOG LAMP

6.14.1. Number

One or two.

6.14.2. Arrangement

No special requirement.

6.14.3 Position

6.14.3.1. In width: when there is only one rear fog lamp its position in relation to the median longitudinal plane of the vehicle shall be on the side of the vehicle opposite to the prescribed direction of traffic in the country of registration.

6.14.3.2. In height: not less than 250 mm nor more than 1,000 mm above the ground.

6.14.3.3. In length: at the rear of the vehicle.

6.14.3.4. In all cases (single lamp or two lamps), the distance between the illuminating surface of the rear fog lamp and that of the stop lamp shall be not less than 100 mm.

6.14.4. Geometric visibility

Defined by angles  $\alpha$  and  $\beta$  as specified in paragraph 2.11:

$\alpha = 5^\circ$  upwards and  $5^\circ$  downwards;

$\beta = 25^\circ$  to right and to left.

6.14.5. Orientation

Rearwards.

6.14.6. May be "grouped" with any other rear lamp.

6.14.7. May not be "combined" with any other lamp.

6.14.8. May be "reciprocally incorporated" with the rear position (side) lamps or the parking lamp.

6.14.9. Electrical connections

Such that it can light up only when one or more of the following lamps are switched on: passing lamps or front fog lamps.

If there are front fog lamps, it shall be possible to switch off the rear fog lamp independently of the front fog lamps.

6.14.10. "Circuit-closed" tell-tale

Mandatory. An independent, fixed-intensity warning lamp.

6.15. REVERSING LAMP

6.15.1. Number

One or two.

6.15.2. Arrangement

No special requirement.

6.15.3. Position

6.15.3.1. In width: no special requirement.

6.15.3.2. In height: not less than 250 mm nor more than 1,200 mm above the ground.

6.15.3.3. In length: at the back of the vehicle.

6.15.4. Geometric visibility

Defined by angles  $\alpha$  and  $\beta$  as specified in paragraph 2.11:

$\alpha = 15^\circ$  upwards and  $5^\circ$  downwards;

$\beta = 45^\circ$  to right and to left if there is only one light,  
 $45^\circ$  outwards and  $30^\circ$  inwards if there are two.

6.15.5. Orientation

Rearwards.

6.15.6. May be "grouped" with any other rear lamp.

6.15.7. May not be "combined" with any other lamp.

6.15.8. May not be "reciprocally incorporated" with any other lamp.

6.15.9. Electrical connections

They shall be such that the lamp can light up only if the reverse gear is engaged and if the device which controls the starting and stopping of the engine is in such a position that operation of the engine is possible. It shall not light up or remain lit if either of the above conditions is not satisfied.

6.15.10. Tell-tale

Optional.

6.15.11. Other requirements

None.

6.16. PARKING LAMP

6.16.1. Number

According to the arrangement.

6.16.2. Arrangement

Either two lamps at the front and two lamps at the rear, or one lamp on each side.

6.16.3. Position

6.16.3.1. In width: that point on the illuminating surface which is farthest from the vehicle's median longitudinal plane shall not be more than 400 mm from the extreme outer edge of the vehicle.

Furthermore, if there are two lamps, they shall be on the sides of the vehicle.



- 6.16.3.2. In height: above the ground, not less than 350 mm nor more than 1,500 mm (2,100 mm if the shape of the vehicle bodywork makes it impossible to keep within 1,500 mm).
- 6.16.3.3. In length: no special requirement.
- 6.16.4. Geometric visibility  
Horizontal angle:  $45^{\circ}$  outwards, forwards and rearwards.  
Vertical angle:  $15^{\circ}$  above and below the horizontal. The vertical angle below the horizontal may be reduced to  $5^{\circ}$ , however, if the height of the lamp is less than 750 mm.
- 6.16.5. Orientation  
Such that the lamps meet the requirements for visibility forwards and rearwards.
- 6.16.6. May be "grouped" with any other lamp.
- 6.16.7. May not be "combined" with any other lamp.
- 6.16.8. May be "reciprocally incorporated".
- 6.16.8.1. At the front, with the front position (side) lamps, passing lamps, driving lamps and front fog lamps.
- 6.16.8.2. At the rear, with the rear position (side) lamps, stop lamps or rear fog lamps.
- 6.16.8.3. With direction indicators of category 5 (see paragraph 6.3).
- 6.16.9. Electrical connections  
It shall be possible to switch on the parking lamp or lamps on one side of the vehicle without switching on any other lamp.
- 6.16.10. Tell-tale  
Optional. If there is one, it shall not be possible to confuse it with the tell-tale for the front and rear position (side) lamps.
- 6.16.11. Other requirements  
The functioning of this lamp may also be performed by simultaneously switching on the front and rear position (side) lamps on the same side of the vehicle.
- 6.17. END-OUTLINE MARKER LAMP
- 6.17.1. Number  
Two visible from the front and two visible from the rear.
- 6.17.2. Arrangement  
No special requirement.
- 6.17.3. Position
- 6.17.3.1. In width: as close as possible to the extreme outer edge of the vehicle.

- 6.17.3.2. In height: at the greatest height compatible with the required position in width and symmetry of the lights.
- 6.17.3.3. In length: no special requirement.
- 6.17.4. Geometric visibility  
Horizontal angle:  $80^{\circ}$  outwards,  
Vertical angle:  $5^{\circ}$  above and  $20^{\circ}$  below the horizontal.
- 6.17.5. Orientation  
Such that the lamps meet the requirements for visibility forwards and rearwards.
- 6.17.6. May not be "grouped" with any other lamp.
- 6.17.7. May not be "combined" with any other lamp.
- 6.17.8. May not be "reciprocally incorporated" with any other lamp.
- 6.17.9. Electrical connections  
No special requirement.
- 6.17.10. Tell-tale  
Optional.
- 6.17.11. Other requirements  
Where the shape of the bodywork or equipment of the vehicle makes it impossible to meet the requirements of paragraph 6.17.3. above, and provided that all other requirements are met, the light visible from the front and the light visible from the rear on the same side of the vehicle may be combined in one device.  
The position of an end-outline marker lamp in relation to the corresponding position (side) lamp shall be such that the distance between the projections on a transverse vertical plane of the points nearest to one another on the illuminating surfaces of the two lamps considered is not less than 200 mm.
7. MODIFICATIONS OF THE VEHICLE TYPE OR OF THE INSTALLATION OF ITS LIGHTING AND LIGHT-SIGNALLING DEVICES
- 7.1. Every modification of the vehicle type, or of the installation of its lighting or light-signalting devices, or of the list referred to in paragraph 3.2.2. above, shall be notified to the administrative department which approved that vehicle type. The department may then either:
- 7.1.1. Consider that the modifications made are unlikely to have an appreciable adverse effect and that in any case the vehicle still meets the requirements; or
- 7.1.2. Require a further test report from the technical service responsible for conducting the tests.

- 7.2. Confirmation or refusal of approval, specifying the alteration, shall be communicated by the procedure specified in paragraph 4.3 above to the Parties to the Agreement applying this Regulation.
8. CONFORMITY OF PRODUCTION
- 8.1. Every vehicle bearing an approval mark as prescribed under this Regulation shall conform, as regards the installation of lighting and light-signalling devices and their characteristics, to the vehicle type approved.
- 8.2. In order to verify conformity as prescribed in paragraph 8.1. above, a sufficient number of random checks shall be made on serially manufactured vehicles bearing the approval mark required by this Regulation.
9. PENALTIES FOR NON-CONFORMITY OF PRODUCTION
- 9.1. The approval granted in respect of a vehicle type pursuant to this Regulation may be withdrawn if the requirements laid down in paragraph 8.1 above are not complied with or if the vehicle or vehicles taken have failed to pass the tests prescribed in paragraph 8. above.
- 9.2. If a Party to the Agreement applying this Regulation withdraws an approval it has previously granted, it shall forthwith so notify the other Contracting Parties applying this Regulation, by means of a copy of the approval form bearing at the end, in large letters, the signed and dated annotation "APPROVAL WITHDRAWN".
10. PRODUCTION DEFINITELY DISCONTINUED
- If the holder of the approval completely ceases to manufacture a type of vehicle approved in accordance with this Regulation he shall so inform the authority which granted the approval. Upon receiving the relevant communication that authority shall inform thereof the other Parties to the Agreement which apply this Regulation by means of a copy of the approval form bearing at the end, in large letters, the signed and dated annotation "PRODUCTION DISCONTINUED".
11. NAMES AND ADDRESSES OF THE TECHNICAL SERVICES RESPONSIBLE FOR CONDUCTING APPROVAL TESTS, AND OF ADMINISTRATIVE DEPARTMENTS
- The Parties to the Agreement applying this Regulation shall communicate to the United Nations Secretariat the names and addresses of the technical services responsible for conducting approval tests and of the administrative departments which grant approval and to which forms certifying approval or refusal or withdrawal of approval, issued in other countries, are to be sent.

Annex 1

(Maximum format: A 4 (210 x 297 mm))

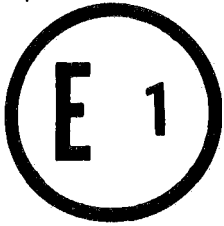

Name of administration

Communication concerning the approval (or refusal or withdrawal of approval or production definitely discontinued) of a vehicle type with regard to the installation of lighting and light-signalling devices, pursuant to Regulation No. 48

Approval No. ....

1. Trade name or mark of vehicle .....

2. Vehicle type .....

3. Manufacturer's name and address .....

4. If applicable, name and address of manufacturer's representative .....

5. Lighting devices present on the vehicle submitted for approval <sup>1/</sup> <sup>2/</sup> .....

5.1. Driving lamps: yes/no\*

5.2. Passing lamps: yes/no\*

5.3. Direction-indicator lamps: yes/no\*

5.4. Stop lamps: yes/no\*

5.5. Rear-registration-plate illuminating device: yes/no\*

\* / Strike out what does not apply.

<sup>1/</sup> Show for each device, on a separate form (list prescribed in paragraph 3.2.2. of this Regulation), the types of devices, duly identified, meeting the installation requirements of this Regulation.

<sup>2/</sup> Attach diagrams of the vehicle as indicated in paragraph 4.3. of this Regulation.

- 5.6. Front position (side) lamps: yes/no<sup>\*/</sup>
- 5.7. Rear position (side) lamps: yes/no<sup>\*/</sup>
- 5.8. Rear reflex reflectors, non-triangular: yes/no<sup>\*/</sup>
- 5.9. Rear reflex reflectors, triangular: yes/no<sup>\*/</sup>
- 5.10. Front reflex reflectors, non-triangular: yes/no<sup>\*/</sup>
- 5.11. Side reflex reflectors, non-triangular: yes/no<sup>\*/</sup>
- 5.12. Hazard warning signal: yes/no<sup>\*/</sup>
- 5.13. Front fog lamps: yes/no<sup>\*/</sup>
- 5.14. Rear fog lamps: yes/no<sup>\*/</sup>
- 5.15. Reversing lamps: yes/no<sup>\*/</sup>
- 5.16. Parking lamps: yes/no<sup>\*/</sup>
- 5.17. End-outline marker lamps: yes/no<sup>\*/</sup>
- 6. Equivalent lamps: .....
- 7. Vehicle submitted for approval on .....
- 8. Technical service responsible for conducting approval tests .....
- 9. Date of report issued by that service .....
- 10. Number of report issued by that service .....
- 11. Approval granted/refused<sup>\*/</sup>
- 12. Position of approval mark on vehicle .....
- 13. Place .....
- 14. Date .....
- 15. Signature .....

---

<sup>\*/</sup> Strike out what does not apply.

Annex 2

ARRANGEMENTS OF APPROVAL MARKS

Model A

(See paragraph 4.4. of this Regulation)

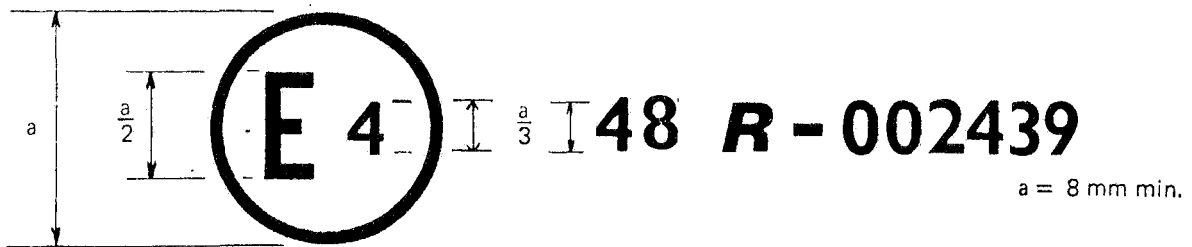

The above approval mark affixed to a vehicle shows that the vehicle type concerned has, with regard to the installation of lighting and light-signalling devices, been approved in the Netherlands (E4) pursuant to Regulation No. 48. The approval number indicates that the approval was granted in accordance with the requirements of Regulation No. 48 in its original form.

Model B

(See paragraph 4.5. of this Regulation)

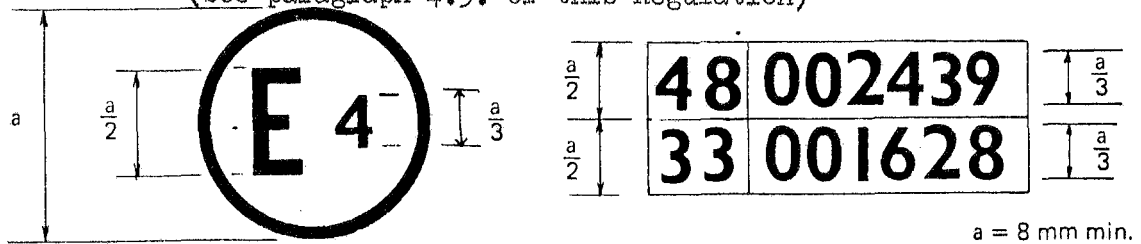

The above approval mark affixed to a vehicle shows that the vehicle type concerned has been approved in the Netherlands (E4) pursuant to Regulation No. 48 and Regulation No. 33 <sup>1/</sup>. The approval numbers indicate that, at the dates when the respective approvals were given, Regulations No. 48 and No. 33 were still in their original form.

<sup>1/</sup> The second number is given merely as an example.

Annex 3

DEFINITION OF THE ILLUMINATING SURFACE

(See paragraph 2.7. of this Regulation)

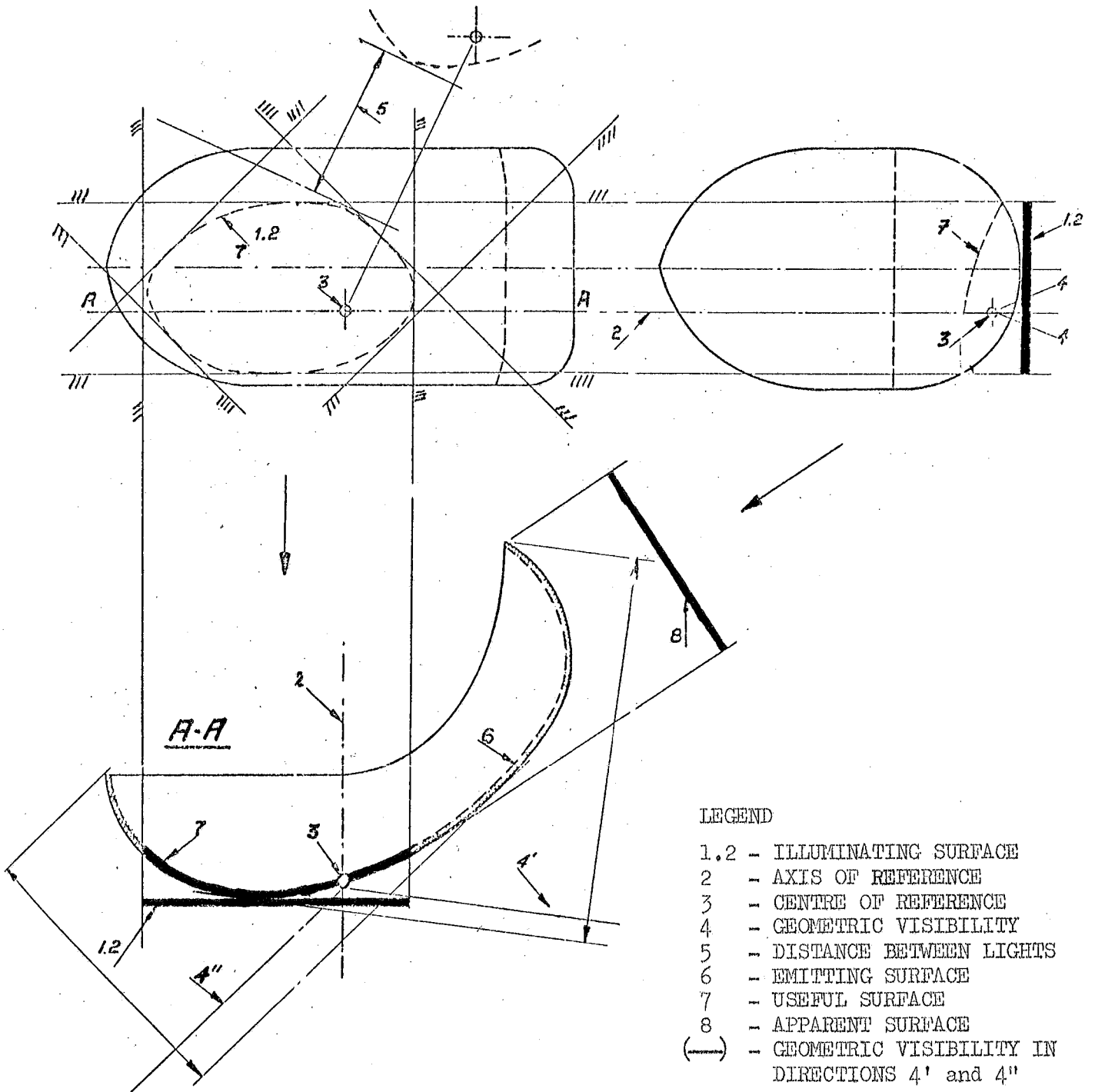

LEGEND

- 1.2 - ILLUMINATING SURFACE
- 2 - AXIS OF REFERENCE
- 3 - CENTRE OF REFERENCE
- 4 - GEOMETRIC VISIBILITY
- 5 - DISTANCE BETWEEN LIGHTS
- 6 - EMITTING SURFACE
- 7 - USEFUL SURFACE
- 8 - APPARENT SURFACE
- (—) - GEOMETRIC VISIBILITY IN DIRECTIONS 4' and 4''

Annex 4

FORWARD VISIBILITY OF RED LIGHTS AND  
REARWARD VISIBILITY OF WHITE LIGHTS

(See paragraph 5.10. of this Regulation)

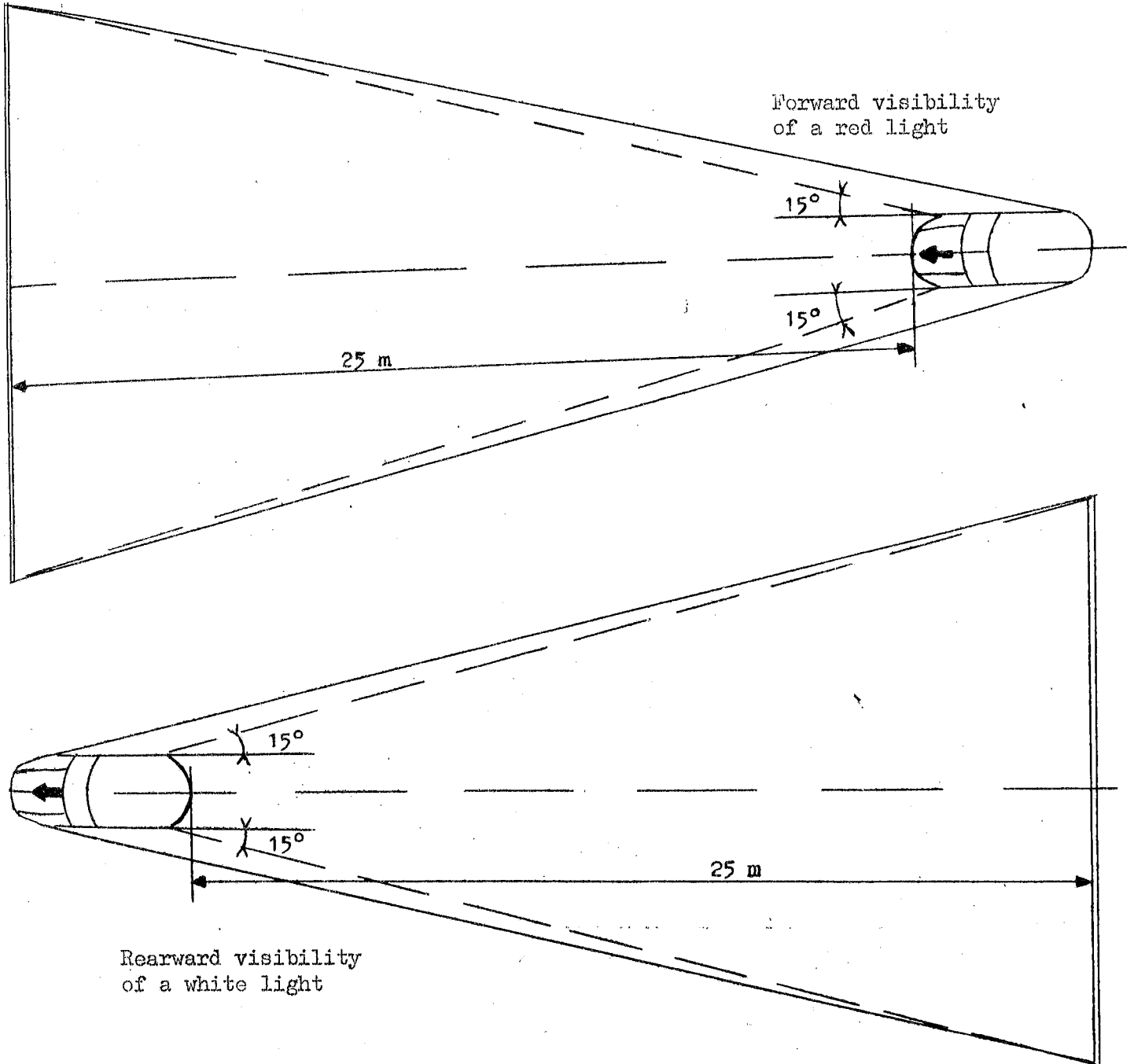



Annex 5

STATES OF LOADING TO BE TAKEN INTO CONSIDERATION IN DETERMINING  
VARIATIONS IN THE VERTICAL ORIENTATION OF THE PASSING BEAM

(See paragraph 6.2.5. of the Regulation)

1. For the purpose of establishing the states of loading specified below, the weight of an occupant shall be assumed to be 75 kg.
2. States of loading for the different types of vehicles:
  - 2.1. Vehicles of category M<sub>1</sub><sup>1/</sup>
    - 2.1.1. one person in the driver's seat;
    - 2.1.2. one person in the driver's seat and one in the front seat farthest from the driver;
    - 2.1.3. one person in the driver's seat, one in the front seat farthest from the driver, and all the seats farthest to the rear occupied;
    - 2.1.4. all seats occupied;
    - 2.1.5. all seats occupied, plus a balanced load in the luggage boot, so as to attain the permissible load on the rear axle, or on the front axle if the luggage boot is at the front. If the vehicle has a boot at the front and a boot at the rear, the additional load shall be uniformly distributed so as to attain the permissible loads on the axles. If the authorized total weight is exceeded, however, the load in the boot or boots shall be so limited as to attain the authorized weight without exceeding it;
    - 2.1.6. one person in the driver's seat, plus a balanced load in the luggage boot or boots, so as to attain each time the permissible load on the corresponding axle. However, if the maximum permissible laden weight is obtained before the permissible load on the axle, the loading of the boot(s) shall be limited to the figure which enables that weight to be reached.
    - 2.1.7. In determining the above loads, account shall be taken of any restrictions on the loading conditions which the manufacturer may have specified in the information sheet.
  - 2.2. Vehicles of categories N<sub>1</sub>, N<sub>2</sub> and N<sub>3</sub>
    - 2.2.1. Vehicles having a loading surface
      - 2.2.1.1. vehicle unladen;

---

<sup>1/</sup> For definitions of the categories, see Regulation No. 13 annexed to the 1958 Agreement.

- 2.2.1.2. one person in the driver's seat, the load being so distributed as to attain the maximum technically permissible load on the rear axle or axles and a load on the front axle corresponding as closely as possible to that of the unladen vehicle. If the loading surface is at the front of the vehicle the procedure shall be, mutatis mutandis, the same.
- 2.2.2. Vehicles not having a loading surface
- 2.2.2.1. Drawing vehicles for semi-trailers
- 2.2.2.1.1. unladen vehicle without a load on the coupling attachment;
- 2.2.2.1.2. one person in the driver's seat and the technically permissible load on the fifth wheel, the latter being in the position corresponding to the maximum load on the rear axle.
- 2.2.2.2. Drawing vehicles for trailers
- 2.2.2.2.1. vehicle unladen;
- 2.2.2.2.2. one person in the driver's seat, all the other seats provided in the cab being occupied.
- 2.3. Vehicles of categories M<sub>2</sub> and M<sub>3</sub>
- 2.3.1. vehicle unladen;
- 2.3.2. the vehicle loaded in such a way that each of the axles bears its technically permissible load.
-