



Economic and Social Council

Distr.: General
4 August 2010

Original: English

Economic Commission for Europe

Inland Transport Committee

World Forum for Harmonization of Vehicle Regulations

One-hundred-and-fifty-second session

Geneva, 9–12 November 2010

Item 4.4.1 of the provisional agenda

1958 Agreement – Consideration of draft amendments to existing Regulations proposed by GRSP

Proposal for the 04 series of amendments to Regulation No. 12 (Steering mechanism)

Submitted by the Working Party on Passive Safety *

The text reproduced below was adopted by the Working Party on Passive Safety (GRSP) at its forty-seventh session. It is based on ECE/TRANS/WP.29/GRSP/2010/19, as amended by Annex III to the report (ECE/TRANS/WP.29/GRSP/47, para.16). It is submitted to the World Forum for Harmonization of Vehicle Regulations (WP.29) and to the Administrative Committee (AC.1) for consideration.

* In accordance with the programme of work of the Inland Transport Committee for 2006–2010 (ECE/TRANS/166/Add.1, programme activity 02.4), the World Forum will develop, harmonize and update Regulations in order to enhance the performance of vehicles. The present document is submitted in conformity with that mandate.

The table of contents,

Insert a reference to a new Annex 7 and its Appendix 1, to read:

“ ...

Annex 7 - Test Procedures for the protection of the occupants of vehicles operating on electrical power from high voltage and electrolyte spillage.

Appendix 1 – Jointed Test Finger (IPXXB)”

The text of the Regulation,

Paragraphs 1. and 1.1., amend to read

“1. Scope

1.1. This Regulation applies to the behaviour of the steering mechanism and to the electrical power train operating on high voltage as well as the high voltage components and systems which are galvanically connected to the high voltage bus of the electric power train, of motor vehicles of category M₁, and vehicles of category N₁ with a maximum permissible mass less than 1,500 kg, with regard to the protection of the occupants in a frontal collision.

Paragraph 2.2.2.1., amend to read:

“2.2.2.1. The structure, dimensions, lines and constituent materials of that part of the vehicle forward of the steering control.”

Insert a new paragraph 2.2.2.2., to read:

“2.2.2.2. The locations of the RESS, in so far as they have a negative effect on the result of the impact test prescribed in this Regulation,”

Paragraph 2.2.2.2. (former), renumber as paragraph 2.2.2.3.

Paragraph 2.16., amend to read:

“2.16. Passenger compartment”

Insert new paragraphs 2.16.1. to 2.16.2., to read:

“2.16.1. “*Passenger compartment with regard to occupant protection*” means the space for occupant accommodation, bounded by the roof, floor, side walls, doors, outside glazing and front bulkhead and the plane of the rear compartment bulkhead or the plane of the rear-seat back support.

2.16.2. “*Passenger compartment for electric safety assessment*” means the space for occupant accommodation, bounded by the roof, floor, side walls, doors, outside glazing, front bulkhead and rear bulkhead, or rear gate, as well as by the electrical protection barriers and enclosures provided for protecting the power train from direct contact with high voltage live parts.”

Paragraph 2.18., amend to read:

“2.18. “*Mass of the vehicle in running order*” means the mass of the vehicle unoccupied and unladen but complete with fuel, coolant, lubricant tools and spare wheel, if provided as standard equipment by the vehicle manufacturer, and RESS.”

Paragraphs 2.19. to 2.21. shall be deleted.

Insert new paragraphs 2.19. to 2.38., to read:

- 2.19. “*High Voltage*” means the classification of an electric component or circuit, if its - working voltage is > 60 V and ≤ 1500 V direct current (DC) or > 30 V and $\leq 1,000$ V alternating current (AC) root – mean- square (rms),
- 2.20. “*Rechargeable energy storage system (RESS)*” means rechargeable energy storage system which provides electrical energy for propulsion,
- 2.21. “*Electrical Protection Barrier*” the part providing protection against any direct contact to the high voltage live parts,
- 2.22. “*Electrical power train*” means the electrical circuit which includes the traction motor(s), and may also include the RESS, the electrical energy conversion system, the electronic converters, the associated wiring harness and connectors, and the coupling system for charging the RESS,
- 2.23. “*Live parts*” means conductive part(s) intended to be electrically energized in normal use,
- 2.24. “*Exposed conductive part*” means the conductive part which can be touched under the provisions of the protection IPXXB, and which becomes electrically energized under isolation failure conditions,
- 2.25. “*Direct contact*” means the contact of persons with high voltage live parts,
- 2.26. “*Indirect contact*” means the contact of persons with exposed conductive parts,
- 2.27. “*Protection IPXXB*” means protection from contact with high voltage live parts provided by either an electrical protection barrier or an enclosure and tested using a Jointed Test Finger (IPXXB) as described in paragraph 4. of Annex 7.
- 2.28. “*Working voltage*” means the highest value of an electrical circuit voltage root-mean-square (rms), specified by the manufacturer, which may occur between any conductive parts in open circuit conditions or under normal operating conditions. If the electrical circuit is divided by galvanic isolation, the working voltage is defined for each divided circuit, respectively,
- 2.29. “*Coupling system for charging the rechargeable energy storage system (RESS)*” means the electrical circuit used for charging the RESS from an external electrical power supply including the vehicle inlet,
- 2.30. “*Electrical chassis*” means a set made of conductive parts electrically linked together, whose electrical potential is taken as reference,
- 2.31. “*Electrical circuit*” means an assembly of connected high voltage live parts which is designed to be electrically energized in normal operation,
- 2.32. “*Electric Energy conversion system*” means a system that generates and provides electrical energy for electrical propulsion,
- 2.33. “*Electronic converter*” means a device capable of controlling and/or converting electrical power for electrical propulsion,
- 2.34. “*Enclosure*” means the part enclosing the internal units and providing protection against any direct contact,
- 2.35. “*High Voltage Bus*” means the electrical circuit, including the coupling system for charging the RESS that operates on a high voltage,

- 2.36. “*Solid insulator*” means the insulating coating of wiring harnesses provided in order to cover and prevent the high voltage live parts from any direct contact. This includes covers for insulating the high voltage live parts of connectors; and varnish or paint for the purpose of insulation,
- 2.37. “*Automatic disconnect*” means a device that when triggered, galvanically separates the electrical energy sources from the rest of the high voltage circuit of the electrical power train,
- 2.38 “*Open type traction battery*” means a type of battery requiring liquid and generating hydrogen gas released to the atmosphere.”

Paragraphs 3.1.2.6. and 3.1.2.7., amend to read:

- “3.1.2.6. evidence that the steering mechanism complies with the specifications of paragraph 5.2.2. of Regulation No. 94 if the application for approval is submitted by the applicant pursuant paragraph 5.1.2. below.
- 3.1.2.7. evidence that the steering control complies with the specifications of paragraphs 5.2.1.4. and 5.2.1.5. of Regulation No. 94 if the application for approval is submitted by the applicant pursuant paragraph 5.2.1. below.”

Insert a new paragraph 3.1.2.8., to read:

- “3.1.2.8. A general description of the electric power source type, location and the electrical power train (e.g. hybrid, electric)”

Paragraph 3.2.2.3., amend to read:

- “3.2.2.3. evidence that the steering control complies with the specifications of paragraphs 5.2.1.4. and 5.2.1.5. of Regulation No. 94, if the application for approval is submitted by the applicant pursuant paragraph 5.2.1. below.”

Paragraph 4.2.2., amend to read:

- “4.2.2. An approval number shall be assigned to each type approved. Its first two digits (at present 04 corresponding to the 04 series of amendments) shall indicate the series of amendments incorporating the most recent major technical amendments made to the Regulation at the time of issue of the approval. The same Contracting Party shall not assign the same number to the same vehicle type equipped with another type of steering mechanism, or to another vehicle type, as defined in paragraph 2.2. above.”

Paragraph 4.3.2., amend to read:

- “4.3.2. An approval number shall be assigned to each type approved. Its first two digits (at present 04 corresponding to the 04 series of amendments) shall indicate the series of amendments incorporating the most recent major technical amendments made to the Regulation at the time of issue of the approval. The same Contracting Party shall not assign the same number to another steering control type as defined in paragraph 2.4. above.”

Paragraph 4.3.4.3., amend to read:

- “4.3.4.3. the symbol R94-02 in the case of an approval pursuant paragraph 5.2.1. below.”

Paragraph 5.1.1., amend to read:

- “5.1.1. Additionally vehicles equipped with electrical power train shall meet paragraph 5.5. This could be demonstrated in a separate frontal impact test at the request of the manufacturer after validation by the Technical Service, given that the electric components do not influence the driver's protection performance of the vehicle type as defined in this Regulation.”

Paragraphs 5.1.1.1. and 5.1.1.2., shall be deleted.

Paragraph 5.1.2., amend to read:

- “5.1.2. Specifications of paragraph 5.1. above are deemed to be met if the vehicle equipped with such a steering system complies with the specifications of paragraph 5.2.2. of Regulation No. 94.”

Paragraph 5.2.1., to read:

- “5.2.1. If the steering control is fitted with a steering wheel airbag, specifications of paragraph 5.2. above are deemed to be met if the vehicle equipped with such a steering system complies with the specifications of paragraphs 5.2.1.4. and 5.2.1.5. of Regulation No. 94.”

Insert new paragraphs 5.5. to 5.6., to read:

- “5.5. Following the test conducted in accordance with the procedure defined in Annex 3 to this Regulation the electrical power train operating on high voltage and the high voltage components and systems which are galvanically connected to the high voltage bus of the electrical power train shall meet the following requirements:

5.5.1. Protection against electrical shock

After the impact at least one of the four criteria specified in paragraphs 5.5.1.1. to 5.5.1.4.2. shall be met.

If the vehicle has an automatic disconnect function or device(s) that galvanically divide the electrical power train circuit during driving condition, at least one of the following criteria shall apply to the disconnected circuit or to each divided circuit individually after the disconnect function is activated.

However criteria defined in 5.5.1.4. shall not apply if more than a single potential of a part of the high voltage bus is not protected under the conditions of protection IPXXB.

In the case that the test is performed under the condition that part(s) of the high voltage system are not energized, the protection against electrical shock shall be proved by either paragraph 5.5.1.3. or paragraph 5.5.1.4. for the relevant part(s).

5.5.1.1. Absence of high voltage

The voltages V_b , V_1 and V_2 of the high voltage buses shall be equal or less than 30 VAC or 60 VDC as specified in paragraph 2. of Annex 7.

5.5.1.2. Low electrical energy

The total energy (TE) on the high voltage buses shall be less than 2.0 joules when measured according to the test procedure as specified in paragraph 3. formula (a) of Annex 7. Alternatively the total energy (TE) may be calculated by the measured voltage V_b of the high voltage bus and the capacitance of the

X-capacitors (C_x) specified by the manufacturer in paragraph 3. formula (b) of Annex 7.

The energy stored in the Y-capacitors (TE_{y1} , TE_{y2}) shall also be less than 2.0 joules. This shall be calculated by measuring the voltages V_1 and V_2 of the high voltage buses and the electrical chassis, and the capacitance of the Y-capacitors specified by the manufacturer according to formula (c) in paragraph 3. of Annex 7.

5.5.1.3. Physical protection

For protection against direct contact with high voltage live parts, the protection IPXXB shall be provided.

In addition, for protection against electrical shock which could arise from indirect contact, the resistance between all exposed conductive parts and the electrical chassis shall be lower than 0.1 ohm when there is current flow of at least 0.2 amperes.

This requirement is satisfied if the galvanic connection has been made by welding.

5.5.1.4. Isolation resistance

The criteria specified in the paragraphs 5.5.1.4.1. and 5.5.1.4.2. below shall be met.

The measurement shall be conducted in accordance with paragraph 5. of Annex 7.

5.5.1.4.1. Electrical power train consisting of separate DC- or AC-buses

If the AC high voltage buses and the DC high voltage buses are galvanically isolated from each other, isolation resistance between the high voltage bus and the electrical chassis (R_i as defined in paragraph 5. of Annex 7) shall have a minimum value of 100 Ω /volt of the working voltage for DC buses, and a minimum value of 500 Ω /volt of the working voltage for AC buses.

5.5.1.4.2. Electrical power train consisting of combined DC- and AC-buses

If the AC high voltage buses and the DC high voltage buses are galvanically connected isolation resistance between the high voltage bus and the electrical chassis (R_i as defined in paragraph 5. of Annex 7) shall have a minimum value of 500 Ω /volt of the working voltage.

However, if the protection IPXXB is satisfied for all AC high voltage buses or the AC voltage is equal or less than 30 V after the vehicle impact, the isolation resistance between the high voltage bus and the electrical chassis (R_i as defined in paragraph 5. of Annex 7) shall have a minimum value of 100 Ω /volt of the working voltage.

5.5.2. Electrolyte spillage

In the period from the impact until 30 minutes after, no electrolyte from the RESS shall spill into the passenger compartment, and no more than 7 per cent of electrolyte shall spill from the RESS except open type traction batteries outside the passenger compartment. For open type traction batteries no more than 7 per cent with a maximum of 5.0 liters shall spill outside the passenger compartment. The manufacturer shall demonstrate compliance in accordance with paragraph 6. of Annex 7.

5.5.3. RESS retention

RESS located inside the passenger compartment shall remain in the location in which they are installed and RESS components shall remain inside RESS boundaries.

No part of any RESS that is located outside the passenger compartment for electrical safety assessment shall enter the passenger compartment during or after the impact test.

The manufacture shall demonstrate compliance in accordance with paragraph 7. of Annex 7.

- 5.6. Specifications of paragraphs 5.5. to 5.5.3. above are deemed to be met if the vehicle equipped with an electric power train operating on high voltage complies with the specifications of paragraphs 5.2.8. to 5.2.8.3. of Regulation No. 94, 02 series of amendments.”

Paragraph 6.1., amend to read:

- “6.1. Compliance with the requirements of paragraphs 5.1. to 5.4. above shall be checked in accordance with the methods set out in Annexes 3, 4 and 5 to this Regulation. Compliance with the requirements of paragraph 5.5. above shall be checked in accordance with the methods set out in Annex 3 to this Regulation. All measurements should be done on the basis of ISO 6487 987.”

Paragraphs 13.1. to 13.3.1., amend to read:

- “13.1. As from the date of entry into force of the 04 series of amendments, Contracting Parties applying this Regulation shall grant approvals only if the vehicle type to be approved meets the requirements of this Regulation as amended by the 03 or the 04 series of amendments.

13.2. Approval of a vehicle type

- 13.2.1. As from the official date of entry into force of the 04 series of amendments, no Contracting Party applying this Regulation shall refuse to grant ECE approval under this Regulation as amended by the 04 series of amendments.

- 13.2.2. As from [24] months after the entry into force, Contracting Parties applying this Regulation shall grant ECE approvals only to those types of vehicle which comply with the requirements of this Regulation as amended by the 04 series of amendments.

- 13.2.3. Notwithstanding the above, Contracting Parties applying this Regulation may [continue to] grant ECE approvals to the 03 series of amendments for an additional [12] months provided that the manufacturer demonstrates, to the satisfaction of the Technical Service, that the vehicle provides equivalent levels of safety to those required by this Regulation as amended by the 04 series of amendments.

- 13.2.4. As from the date of entry into force, Contracting Parties applying this Regulation shall not refuse to grant extensions to approvals issued to the preceding series of amendments to this Regulation. However, as from [24] months after the entry into force of the 04 series of amendments extensions to approvals issued to the previous series of amendments shall not be granted in respect of vehicles having an electrical power train operating on high voltage

- 13.2.5. By way of derogation to the obligations of Contracting Parties applying this Regulation, where at the time of entry into force of the 04 series of

amendments to this Regulation national requirements exist to address the safety provisions detailed in these amendments, those Contracting Parties may continue to permit the entry into service of vehicles approved to the preceding series of amendments and complying with the specific national requirements applying at that time. This derogation shall cease to be valid [24] months after the entry into force of the 04 series of amendments to this Regulation.

- 13.2.6. As from [48] months after the entry into force of the 04 series of amendments to this Regulation, Contracting Parties applying this Regulation may refuse national or regional type approval and may refuse first national or regional registration (first entry into service) of a vehicle having an electrical power train operating on high voltage which does not meet the requirements of the 04 series of amendments to this Regulation.
- 13.3. Approvals of type of steering control
 - 13.3.1. Even after the date of entry into force of the 04 series of amendments, approvals of the steering control to the preceding series of amendments to the Regulation shall remain valid and Contracting Parties applying the Regulation shall continue to accept them, and Contracting Parties may continue to grant extensions of approvals to the 03 series of amendments.]”

Paragraph 13.3.2., shall be deleted.

Paragraphs 13.3.3. and 13.3.4., renumbered as paragraphs 13.3.2. and 13.3.3.

Annex 2, amend to read:

“Annex 2

Arrangements of approval marks

Model A

(See paragraph 4.2.4. of this Regulation)

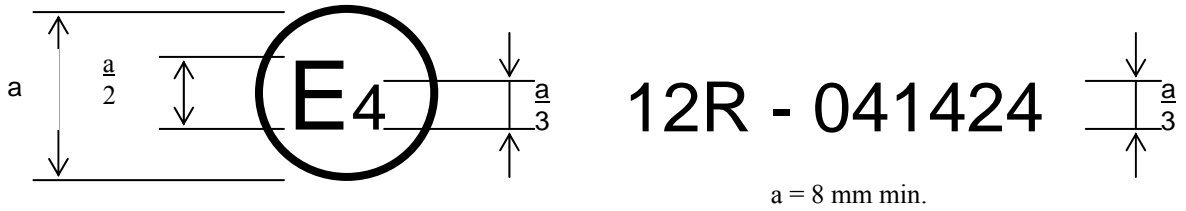

The above approval mark affixed to a vehicle shows that the vehicle type concerned has, with regard to the protection of the driver against the steering mechanism in the event of impact, been approved in the Netherlands (E4) pursuant to Regulation No. 12. The approval number indicates that the approval was granted according to the requirements of Regulation No. 12 as amended by the 04 series of amendments.

Model B

(See paragraph 4.2.5. of this Regulation)

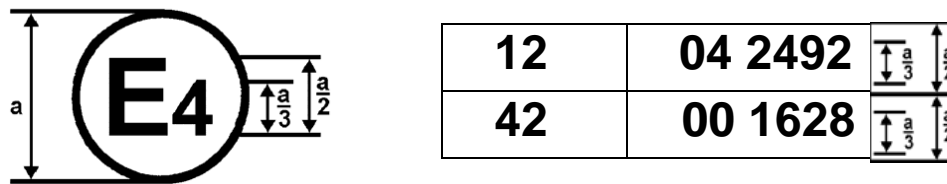

a = 8 mm min.

The above approval mark affixed to a vehicle shows that the vehicle type concerned has been approved in the Netherlands (E4) pursuant to Regulations Nos. 12 and 42.¹ The approval numbers indicate that, at the dates when the respective approvals were given, Regulation No. 12 included the 04 series of amendments and Regulation No. 42 the 00 series of amendments.

¹ The second number is given merely as an example.

Model C

(See paragraph 4.3.4. of this Regulation)

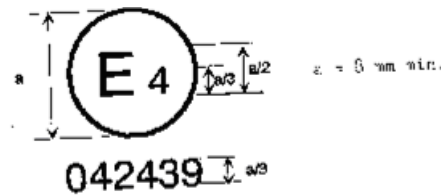

The above approval mark affixed to a steering control shows that the steering control type concerned has, with regard to the protection of the driver against the steering mechanism in the event of impact, been approved in the Netherlands (E4) pursuant to the relevant part of Regulation No. 12 as amended by the 04 series of amendments.”

Annex 3,

Paragraph 2.4.2., amend to read:

“2.4.2. If the vehicle is driven by external means, the fuel feed system shall be filled to at least 90 per cent of its capacity with a non-inflammable liquid having a density between 0.7 and 1.

This requirement does not apply for Hydrogen as fuel.

All the other systems (brake-fluid reservoirs, radiator, etc.) may be empty.”

Paragraph 2.4.3., amend to read:

“2.4.3. If the vehicle is driven by its own engine, the fuel tank shall be at least 90 per cent of a full load of fuel. All other reservoirs shall be filled to capacity.

It shall be allowed by agreement between manufacturer and Technical Service to modify the fuel system so that an appropriate amount of fuel can be used to run the engine or the electrical energy conversion system.

In such case, the fuel tank shall be filled to not less than 90 per cent of mass of a full load of fuel with a non-inflammable liquid of a density between 0.7 and 1.

This requirement does not apply to Hydrogen fuel tanks.”

Insert new paragraphs 2.4.4. to 2.4.4.2.2., to read:

“2.4.4. Electrical power train adjustment

2.4.4.1. The RESS shall be at any state of charge, which allows the normal operation of the power train as recommended by the manufacturer.

2.4.4.2. The electrical power train shall be energized with or without the operation of the original electrical energy sources (e.g. engine-generator, RESS or electric energy conversion system), however:

2.4.4.2.1. by the agreement between Technical Service and manufacturer it shall be permissible to perform the test with all or parts of the electrical power train not being energized in so far as there is no negative influence on the test result. For parts of the electrical power train not energized, the protection against electrical shock shall be proved by either physical protection or isolation resistance and appropriate additional evidence.

- 2.4.4.2.2. in the case where an automatic disconnect is provided, at the request of the manufacturer it shall be permissible to perform the test with the automatic disconnect being triggered. In this case it shall be demonstrated that the automatic disconnect would have operated during the impact test. This includes the automatic activation signal as well as the galvanic separation considering the conditions as seen during the impact.”

Paragraphs 2.4.4. and 2.4.5.(former) renumber as paragraphs 2.4.5. and 2.4.6.

Insert a new Annex 7 and its Appendix 1, to read:

“Annex 7

Test Procedures for the protection of the occupants of vehicles operating on electric power from high voltage and electrolyte spillage

This section describes test procedures to demonstrate compliance to the electrical safety requirements of paragraph 5.5. For example, megohmmeter or oscilloscope measurements are an appropriate alternative to the procedure described below for measuring isolation resistance. In this case it may be necessary to deactivate the on-board isolation resistance monitoring system.

Before the vehicle impact test conducted, the high voltage bus voltage (V_b) (see figure 1) shall be measured and recorded to confirm that it is within the operating voltage of the vehicle as specified by the vehicle manufacturer.

1. Test setup and equipment

If a high voltage disconnect function is used, measurements are to be taken from both sides of the device performing the disconnect function.

However, if the high voltage disconnect is integral to the RESS or the energy conversion system and the high-voltage bus of the RESS or the energy conversion system is protected according to protection IPXXB following the impact test, measurements may only be taken between the device performing the disconnect function and the electrical loads.

The voltmeter used in this test shall measure DC values and have an internal resistance of at least 10 M Ω .

2. The following instructions may be used if voltage is measured.

After the impact test, determine the high voltage bus voltages (V_b , V_1 , V_2) (see figure 1).

The voltage measurement shall be made not earlier than 5 seconds but not later than 60 seconds after the impact.

This procedure is not applicable if the test is performed under the condition where the electrical power train is not energized.

Figure 1
Measurement of V_b , V_1 , V_2

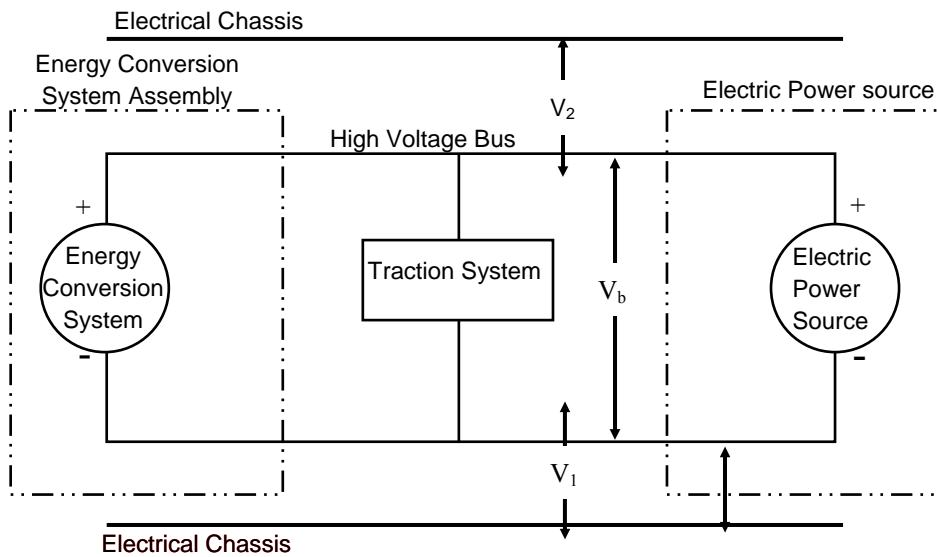

3. Assessment procedure for low electrical energy

Prior to the impact a switch S_1 and a known discharge resistor R_c is connected in parallel to the relevant capacitance (ref. figure 2).

Not earlier than 5 seconds and not later than 60 seconds after the impact the switch S_1 shall be closed while the voltage V_b and the current I_c are measured and recorded. The product of the voltage V_b and the current I_c shall be integrated over the period of time, starting from the moment when the switch S_1 is closed (t_c) until the voltage V_b falls below the high voltage threshold of 60 V DC (t_h). The resulting integration equals the total energy (TE) in joules:

$$(a) \quad TE = \int_{t_c}^{t_h} V_b \times I_c dt$$

When V_b is measured at a point in time between 5 seconds and 60 seconds after the impact and the capacitance of the X-capacitors (C_x) is specified by the manufacturer, total energy (TE) shall be calculated according to the following formula:

$$(b) \quad TE = 0.5 \times C_x \times (V_b^2 - 3600^2)$$

When V_1 , V_2 (see figure 1) are measured at a point in time between 5 seconds and 60 seconds after the impact and the capacitances of the Y-capacitors (C_{y1} , C_{y2}) are specified by the manufacturer, total energy (TE_{y1} , TE_{y2}) shall be calculated according to the following formulas:

$$(c) \quad TE_{y1} = 0.5 \times C_{y1} \times (V_1^2 - 3600^2)$$

$$TE_{y2} = 0.5 \times C_{y2} \times (V_2^2 - 3600^2)$$

This procedure is not applicable if the test is performed under the condition where the electrical power train is not energized.

Figure 2:
E.g. measurement of high voltage bus energy stored in X-capacitors

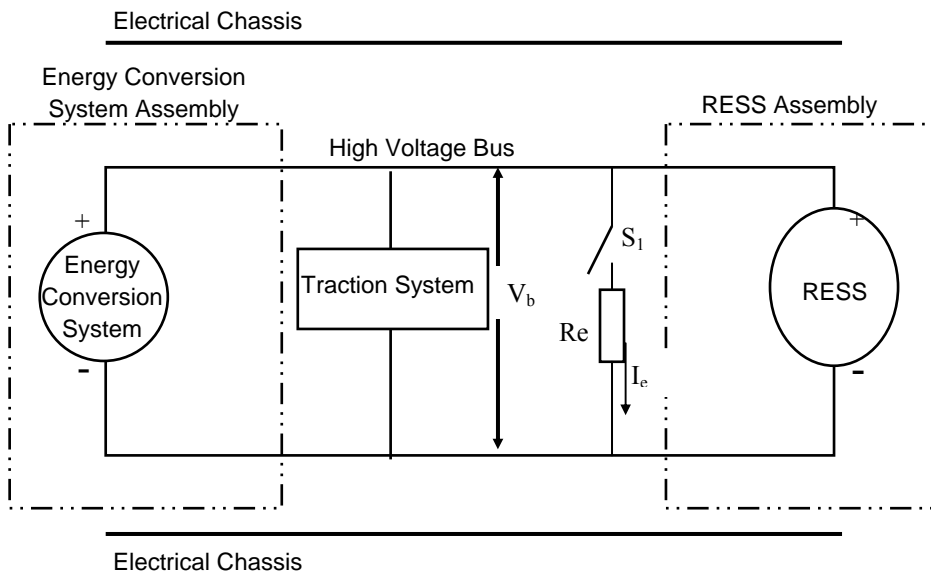

4. Physical protection

Following the vehicle impact test any parts surrounding the high voltage components shall be, without the use of tools, opened, disassembled or removed. All remaining surrounding parts shall be considered part of the physical protection.

The Jointed Test Finger described in Appendix 1 figure 1 shall be inserted into any gaps or openings of the physical protection with a test force of $10\text{ N} \pm 10\%$ per cent for electrical safety assessment. If partial or full penetration into the physical protection by the Jointed Test Finger occurs, the Jointed Test Finger shall be placed in every position as specified below.

Starting from the straight position, both joints of the test finger shall be rotated progressively through an angle of up to 90 degrees with respect to the axis of the adjoining section of the finger and shall be placed in every possible position.

Internal barriers are considered part of the enclosure.

If appropriate a low-voltage supply (of not less than 40 V and not more than 50 V) in series with a suitable lamp should be connected, between the Jointed Test Finger and high voltage live parts inside the electrical protection barrier or enclosure.

4.1. Acceptance conditions

The requirements of paragraph 5.5.1.3. shall be considered to be met if the Jointed Test Finger described in Appendix 1, figure 1 is unable to contact high voltage live parts.

If necessary a mirror or a fiberscope may be used in order to inspect whether the Jointed Test Finger touches the high voltage buses.

If this requirement is verified by a signal circuit between the Jointed Test Finger and high voltage live parts, the lamp shall not light.

5. Isolation resistance

The isolation resistance between the high voltage bus and the electrical chassis may be demonstrated either by measurement or by a combination of measurement and calculation.

The following instructions should be used if the isolation resistance is demonstrated by measurement.

Measure and record the voltage (V_b) between the negative and the positive side of the high voltage bus (see figure 1):

Measure and record the voltage (V_1) between the negative side of the high voltage bus and the electrical chassis (see figure 1):

Measure and record the voltage (V_2) between the positive side of the high voltage bus and the electrical chassis (see figure 1):

If V_1 is greater than or equal to V_2 , insert a standard known resistance (R_o) between the negative side of the high voltage bus and the electrical chassis. With R_o installed, measure the voltage (V_1') between the negative side of the high voltage bus and the vehicle electrical chassis (see figure 3). Calculate the isolation resistance (R_i) according to the formula shown below.

$$R_i = R_o * (V_b / V_1' - V_b / V_1) \quad \text{or} \quad R_i = R_o * V_b * (1 / V_1' - 1 / V_1)$$

Divide the result R_i , which is the electrical isolation resistance value (in Ω) by the working voltage of the high voltage bus in volt (V).

$$R_i (\Omega / V) = R_i (\Omega) / \text{Working voltage (V)}$$

Figure 3:
Measurement of V_1'

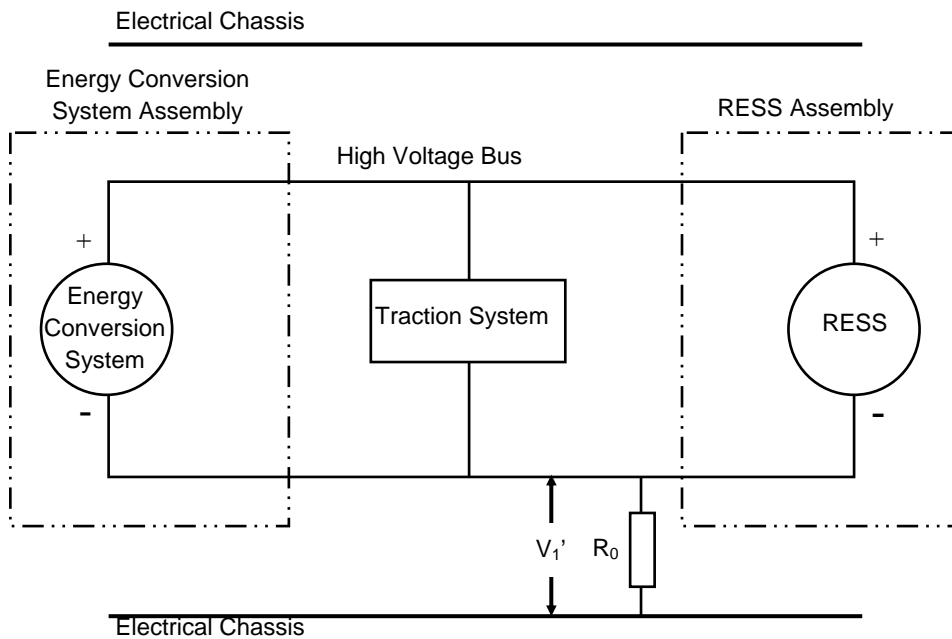

If V_2 is greater than V_1 , insert a standard known resistance (R_0) between the positive side of the high voltage bus and the electrical chassis. With R_0 installed, measure the voltage (V_2') between the positive side of the high voltage bus and the electrical chassis (see figure 4).

Calculate the isolation resistance (R_i) according to the formula shown below.

$$R^i = R_0 * (V_b / V_2' - V_b / V_2) \quad \text{or} \quad R_i = R_0 * V_b * (1 / V_2' - 1 / V_2)$$

Divide the result R_i , which is the electrical isolation resistance value (in Ω) by the working voltage of the high voltage bus in volt (V).

$$R_i (\Omega / V) = R_i (\Omega) / \text{Working voltage (V)}$$

Figure 4:
Measurement of V_2'

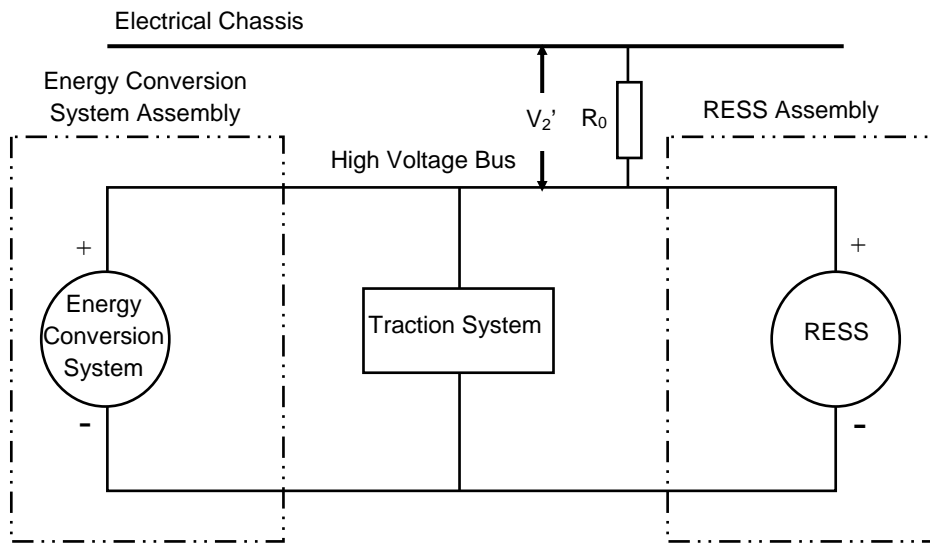

Electrical Chassis

NOTE 1: The standard known resistance R_0 (Ω) should be the value of the minimum required isolation resistance (Ω / V) multiplied by the working voltage of the vehicle plus/minus 20 per cent. R_0 is not required to be precisely this value since the equations are valid for any R_0 ; however, an R_0 value in this range should provide a good resolution for the voltage measurements.

6. Electrolyte spillage
Appropriate coating shall be applied, if necessary, to the physical protection in order to confirm any electrolyte leakage from the RESS after the impact test.
Unless the manufacturer provides means to differentiate between the leakage of different liquids, all liquid leakage shall be considered as the electrolyte.
7. RESS retention
Compliance shall be determined by visual inspection.

Appendix 1

Jointed Test Finger (IPXXB)

Figure 1:

Jointed test finger

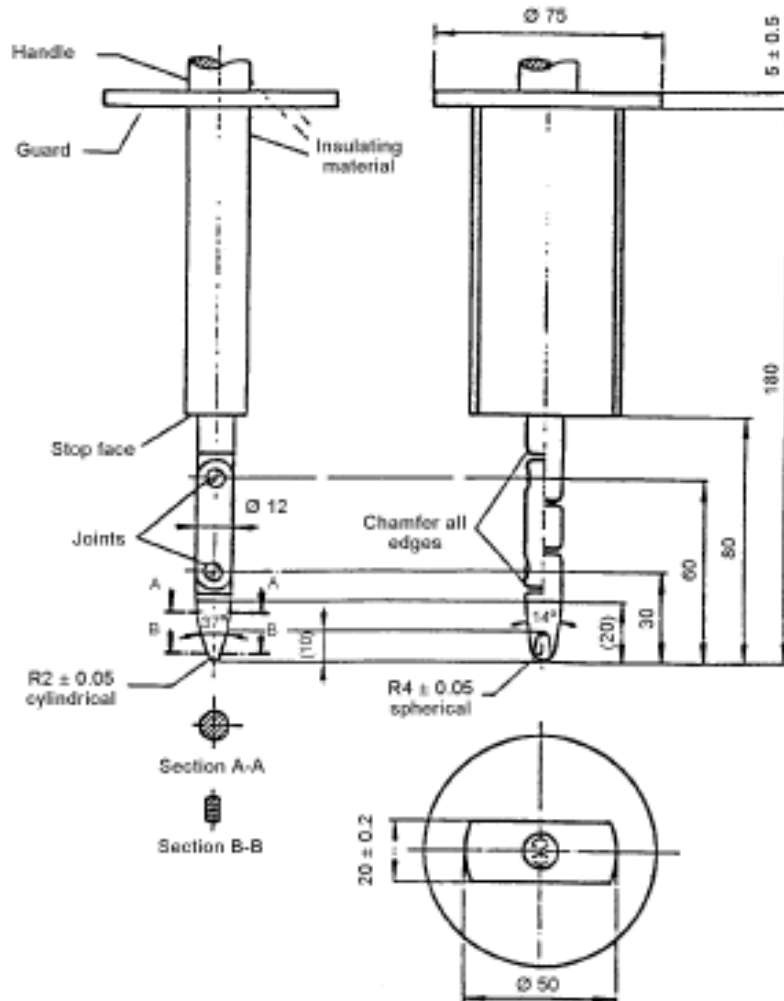

Material: metal, except where otherwise specified

Linear dimensions in millimeters

Tolerances on dimensions without specific tolerance:

- (a) on angles: $0/-10^\circ$
- (b) on linear dimensions: up to 25 mm: $0/-0.05$ mm over 25 mm: ± 0.2 mm

Both joints shall permit movement in the same plane and the same direction through an angle of 90° with a 0 to $+10^\circ$ tolerance.”