



**Economic and Social
Council**

Distr.
GENERAL

ECE/TRANS/WP.29/GRSG/76
8 December 2009

Original: ENGLISH

ECONOMIC COMMISSION FOR EUROPE

INLAND TRANSPORT COMMITTEE

World Forum for Harmonization of Vehicle Regulations

Working Party on General Safety Provisions

**REPORT OF THE WORKING PARTY ON GENERAL SAFETY PROVISIONS
ON ITS NINETY-SEVENTH SESSION
(Geneva, 20 to 23 October 2009)**

CONTENTS

	<u>Paragraphs</u>	<u>Page</u>
I. ATTENDANCE	1-2	4
II. ADOPTION OF THE AGENDA (Agenda item 1).....	3	4
III. REGULATION No. 66 (Strength of the superstructure) (Agenda item 2)	4	4
IV. REGULATION No. 107 (M ₂ and M ₃ vehicles) (Agenda item 3)	5-17	5
A. Proposals for further amendments (Agenda item 3(a)).....	5-13	5
B. Requirements for service doors, windows and emergency exits (Agenda item 3(b)).....	14-17	6

CONTENTS (continued)

	<u>Paragraphs</u>	<u>Page</u>
V. PROPOSAL FOR A NEW DRAFT REGULATION ON FRONTAL COLLISION OF BUSES (Agenda item 4)	18-19	7
VI. REGULATION No. 118 (Burning behaviour of materials) (Agenda item 5)	20-21	8
VII. REGULATION No. 34 (Fire risks) (Agenda item 6)	22-23	8
VIII. REGULATION No. 43 (Safety glazing) (Agenda item 7).....	24-27	9
IX. REGULATION No. 46 (Devices for indirect vision) (Agenda item 8)	28-31	10
X. REGULATION No. 73 (Lateral protection devices) (Agenda item 9)	32	10
XI. REGULATION No. 97 (Vehicle alarm systems (VAS)) (Agenda item 10)	33	11
XII. REGULATION No. 116 (Protection of motor vehicles against unauthorized use) (Agenda item 11)	34	11
XIII. REGULATION No. 122 (Heating systems of vehicles) (Agenda item 12)	35-36	11
XIV. REGULATION No. 125 (Forward field of vision of drivers) (Agenda item 13)	37-38	11
XV. GLOBAL TECHNICAL REGULATIONS UNDER THE 1998 AGREEMENT (Agenda item 14)	39-40	12
A. Proposal to develop a gtr on motorcycle controls, tell-tales and indicators (Agenda item 14(a)).....	39	12
B. Proposal to correct gtr No. 6 (safety glazing) (Agenda item 14(b)).....	40	12
XVI. GENERAL QUESTIONS RELATED TO THE SCOPE OF THE REGULATIONS ANNEXED TO THE 1958 AGREEMENT(Agenda item 15)	41	13
XVII. DEFINITION OF NON-ROAD MOBILE MACHINERY (Agenda item 16).....	42	13

CONTENTS (continued)

XVIII.	ALCOHOL IGNITION INTERLOCKS (Agenda item 17).....	43	13
XIX.	REVISIONS AND EXTENSIONS OF APPROVALS (Agenda item 18).....	44	14
XX.	PROPOSAL FOR DRAFT AMENDMENT TO THE CONSOLIDATED RESOLUTION ON THE CONSTRUCTION OF VEHICLES (R.E.3) (Agenda item 19).....	45	14
XXI.	ELECTION OF OFFICERS FOR 2010 (Agenda item 20).....	46	14
XXII.	OTHER BUSINESS (Agenda item 21)	47	14
	A. Regulation No. 58 (Rear under-run protection) (Agenda item 21(a)).....	47	14
XXIII.	AGENDA FOR THE NEXT SESSION	48	15

Annexes

I.	LIST OF INFORMAL DOCUMENTS DISTRIBUTED WITHOUT AN OFFICIAL SYMBOL DURING THE SESSION (GRSG-97-...)		16
II.	PROPOSAL FOR DRAFT AMENDMENTS TO REGULATION No. 107		20
III.	TERMS OF REFERENCE AND RULES OF PROCEDURE OF THE INFORMAL GROUP ON SERVICE DOORS, WINDOWS AND EMERGENCY EXITS OF BUSES AND COACHES (SDWEE)		21
IV.	PROPOSAL FOR DRAFT AMENDMENTS TO REGULATION No. 118		23
V.	PROPOSAL FOR DRAFT AMENDMENTS TO REGULATION No. 73		33
VI.	PROPOSAL FOR DRAFT AMENDMENTS TO REGULATION No. 125		35
VII.	INFORMAL GROUPS OF GRSG		37

I. ATTENDANCE

1. The Working Party on General Safety Provisions (GRSG) held its ninety-seventh session from 20 (afternoon) to 23 (afternoon) October 2009 in Geneva, under the chairmanship of Mr. A. Erario (Italy). Experts from the following countries participated in the work, following Rule 1(a) of the Rules of Procedure of the World Forum for Harmonization of Vehicle Regulations (WP.29) (TRANS/WP.29/690 and TRANS/WP.29/690/Amend.1): Belgium, Canada, China, Czech Republic, Finland, France, Germany, Hungary, India, Italy, Japan, Republic of Korea, Luxembourg, Netherlands, Norway, Poland, Russian Federation, South Africa, Spain, Sweden, Switzerland, United Kingdom of Great Britain and Northern Ireland and United States of America. A Representative of the European Commission (EC) also participated. Experts from the following non-governmental organizations participated: European Association of Automobile Suppliers (CLEPA), International Motorcycle Manufacturers Association (IMMA), International Organization for Standardization (ISO), International Organization of Motor Vehicle Manufacturers (OICA) and International Road Transport Union (IRU). Upon the special invitation of the Chairman, experts from the International Association of the Body and Trailer Building Industry (CLCCR) and the Transportation Technical Supervision (TDT) project participated.

2. The informal documents distributed during the session are listed in Annex I to this report.

II. ADOPTION OF THE AGENDA (Agenda item 1)

Documentation: ECE/TRANS/WP.29/GRSG/2009/1, informal documents No. GRSG-97-01 and GRSG-97-24

3. GRSG adopted the agenda proposed for the session (ECE/TRANS/WP.29/GRSG/2009/1 as amended by GRSG-97-24) with the insertion of new agenda items 14 (b) on a proposal to correct gtr No. 6 (safety glazing) and 21 (a) on Regulation No. 58 (Rear under-run protection). GRSG also adopted the running order (GRSG-97-01).

III. REGULATION No. 66 (Strength of superstructure) (Agenda item 2)

Documentation: Informal document No. GRSG-97-17

4. The expert from Hungary introduced GRSG-97-17 amending Regulation No. 66 to take into account the extension of its scope to double deckers. A number of experts were sceptical to this proposal and wondered in particular how the tests proposed for double deckers could be conducted in practice. The expert from EC questioned virtual testing for dynamic tests. He announced that the EC would make a proposal on this subject to WP.29 at its November 2009 session. GRSG agreed to resume consideration of this item at its next session and requested the secretariat to distribute GRSG-97-17 with an official symbol. .

IV. REGULATION No. 107 (M₂ and M₃ vehicles) (Agenda item 3)

A. Proposals for further amendments (Agenda item 3(a))

Documentation: ECE/TRANS/WP.29/GRSG/2009/10, ECE/TRANS/WP.29/GRSG/2009/12, ECE/TRANS/WP.29/GRSG/2009/15, ECE/TRANS/WP.29/GRSG/2009/17, informal documents Nos. GRSG-97-03, GRSG-97-05, GRSG-97-06, GRSG-97-07, GRSG-97-09, GRSG-97-13 and GRSG-97-16

5. The expert from Belgium introduced GRSG-97-09 superseding ECE/TRANS/WP.29/GRSG/2009/10 and introducing specific requirements for over-deck vehicles. GRSG adopted the document as reproduced in Annex II to this report and requested the secretariat to submit it to WP.29 and AC.1 for consideration at their March 2010 sessions, as part of proposal for Supplement 1 to the 03 series of amendments to Regulation No. 107 (see also paras. 7 and 15).

6. The expert from Spain introduced ECE/TRANS/WP.29/GRSG/2009/12 proposing to delete the references to Regulation No. 66 in Regulation No. 107. A majority of experts expressed preference for keeping this reference in Regulation No. 107. Consequently, GRSG agreed to remove ECE/TRANS/WP.29/GRSG/2009/12 from the agenda.

7. The expert from the United Kingdom presented ECE/TRANS/WP.29/GRSG/2009/15 correcting the provisions on priority seating of passengers with reduced mobility. The expert from Sweden introduced GRSG-97-13 amending ECE/TRANS/WP.29/GRSG/2009/12 with regard to paragraph 3.2.6 of Annex 8 to Regulation No. 107. GRSG could neither agree on the amendment to 3.2.6 of Annex 8 as proposed by ECE/TRANS/WP.29/GRSG/2009/12, nor as proposed by GRSG-97-13. GRSG agreed to resume consideration of this paragraph at its next session and required the secretariat to make GRSG-97-13 available with an official symbol. Furthermore, the expert from the United Kingdom volunteered to present a revised proposal as well as examples of vehicles meeting the requirements of the proposed paragraph 3.2.6. GRSG adopted the amendments to paragraphs 3.1. and 3.2.1 of Annex 8 to Regulation No. 107 as proposed in ECE/TRANS/WP.29/GRSG/2009/12 and requested the secretariat to submit them to WP.29 and AC.1 for consideration at their March 2010 sessions, as part of proposal for Supplement 1 to the 03 series of amendments to Regulation No. 107 (see also paras. 5 and 15).

8. The expert from France introduced ECE/TRANS/WP.29/GRSG/2009/17 correcting the French version of Regulation No. 107 in its Revision 2 and its Supplement 3 to 02 series of amendments. GRSG adopted the document and requested the secretariat to transform it as an erratum to Revision 2 of Regulation No. 107 and as an erratum to Supplement 3 to the 02 series of amendments to Regulation No. 107.

9. GRSG considered GRSG-97-03 aligning the Russian version of Revision 2 of Regulation No. 107 with the English version. GRSG adopted the document, not amended, and requested the secretariat to prepare it as an erratum to Revision 2 of Regulation No. 107.

10. The expert from the Russian Federation introduced GRSG-97-05 correcting the wording of Regulation No. 107 with regard to extinguishers. The expert from Germany proposed to amend slightly this proposal. GRSG adopted the document, as reproduced below, and requested the secretariat to submit it to WP.29 and AC.1 for consideration at their March 2010 sessions, as proposal for Corrigendum 2 to Revision 2 of Regulation No. 107.

Annex 3, paragraph 7.5.4.1., amend to read:

"7.5.4.1. Space shall be provided For vehicles of Class A or B, the space **for each required extinguisher** shall be not less...on the upper deck."

11. The expert from the Russian Federation introduced GRSG-97-06 regarding the strength of superstructure of single deck class B vehicles having a capacity not exceeding 16 passengers. GRSG supported this proposal in principle. However, the expert from OICA was of the opinion that transitional provisions should be included. The expert from the Russian Federation volunteered to prepare a revised proposal including transitional provisions for consideration by GRSG at its next session.

12. The expert from the Russian Federation presented GRSG-97-07 on the obligatory synchronized operation of the retractable steps and doors. GRSG agreed that the different language versions of Regulation No. 107 needed to be aligned in this regard. GRSG agreed to resume consideration of this item at its next session and requested the secretariat to distribute GRSG-97-07 with an official symbol.

13. The expert from Sweden introduced GRSG-97-16 concerning the legislation in his country on the transport in buses of children seated in prams. The expert from the EC stated that he supported the idea of straps for prams for all Class I, as applied in some buses in Sweden. He announced that he intended to make a proposal amending Regulation No.107 in this direction.

B. Requirements for service doors, windows and emergency exits (Agenda item 3 (b))

Documentation: ECE/TRANS/WP.29/GRSG/2009/13, ECE/TRANS/WP.29/GRSG/2009/16, informal documents Nos. GRSG-97-20, GRSG-97-23 and GRSG-97-29

14. GRSG considered ECE/TRANS/WP.29/GRSG/2009/13 proposed by the expert from France to correct Regulation No. 107 with regard to escape hatches and emergency exits. GRSG adopted the document, as corrected below, and requested the secretariat to submit it to WP.29 and AC.1 for consideration at their March 2010 sessions, as proposal for Supplement 6 to the 02 series of amendments to Regulation No. 107.

Page 2

For Supplement [6] read Supplement 6

For 24 months read 30 months

15. The expert from CLCCR introduced GRSG-97-20 and ECE/TRANS/WP.29/GRSG/2009/16 on escape hatches. GRSG agreed on the principle that it could be unsafe to fit escape hatches on certain vehicles, in particular trolley buses. Consequently, GRSG adopted the amendment to paragraph 7.6.1.11. of ECE/TRANS/WP.29/GRSG/2009/16 and requested the secretariat to submit this amendment to WP.29 and AC.1 for consideration at their March 2010 sessions, as part of proposal for Supplement 1 to the 03 series of amendments to Regulation No. 107 (see also paras. 5 and 7). GRSG could not agree on a wording to exempt other vehicles (e.g. gas vehicles with a tank on the roof). The expert from CLCCR agreed to prepare a revised proposal on these vehicles, for consideration by GRSG at its session.

16. The expert from Spain introduced GRSG-97-23 regarding the number of service doors of vehicles with more than 22 passengers and a short wheelbase. A number of experts supported this proposal in principle. GRSG agreed to resume consideration at its next session and requested the secretariat to distribute GRSG-97-23 with an official symbol.

17. The Chairman of the informal group on service doors, windows and emergency exits of buses and coaches (SWDEE) reported on the progress made by his group. He announced that three meetings of the informal group should be held in 2010. GRSG agreed to hold one of these meetings on Monday and Tuesday morning (one and half day) of the October 2010 GRSG session. GRSG also agreed that the bus items will be dealt at the beginning of this session. GRSG adopted GRSG-97-29 on the terms of reference and rules of procedures of the informal group as reproduced in Annex III of this report.

V. PROPOSAL FOR A NEW DRAFT REGULATION ON FRONTAL COLLISION OF BUSES (Agenda item 4)

Documentation: ECE/TRANS/WP.29/GRSG/2007/33, informal documents Nos. GRSG-95-20 and GRSG-97-18

18. The expert from Germany recalled ECE/TRANS/WP.29/GRSG/2007/33 and GRSG-95-20 concerning a draft Regulation on frontal collision of buses. A number of experts supported the principles of ECE/TRANS/WP.29/GRSG/2007/33 as a first step, but a majority of GRSG members did not support such regulation because their national data showed that such a regulation would have a very low impact on road safety compared to other measures. The expert from Germany recognized that he was not in a position to provide alternative road safety data to support his proposal.

19. GRSG was also informed that a working group of the European Enhanced Vehicle-safety Committee (EEVC) as well as the National Highway Traffic Safety Agency (NHTSA) were conducting research on the crash of buses and that the results of these studies were not yet available. The expert from EC and the United Kingdom announced that they would each launch a study on the improvement of safety in buses in the near future. Given what precedes, GRSG agreed to remove this item from the Agenda until new elements may bring support to ECE/TRANS/WP.29/GRSG/2007/33 and GRSG-95-20. Consequently, the expert from Hungary withdrew GRSG-97-18.

VI. REGULATION No. 118 (Burning behaviour of materials) (Agenda item 5)

Documentation: ECE/TRANS/WP.29/GRSG/2009/14, informal documents Nos. GRSG-97-27 GRSG-97-32, GRSG-97-32-Rev.1, GRSG-97-32-Rev.2, GRSG-97-34 and GRSG-97-35

20. The experts from France, Germany, Norway and Sweden presented GRSG-97-32-Rev.1 aiming to improve the fire safety of buses and superseding ECE/TRANS/WP.29/GRSG/2009/14, GRSG-97-27 and GRSG-97-32. GRSG followed with interest the presentation of GRSG-97-35 by the expert from Germany. He explained that, compared to ECE/TRANS/WP.29/GRSG/2009/14, GRSG-97-32-Rev.1 only covered cables and isolation materials and not the test of material in their real installation situation. The expert from Norway presented GRSG-97-34 showing that more research was needed before going further with the test of material in their real installation situation.

21. The expert from EC had a reservation on the transitional provisions of GRSG-97-32-Rev.1. Furthermore, a number of experts made editorial comments on GRSG-97-32-Rev.1. Consequently, the experts from France, Germany, Norway and Sweden produced GRSG-97-32-Rev.2. GRSG adopted the latter, as reproduced in Annex IV to this report, and requested the secretariat to submit it to WP.29 and AC.1 for consideration at their March 2010 sessions, as proposal for the 01 series of amendments to Regulation No. 118.

VII. REGULATION No. 34 (Fire risks) (Agenda item 6)

Documentation: ECE/TRANS/WP.29/GRSG/2009/21, informal documents GRSG-95-03

22. The expert from OICA presented ECE/TRANS/WP.29/GRSG/2009/21 proposing to exempt diesel vehicles from static electricity requirements. A number of experts were of the opinion that such an amendment should not be technology tailored but risk tailored. The expert from OICA agreed to prepare a revised proposal providing more justifications for consideration by GRSG at its next session.

23. The expert from the Netherlands recalled GRSG-95-03 concerning major fires in vehicles transporting dangerous goods (ADR) caused by leakage of fuel following an impact on the fuel tank. He explained that the informal document did not result in providing the requested information. GRSG agreed to delete this item from the agenda until new elements may help the discussion to progress. The expert from the Netherlands volunteered to ensure the necessary link with the current work carried out by the Working Party on the Transport of Dangerous Goods (WP.15).

VIII. REGULATION No. 43 (Safety glazing) (Agenda item 7)

Documentation: ECE/TRANS/WP.29/GRSG/2009/8, ECE/TRANS/WP.29/2009/125, informal documents Nos. GRSG-97-02, GRSG-97-02-Rev.1, GRSG-97-08, GRSG-97-08-Rev.1, GRSG-97-10 and GRSG-97-22

24. The expert from Germany recalled ECE/TRANS/WP.29/GRSG/2009/8 proposing to type approve rigid plastic windscreens and laminated rigid plastic panes other than windscreens. He presented further justifications in GRSG-97-22. A number of experts had reservations on this proposal and called for specific tests (i.e. abrasion) to take into account the specific constraints of plastic windscreens. The expert from Germany proposed that expert meetings be held with all interested stakeholders to develop a joint proposal. GRSG agreed to resume consideration of this subject at its next session on the basis of a revised proposal from Germany taking into account the comments made.

25. The expert from CLEPA introduced GRSG-97-02 and its Revision. 1 transposing gtr No. 6 into Regulation No. 43. He also presented GRSG-97-08 and its Revision. 1 as a consolidation of Regulation No. 43 up to Supplement 12. The expert from EC introduced ECE/TRANS/WP.29/2009/125, to be considered by WP.29 and AC.3 at their November 2009 sessions, and proposing to amend gtr No. 6 so that the current marking requirements in Regulation No. 43 would not need to be modified. GRSG agreed to wait for the decision of WP.29 and AC.3 on ECE/TRANS/WP.29/2009/125 at their November 2009 session before discussing GRSG-97-02-Rev.1 in detail. The expert from CLEPA agreed to prepare a revised proposal of GRSG-97-02-Rev.1 for consideration by GRSG at its May 2010 session. The GRSG Chairman requested all experts to send their comments on GRSG-97-02-Rev.1 and GRSG-97-08-Rev.1 to the expert from CLEPA by the end of December 2009. GRSG agreed to keep GRSG-97-08-Rev.1 as a reference document.

26. The expert from IMMA introduced GRSG-97-10 proposing to exclude L vehicles without bodywork from the scope of Regulation No. 43. GRSG adopted GRSG-97-10, as reproduced below, and requested the secretariat to submit it to WP.29 and AC.1 for consideration at their March 2010 sessions, as proposal for Supplement 13 to Regulation No. 43.

Paragraph 1., amend to read:

"1. SCOPE

This Regulation applies to:

(a) safety glazing materials intended for installation as windscreens or other panes, or as partitioning, on vehicles of category L **with bodywork**, M, N, O, and T 1/;

(b) vehicles of category ...";

27. The experts from France and EC pointed out that installation requirements of glazing for two and three wheel vehicles (L) and tractors (T) were missing in Regulation No. 43. GRSG

requested the experts from CLEPA, IMMA and OICA to review Annex 21 of the Regulation to include installation requirements for L and T vehicles.

IX. REGULATION No. 46 (Devices for indirect vision) (Agenda item 8)

Documentation: ECE/TRANS/WP.29/GRSG/2008/26, ECE/TRANS/WP.29/2009/99, ECE/TRANS/WP.29/GRSG/2009/19 and informal document No. GRSG-97-12

28. GRSG considered ECE/TRANS/WP.29/GRSG/2008/26 designed to cover M₁ vehicles with a seat back angle which can not be set to 25°. The experts from OICA and CLCCR considered such a case theoretical and that a proposal like this would create burden on industry with no benefit. A number of experts required more justification before adopting this proposal. GRSG agreed to resume the consideration of this subject at its next session on the basis of a revised proposal prepared by the expert from EC.

29. As agreed at its previous session, GRSG reviewed ECE/TRANS/WP.29/2009/99 clarifying the scope of Regulation No. 46. GRSG confirmed that ECE/TRANS/WP.29/2009/99 could be considered by WP.29 and AC.1 at their November 2009 sessions with no further change.

30. The Chairman of the informal group on Camera Monitor Systems (CMS) presented GRSG-97-12 on the progress made by his group. He informed GRSG that the last meeting of the informal group held on 10 September 2009 in Cologne (Germany) had been dedicated to the replacement of mirrors of class I to IV and class VII by CMS. He added that the group had decided to focus on the amendments needed for the replacement of mirrors by CMS in Regulation No. 46 and that several characteristics would be developed in an ISO standard. He announced that the next meeting of the informal group was scheduled to be held on 1 December 2009.

31. The expert from the United Kingdom introduced ECE/TRANS/WP.29/GRSG/2009/19 allowing the use of additional devices to extend the field of vision on the passenger side of N₂ and N₃ vehicles. A number of experts considered that the safety benefit of such a measure was low compare to the cost and that the wording of this proposal needed improvements. GRSG agreed to resume consideration of this subject at its next session on the basis of a revised proposal from the United Kingdom taking into account the comments made.

X. REGULATION No. 73 (Lateral protection devices) (Agenda item 9)

Documentation: ECE/TRANS/WP.29/GRSG/2009/18, informal document Nos. GRSG-97-26

32. The expert from CLCCR presented ECE/TRANS/WP.29/GRSG/2009/18 on the type approval of lateral protection devices as technical units. The expert from the United Kingdom introduced GRSG-97-26 to improve the wording of the proposal from CLCCR. GRSG adopted ECE/TRANS/WP.29/GRSG/2009/18, as amended by Annex V of this report, and requested the secretariat to submit it to WP.29 and AC.1 for consideration at their March 2010 sessions, as proposal for 01 series of amendments to Regulation No. 73.

XI. REGULATION No. 97 (Vehicle alarm system (VAS)) (Agenda item 10)

Documentation: ECE/TRANS/WP.29/GRSG/2008/5/Rev.2

33. For the same reasons mentioned in paragraph 34 below, the expert from Japan agreed to revise and update his proposal.

XII. REGULATION No. 116 (Protection of motor vehicles against unauthorized use) (Agenda item 11)

Documentation: ECE/TRANS/WP.29/GRSG/2008/4/Rev.3, informal document GRSG-97-21

34. The expert from Japan introduced GRSG-97-21 superseding ECE/TRANS/WP.29/GRSG/2008/4/Rev.3. The expert from OICA proposed amendments to this proposal. GRSG agreed to resume consideration of this subject at its next session on the basis of a revised document by the expert from Japan taking into account the comments made.

XIII. REGULATION No. 122 (Heating systems of vehicles) (Agenda item 12)

Documentation: ECE/TRANS/WP.29/GRSG/2009/22 and informal document GRSG-97-19

35. The expert from OICA presented ECE/TRANS/WP.29/GRSG/2009/22 introducing provisions for electric heating systems. The expert from CLEPA supported this proposal but expressed concerns on the type definition. GRSG agreed to resume consideration of this subject at its next session on the basis of a revised document prepared by the expert from OICA.

36. The expert from CLEPA introduced GRSG-97-19 to allow the use of the Liquid Petroleum Gas (LPG) heater of a trailer when the latter is in motion. The expert from the United Kingdom stated that it would be necessary to clarify the whole Annex 8 on LPG heaters. GRSG agreed to resume consideration of this subject at its next session on the basis of a revised proposal prepared by the expert from CLEPA. The GRSG Chairman invited all the experts to send their comments to the expert from CLEPA by the end of December to allow him to prepare an official proposal.

XIV. REGULATION No. 125 (Forward field of vision of drivers) (Agenda item 13)

Documentation: ECE/TRANS/WP.29/GRSG/2009/20, informal documents No. GRSG-97-11 GRSG-97-11-Rev.1, GRSG-97-25, GRSG-97-31 and GRSG-97-33

37. The expert from France introduced ECE/TRANS/WP.29/GRSG/2009/20 and GRSG-97-31 to update the provisions of Regulation No. 125 with regard head-up displays. The expert from OICA proposed GRSG-97-25 to improve the wording of the French proposal. GRSG adopted GRSG-97-25, as reproduced in Annex VI to this report, and requested the secretariat to submit it to WP.29 and AC.1 for consideration at their March 2010 sessions, as proposal for Supplement 2 to the original version of Regulation No. 125.

38. GRSG considered GRSG-97-11 and its Revision 1 proposed by the expert from Japan to improve the perception of motorcycles by car drivers. Several experts were concerned that this proposal could be in contradiction with GRSG-97-25. GRSG agreed to resume consideration of this item at its next session and requested the secretariat to distribute GRSG-97-11 with an official symbol.

**XV. GLOBAL TECHNICAL REGULATIONS UNDER THE 1998 AGREEMENT
(Agenda item 14)**

**A. Proposal to develop a gtr on motorcycle controls, tell-tales and indicators
(Agenda item 14(a))**

Documentation: ECE/TRANS/WP.29/AC.3 /22 and informal documents GRSG-97-14, GRSG-97-30 and GRSG-97-37

39. The expert from IMMA presented GRSG-97-30 on the progress of work on the gtr on motorcycle controls, tell-tales and indicators. GRSG agreed to set up, subject to the consent of WP.29, an informal group on this gtr under the chairmanship of Italy. The expert from IMMA volunteered to handle the secretariat tasks of the informal group. GRSG agreed to refer to the informal group GRSG-97-14 and GRSG-97-37. GRSG agreed to hold a meeting of the informal group in conjunction with the next session of GRSG (Monday morning).

B. Proposal to correct gtr No. 6 (safety glazing) (Agenda item 14(b))

Documentation: Informal document GRSG-97-15

40. The expert from Japan introduced GRSG-97-15 proposing to align the wording of paragraph 6.2.3.3.1. of gtr No. 6 with those of paragraph 5.5.1.1.6. GRSG adopted the document, as reproduced below, and requested the secretariat to submit it to WP.29 and AC.3 for consideration at their March 2010 session as draft Corrigendum 1 to gtr No. 6. The GRSG chairman agreed to inform WP.29/AC.3 at their November sessions about this upcoming corrigendum.

Paragraph 6.2.3.3.1., amend to read:

" 6.2.3.3.1. **Four panes for each point of impact** "

XVI. GENERAL QUESTIONS RELATED TO THE SCOPE OF THE REGULATIONS ANNEXED TO THE 1958 AGREEMENT (Agenda item 15)

Documentation: Informal document No. GRSG-96-06

41. The expert from Hungary recalled GRSG-96-06 proposing a systematic approach for the drafting of the scope of Regulations. He proposed to seek advice from the Office of Legal Affairs (OLA) on the way forward. The secretariat recalled the interpretation given by WP.29 and the Office of Legal Affairs (OLA) that approvals at the request of the manufacturer granted according to any Regulation shall be recognized by the Contacting Parties applying such a Regulation (ECE/TRANS/WP.29/1062, para. 31). The secretariat added that given what precedes, in his view, a further request to OLA would not be fruitful. The GRSG Chairman agreed to seek guidance from WP.29 on the way forward with the approaches proposed by GRSG-96-06.

XVII. DEFINITION OF NON-ROAD MOBILE MACHINERY (Agenda item 16)

Documentation: ECE/TRANS/WP.29/GRSG/2009/23

42. The secretariat introduced GRSG ECE/TRANS/WP.29/GRSG/2009/23 on the definition of mobile machinery proposed during the consideration of the draft Horizontal Regulation (ECE/TRANS/WP.29/2008/46). GRSG recognized that this definition only covered mobile machinery and not non-road mobile machinery. The expert from OICA informed GRSG that a definition on non-road mobile machinery already existed at in the European Community. GRSG agreed to consider at its next session a revised proposal prepared by the secretariat and based on the European Community definition on non-road mobile machinery.

XVIII. ALCOHOL IGNITION INTERLOCKS (Agenda item 17)

Documentation: Informal document No. GRSG-96-16

43. The expert from Sweden recalled GRSG-96-16 and explained that such devices were not type-approved but simply promoted in his country for some specific cases (i.e. school buses). He added that the technical requirements of such devices were covered by the standard EN 50436. The expert from France reminded GRSG that the installation requirements were not covered by EN 50436. However, given the lack of support for a regulation on this issue, GRSG agreed to remove this item from the agenda.

XIX. REVISIONS AND EXTENSIONS OF APPROVALS (Agenda item 18)

Documentation: ECE/TRANS/WP.29/GRSG/2009/24, informal document No. GRSG-97-36

44. The expert from OICA introduced ECE/TRANS/WP.29/GRSG/2009/24 amending Regulation No. 46, as an example of the use of the notion "revisions" in the framework of the 1958 Agreement. The expert from the Netherlands proposed in GRSG-97-36 to amend this proposal. GRSG agreed to resume consideration of this subject at its next session on the basis of a joint revised proposal by the experts from the Netherlands and OICA.

XX. PROPOSAL FOR DRAFT AMENDMENT TO THE CONSOLIDATED RESOLUTION ON THE CONSTRUCTION OF VEHICLES (R.E.3) (Agenda item 19)

Documentation: ECE/TRANS/WP.29/2009/123, informal document No. GRSG-97-04

45. The expert from the Russian Federation presented GRSG-97-04 on possible definitions for sleeper places and convertible places. Several experts had concerns over this proposal, in particular the lack of specific requirements for this type of places. The secretariat recalled that ECE/TRANS/WP.29/2009/123 proposing a revision of the Consolidated Resolution on the Construction of Vehicles (R.E.3) was on the agenda of the November session of WP.29/AC.1. GRSG agreed to wait for the decision of WP.29/AC.1 on the revision of R.E.3 before considering the amendment proposed by GRSG-97-04. GRSG agreed to resume consideration of this subject at its next session on the basis of a revised proposal by the expert from the Russian Federation.

XXI. ELECTION OF OFFICERS (Agenda item 20)

46. In compliance with Rule 37 of the Rules of Procedure (TRANS/WP.29/690 as amended by Amendment 1), GRSG called for the election of officers on 21 October 2009. Mr. A. Erario (Italy) was unanimously re-elected as Chairman and Mr. M. Matolcsy (Hungary) as Vice-Chairman for the GRSG sessions scheduled for the year 2010.

XXII. OTHER BUSINESS (Agenda item 21)

A. Regulation No. 58 (Rear under-run protection) (Agenda item 21(a))

Documentation: Informal document No. GRSG-97-28

47. The expert from EC presented GRSG-97-28 to extend the scope of Regulation No. 58 to certain categories of vehicles. He also proposed to transfer Regulation No. 58 to GRSP since this group already dealt with crash mitigation issues. GRSG was the opinion that Regulation No.58 should remain under its competence and asked the Chairman to seek guidance from WP.29 on the possible transfer to GRSP of this regulation. GRSG agreed to resume the consideration of the extension of the scope of the regulation and requested the secretariat to make GRSG-97-28 available with an official symbol.

XXII. AGENDA FOR THE NEXT SESSION

48. GRSG agreed on the following provisional agenda for the ninety-seventh session to be held in Geneva from 3 (starting at 2.30 p.m.) to 7 (concluding at 12.30 p.m.) May 2010¹. The deadline for submitting documents with an official symbol is 5 February 2010.

1. Adoption of the agenda
2. Regulation No. 66 (Strength of superstructure)
3. Regulation No. 107 (M₂ and M₃ vehicles):
 - 3(a) Proposals for further amendments;
 - 3(b) Requirements for service doors, windows and emergency exits;
4. Regulation No. 34 (Fire risks)
5. Regulation No. 43 (Safety glazing)
6. Regulation No. 46 (Devices for indirect vision)
7. Regulation No. 58 (Rear under run protection)
8. Regulation No. 97 (Vehicle alarm systems (VAS))
9. Regulation No. 116 (Protection of motor vehicles against unauthorized use)
10. Regulation No. 122 (Heating systems)
11. Regulation No. 125 (Forward field of vision of drivers)
12. Global technical regulations under the 1998 Agreement
- 13(a) Proposal to develop a gtr on motorcycle controls, tell-tales and indicators
13. General question related to the scope of the Regulations annexed to the 1958 Agreement
14. Definition of non-road mobile machinery
15. Revisions and extensions of approvals
16. Proposal for draft amendment to the consolidated Resolution on the Construction of Vehicles (R.E.3)
17. Other business

As agreed, the meeting of the informal group on the gtr on motorcycle controls, tell-tales and indicators will be held in the morning of 3 May 2010 (time to be confirmed by the chair of the informal group).

¹ To help experts make arrangements for travel and accommodation, the Chairman advises delegates that buses items should be discussed at the end of the session.

Annex ILIST OF INFORMAL DOCUMENTS (GRSG-97-...)
DISTRIBUTED WITHOUT AN OFFICIAL SYMBOL DURING THE SESSION

No.	Transmitted by	Agenda item	Language	Title	Follow-up
01	Chairman	1	E	Running order of the provisional agenda of the 97 th session of GRSG	(a)
02+ Rev.1	CLEPA	7	E	Proposal for draft amendments to Regulation No. 43 (safety glazing)	(a)
03	Russian federation	3(a)	R	Correction to Regulation No. 107 (M2 and M3 vehicles)	(d)
04	Russian Federation	19	E	Definition of bus classes for low floor bus of Class I with small length and large bus with sleeper places	(a)
05	Russian Federation	3(a)	E/R	Proposal for draft amendments to Regulation No. 107 (M2 and M3 vehicles)	(d)
06	Russian Federation	3(a)	E/R	Proposal for draft amendments to Regulation No. 107 (M2 and M3 vehicles)	(a)
07	Russian Federation	3(a)	E/R	Proposal for draft amendments to Regulation No. 107 (M2 and M3 vehicles)	(b)
08+ Rev.1	CLEPA	7	E	Proposal for draft amendments to Regulation No. 43 (safety glazing)	(e)
09	Belgium	3(a)	E	Proposal for draft amendments to Regulation No. 107 (M2 and M3 vehicles)	(d)
10	IMMA	7	E	Proposal for draft amendments to Regulation No. 43 (safety glazing)	(d)
11+ Rev.1	Japan	13	E	Proposal to review the requirements for forward field of vision in Regulation No.125 (Forward field of vision of drivers)	(b)
12	CMS Chairman	8	E	Report of the informal group on camera monitor systems	(a)
13	Sweden	3(a)	E	Comments and proposal to document ECE/TRANS/WP.29/GRSG/2009/15 (proposals for further amendments to Regulation No. 107)	(b)

No.	Transmitted by	Agenda item	Language	Title	Follow-up
14	European Commission	14(a)	E	Comments on the proposal for a gtr on motorcycle controls, tell-tales and indicators	(a)
15	Japan	14	E	Proposal for a corrigendum to gtr No.6 (safety glazing)	(d)
16	Sweden	3(a)	E	Information about prams in buses (Regulation No. 107)	(a)
17	Hungary	2	E	Further proposals to Regulation No. 66 (Strength of superstructure)	(b)
18	Hungary	4	E	Proposal for a new draft Regulation on frontal collision of buses	(a)
19	CLEPA	12	E	Proposal for amendments to Regulation No. 122 (Heating systems)	(a)
20	CLCCR	3(b)	E	Amendment to ECE/TRANS/WP.29/GRSG/2009/16 (Regulation No. 107)	(a)
21	Japan	11	E	Revised proposal for draft amendments to Regulation No. 116	(a)
22	Germany	7	E	Justifications on ECE/TRANS/WP.29/GRSG/2009/8. regarding Regulation No. 43 (Safety Glazing)	(a)
23	Spain	3(b)	E	Proposal for draft amendments to Regulation No. 107 (service doors)	(b)
24	Secretariat	1	E	Update of the provisional agenda	(a)
25	OICA	13	E	Proposal for draft amendments to Regulation No. 125 (Forward field of vision of drivers)	(d)
26	United Kingdom	9	E	Amendment to ECE/TRANS/WP.29/GRSG/2009/18 (Regulation No. 73)	(a)
27	France, Germany, Norway and Sweden	5	E	Proposal for draft amendments to Regulation No. 118 (Burning behaviour of Materials)	(a)

No.	Transmitted by	Agenda item	Language	Title	Follow-up
28	EC	21	E	Proposal for draft amendments to Regulation No. 58 (Rear underrun protection)	(b)
29	SDWEE Chairman	3(a)	E	Draft terms of reference and rules of procedure of the informal Group on service doors, windows and emergency exits (SDWEE)	(a)
30	IMMA	14(a)	E	Current status of the draft gtr on the location and identification of motorcycle controls, tell-tales and indicators	(a)
31	France	13	E	Presentation on the proposal for draft amendments to the Regulation on Driver's Forward Field of Vision	(a)
32+ Rev.1 and Rev2	France, Germany, Norway and Sweden	5	E	Draft amendments to Regulation No. 118	(d)
33	Japan	13	E	Presentation from Japan on GRSG-97-11 (Regulation 125)	(a)
34	Norway	5	E	Presentation on a comparative study of test methods for assessment of fire safety performance of bus interior materials (Regulation No. 118)	(a)
35	Germany	5	E	Presentation on fire Safety in Buses and Coaches (Regulation No. 118)	(a)
36	Netherlands	18	E	Proposal for amendments to ECE/TRANS/WP.29/GRSG/2009/24 (Revisions and extensions of approvals)	(a)
37	IMMA	14(a)	E	Draft terms of reference and rules of procedure of the informal Group for preparing a gtr on the location and identification of motorcycle controls, tell-tales and indicators	(a)

No.	Transmitted by	Agenda item	Language	Title	Follow-up
Reconsideration of informal documents from the previous sessions of GRSG (referring to agenda item and follow-up decision of the current session)					
95-03	Netherlands	6	E	Consideration for draft amendments to Regulation 34 (Prevention of fire risks)	(a)
95-20	Germany	4	E	Proposal for a new regulation for vehicles of category M ₃ with regard to the protection of the driver and crew member(s) seated alongside the driver in the case of a frontal collision	(a)
96-6	Hungary and Russian Federation	15	E	The structure and the content of the scopes of regulations belonging to the 1958 Agreement	(e)

Notes:

- (a) Consideration completed or to be superseded
- (b) Continue consideration at the next GRSG session as an official document
- (c) Continue consideration at the next GRSG session as an informal document
- (d) Adopted and to be submitted to WP.29
- (e) Reference document for further sessions

Annex IIPROPOSAL FOR DRAFT AMENDMENTS TO REGULATION No. 107
GRSG-97-09 ADOPTED AS FOLLOWS

(see para. 5. of this report)

The modifications to the current text of the Regulation are marked in bold characters.

Paragraph 2.14., amend to read:

"2.14. "Floor or deck":"

Insert new paragraphs 2.14.1 and 2.14.2., to read:

"2.14.1. "Floor" means that part of the bodywork whose upper surface supports standing passengers, the feet of seated passengers and the driver and any crew member, and may support the seat mountings;**2.14.2. "Deck" means that part of the floor provided only for the passengers."**

Annex 4, Figure 6, insert a new footnote 5/ in the table, to read:

"

Single deck						
Class	B (mm)	C (mm)	D (mm)	E (mm)	F (mm)	
A	550	350	500 <u>4/</u>	1,900 <u>4/</u>	900	
B	450	300	300	1,500	900	
I	550	450 <u>3/</u>	500 <u>4/</u>	1,900 <u>4/</u>	900	
II	550	350	500 <u>4/</u>	1,900 <u>4/</u>	900	
III	450	300 <u>2/</u>	500 <u>4/</u>	1,900 <u>4/</u> <u>5/</u>	900 <u>5/</u>	
Double deck						
I	LD	550	450 <u>3/</u>	500	1,800 <u>1/</u>	1,020 <u>1/</u>
	UD	550	450 <u>3/</u>	500	1,680	900
II	LD	550	350	500	1,800 <u>1/</u>	1,020 <u>1/</u>
	UD	550	350	500	1,680	900
III	LD	450	300 <u>2/</u>	500	1,800 <u>1/</u>	1,020 <u>1/</u>
	UD	450	300 <u>2/</u>	500	1,680	900

5/ In the case of a vehicle with part of its deck directly over the driver's compartment, the overall height of the gauging device may be reduced (by reducing the height of the lower cylinder) from 1,900 mm to 1,680 mm in any part of the gangway forward to a transverse vertical plane which coincides with the centre line of the front axle."

Annex III

TERMS OF REFERENCE AND RULES OF PROCEDURE
OF THE INFORMAL GROUP ON SERVICE DOORS, WINDOWS
AND EMERGENCY EXITS OF BUSES AND COACHES (SDWEE)
(see para. 17 of this report)

TERMS OF REFERENCE

1. The informal group on service doors, windows and emergency exits of buses and coaches was established upon the consent of the WP.29 at its 148th session (document: ECE/TRANS/WP.29/1077, paragraph 43).
2. The informal group shall prepare draft regulatory proposals to amend the requirements of Regulation 107 annexed to the 1958 Agreement that are related to service doors, windows and emergency exits of buses and coaches.
3. The group will focus on vehicles of category M₂ or M₃, as defined in paragraph 1.1. of Regulation 107.
4. The group should take full account of existing data and research in developing its regulatory proposals. It should also consider pre-existing standards (e.g. ISO, SAE) and national legislations for service doors, windows and emergency exits of buses and coaches in developing its proposals.
5. Draft regulatory texts should be submitted to the one hundredth session of GRSG in April 2011.
6. The target completion date for the work of the informal group shall be the one hundred first session of GRSG in October 2011.
7. These targets will be reviewed in October 2010.

RULES OF PROCEDURE

1. The informal group is a sub group of GRSG, and is open to all participants of GRSG.
2. A Chairman and a Secretary will manage the informal group.
3. The official language of the informal group will be English.
4. All documents and/or proposals must be submitted to the Secretary of the group in a suitable electronic format in advance of the meeting. The group may refuse to discuss any item or proposal which has not been circulated 10 working days in advance.

5. An agenda and related documents will be circulated to all members of the informal group in advance of all scheduled meetings.
6. Recommendations to GRSG will be reached by consensus. When consensus cannot be reached, the Chairman of the group shall present the different points of view to GRSG. The Chairman may seek guidance from GRSG as appropriate.
7. The progress of the informal group will be routinely reported to GRSG – by means of an informal document and presented by the Chairman or his representative.
8. All working documents should be distributed in digital format. Meeting documents should be made available to the UNECE secretariat for publication on the website of WP.29.

Annex IV

PROPOSAL FOR DRAFT AMENDMENTS TO REGULATION No. 118
GRSG-97-32-Rev.2 adopted as follows (superseding ECE/TRANS/WP.29/GRSG/2009/14)
(see para. 21 of this report)

The modifications to the current text of the Regulation are marked in bold characters.

The title of the Regulation, amend to read:

"UNIFORM TECHNICAL PRESCRIPTIONS CONCERNING THE BURNING
BEHAVIOUR **AND/OR THE CAPABILITY TO REPEL FUEL OR LUBRICANT** OF
MATERIALS USED IN THE CONSTRUCTION OF CERTAIN CATEGORIES OF MOTOR
VEHICLES"

The list of contents, amend to read:

"Regulation No. 118

UNIFORM TECHNICAL PRESCRIPTIONS CONCERNING THE BURNING BEHAVIOUR
AND/OR THE CAPABILITY TO REPEL FUEL OR LUBRICANT OF MATERIALS
USED IN THE CONSTRUCTION OF CERTAIN CATEGORIES OF MOTOR VEHICLES

.....

12. Transitional Provisions

.....

Annex 9- Test to determine the capability of materials to repel fuel or lubricant"

The text of the Regulation

Paragraphs 1. to 1.3., amend to read:

"1. SCOPE

1.1. This Regulation applies to the burning behaviour (ignitibility, burning rate and melting behaviour) **and to the capability to repel fuel or lubricants** of materials used in vehicles of categories **M₃, Classes II and III** 2/.

Type approvals are granted according to:

1.2. Part I - Approval of a vehicle type with regard to the burning behaviour **and/or the capability to repel fuel or lubricant** of the components used in the **interior**

2/ As defined in the Consolidated Resolution on the Construction of Vehicles (R.E.3), Annex 7 (document TRANS/WP.29/78/Rev.1/Amend.2).

compartment, **the engine compartment and any separate heating compartment.**

- 1.3. Part II - Approval of a component with regard to its burning behaviour **and/or its capability to repel fuel or lubricant installed in the passenger compartment, the engine compartment or any separate heating compartment.**"

Insert new paragraphs 2.3. and 2.4., to read:

"2.3. **"Engine compartment" means the compartment in which the engine is installed and in which a combustion heater may be installed.**

2.4. **"Separate heating compartment" means a compartment for a combustion heater located outside the interior compartment and the engine compartment.**"

Paragraphs 2.3 (former) to 2.6., renumber as paragraphs 2.5. to 2.8.

Paragraphs 3.3.2. to 3.3.3.1., amend to read:

"3.3.2. In the case of **components** already type approved: a list of the type approval numbers and maker's type designations of the parts concerned, shall be enclosed in the application for the vehicle type approval;

3.3.3. In the case of **components** without ECE type approval:

3.3.3.1. Samples, the number of which is specified in Annexes 6 to **9**, of the components used in the vehicles, which are representative of the type to be approved;"

Paragraph 4.2., amend to read:

"4.2. An approval number... (at present **01 corresponding to the 01 series of amendments**) shall indicate..."

Paragraph 4.4.1., amend footnote 2/ to read:

"2/ 1 for Germany, ... 50 for Malta, 51 for the Republic of Korea, **52 for Malaysia, 53 for Thailand, 54 and 55 (vacant), 56 for Montenegro, 57 (vacant) and 58 for Tunisia.** Subsequent numbers shall ... the Agreement."

Paragraph 5., amend to read:

"5. PART I: APPROVAL OF A VEHICLE TYPE WITH REGARD TO THE BURNING BEHAVIOUR OF THE **COMPONENTS USED IN THE INTERIOR COMPARTMENT, THE ENGINE COMPARTMENT AND ANY SEPARATE HEATING COMPARTMENT AND/OR THE CAPABILITY TO REPEL FUEL OR LUBRICANT OF INSULATION MATERIALS USED IN THE ENGINE COMPARTMENT AND ANY SEPARATE HEATING COMPARTMENT**"

Paragraphs 5.2.1. to 5.2.3., amend to read:

"5.2.1. The **materials** of the passenger compartment, **the engine compartment and any separate heating compartment** used in the vehicle to be type approved shall meet the requirements of Part II of this Regulation.

5.2.2. The materials and/or equipment used in the passenger compartment, **the engine compartment and any separate heating compartment** and/or in devices approved as components shall be so installed as to minimize the risk of flame development and flame propagation.

5.2.3. Such **materials** and/or equipment shall only be installed in accordance with their intended purposes and the test(s) which they have undergone (see paragraphs 6.2.1., 6.2.2., **6.2.3., 6.2.4., 6.2.5. and 6.2.6.**), especially in relation to their burning and melting behaviour (horizontal/vertical direction) **and/or their capability to repel fuel or lubricant.**"

Paragraph 6., amend to read:

"6. PART II: APPROVAL OF A COMPONENT WITH REGARD TO ITS BURNING BEHAVIOUR **AND/OR ITS CAPABILITY TO REPEL FUEL OR LUBRICANT**"

Paragraph 6.1.1.2., amend to read:

"6.1.1.2. the intended use (seat upholstery, roof lining, **insulation**, etc.),"

Paragraph 6.1.4., amend to read:

"6.1.4. "Exposed face" means the side of a material which is facing towards the passenger compartment, **the engine compartment and any separate heating compartment** when the material is mounted in the vehicle."

Insert new paragraphs 6.1.7. and 6.1.8., to read:

"**6.1.7. "Insulation material(s)" means material(s) used to reduce heat transfer by conduction, radiation or convection and for sound-proofing in the engine compartment and any separate heating compartment.**

6.1.8. "Capability to repel fuel or lubricant" means the capability of materials to repel fuel or lubricant when measured according to Annex 9 to this Regulation."

Insert new paragraphs 6.2.4 and 6.2.5., to read:

"6.2.4. All insulation material(s) installed in the engine compartment and any separate heating compartment shall undergo the test described in Annex 9 to this Regulation.

The result of the test shall be considered satisfactory if, taking the worst test results into account, the increase of the weight of the test sample does not exceed 1 g.

Recesses necessary for technical reasons, e.g. tubes or structural members that need to pass through the material shall be allowed as long as the protection is maintained (e.g. sealant, tape ...).

6.2.5. Electric cables shall undergo the resistance to flame propagation test described in ISO standard 6722:2006, paragraph 12.

The result of the test shall be considered satisfactory if, taking into account the worst test result, any combustion flame of insulating material shall extinguish within 70 seconds and a minimum of 50 mm insulation at the top of the test sample shall remain unburned."

Paragraphs 6.2.4.(former) to 6.2.4.3.2., renumber as paragraphs 6.2.6. to 6.2.6.3.2.

Paragraph 6.2.4.4., should be deleted.

Paragraph 6.2.4.5., renumber as paragraph 6.2.6.4.

Insert new paragraphs 12. to 12.5., to read:

"12. TRANSITIONAL PROVISIONS

12.1. As from the official date of entry into force of the 01 series of amendments, no Contracting Party applying this Regulation shall refuse to grant ECE approval under this Regulation as amended by the 01 series of amendment.

12.2. As from 24 months after the official date of entry into force of the 01 series of amendments, Contracting Parties applying this Regulation shall grant ECE approvals only if the vehicle type or component type to be approved meet the requirements of this Regulation as amended by the 01 series of amendments.

- 12.3. Starting from 60 months after the official date of entry into force of the 01 series of amendments, Contracting Parties applying this Regulation may refuse first national or regional registration (first entry into service) of a vehicle which does not meet the requirements of this Regulation as amended by the 01 series of amendments.
- 12.4. Even after the date of entry into force of the 01 series of amendments to this regulation, approvals of the components to the preceding series of amendments to the regulation shall remain valid and Contracting Parties applying this Regulation shall continue to accept them.
- 12.5. Contracting Parties applying this Regulation shall not refuse to grant extensions of approval to the 00 series of amendments to this Regulation."

Annex 1,

The title, amend to read:

"INFORMATION DOCUMENT

(in accordance with paragraph 3.2. of this Regulation relating to the ECE Type Approval of a vehicle with regard to the burning behaviour of the **components** used in the passenger compartment, **the engine compartment and any separate heating compartment and/or the capability to repel fuel or lubricant of insulation materials used in the engine compartment and any separate heating compartment)**"

Paragraph 3., amend to read:

"3. BODYWORK
Interior fittings **and/or insulation materials**"

Insert new paragraphs 3.3., 3.3.1., 3.3.1.1., 3.4. and 3.4.1., to read:

- "3.3. **Capability of materials to repel fuel or lubricant used in the vehicle**
- 3.3.1. **Material(s) used for insulation purposes**
- 3.3.1.1. **Component type-approval number(s):**
- 3.4. **Electric cables**
- 3.4.1. **Component type-approval number(s):**"

Annex 2

The title, amend to read:

"INFORMATION DOCUMENT

(in accordance with paragraph 3.2. of the Regulation relating to the ECE Type Approval of a component **used in the passenger compartment, the engine compartment and any separate heating compartment** with regard to its burning behaviour **and/or the capability to repel fuel or lubricant of insulation materials used in the engine compartment and any separate heating compartment**)"

Insert new paragraphs 3. to 3.6. and paragraphs 4. to 4.6., to read:

- "3. **INSULATION MATERIALS**
- 3.1. **Material(s) used for:**
- 3.2. **Base material(s)/designation:** . . . /
- 3.3. **Composite/single (1/) material, number of layers 1/:**
- 3.4. **Type of coating (1/):**
- 3.5. **Maximum/minimum thickness**mm
- 3.6. **Type-approval number, if available:**

- 4. **ELECTRIC CABLES**
- 4.1. **Material(s) used for:**
- 4.2. **Base material(s)/designation:** . . . /
- 4.3. **Composite/single (1/) material, number of layers 1/:**
- 4.4. **Type of coating (1/):**
- 4.5. **Maximum/minimum thickness**mm
- 4.6. **Type-approval number, if available:**

Annex 5, amend to read:

"Annex 5
 ARRANGEMENTS OF APPROVAL MARKS

Example 1

(see Part I of this Regulation)

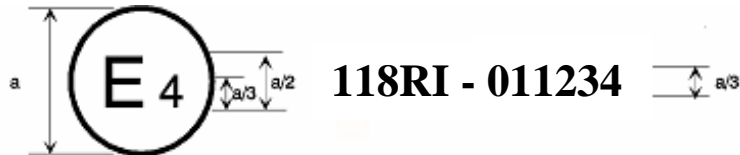

a = 8 mm min

The above approval mark affixed to a vehicle shows that the type concerned was approved in the Netherlands (E4) pursuant to Part I of Regulation No. 118 under approval No. **011234**. The first two digits (**01**) of the approval number indicate that the approval was granted in accordance with the requirements of the **01 series of amendments to Regulation No. 118**.

Example 2

(see part II of this Regulation)

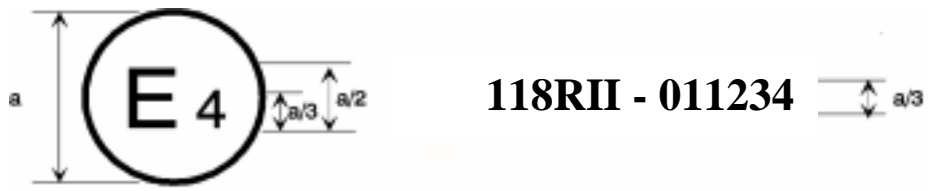

a = 8 mm min

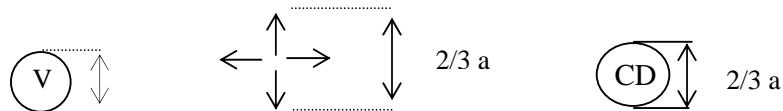

The above approval mark affixed to a component shows that the type concerned was approved in the Netherlands (E4) pursuant to Part II of Regulation No. 118 under approval number **011234**. The first two digits (**01**) of the approval number indicate that the approval was granted in accordance with the requirements of the **01 series of amendments to Regulation No. 118**.

The additional symbol..."

Insert a new Annex 9, to read:

"Annex 9

**TEST TO DETERMINE THE CAPABILITY OF MATERIALS TO REPEL
FUEL OR LUBRICANT**

1. Scope

This annex lists prescriptions to test the capability of insulation materials used in engine compartments and separate heating compartments.

2. Sampling and principle

2.1. The test samples shall measure: 140 mm x 140 mm.

2.2. The thickness of the samples shall be 5mm. If the thickness of the test sample is more than 5 mm, it shall be reduced to 5 mm by a mechanical process applied to the side which does not face the engine compartment or separate heating compartment.

2.3. The test liquid shall be diesel fuel according to standard EN 590:1999 (Market fuels), or alternatively diesel fuel according to ECE Regulation No. 83 (Annex 10: Specification of reference fuels).

2.4. Four samples shall undergo the test.

3. Apparatus (see figures 4a and 4b)

The apparatus shall consist of:

- A a base plate, with a hardness of at least 70 Shore D.**
- B an absorbant surface on the baseplate (e.g. paper);**
- C a metal cylinder (inner diameter of 120 mm, outer diameter of 130 mm, height of 50 mm), filled with the test liquid;**
- D-D' two screws with wing nuts;**
- E the test sample;**
- F top plate**

4. Procedure

- 4.1. The test sample and the apparatus shall be conditioned for at least 24 hours at a temperature of $23 \pm 2^{\circ}\text{C}$ and a relative humidity of 50 ± 5 per cent and shall be maintained under these conditions until immediately prior to testing.
- 4.2. The test sample shall be weighed.
- 4.3. The test sample, with its exposed face uppermost, shall be placed on the base of the apparatus by fixing the metal cylinder in a centred position with sufficient pressure on the screws. No test liquid shall leak.
- 4.4. Fill the metal cylinder with test liquid to a height of 20 mm and let the system rest for 24 hours.
- 4.5. Remove the test liquid and the test sample from the apparatus. If residue of the test liquid is found on the test sample it shall be removed without compressing the test sample.
- 4.6. The test sample shall be weighed.

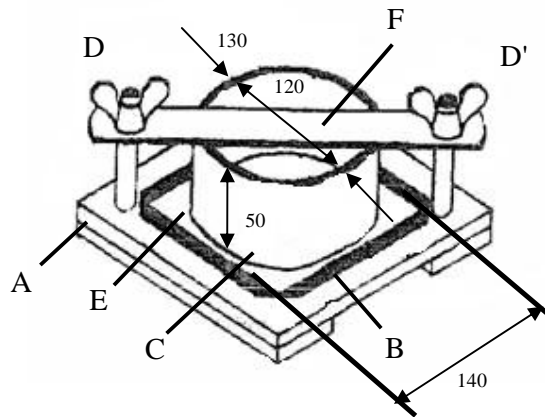

Figure 4a
Apparatus for testing the capability to repel fuel or lubricant
(Dimensions in millimeters)"

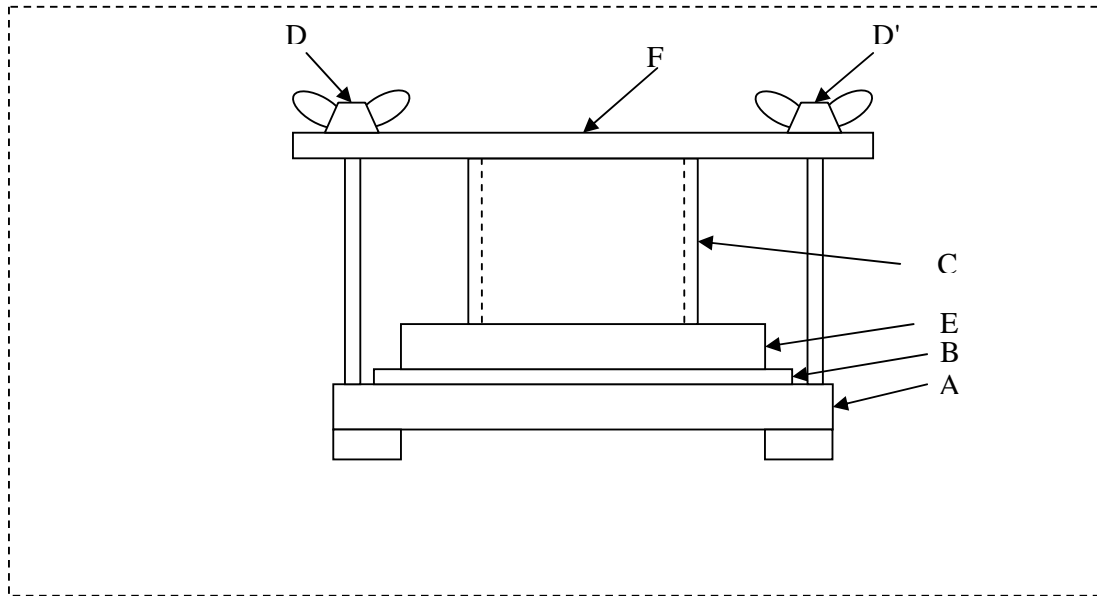

Figure 4b
Apparatus for testing the capability to repel fuel or lubricant
(Side View)"

Annex V

PROPOSAL FOR DRAFT AMENDMENTS TO REGULATION No. 73
ECE/TRANS/WP.29/GRSG/2009/18 amended as follows
(see para. 32 of this report)

New paragraphs 1.1.1. to 1.1.3 and 1.2.2.

For LPD read Lateral protection devices

New paragraph 2.1.4.

For Lateral protection device read Lateral Protection Device (LPD)

New paragraph 11.2.

For [xx] months read 12 months

New paragraph 12.2., correct to read:

"12.2. The outer surface of the LPD shall be smooth, and so far as possible continuous from front to rear; adjacent parts may however overlap provided that the overlapping edge faces rearwards or downwards, or a gap of not more than 25 mm measured longitudinally may be left, provided that the rearward part does not protrude outboard of the forward part; domed heads of bolts or rivets may protrude beyond the surface to a distance not exceeding 10 mm and other parts may protrude to the same extent provided that they are smooth and similarly rounded; all external edges and corners that may be contacted by a sphere of 100 mm diameter shall be rounded with a radius not less than 2.5 mm; those protruding less than 5 mm shall have blunted outward facing edges".

New paragraph 12.6.

For [1900] read 2100

New paragraph 12.10., last indent, delete ", e.g. on the basis of a comparative test with a similar LPD"

New paragraph 13.1.5, correct to read:

"13.1.5. On a vehicle fitted with a crane for loading, unloading or other operations for which the vehicle is designed, making it impracticable to comply with all the requirements of paragraph 12., the LPD may be arranged with additional gaps where these are necessary to permit the movement or stowage of the crane."

New paragraphs 14.1., correct to read:

"14.1. The outer surface of the LPD shall be smooth, and so far as possible continuous from front to rear; adjacent parts may however overlap provided that the overlapping edge faces rearwards or downwards, or a gap of not more than 25 mm measured longitudinally may be left, provided that the rearward part does not protrude outboard of the forward part; domed heads of bolts or rivets may protrude beyond the surface to a distance not exceeding 10 mm and other parts may protrude to the same extent provided that they are smooth and similarly rounded; all external edges and corners that may be contacted by a sphere of 100 mm diameter shall be rounded with a radius not less than 2.5 mm; those protruding less than 5 mm shall have blunted outward facing edges".

New paragraph 14.4., last indent, delete ", e.g. on the basis of a comparative test with a similar LPD"

New paragraph 15.4.

For [1900] read 2100

New paragraph 16.1.5, correct to read:

"16.1.5. On a vehicle fitted with a crane for loading, unloading or other operations for which the vehicle is designed, making it impracticable to comply with all the requirements of paragraph 12., the LPD may be arranged with additional gaps where these are necessary to permit the movement or stowage of the crane."

Annex VI

PROPOSAL FOR DRAFT AMENDMENTS TO REGULATION No. 125
GRSG-97-25 adopted as follows (superseding ECE/TRANS/WP.29/GRSG/2009/20)
(see para. 37 of this report)

The modifications to the current text of the Regulation are marked in bold characters.

The list of contents, add a new reference to new figure 7, to read

7. ".....
8. Annex 4: Method for determining ...
...
Figure 6: Level work place
Figure 7: Definition of the area 'S'"

Paragraph 5.1.3., amend to read

"5.1.3. **Except as provided in 5.1.3.1 or 5.1.3.2.**, other than the obstructions created by the A pillars, the fixed or movable vent or side window division bars, outside radio aerials, rear-view mirrors and windscreen wipers, there should be no obstruction in the driver's 180° forward direct field of vision below a horizontal plane passing through V1, and above three planes through V2, one being perpendicular to the plane X-Z and declining forward 4° below the horizontal, and the other two being perpendicular to the plane Y-Z and declining 4° below the horizontal (see Annex 4, appendix, figure 4)."

Insert a new paragraph 5.1.3.2., to read:

"**5.1.3.2. An obstruction between a plane through V₂, and declined at least 1° below the horizontal and a plane through V₂ and declined 4° below the horizontal will be tolerated if the conical projection of this obstruction, starting from V₂, on an area 'S' as defined in paragraph 5.1.3.2.1. does not exceed 20 per cent of this area. The steering wheel, if adjustable, shall be placed in the normal position indicated by the manufacturer or, failing that, midway between the limits of its range(s) of adjustment.**"

Insert new paragraphs 5.1.3.2.1. and 5.1.3.2.2., to read :

"**5.1.3.2.1.**The area 'S' (see Annex 4, Appendix, figure 7) is a rectangular vertical area located in a plane perpendicular to the X coordinate 1,500 mm forward of the point V₂. The upper edge of the area 'S' is defined by a plane passing through V₂ declined forward 1° below the horizontal. The lower edge of the area 'S' is defined by a plane passing through V₂ declined forward 4° below the horizontal. The left and right edges of the area 'S' are vertical and generated from the intersection lines of the three planes declined 4° as defined in paragraph 5.1.2.2. above.

5.1.3.2.2. In the case of a windscreen extending beyond 1,500 mm forward of the point V_2 , the distance between the area 'S' and the point V_2 may be extended accordingly."

Annex 4, Appendix, insert a new figure 7, to read:

"Figure 7: Definition of the area 'S'
(paragraph 5.1.3.2.)

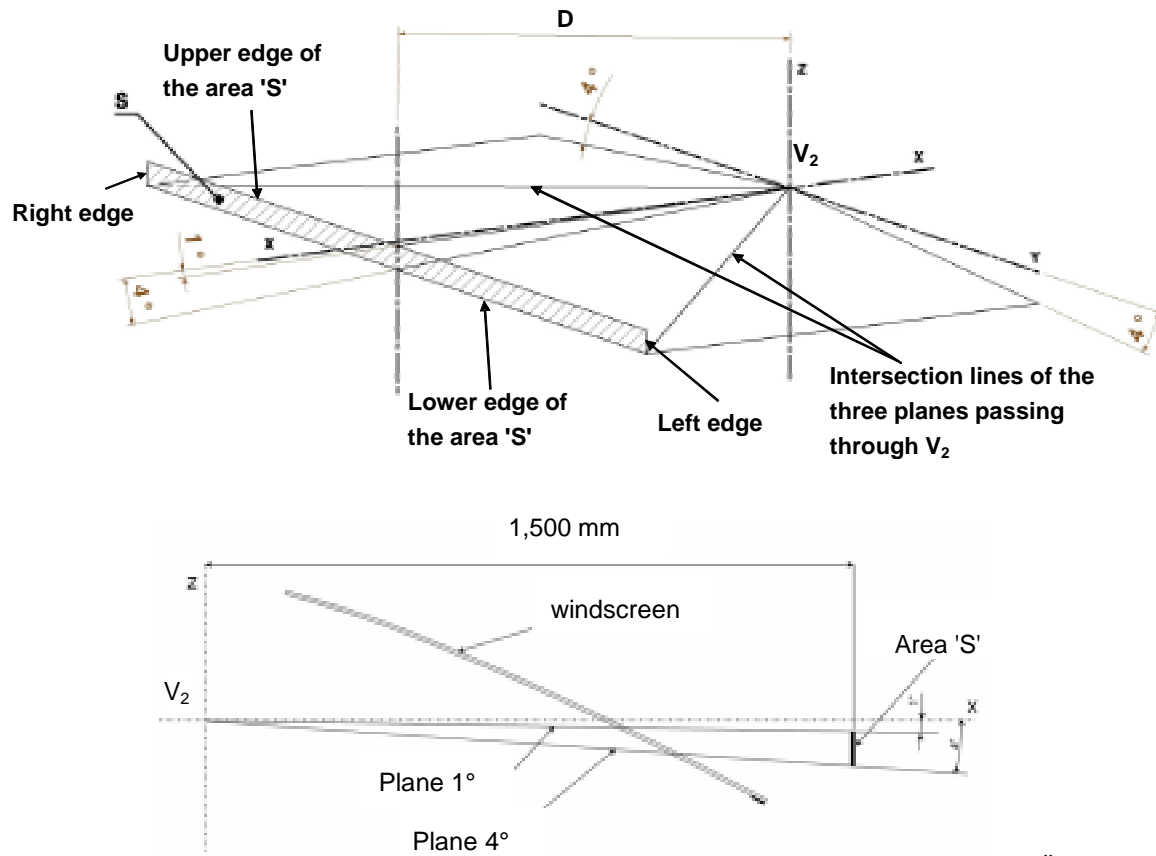

"

Annex VII

INFORMAL GROUPS OF GRSG

<u>Informal group</u>	<u>Chairman</u>	<u>Secretary</u>
Camera Monitor Systems (CMS)	Mr. H. JONGENELEN Tel: +31-79 3458268 Fax : +31-793458041 Email : hjongenelen@rdw.nl	
Service Doors, Windows and Emergency Exits in Buses and coaches(SDWEE)	Mr. J. KOWNACKI Tel:+48 22 8112510 Fax : +48 22 8114062 Email : jerzy.kownacki@its.waw.pl	OICA
gtr on motorcycle controls, tell-tales and indicators <u>1/</u>	Italy <u>1/</u>	IMMA <u>1/</u>

1/ Subject to the consent of WP.29
