



**Economic and Social  
Council**

Distr.  
GENERAL

ECE/TRANS/WP.11/2009/19  
7 September 2009

ENGLISH  
Original: ENGLISH AND RUSSIAN  
ENGLISH AND RUSSIAN ONLY

---

**ECONOMIC COMMISSION FOR EUROPE**

**INLAND TRANSPORT COMMITTEE**

Working Party on the Transport of Perishable Foodstuffs

Sixty-fifth session

Geneva, 27-30 October 2009

Items 6 of the provisional agenda

**ATP HANDBOOK**

Proposed addition to Annex 1, Appendix 2 of the ATP Handbook with layouts for the placement of temperature measuring devices inside and outside of transport equipment – tanks with one, three and more compartments during tests aimed at determining the overall coefficient of heat transfer (K coefficient)\*

Transmitted by the Government of the Russian Federation

**SUMMARY**

**Executive summary:** Subparagraphs (a) and (b) of Annex 1, Appendix 2, paragraph 21 of ATP contain the textual description of the requirements for the placement of air temperature measuring devices inside and outside of transport equipment – tanks (further referred to as “tanks”) with one and more compartments during tests aimed at determining the K coefficient.

---

\* The present document is submitted in accordance with the Programme of Work for 2008-2012 of the Inland Transport Committee (ECE/TRANS/2008/11, Item 2.11 (f)) which calls for the “Elaboration of an ATP Handbook”.

The absence in the ATP Handbook of graphic illustrations in the form of layouts for the placement of air temperature measuring devices inside and outside of tanks with one and more compartments during tests aimed at determining the K coefficient complicates the perception of the textual descriptions given in subparagraphs (a) and (b) of Annex 1, Appendix 2, paragraph 21 of ATP. As a result they may be misunderstood or misinterpreted.

**Action to be taken:** Supplement Annex 1, Appendix 2 of the ATP Handbook with layouts for the placement of air temperature measuring devices inside and outside of tanks with one, three and more compartments during tests aimed at determining the K coefficient.

**Related documents:** None.

### **Introduction**

1. At the sixty-fourth session of the Working Party on the Transport of Perishable Foodstuffs (WP.11), the Russian Federation presented informal document No. 4 with a proposal to supplement the ATP Handbook with layouts demonstrating the placement of air temperature measuring devices inside and outside of tanks with one and three compartments during tests of such tanks aimed at determining the K coefficient.

2. At the sixty-fourth session, the WP.11 examined the proposal of the Russian Federation, adopted it in principle and asked the Russian Federation to present at the WP.11's sixty-fifth session an official document taking into account the following remarks made during the discussions at the sixty-fourth session:

- Provide for tanks with more than three compartments and reflect it in the graphical illustrations;
- Translate the captions to the illustrations into English.

3. The Russian Federation has complied with the Working Party's request and submits for consideration the corresponding official documents.

### **Proposal**

4. Supplement the current version of the ATP Handbook with comments to subparagraphs (a) and (b) of Annex 1, Appendix 2, paragraph 21 of ATP as follows:

*Comment to subparagraph (a) of Annex 1, Appendix 2, paragraph 21:*

*The layout of the placement of air temperature measuring devices inside and outside tanks with one compartment is shown in figure 1;*

*Comment to subparagraph (b) of Annex 1, Appendix 2, paragraph 21:*

*The layout of the placement of air temperature measuring devices inside and outside tanks with three or more compartments is shown in figure 2.*

5. The respective figures are shown below.
6. Change the numbering of subsequent figures in the ATP Handbook.

### **Justification**

7. In the Russian Federation's opinion it is crucial to ensure the harmonized observance of ATP requirements by all Contracting Parties. The specialists at the testing facilities of Contracting Parties must be fully aware of all provisions regarding the testing of tanks with one, three and more compartments aimed at determining the K coefficient.

8. After the introduction of the additions proposed by the Russian Federation to the ATP Handbook no questions should remain as to the placement of air temperature measuring devices inside and outside of tanks with one, three and more compartments during tests of such tanks aimed at determining the K coefficient.

### **Simplification**

9. The introduction of the additions proposed by the Russian Federation will simplify the understanding of the requirements regarding the placement of air temperature measuring devices inside and outside of tanks with one, three and more compartments, as well as the training of specialists responsible for conducting tests to ensure the compliance of tanks with ATP requirements.

### **Costs**

10. None.

### **Feasibility**

11. It is expected that the proposed additions will enable the specialists of ATP testing facilities to achieve an unambiguous interpretation of the ATP's requirements regarding the placement of air temperature measuring devices inside and outside of tanks with one, three and more compartments during tests of tanks with one, three and more compartments aimed at determining the K coefficient.

### **Enforceability**

12. No problem with enforceability is expected.

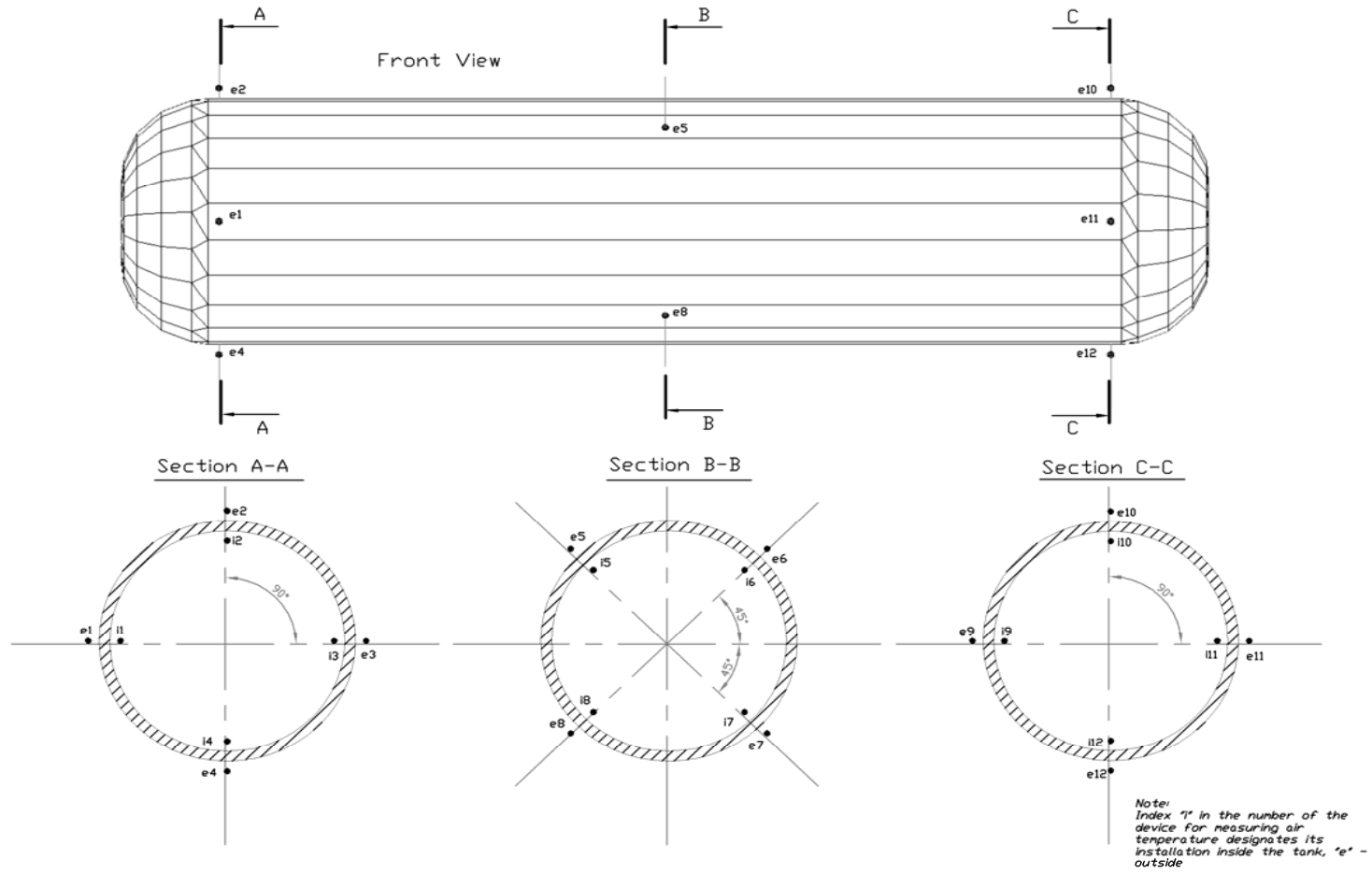

Fig. 1

Scheme of accommodation of devices for measuring air temperature inside and outside the tank with one compartment

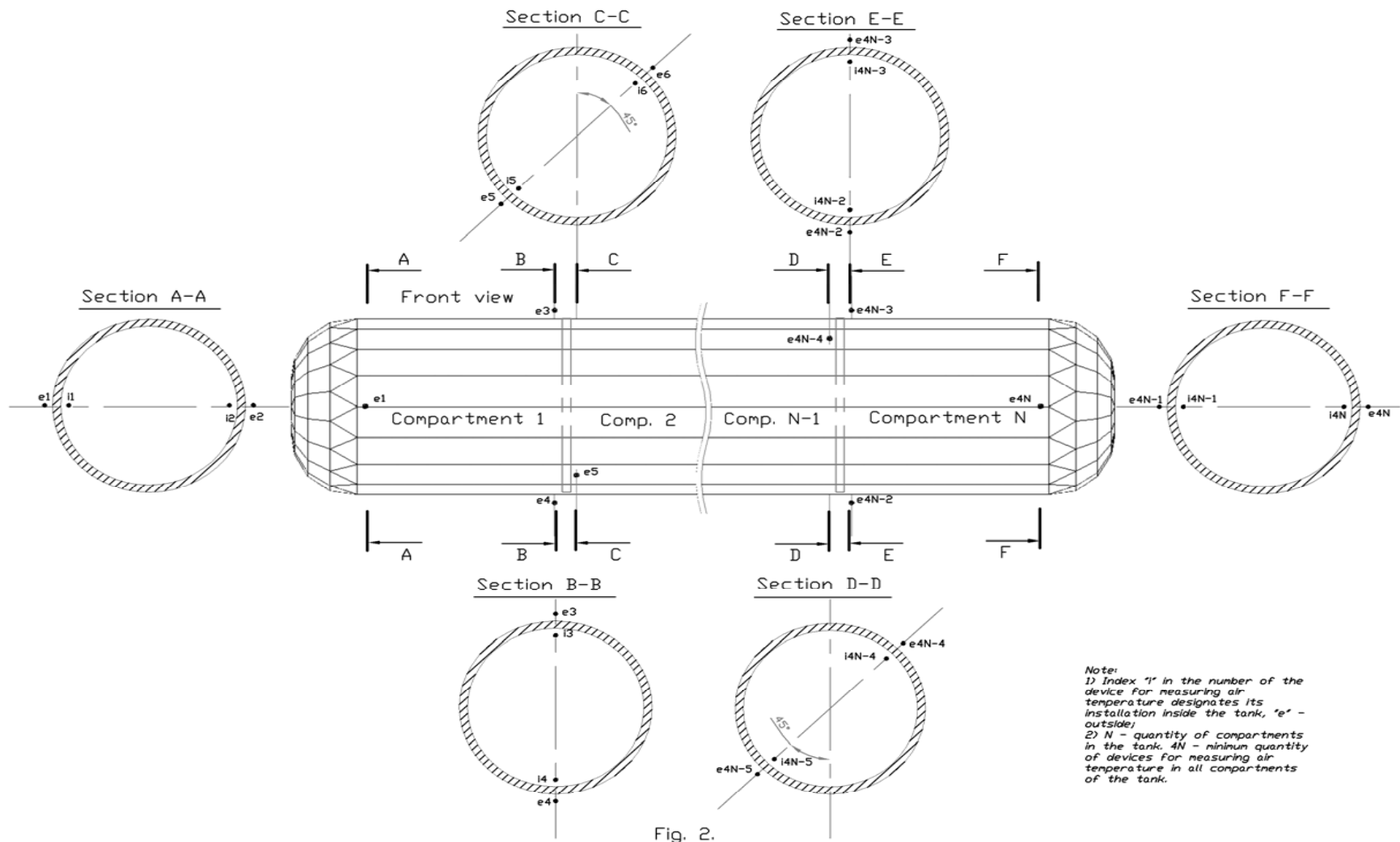

Fig. 2.

Scheme of accommodation of devices for measuring air temperature inside and outside the tank with three and more compart.

Note:  
 1) Index '1' in the number of the device for measuring air temperature designates its installation inside the tank, 'e' - outside;  
 2) N - quantity of compartments in the tank. 4N - minimum quantity of devices for measuring air temperature in all compartments of the tank.