



**Economic and Social  
Council**

Distr.  
GENERAL

ECE/TRANS/WP.29/GRE/2009/13  
16 January 2009

Original: ENGLISH  
ENGLISH AND FRENCH ONLY

---

**ECONOMIC COMMISSION FOR EUROPE**

**INLAND TRANSPORT COMMITTEE**

World Forum for Harmonization of Vehicle Regulations

Working Party on Lighting and Light-Signalling

Sixty-first session

Geneva, 30 March - 3 April 2009

Item 3(a) of the provisional agenda

**REGULATION No. 37**  
**(Filament lamps)**

**Proposal for Supplement 34 to the 03 series of amendments**

**Submitted by the expert from the Working Party "Brussels 1952" \*/**

The text reproduced below was prepared by the expert from the Working Party "Brussels 1952" (GTB) in order to introduce into Regulation No. 37 the provisions for a new category of filament light source PSX26W. The proposal is based on the current text of the Regulation including draft Supplement 33 to the 03 series of amendments. The modifications to the current text of Regulation No. 37 are marked in bold characters.

---

\*/ In accordance with the programme of work of the Inland Transport Committee for 2006-2010 (ECE/TRANS/166/Add.1, programme activity 02.4), the World Forum will develop, harmonize and update Regulations in order to enhance performance of vehicles. The present document is submitted in conformity with that mandate.

A. PROPOSAL

Annex 1,

The list of categories of filament lamps, grouped, and their sheets, amend to read:

"

Group 1

Without general restrictions:

<u>Category</u>		<u>Sheet number(s)</u>
H1		H1/1 to 3
...		
PSX24W	<u>**/</u>	P24W/1 to 3
<b>PSX26W</b>	<u>**/</u>	<b>PSX26W1 to 3</b>
PX24W	<u>**/</u>	P24W/1 to 3
S2		S1/S2/1 to 2
S3		S3/1

"

The list of sheets for filament lamps and their sequence, amend to read:

"

<u>Sheet number(s)</u>
C21W/1 to 2
...
PR27/7W/1
<b>PSX26W/1 to 3</b>
PY21W/1
...

"

Insert new sheets PSX26W/1 to 3, between sheet PR27/7W/1 and sheet PY21W/1, to read (see next pages):

CATEGORY PSX26W

Sheet PSX26W/1

The drawings are intended only to illustrate the essential dimensions (in mm) of the filament lamp

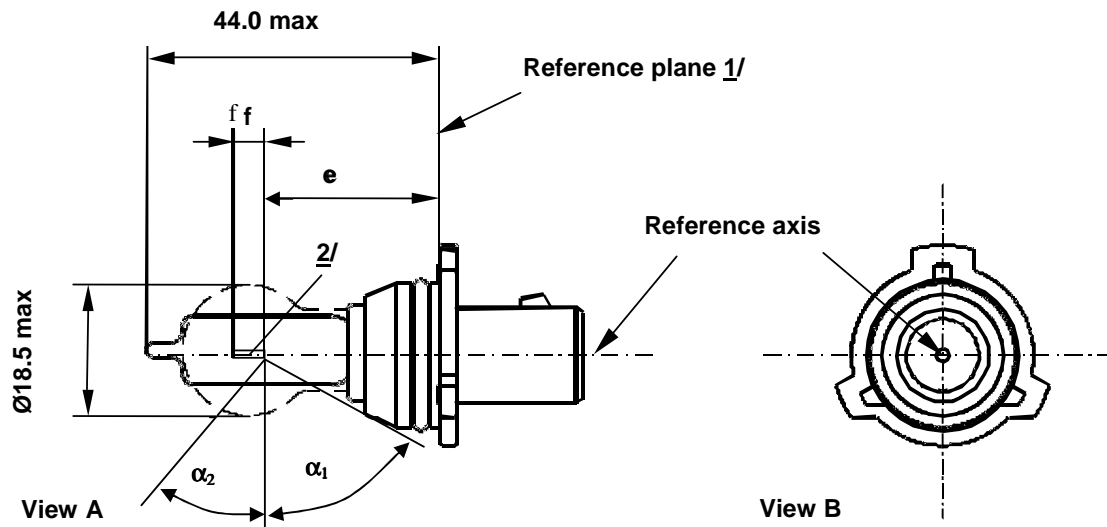

Figure 1 – Main drawing

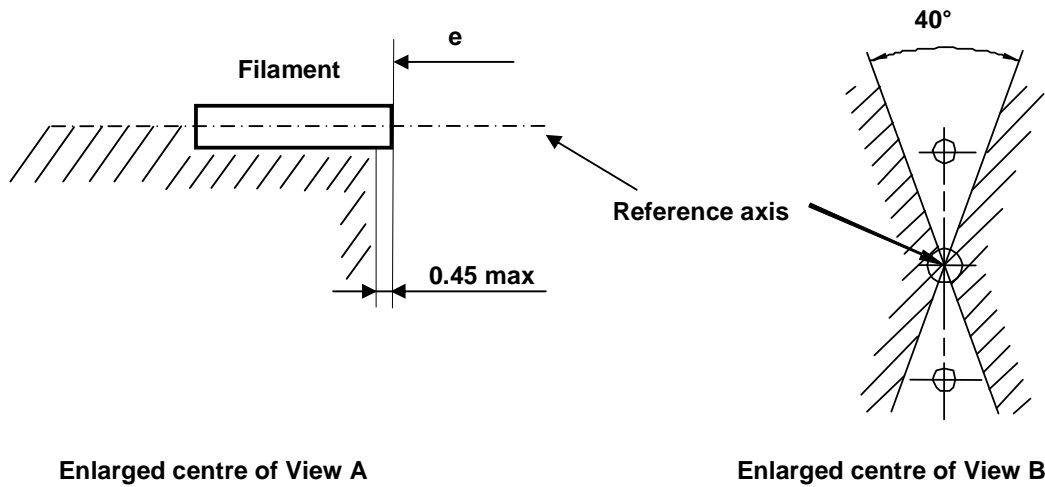

Figure 2 – Metal free zone 3/

- 1/ The reference plane is defined by the meeting points of the cap-holder fit.
- 2/ No actual filament diameter restrictions apply but the objective is  $d_{max} = 1.1$  mm.
- 3/ No opaque parts other than filament turns shall be located in the shaded area indicated in Figure 2. This applies to the rotational body within the angles  $\alpha_1 + \alpha_2$ .

## CATEGORY PSX26W

## Sheet PSX26W/2

Dimensions in mm		Filament lamps of normal production		Standard filament lamp
e	<u>5/</u>	24.0	<u>4/</u>	24.0 ± 0.25
f	<u>5/</u>	4.2	<u>4/</u>	4.2 ± 0.25
α1	6/	35.0° min.		35.0° min.
α2	6/	58.0° min.		58.0° min.
Cap PG18.5d-3		in accordance with IEC Publication 60061 (sheet 7004-147-1)		
ELECTRICAL AND PHOTOMETRIC CHARACTERISTICS				
Rated values	Voltage	V	12	12
	Wattage	W	26	26
Test voltage		V	13.5	13.5
Objective values	Wattage	W	26 max.	26 max.
	Luminous flux	lm	500	
		±	+10% / -10%	
Reference luminous flux at approximately 13.2V				465 lm
Reference luminous flux at approximately 13.5V				500 lm

- 4/ To be checked by means of a "Box-System"; sheet PSX26W/3.
- 5/ The ends of the filament are defined as the points where, when the viewing direction is perpendicular to the plane through the filament lead-in wires, the projection of the outside of the end turns crosses the filament axis.
- 6/ No part of the cap beyond the reference plane shall interfere with angle α2 as shown in Figure 1 on sheet PSX26W/1. The bulb shall be optically distortion free within the angles α1+ α2. These requirements apply to the whole bulb circumference.

CATEGORY PSX26W

Sheet PSX26W/3

Screen projection requirements

This test is used to determine, by checking whether the filament is correctly positioned relative to the reference axis and reference plane, whether a filament lamp complies with the requirements.

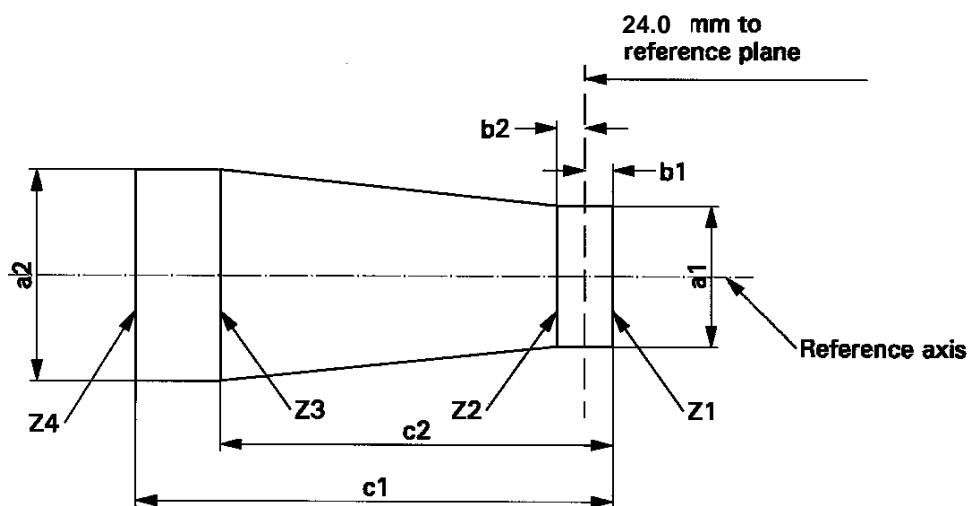

	a1	a2	b1,b2	c1	c2
Filament lamps of normal production	1.7	1.7	0.30	5.0	4.0
Standard filament lamps	1.5	1.5	0.25	4.7	4.0

The filament position is checked in two mutually perpendicular planes, one of them being the plane through the lead-in wires.

The ends of the filament as defined on sheet PSX26W/2, note 4/, shall lie between  $Z_1$  and  $Z_2$  and between the lines  $Z_3$  and  $Z_4$ .

The filament shall lie entirely within the limits shown.

B. JUSTIFICATION

This new category PSX26W is intended for combined functions which require dimming, such as DRL / front position lamp combinations, and for front fog applications.

----