



**Economic and Social
Council**

Distr.
GENERAL

ECE/TRANS/WP.29/2008/66
10 April 2008

ENGLISH
Original: ENGLISH AND FRENCH

ECONOMIC COMMISSION FOR EUROPE

INLAND TRANSPORT COMMITTEE

World Forum for Harmonization of Vehicle Regulations

One-hundred-and-forty-fifth session
Geneva, 24-27 June 2008
Item 4.2.10 of the provisional agenda

1958 AGREEMENT

Consideration of draft amendments to existing Regulations

Proposal for Supplement 6 to Regulation No. 106
(Tyres for agricultural vehicles)

Submitted by the Working Party on Running Gear (GRRF) */

The text reproduced below was adopted by GRRF at its sixty-third session. It is based on ECE/TRANS/WP.29/GRRF/2008/8, not amended. It is submitted to WP.29 and AC.1 for consideration (ECE/TRANS/WP.29/GRRF/63, para. 28).

*/ In accordance with the programme of work of the Inland Transport Committee for 2006-2010 (ECE/TRANS/166/Add.1, programme activity 02.4), the World Forum will develop, harmonize and update Regulations in order to enhance performance of vehicles. The present document is submitted in conformity with that mandate.

Paragraph 3.1.11., amend to read:

"3.1.11. the inscription "...bar MAX." (or "... kPa MAX") inside the ..."

Paragraph 4.1.12., amend to read:

"4.1.12. The inflation pressure (bar or kPa) for measurements."

Annex 8, paragraph 2.1.1., amend to read:

"2.1.1. ... shall be lower than 6 bar (600 kPa) or higher than 10 bar (1000 kPa);"

Annex 11, replace the existing pictogram by the following:

"

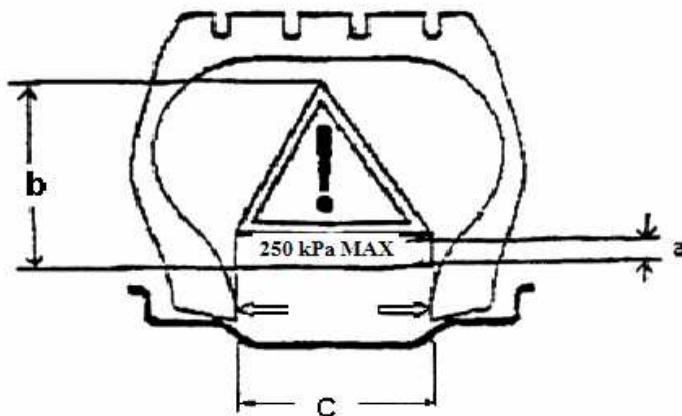

"
