



**Economic and Social
Council**

Distr.
GENERAL

ECE/TRANS/WP.29/2008/54
3 January 2008

Original: ENGLISH

ECONOMIC COMMISSION FOR EUROPE

INLAND TRANSPORT COMMITTEE

World Forum for Harmonization of Vehicle Regulations

One-hundred-and-forty-fourth session
Geneva, 11-14 March 2008
Item 14.3. of the provisional agenda

1998 AGREEMENT

CONSIDERATION AND VOTE OF DRAFT GLOBAL TECHNICAL REGULATIONS
AND/OR DRAFT AMENDMENTS TO ESTABLISHED GLOBAL TECHNICAL
REGULATIONS

Proposal for a draft global technical regulation concerning head restraints

Draft global technical regulation concerning head restraints

Submitted by the Working Party on Passive Safety */

The text reproduced below was adopted by the Working Party on Passive Safety (GRSP) at its forty-second session (ECE/TRANS/WP.29/GRSP/42, para. 19). It is submitted to the Executive Committee of the 1998 Agreement (AC.3) with the recommendation to establish it in the Global Registry by vote.

*/ In accordance with the programme of work of the Inland Transport Committee for 2006-2010 (ECE/TRANS/166/Add.1, programme activity 02.4), the World Forum will develop, harmonize and update Regulations in order to enhance performance of vehicles. The present document is submitted in conformity with that mandate.

A. STATEMENT OF TECHNICAL RATIONALE AND JUSTIFICATION

1. THE SAFETY CONCERN

1. Whiplash injuries are a set of common symptoms that occur in motor vehicle crashes and involve the soft tissues of the head, neck and spine. Symptoms of pain in the head, neck, shoulders, and arms may be present along with damage to muscles, ligaments and vertebrae, but in many cases lesions are not evident. The onset of symptoms may be delayed and may only last a few hours; however, in some cases, effects of the injury may last for years or even be permanent. The relatively short-term symptoms are associated with muscle and ligament trauma, while the long-term ones are associated with nerve damage.

2. Whiplash injuries are a world-wide problem. In the European Community, there are over 1 million total whiplash injuries a year and the cost of these injuries in the EC is estimated to be €5 to €10 billion per annum and rising (Kroonenburg and Wisman, 1999; EEVC Report No 167). In the United Kingdom (UK) the cost of long-term injuries alone has been reported as £3 billion. (UK Cost Benefit Analysis: Enhanced Geometric Requirements, EEVC Report, September 2007, <http://www.eevc.org>) In the Republic of Korea, rear end collisions account for 34 per cent of all car to car collisions and cause 31 per cent of fatalities and 37 per cent of injuries. Additionally, rear impact collisions cause 260,000 neck injuries in 2002 or 57 per cent of all neck injuries in car to car collisions. In Japan, rear impacts account for 31 per cent of collisions resulting in bodily injury. Of these crashes, 91 per cent of the injuries or 309,939 are minor neck injuries. In 2004, among rear impact collisions resulting in bodily injury, 81.7 per cent of male and 88 per cent of female drivers of the impacted vehicles sustained minor neck injuries.

3. Based on National Analysis Sampling System (NASS) data, the United States of America estimated that between 1988 and 1996, 805,581 whiplash injuries^{1/} occurred annually in crashes involving passenger cars and LTVs (light trucks, multipurpose passenger vehicles, and vans). Of these whiplash injuries, 272,464 occurred as a result of rear impacts. For rear impact crashes, the average cost of whiplash injuries in 2002 dollars is \$9,994 (which includes \$6,843 in economic costs and \$3,151 in quality of life impacts, but not property damage), resulting in a total annual cost of approximately \$2.7 billion. Although the front outboard seat occupants sustain most of these injuries, whiplash is an issue for rear seat passengers as well. During the same time frame, an estimated 5,440 whiplash injuries were reported annually for occupants of rear outboard seating positions (HR-1-8).

2. UNDERSTANDING WHIPLASH

4. Although whiplash injuries can occur in any kind of crash, an occupant's chances of sustaining this type of injury are greatest in rear-end collisions. When a vehicle is struck from behind, typically several things occur in quick succession to an occupant of that vehicle. First, from the occupant's frame of reference, the back of the seat moves forward into his or her torso, straightening the spine and forcing the head to rise vertically. Second, as the seat pushes the occupant's body forward, the unrestrained head tends to lag behind. This causes the neck to

^{1/} Non-contact Abbreviated Injury Scale (AIS) 1 neck.

change shape, first taking on an S-shape and then bending backward. Third, the forces on the neck accelerate the head, which catches up with - and, depending on the seat back stiffness and if the occupant is using a shoulder belt, passes - the restrained torso. This motion of the head and neck, which is like the lash of a whip, gives the resulting neck injuries their popular name.

3. CURRENT KNOWLEDGE.

5. There are many hypotheses as to the mechanisms of whiplash injuries. Despite a lack of consensus with respect to whiplash injury biomechanics, there is research indicating that reduced backset will result in reduced risk of whiplash injury. For example, one study of Volvo vehicles reported that, when vehicle occupants involved in rear crashes had their heads against the head restraint (an equivalent to 0 mm backset) during impact, no whiplash injury occurred.^{2/} By contrast, another study showed significant increase in injury and duration of symptoms when occupant's head was more than 100 mm away from the head restraint at the time of the rear impact.^{3/}

6. In addition, the persistence of whiplash injuries in the current fleet of vehicles indicates that the existing height is not sufficient to prevent excessive movement of the head and neck relative to the torso for some people. Specifically, the head restraints do not effectively limit rearward movement of the head of a person at least as tall as the average occupant. Biomechanically, head restraints that reach at least up to the centre of gravity of the head would better prevent whiplash injuries, because the head restraint can more effectively limit the movement of the head and neck.

7. In a recent report from the Insurance Institute for Highway Safety (IIHS), Farmer, Wells, and Lund examined automobile insurance claims to determine the rates of neck injuries in rear end crashes for vehicles with the improved geometric fit of head restraints (reduced backset and increased head restraint height).^{4/} Their data indicate that these improved head restraints are reducing the risk of whiplash injury. Specifically, there was an 18 per cent reduction in injury claims. Similarly, United States of America computer generated models have shown that the reduction of the backset and an increase in the height of the head restraint reduces the level of neck loading and relative head-to-torso motion that may be related to the incidence of whiplash injuries.^{5/}

8. With respect to impact speeds, research and injury rate data indicate that whiplash may occur as a result of head and neck movements insufficient to cause hyperextension. Staged low speed impacts indicate that mild whiplash symptoms can occur without a person's head exceeding the normal range of motion. This means that our previous focus on preventing neck

^{2/} Jakobsson et al., "Analysis of Head and Neck Responses in Rear End Impacts - A New Human-Like Model". Volvo Car Corporation Safety Report (1994).

^{3/} Olsson et al., An In-depth Study of Neck Injuries in Rear-end Collisions. International IRCOBI Conference, pp 269-280 (1990).

^{4/} Farmer, Charles, Wells, JoAnn, Lund, Adrian, "Effects of Head Restraint and Seat Redesign on Neck Injury Risk in Rear -End Crashes", Insurance Institute For Highway Safety, October 2002.

^{5/} "Effect of Head Restraint Position on Neck Injury in Rear Impact", World Congress of Whiplash-Associated Disorders (1999), Vancouver, British Columbia.

hyperextension is insufficient to adequately protect all rear impact victims from risks of whiplash injuries. Instead, to effectively prevent whiplash, the head restraint must control smaller amounts of rapid head and neck movement relative to the torso.

9. In sum, in light of recent evidence that whiplash may also be caused by smaller amounts of head and neck movements relative to the torso, and that reduced backset and increased height of head restraints help to better control these head and neck movements, we agreed to recommend that head restraints should be of sufficient height and positioned closer to the occupant's head in order to be more effective in preventing whiplash.

4. PROCEDURAL BACKGROUND

10. During the one-hundred-twenty-sixth session of the World Forum for Harmonization of Vehicle Regulation (WP.29) of March 2002, the Executive Committee of the 1998 Agreement (AC.3) adopted a Program of Work, which includes the development of a global technical regulation (gtr) to address neck injuries in crashes. The United States of America volunteered to lead the group's efforts and develop a document detailing the recommended requirements for the gtr. The United States of America presented an informal document (WP.29-134-12) in November 2004 proposing the work and highlighting the relevant issues to be addressed in the gtr. This proposal was adopted at the March 2005 session of WP.29 (TRANS/WP.29/AC.3/13). The Working Party on Passive Safety (GRSP) developed the head restraint gtr. During the course of development, GRSP sought and received guidance from AC.3 on some issues (WP.29-142-23 and WP.29-143-23rev.1). At its December 2007 session, GRSP concluded its work and agreed to recommend to the Executive Committee the establishment of this gtr into the Global Registry.

5. GLOBAL TECHNICAL REGULATION REQUIREMENTS

5.1. Applicability

11. The application of a head restraint gtr uses the revised vehicle classification and definitions of Special Resolution No. 1.

12. There has been extensive discussion of the applicability of this gtr. The application of United States of America Federal Motor Vehicle Safety Standard (FMVSS) No. 202 is different to UNECE Regulation No. 17. FMVSS No. 202 requires head restraints in all front outboard seating positions and regulates head restraints optionally installed in the rear outboard seating positions for vehicles up to 4,536 kg. UNECE Regulation No. 17 requires head restraints in all front outboard seating positions of vehicles of category M₁ ^{6/}, in all front outboard seating positions of vehicles of category M₂ ^{6/} with a maximum gross vehicle mass (GVM) not exceeding 3,500 kg, and all front outboard seating positions of vehicles of category N₁ ^{6/} and allows for optional type approval of head restraints optionally installed in other seating positions, or in other vehicles.

^{6/} As defined in Annex 7 to the Consolidated Regulation on the Construction of Vehicles (R.E.3) (document TRANS/WP.29/78/Amend.2 at last amended by Amend. 4).

13. It was proposed that the gtr, as it pertains to front outboard seats, should apply to vehicles up to 4,536 kg. The United States of America presented justification (HR-4-4), developed in 1989, when the applicability of their regulation was increased to 4,536 kg. By extending the applicability from passenger cars to include trucks, buses, and multipurpose passenger vehicles, there was an estimated reduction of 510 to 870 injuries at an average cost of \$29.45 per vehicle (1989 dollars). The United States of America presented further analysis (HR-10-3) that showed an additional 348 injuries reduced when the requirements of the gtr are applied to Category 2 vehicles (light trucks) between the range of 3,500 – 4,500 kg GVM. Japan presented 2004 data (HR-4-10) showing the breakdown, by vehicle weight, of crashes resulting in whiplash injuries. They show 7,173 (2.3 per cent) rear impacts involving vehicles with a GVM over 3,500 kg that resulted in bodily injury.

14. There is consensus to recommend a wide application in the gtr. Specifically, that head restraints in all front outboard seating positions for Category 1-1 ^{7/} vehicles, for Category 1-2 ^{7/} vehicles with a gross vehicle mass of up to 4,500 kg, and for Category 2 ^{7/} vehicles with a gross vehicle mass up to 4,500 kg.

15. Given the variability in target population in different jurisdictions, such as the differing data from the United States of America and Japan, it was recommended that the gtr should be drafted to have a wide application to vehicles, to maximize the ability of jurisdictions to effectively address regional differences in whiplash crash characteristics. The gtr would establish that if a jurisdiction determines that its domestic regulatory scheme is such that full applicability is inappropriate, it may limit domestic regulation to certain vehicle categories or mass limits. The jurisdiction could also decide to phase-in the requirements for certain vehicles. A footnote was added to the gtr text to make it clear that jurisdictions can decide to limit the applicability of the regulation. This approach recognizes that niche vehicles that are unique to a jurisdiction would best be addressed by that jurisdiction, without affecting the ability or need for other jurisdictions to regulate the vehicles. When a Contracting Party proposes to adopt the gtr into its domestic regulations, it is expected that the Contracting Party will provide reasonable justification concerning the limitation of the application of the standard.

5.2. Purpose

16. The informal group was unable to define a purpose that correlated with injury since the mechanisms are not well understood. Therefore, more general text was developed from the definition of head restraints. The recommended text for the purpose is: "This gtr specifies requirements for head restraints to reduce the frequency and severity of injuries caused by rearward displacement of the head."

^{7/} As defined in the Special Resolution No. 1 concerning the PTO Common Definitions of Vehicle Categories, Masses and Dimensions (document TRANS/WP.29/1045).

5.3. General Requirements

17. Due to the high occupancy rates of front outboard seats, it is recommended that they are equipped with head restraints that meet the requirements of the gtr. These requirements include dimensional and static evaluations, and may include dynamic evaluations.

18. For all other seating positions ^{8/} it is recommended that the installation of head restraints is optional, but if installed these head restraints shall meet most of the requirements of the gtr. ^{9/} Fewer rear seat occupants are exposed to risks in rear impacts because rear seats are much less likely to be occupied than front seats. An analysis of the distribution of occupants by seating position for all vehicle types in 2001 to 2003 United States of America National Automotive Sampling System (NASS) shows that 10 per cent of all occupants sit in the second (or higher) row of outboard seats. It is noted that children and small adults derive less benefit from higher head restraints because their head centre of gravity often does not reach the height of 750 mm above the H-point. Therefore, if these data are further refined to include only occupants who are 13 years or older, the relevant percentage is reduced to approximately 5.1. ^{10/} This conclusion about rear seat occupancy is further supported by United States of America data (HR-1-3), which indicate that out of a total of 272,464 annually occurring whiplash injuries, approximately 21,429 (7.8 per cent) occur to the rear seat occupants. In summary, only a small percentage of occupants who are tall enough to benefit from higher head restraints sit in rear outboard seating positions. These percentages are even smaller for front centre and rear centre seating positions.

5.4. Dynamic Test

19. Ideally, the degree of whiplash injury should be evaluated based on dynamic testing that represents "real world" crashes; that is, based on a vehicle acceleration that occurs in real crashes and a dummy with high biofidelity that reflects the injury mechanism, and injury indices. However, at present, there is still not a sufficient amount of medical data to accurately define the injury mechanism; therefore appropriate injury indices have not been developed. In the interim, AC.3 recommends a dynamic testing option, as an alternative to the static performance requirements in this gtr. A dynamic test option was proposed primarily for two reasons. First, a dynamic test better represents "real-world" injury-causing events and thus is expected to produce greater assurance than the static measurement option of effective real world performance. Second, as explained below, it is believed that a dynamic test will help to encourage continued development and use of "dynamic" head restraint systems ^{11/} because the test is designed to allow a manufacturer the flexibility necessary to offer innovative dynamic head restraint designs.

^{8/} The informal group did not reach agreement on a definition of seating position, and therefore this is left to each Contracting Party or regional economic integration organization.

^{9/} Head restraints at seating positions other than front outboard are not required to meet the backset requirements as explained later in this document.

^{10/} We further note that approximately 2 per cent of rear seat occupants sit in the centre seating positions.

^{11/} For the purposes of this gtr, "dynamic head restraint system" means a system that is intended to reduce the occupant's injury by moving the head restraint forward during a crash or when the crash is about to occur ("pre-active" systems). The head restraint movement may be obtained by "active" systems whereby the head restraint is activated automatically (e.g. a pyrotechnic head

20. Dynamic head restraint systems deploy in the event of a collision to minimize the potential for whiplash. During the normal vehicle operation, the dynamic head restraint system is "retracted." Because a dynamic head restraint system requires a certain range of motion to work effectively, an "undeployed" dynamic head restraint system might not meet the static performance requirements, in particular the backset measurement requirements.

21. Although the dynamic compliance option is intended to ensure that the gtr encourages continuing development of dynamic head restraint systems, the option is left to the manufacturer and is available to both dynamic and conventional, or "static," head restraint systems. That is, both types of head restraints can be evaluated to either static requirements or the dynamic test option.

22. The United States of America currently has the only regulation with a dynamic testing option. Under the United States of America dynamic option, the entire vehicle is exposed to a half-sine deceleration pulse with a target of 8.8 g peak and 88 ms duration. The 50th percentile male Hybrid III dummy in each seat must have a maximum head-to-torso rotation of less than 12 degrees and a HIC15 (Head Injury Criteria) of less than 500.

23. In this gtr under direction from AC.3, when the dynamic test procedure with Hybrid III is allowed the maximum relative head-to-torso rotation value is limited to 12 degrees with the 50th percentile male dummy in all seats, with the head restraint adjusted vertically midway between the lowest and the highest position of adjustment. The head restraint is to be positioned at the middle position of vertical adjustment because there are concerns with the effects of this gtr on dynamic head restraint systems. As previously stated, there is a need to ensure that the dynamic test option encourages continuing development of dynamic head restraint systems. As discussed below, research indicates that current head restraint systems can meet the head-to-torso rotation limit in this gtr when the head restraint is adjusted midway between the lowest and the highest position of adjustment.

24. Using published data of low speed rear impact testing of original equipment manufacturer (OEM) seats with Hybrid III 50th percentile male dummies (Viano, D., Davidsson, J., "Neck Displacement of Volunteers, BioRID P3 and Hybrid III in Rear Impacts: Implications to Whiplash Assessment by a Neck Displacement Criterion (ND)," Traffic Injury Prevention, 3:1005-116, 2002), and information on whiplash injuries sustained by occupants of these seats, a logistic regression was used to develop a probability of whiplash injury as a function of dummy head-to-torso rotation. The function is shown in Figure 1.

restraint system that utilizes a gas discharge to deploy head restraints) or "reactive", (using the force generated when the occupant loads the seat at the time of rear-end collision) or by some other driving force. The definition can be determined by each Contracting Party or regional economic integration organization.

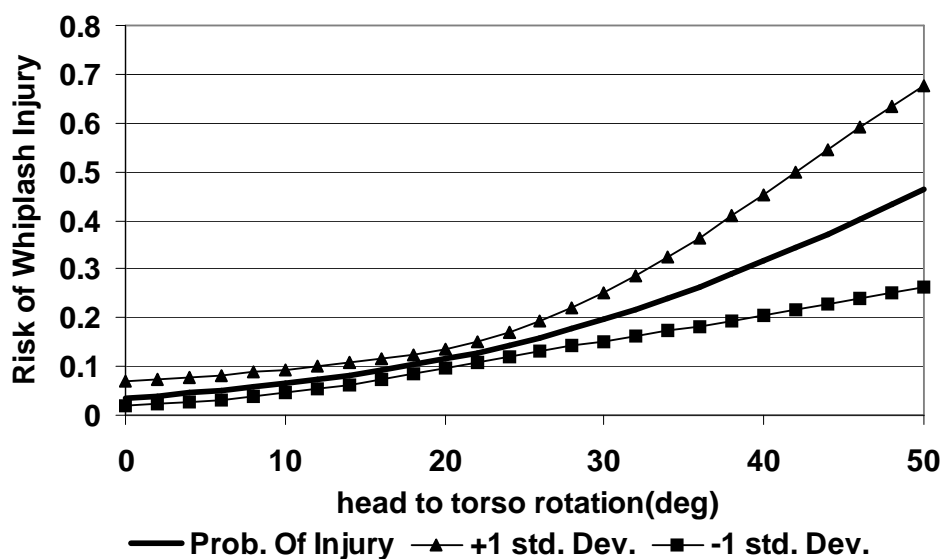

Figure 1
Risk of Whiplash Injury versus head-to-torso rotation
on the Hybrid III 50th percentile male dummy

25. A 12-degree head-to-torso rotation corresponds to a 7.3 per cent probability of whiplash. This criterion was selected to ensure adequate protection for occupants who range in stature from shorter females up to and including taller males, for all seats. In evaluating the head-to-torso rotation limit, it was noted that in the past there has not been a consensus among the biomechanics community on how best to measure the potential for whiplash injury. Presently, the relative head-to-torso rotation is the best criterion available, and will assure early head restraint interaction. The goal in selecting performance criterion limits for the dynamic compliance option was to provide a level of safety similar to that provided by the static requirements. However, given the differences in the basic nature of the test requirements, it is not believed to be possible to provide one-to-one correspondence between the two sets of tests. Thus, a particular vehicle may be able to pass one test but not the other.

26. The United States of America performed sled testing as specified in the dynamic compliance option on a specially designed seat to explore how various seat characteristics affect relative head rotation and other dummy injury measures.^{12/} An OEM seat with an adjustable head restraint was modified by removing the original recliner mechanism and replacing it with a pin joint free to rotate. The seat back was also reinforced with steel channels that provided the attachment points for a spring and damper system on each side of the seat. Seat back strength in the rearward direction was modified by changing the springs and or their location of attachment relative to the hinge joint. In addition to seat back strength, sensitivity analyses to head restraint attachment strength and seat back upholstery compliance were also performed. Tests were performed with belted 5th percentile female, 50th percentile male and 95th percentile male Hybrid III dummies.

^{12/} For full details of these tests, please see Docket No. NHTSA-2000-8570-57, 58, 59.

27. The head restraint height was either 750 mm or 800 mm and the backset was always 50 mm as measured by the HRMD. However, the majority of tests (20 tests) were performed with the 50th percentile male dummy with a 750 mm high head restraint. For all seat back parameters tested with this configuration of dummy and head restraint height, the range of relative head-to-torso rotation was 6 to 16 degrees. HIC15 was measured for half of these tests and ranged from 40 to 75. Nearly half of the seat configurations (9 of 20) met the 12-degree limit placed on the dynamic compliance option for a head restraint in the lowest adjustment position (750 mm). In general, the smallest relative rotations were seen for the baseline seat back strength ^{13/} and non-rotating seat backs irrespective of the other seat/head restraint parameters. From these tests, it was concluded that the head rotation and HIC limits selected can be met with typical seat back/head restraint designs when appropriate consideration is given to design in terms of height, backset and strength of head restraint attachment.

28. In a separate set of tests, the United States of America subjected a MY 2000 Saab 9–3 seat to the sled pulse of the dynamic test option. A 95th percentile male Hybrid III dummy occupied the seat. The Saab 9–3 has a dynamic head restraint system, and the head restraint was set to its highest position of adjustment. The maximum head-to-torso rotation was 9 degrees. Viano and Davidsson (Viano, D., Davidsson, J., "Neck Displacement of Volunteers, BioRID P3 and Hybrid III in Rear Impacts: Implications to Whiplash Assessment by a Neck Displacement Criterion (ND)," *Traffic Injury Prevention*, 3:1005-116, 2002) also sled tested a 9–3 head restraint at a slightly lower, 16 km/h ΔV , with the seat occupied by a 50th percentile male Hybrid III dummy. With the head restraint in the up position, the relative head rotation was measured at 6.5 degrees. With the head restraint midway between the lowest and the highest position of adjustment, the relative head rotation was 10 degrees at 23.5 km/h ΔV . It is assumed that this configuration would yield an even smaller head rotation at the 17.2 km/h ΔV .

29. In summary, research indicates that the head-to-torso rotation limit of 12 degrees will not discourage the development of dynamic head restraint systems. Current systems, such as the one in 2000 Saab 9–3 and the Toyota Whiplash Injury Lessening (WIL) seat (measured 6 degrees of rotation), can meet the head-to-torso rotation limit in this gtr. The United States of America testing has also shown that current static head restraints/seats need more extensive modification to meet the head-to-torso rotation limits. These changes might include increasing the strength of attachment to the seat for adjustable head restraints and optimization of the seat back upholstery for compliance.

30. The gtr requires a HIC15 limit of 500 for the dynamic test option. The gtr does not require the HIC15 limit as a means of limiting whiplash, but instead as a surrogate for the energy absorption test required for the static compliance option. Because HIC15 is easily measured during dynamic testing, it appears to be a more appropriate measuring tool. The HIC15 level of 500 is associated with an 18.8 per cent probability (95 per cent confidence: 1.8 to 32.5 per cent) of moderate (AIS 2+) head injury. ^{14/} While the 80g limit and the HIC15 limit of 500 are not

^{13/} The baseline seat back strength was obtained through static testing of OEM seats and modeling to determine the corresponding amount of seat back rotation. The static testing can be found in Docket NHTSA–1998–4064–2

^{14/} Eppinger, R., et al. (1999) Development of Improved Injury Criteria for the Assessment of Advanced Automotive Restraint Systems—II. Available at

necessarily equivalent, the two requirements do share the same intent of mitigating potential injury related to the head striking a rigid or insufficiently padded head restraint. Data were analyzed from FMVSS No. 201 impactor tests on the back of head restraints and also vehicle seat sled test data. An 80g half sine acceleration was superimposed on the time duration of the impacts from these tests. This resulted in range of HIC15 values from approximately 425 to 800. Accordingly, it is believed a limit of 500 is appropriate. The greatest HIC15 value obtained in testing sled testing using a 50th percentile male dummy was 57. Thus, the HIC15 limit of 500 is practicable. The 500 HIC15 limit will give a strong indication of deleterious effects on the occupant's head and/or neck from deploying head restraints.

31. In the discussion of the dynamic test, some suggested that a trigger point for a sensor driven deployable head restraint should be included. It was stated that such a specification would be similar to one included in other United States of America sled test options, and argued that such a provision should be included in the head restraint standard to ensure objective testing. One participant cited their dynamic head restraint that uses a pyrotechnic design. Once the threshold acceleration is sensed, the pyrotechnic element fires and the head restraint moves about 40 mm to 60 mm forward, depending on the height adjustment, and rotates 9 degrees towards the occupants head. It was argued that the half-sine characteristic of the deceleration pulse is not representative of the pulse that its vehicle would sense in a rear impact and that sensors designed to the half-sine pulse may trigger head restraints unnecessarily. There was a discussion regarding pre-active head restraint systems indicating that a dedicated test protocol may be required to evaluate them (HR-8-10).

32. The specified sled pulse is representative of one experienced in a crash when the head restraint is needed to provide protection. The appropriateness of the ΔV and average acceleration of the pulse is supported by a 2002 Swedish study by Krafft and others (Krafft, M., Kullgren, A., Ydenius, A., and Tingvall, C. (2002) Influence of Crash Pulse Characteristics on Whiplash Associated Disorders in Rear Impacts – Crash Recording in Real-Life Impacts, Traffic Injury Prevention, Vol. 3 (2), pp 141-149). This study examined rear impact crashes with crash recorders where the crash pulse was known (66 such crashes). It examined the relationship between whiplash injury risk and parameters such as ΔV , peak acceleration, average acceleration, and average windowed acceleration for 18 ms, 36 ms, and 80 ms. It found that the mean acceleration best correlated with whiplash injury risk. For most occupants who had whiplash symptoms for longer than a month, the mean acceleration of the crash pulse was greater than 4.5g and above a ΔV of 15 km/h. For this group, the mean acceleration was 5.3g and the average ΔV was 20 km/h. The crash pulse has a 5.6g mean acceleration and 17.3 km/h ΔV . The EEVC have published a review of the latest information available concerning rear impact pulses and their relationship to whiplash and associated disorders (Recommendations for a Low Speed Rear Impact Sled Test Pulse, EEVC, September 2007, <http://www.eevec.org>).^{15/} The report was

http://www-nrd.nhtsa.dot.gov/pdf/nrd-11/airbags/rev_criteria.pdf

^{15/} This final report was made available to the informal group approximately one month before the session of GRSP where this gtr was finalized. This report is a compilation of data in support of presentations that were made to the informal group in January 2006. While the EEVC provided routine updates to the informal group and to GRSP, some Contracting Parties did not have sufficient time to fully evaluate the final report, and therefore have not accepted its conclusions at this time. It is anticipated that it will be part of the discussion within Phase 2.

not able to recommend a single specific pulse shape correlating to injury, instead proposing either a bimodal or triangular, with a ΔV of 20 km/h and mean acceleration of 5-6g to address longer-term (symptoms greater than one month duration).^{16/} Therefore, it is believed that the sensors should be designed to activate the head restraint in such a situation. There is concern that if a trigger point is specified, i.e., specified that the head restraint be activated at a specific point in time as part of the test procedure, there would be no test of the sensors and no assurance that the head restraint would activate during the type of crash simulated by the sled pulse. At this time, GRSP does not recommend including a trigger point.

33. Research indicates that currently available dynamic head restraints can meet the requirements of this option for the gtr. Given that the informal group strongly encourages the development of a future fully developed alternative dynamic test procedure, including dummy recommendations and criteria for evaluating whiplash injuries, that would further encourage innovative dynamic head restraint designs, further discussion concerning revision of the current dynamic option was suspended. Notwithstanding that an alternative dynamic test, incorporating BioRID II, may be introduced into this gtr, it is expected that research to develop a single dynamic test would supersede efforts to revise the Hybrid III dynamic option. However, if future information led to different conclusions than those used to develop the existing procedure and criteria (such as the trigger point or head-to-torso angle rotation), amendments could be made to this option.

34. While GRSP is recommending this dynamic test option, it acknowledges criticism associated with the use of the Hybrid III dummy. Although there is a paper by Ford (SAE 973342), which argues that the 50th percentile male Hybrid III neck is sufficiently biofidelic in the rearward direction. The EEVC report "The Use of the Hybrid III dummy in Low Speed Rear Impact Testing," (September 2007)^{17/} showed the 50th percentile male Hybrid III neck lacks sufficient biofidelity to be a useful tool for rear impact testing and therefore cautioned against its use. The EEVC also observed that the interaction of the rigid thoracic spine of the Hybrid III with the seat back is not humanlike which might affect the real world performance of dynamic head restraints.

35. The group was informed of studies conducted by the EEVC concerning the Hybrid III, BioRID II and RID 3D test devices. At this point the EEVC research ("Dummy Measurements and Criteria for a Low-speed Rear Impact Whiplash Dummy" WG12 Report September 2007)^{17/} has shown that the BioRID II has the highest level of biofidelity of these three candidate dummies.

^{16/} Recommendations for a Low Speed Rear Impact Sled Test Pulse, European Enhanced Vehicle-safety Committee (EEVC) Report, September 2007, <http://www.eevc.org>

^{17/} This final report was made available to the informal group approximately one month before the session of GRSP where this gtr was finalized. This report is a compilation of data in support of presentations that were made to the informal group in January 2006. While the EEVC provided routine updates to the informal group and to GRSP, some Contracting Parties did not have sufficient time to fully evaluate the final report, and therefore have not accepted its conclusions at this time. It is anticipated that it will be part of the discussion within Phase 2.

36. As some Contracting Parties believed that a dynamic test should not be delayed, even if it is only an interim step, the gtr contains recommendations, at the direction of AC.3, to permit the use of the Hybrid III dummy in the assessment of dynamic head restraints. Nevertheless, GRSP acknowledges the agreement of AC.3 that the option for a dynamic test using the BioRID II test dummy also be recognised in this gtr. The informal group also recognise that some Contracting Parties may wish to adopt alternative measures using the BioRID II dummy as soon as procedures suitable to the needs of their jurisdiction are developed.

37. GRSP therefore recommends that, in the first instance, Contracting Parties may introduce into their national or regional laws alternative procedures for use in the dynamic assessment of head restraints. At the discretion of the Contracting Party, these procedures may be used in concert with this gtr. In making this recommendation GRSP understands that those Contracting Parties will bring forward separately, equivalent recommendations for the introduction of these alternative procedures into this gtr.

38. In anticipation of this development, a section is reserved in the regulatory text to be used for the incorporation of amendments to provide equivalent dynamic assessment criteria for the BioRID II dummy (test procedures, performance criteria and associated corridors).

39. For those Contracting Parties which would like to encourage the development of "dynamic" head restraints, but are not comfortable with either of these dynamic options at this time, GRSP is recommending that they be allowed to exempt "dynamic" head restraints in their national legislation. The exemption would include the backset requirement in paragraph 5.1.5., but Contracting Parties or regional economic integration organizations could chose to impose any or all of the requirements of paragraph 5.2.

40. The informal group realizes that a full system whiplash evaluation test, which incorporates the combined performance of the seat and head restraint and uses the BioRID II dummy, is not currently available. GRSP recommends and AC.3 agreed to initiate work for Phase 2 to the gtr which will comprise of the development of full system dynamic test procedures, injury criteria, and associated corridors for the BioRID II dummy.

5.5. Seat Set Up and Measuring Procedure for Static Requirements

41. There were two proposals under discussions concerning the set-up of the seat for the measurement of height and backset. One proposal is to use the manufacturer's recommended seating position as detailed in UNECE Regulation No. 17. The other is to use the procedure that is outlined in the recently adopted United States of America FMVSS No. 202, which positions the seat in the highest position of adjustment and sets the seat back angle at a fixed 25 degrees. GRSP recommends that the seat be measured at the manufacturer's design position to allow additional flexibility to account for vehicles with very upright seat back design angles

42. It was argued that there are several vehicle concepts (e.g., light trucks, minivans, SUV's and full size vans) in which a seat back angle of 25 degrees is not realistic nor feasible, thus leading to a much larger backset using United States of America's procedure as compared to the real world situation. It was stated that SAE J-1100 July 2002 recommends a 22 degree nominal torso design angle.

43. Also, it was stated that 5th percentile female stature occupants do not sit at 25 degree torso angles, but prefer about 18 degrees and some as little as 14. It argued that this more upright back angle greatly reduces the backset to the point it interferes with the head of some of these occupants, not just the hair.

44. After considering the arguments, the informal group believes the flexibility of using the design seat back angle is appropriate. Additional flexibility is needed to account for vehicles with very upright design angles. As a practical matter, this approach provides some additional backset flexibility for most seats, since the typical design seat back angle is 23.5 degrees. Specifying that such a seat be tested at the design seat back angle instead of 25 degrees is roughly equivalent to increasing the backset limit by 4.5 to 6 mm. Therefore, this helps address possible concerns related to comfort.

45. It was also noted that while the Head Restraint Measurement Device (HRMD) was designed to be used at 25 degrees, the device has an articulation to allow for adjustment of the head for varying torso angles. The device can therefore be used at different seat back angles. It is relatively rare that a seat can be adjusted to have a seatback angle of exactly 25 degrees. Thus, even prior to the change to specify seat back angle, the standard specified testing in the adjustment position closest to 25 degrees. For these reasons, there should be no problem in testing vehicles at the design seatback angle.

46. In addition to the set-up of the seat, the method of measuring height and backset was discussed. Some recommend taking all measurements using the R-point as the required reference point. Another proposal is to use the J826 manikin as the primary measurement tool. The use of the R-point allows measurements to be verified to known design points on the vehicle thus improving repeatability. The use of the J826 manikin allows the seat H-point to be measured as it exists in the vehicle. It was argued that options in seat materials and manikin set up can produce recordable differences from one seat to another. UNECE experience shows that the use of the R-point allows measurements to be easily verified on a drawing and is also very repeatable and reproducible when verified in a car. The use of H-point can address differences in measurements caused by seat materials. GRSP agreed to recommend that all static measurements, except for backset, will use the R-point as the required reference point. Because of the sensitivity of the backset measurement to seat to seat differences, GRSP agreed to recommend that this measurement be taken with the H-point as the required reference point; Contracting Parties may choose to allow backset to be measured with R-point as an alternative and take into account the seat to seat differences by requiring a smaller backset limit (see section 5.8. for further discussion of the backset measuring method and determination of limits). The United States of America is currently the only country that specifies use of the H-point for static measurements other than backset. The United States of America agreed to specify R-point for these other measurements, based on a belief that it would not change the safety benefits of their existing regulation. If it were shown that use of R-point instead of H-point changes a measurement to such a degree that safety benefits were lost, they may not be able to adopt R-point for that measurement in their national legislation.

5.6. Height of the Head Restraint

47. The recommendations for the height requirements are intended to prevent whiplash injuries by requiring that head restraints be high enough to limit the movement of the head and neck, even if such movements do not result in hyperextension of the neck. The persistence of whiplash injuries in current vehicles that are regulated to a 700 mm height indicates these designs are not preventing whiplash injuries from occurring. Research has led to the conclusion that prevention of hyperextension alone does not stop whiplash from occurring. Since a 700 mm high head restraint is capable of preventing hyperextension in many occupants, it seems likely that the persistence of whiplash may be the result of the inability of current head restraints to be positioned to sufficiently limit relative head and neck motion in the normal range of motion.

48. Research has shown that head restraints should be at least as high as the centre of gravity (C.G.) of the occupant's head to adequately control motion of the head and neck relative to the torso. This does not mean that there would be no additional benefits for a head restraint with a height greater than the height of the head C.G. However, this is likely to be controlled by other factors such as backset, head restraint shape and the underlying structure of the head restraint under the upholstery.

49. The recent IIHS study also suggests that head restraints that are higher in relation to the head C.G. and closer to the back of the head provide greater protection against whiplash. The informal group notes that head restraints rated "good" by IIHS (integral restraints with a height less than 60 mm below the top to the head and within 70 mm of the rear of the head) reduced the likelihood of whiplash by 36 per cent in females and 10 per cent in males. An 800 mm high head restraint is likely to be high enough to be rated as "good" at all backsets within the "good" range. GRSP believes that the proposed requirement for backset, in conjunction with the proposed height requirements, would provide a significant contribution to improvements in safety.

5.6.1. Front Outboard

50. Both UNECE Regulation No. 17 and the FMVSS No. 202 Final Rule require front outboard head restraints with a minimum height of 800 mm above the R-point/H-point, respectively. A proposal was made to recommend a minimum height of 850 mm, to accommodate the taller citizens of some countries. Using recent anthropometric research (see HR-3-6 and HR-4-16) it was demonstrated that when considering erect sitting height a 95th percentile Netherlands male needs a head restraint height of 849 mm to give protection equivalent to that of the average occupant. The UK submitted data (HR-4-14 and HR-6-11) showing their population is tall enough to need taller head restraints. The UK also provided an EEVC Cost Benefit Analysis (UK Cost Benefit Analysis: Enhanced Geometric Requirements for Vehicle Head Restraints, European Enhanced Vehicle-safety Committee (EEVC), September 2007, <http://www.eevc.org>)^{18/} demonstrating benefits for increasing head restraint height

^{18/} This final report was made available to the informal group approximately one month before the session of GRSP where this gtr was finalized. This report is a compilation of data in support of presentations that were made to the informal group in January 2006. While the EEVC provided routine updates to the informal group and to GRSP, some Contracting Parties did not

above 800 mm.

51. There are concerns with raising the height of the head restraint above 800 mm at this time. It was noted that with an 800 mm head restraint, it is starting to become a challenge for manufacturers to be able to install seats in the vehicle, and a larger head restraint can also restrict occupant visibility (blocking vision rearward and to the side) (see HR-3-5). Additional data was presented (see HR-3-4) that showed that in small cars, 850 mm head restraints could severely restrict rearward vision in the rearview mirror.

52. Additionally, there are concerns that the method in which the height is measured may not reflect the effective height that would be needed to address the safety concerns of taller occupants. There have been some proposals put forth to improve the measurement method, but they were not yet fully developed for inclusion in the gtr. (See section 5.6.4. for further discussion of this measurement method.)

53. At this time, AC.3 has directed that the height requirement be limited to 800 mm, but recommends that the discussion on increasing the height requirement and/or revising the measurement method be continued in Phase 2 to this gtr.

5.6.2. Front Centre and Rear Head Restraints

5.6.2.1. Defining a Front Centre and Rear Head restraint

54. This gtr provides an objective definition and a test procedure for determining the presence of a head restraint. A vehicle seat will be considered to have a head restraint if the seatback or any independently adjustable seat component attached to or adjacent to the front centre or rear seat back, that has a height equal to or greater than 700 mm, in any position of backset and height adjustment.

55. This definition is recommended for the following reasons. Based on the survey of vehicles used to determine the cost effectiveness of this gtr, it was found that a 700 mm threshold captured all of the seats that had adjustable cushion components at the top of the seat back; i.e., what the general public would probably consider being a head restraint.^{19/} Further, this definition of the head restraint will allow the manufacturers to provide a relatively tall seat back (up to 700 mm) without having to comply with rear head restraint requirements. It is anticipated that such taller seat backs might offer some safety benefits to a certain portion of rear seat occupants. Because rearward visibility remains a concern, it is noted that the manufacturer will be able to determine whether providing a seat back structure above 700 mm would be consistent with the amount of rearward visibility they wish to provide.

have sufficient time to fully evaluate the final report, and therefore have not accepted its conclusions at this time. It is anticipated that it will be part of the discussion within Phase 2.

^{19/} The survey included twelve 1999 model year vehicles (9 passenger cars, 1 minivan, and 2 SUVs). Five of the twelve vehicles featured rear seating systems that fell under our definition of the rear head restraint.

5.6.2.2. Height of Front Centre and Rear Head Restraints

56. As stated earlier, the target population using front centre and rear head restraints is considerably less than that for front seats and the occupants of these seats tend to be shorter. It is therefore recommended that optionally installed front centre and rear outboard head restraints have a minimum height of 750 mm. Due to visibility concerns, there is no height requirement for rear centre head restraints.

5.6.3. Clearance Exemption

57. There were several proposals considered regarding the need for some clearance between the head restraint, when it is at its highest position, and the interior roofline (headliner) or rear window. In some vehicles, the required head restraint height may lead to interaction with the vehicle interior. In addition, in 2 door vehicles where seats need to be rotated in order to allow ingress or egress of the vehicle, the required head restraint height may lead to the need for head restraint or seat manipulation (e.g. lowering the head restraint manually) in order to be able to rotate the seat back, thereby impeding emergency exit. Without the clearance, the seat could contact the vehicle structure and slow down the egress process. Some delegates do not believe that emergency egress is an issue and no data were presented to justify this position.

58. One of the proposals considered allows 25 mm of clearance between the head restraint and the interior roofline (headliner) or rear window when the head restraint is in the highest position, the seat is in the lowest position, and the seat back is at design angle. This is based on the safety concern for maintaining the 800 mm height of the head restraint. Another proposal was put forth to allow the clearance exemption be applied when the seat is in any position of adjustment (HR-4-15). It was stated that this exemption was needed to allow the rear seat passengers to exit the vehicle in emergency. Without the clearance, the seat could contact the vehicle structure and slow down the egress process.

59. There is concern that the clearance exemption could be applied when the seat is in the highest position, thereby allowing head restraints as short as 700 mm. It was stated that reducing the height of a head restraint to less than approximately 780 mm will have an impact on the benefits.

60. After considering the reduction in safety benefits and a review of the fleet, it was determined that the clearance exemption is not needed for front or rear seats for folding positions and therefore it is recommended that an exemption of 25 mm only be applied in cases of interference with the interior roofline (headliner) or backlight. An exemption of 50 mm for convertible roofs is also recommended to account for the articulation of the folding top mechanism.

5.6.4. Adjustable Front Head Restraints – Front Contact Surface Area

61. It was initially proposed to include in the gtr the UNECE Regulation No. 17 requirement that the height of the head restraint face be a minimum of 100 mm to ensure sufficient surface for the occupant's head to contact. The UNECE Regulation No. 17 requirement is measured in the same manner as the overall height of the head restraint. There have been concerns expressed that

the measurement taken in this manner does not address the effective height of the restraint. In the case of extremely contoured head restraints, the height of the surface that the head would contact is less than the measured height. This is demonstrated in Figure 2.

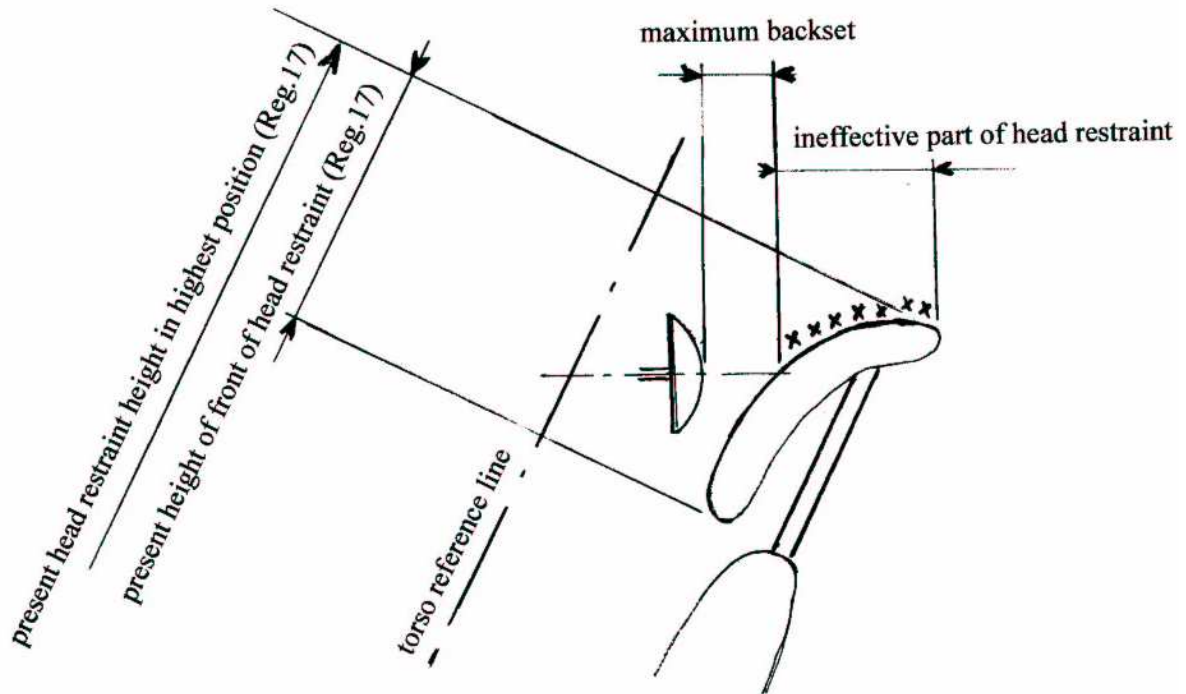

Figure 2 – Ineffective Part of the Head Restraint

62. To address these concerns, a proposal was made that all seats have a minimum front contact surface area on a head restraint (HR-10-2). This proposal incorporates the dimensional requirements of width, minimum 100 mm height of the head restraint, and backset. This proposal is intended to provide a minimum level of protection for the occupant that is being subjected to the dynamic process resulting from a rear end collision. This front contact surface area is measured in an area bounded by two vertical planes set at 85 mm on either side of the centreline, the rear surface which complies with the backset requirement, and the horizontal plane used to measure the height of the head restraint. This proposal was countered by some as not necessary because the shape of the head restraint is governed by the displacement test, energy absorption test, and other requirements.

63. Absent a final decision on how the measurement would be made, analysis to determine whether or not such a requirement would add benefits can not begin. At this time, until a fully developed proposal can be evaluated, GRSP agrees to recommend that the grt not include a minimum height requirement for front surface contact area but recommends that the discussion on this issue be continued in Phase 2 to this grt. Some Contracting Parties may wish to continue regulating a 100 mm minimum height requirement under their current regulation scheme.

5.7. Head Restraint Width

5.7.1. Front and Rear Seats

64. It is recommended that all seats have a minimum head restraint width to ensure a minimum level of protection for the occupant in case they do not contact directly on the centreline. 170 mm is an existing standard and is providing appropriate protection for the occupant. Therefore it is recommended that for this gtr, the minimum width of the head restraints in all seating positions be 170 mm.

5.7.2. Bench Seats

65. There was a proposal to recommend that head restraints have a minimum width of 254 mm when installed in the front outboard positions on bench seats. The need for this requirement has been argued because a bench seat can cause the occupant to sit off-centre from the head restraint (especially if unbelted) therefore a wider head restraint is needed.

66. There was concern for regulating the wider head restraints because the gtr would be regulating misuse. Others stated this requirement is no longer necessary, because the vehicle bench seat of today is considerably different from the vehicle bench seat of 40 years ago. There is also a concern that wider head restraints could impact visibility.

67. No justification was provided for this additional requirement for bench seats. This is not a requirement under the UNECE Regulations and it was not shown that bench seats head restraints with a width of 170 mm pose any additional risks to occupants when compared to bench seats head restraints with a width of 254 mm. Therefore this requirement is not recommended for the gtr.

5.8. Backset

68. The consensus within the biomechanics community is that the backset dimension has an important influence on forces applied to the neck and the length of time a person is disabled by an injury. As early as 1967, Mertz and Patrick first showed that reducing the initial separation between the head restraint and head minimizes loading on the head during a rear impact.^{20/} More recently, the Olsson study, which examined neck injuries in rear end collisions and the correlation between the severity of injuries and vehicle parameters, showed that the duration of neck symptoms was correlated to the head restraint backset. Specifically, reduced backset, coupled with greater head restraint height, results in lower injury severity and shorter duration of symptoms.^{21/}

^{20/} Mertz, H.J.; Patrick, L.M.: "Investigation of the Kinematics and Kinetics of Whiplash, "Proceedings of the 11th Stapp Car Crash Conference, Anaheim, California, 1967; pp. 267-317.

^{21/} Olsson, I., Bunketorp, O., Carlsson G., Gustafsson, C., Planath, I., Norin, H., Ysander, L. An In-Depth Study of Neck Injuries in Rear End Collisions, 1990 International Conference on the Biomechanics of Impacts, September, 1990, Lyon, France. See Table IV and the Appendix.

69. A different study examined sled tests to determine the influence of seat back and head restraint properties on head-neck motion in rear impacts. The study concluded that the head restraint backset had the largest influence on the head-neck motion among all the seat properties examined. With a smaller backset, the rearward head motion was stopped earlier by the head restraint, resulting in a smaller head to torso displacement. The findings indicated that a reduction in backset from 100 mm to 40 mm would result in a significant reduction in whiplash injury risk.^{22/}

70. A study conducted by Eichberger examined real world rear crashes and sled tests with human volunteers to determine whiplash injury risk and vehicle design parameters that influence this risk. The study found a positive correlation between head restraint backset and head to torso rotation of the volunteers and to the reported whiplash injury complaints. The most important design parameters were a low horizontal distance between the head and head restraint as well as the head restraint height.^{23/}

71. A study conducted by Dr. Allan Tencer, PhD, used rigid occupant body models enhanced with finite element models of the cervical spine for simulating rear impacts in order to examine the effect of backset on neck kinematics and forces and moments in the neck. The study concluded larger backset correlates to greater displacement between cervical vertebrae and shearing at the facet capsules that are likely associated with whiplash injury. With the head initially closer to the head restraint, the time difference between the occurrences of the peak upper and lower neck shear forces are smaller. At 50 mm backset and lower, the head moved more in phase with the torso and extension of the head was reduced indicating a lower risk of whiplash injury.^{24/} IIHS, in its studies of head restraints, considers a backset of 70 mm or less to be "good".^{25/}

72. Based on this research, it was concluded that adding a requirement specifying a limit on backset would result in reduced angular displacement between the head and torso in a crash. One method used to assess the potential benefits of a backset limit was through a computer modelling study in which the backset dimension was defined as the distance between two vertical lateral planes; one plane passing through the rearmost point on the headform and the other passing through the forward most part of the head restraint at its centreline. A seat model intended to represent a 1986–1994 Pontiac Grand Am was used with the head restraint positioned in 21 different configurations with varying heights and backsets. The vehicle seat, as

^{22/} Svensson, M., Lovsund, P., Haland, Y., Larsson, S. The Influence of Seat-Back and Head-Restraint Properties on the Head-Neck Motion During Rear-Impact, 1993 International Conference on the Biomechanics of Impacts, September, 1993, Eindhoven, Netherlands.

^{23/} Eichberger A, Geigl BC, Moser A, Fachbach B, Steffan H, Hell W, Langwieder K. Comparison of Different Car Seats Regarding Head-Neck Kinematics of Volunteers During Rear End Impact, International IRCOBI Conference on the Biomechanics of Impact, September, 1996, Dublin.

^{24/} Tencer, A., Mirza, S., Bense, K. Internal Loads in the Cervical Spine During Motor Vehicle Rear-End Impacts, SPINE, Vol. 27, No. 1, pp. 34-42, 2002.

^{25/} The IIHS head restraint rating criteria is discussed at: [Http://www.iihs.org/vehicle_ratings/head_restraints/head.htm](http://www.iihs.org/vehicle_ratings/head_restraints/head.htm)

modelled, was relatively stiff in the longitudinal direction in comparison to those currently on the market. A model of a Hybrid III 50th percentile male was the seat occupant.

73. For both seat stiffnesses, no head-to-torso angular rotation was greater than 2 degrees for head restraints above 750 mm and backsets 50 mm and closer. At backsets up to 100 mm, all head-to-torso angular rotations were less than 21 degrees for head restraints above 750 mm. At a backset of 150 mm, head rotations of 27 and 44 degrees occurred at head restraint heights of 750 mm and 800 mm, respectively. The computer modelling indicates that the lowest head-to-torso rotation value was seen when the backset was approximately 50 mm.

5.8.1. Backset Measurement Method

5.8.1.1. Measurement of Backset using the Head Restraint Measurement Device

74. The Head Restraint Measuring Device (HRMD) was proposed as a device to measure backset. The HRMD consists of a SAE J826 three-dimensional manikin with a headform designed by Insurance Corporation of British Columbia (ICBC) attached. The ICBC headform includes a probe that slides rearward until contact is made with the head restraint, thereby measuring backset. The benefit of using the HRMD is that it eliminates the need for obtaining a reference point from the vehicle manufacturer and it measures the actual seat, as it exists in the real world. During the discussion, many raised issues concerning suitability of the HRMD as a test device and the variability in backset measurements when the HRMD is used.

75. An EEVC report was introduced (EEVC WG20 Report - Static test of Head Restraint Geometry: Test Procedure and Recommendations (October 2007 HR-10-06)^{26/}) which reported on research efforts to produce a repeatable and reproducible method of measuring head restraint geometry (both height and backset). The research highlighted a number of concerns with the use of the HRMD and H-point manikin including its repeatability and reproducibility.

76. The report cited concerns that the geometry of the seat and back pan of the H-point manikin is not well controlled. While discrete points on the surface of these pans are specified, EEVC cautioned that this appears to be insufficient to guarantee that devices from different manufacturers or manufactured to differing versions of particular standards give identical interaction with seats, particularly when the seat is contoured. This could be significant for the accurate determination of torso angle and, in particular, head restraint height and backset when the H-point manikin is used in conjunction with the HRMD.

77. GRSP recommends that it is necessary that the H-point manikin and HRMD machine are considered as a single tool and that they must therefore be calibrated together and remain as a

^{26/} This final report was made available to the informal group approximately one month before the session of GRSP where this gtr was finalized. This report is a compilation of data in support of presentations that were made to the informal group in January 2006. While the EEVC provided routine updates to the informal group and to GRSP, some Contracting Parties did not have sufficient time to fully evaluate the final report, and therefore have not accepted its conclusions at this time. It is anticipated that it will be part of the discussion within Phase 2.

matched pair for use in regulatory assessments. However, GRSP has noted that at this time there is no agreed calibration procedure or generally available calibration equipment to ensure compliance with this recommendation. This poses significant risk with respect to reproducibility. It therefore recommends that, a suitable calibration procedure and equipment be incorporated into regulations that use type approval as a method for approval.

78. Transport Canada conducted a study to verify whether the HRMD is an adequate tool to measure backset. Among other things, the study sought to verify specifications and dimensional tolerances of the HRMD headform and measuring probes. Transport Canada reported that the headform is manufactured to have a mass of $3,150 \pm 50$ grams, and all linear dimensions of the headform are within ± 0.25 mm of the drawing specifications for the headform size "J" provided in ISO DIS 6220 - Headforms for use in the testing of protective helmets. It also reported that both height and backset probes are within ± 2 mm of the RONA Kinetics drawing specifications, and that conformity with the drawing specifications is accomplished with the specially designed "jig". Dimensional drawings for this headform have been provided in the Annex to this gtr.

79. The HRMD is a purely mechanical device. Also, unlike a crash dummy, it is not subjected to crash test forces. The informal group notes that the International Insurance Whiplash Prevention Group (IIWPG), of which ICBC is a member, has identified that variability between three-dimensional manikins can be an issue when using the ICBC HRMD. To address this issue, IIWPG has developed a "Gloria jig" to calibrate the combination together as one single unit. The Working Group understands that the Gloria jig (or its specification) will not be available commercially, but rather will be used by a commercial enterprise to offer a calibration service. For this reason the Working Group cannot specify its use as part of this gtr. Therefore, although no detailed calibration procedure is included in the gtr text, the group recommends that such procedure is developed.

80. In a study conducted by the United States of America (HR-5-4), variation in backset measurements when using multiple laboratories was examined. This study concluded, among other things, that taking the average of three backset measurements at each of three labs reduced the average measurement range between the labs by about half (from 8.5 mm to 4.5 mm). Using an average of three measurements in each of backset position of adjustment, at a 2 standard deviation (s.d.) (97.7 per cent) level of certainty, the expected variability was 5.64 mm; at a 3 s.d. (99.9 per cent) level of certainty, the expected variability was 8.47 mm. Data were presented by Japan showing a variability of up to 29mm (HR-7-10). Data was presented by International Organization of Motor Vehicle Manufacturers (OICA) showing a variability of up to 11 mm. (GRSP-41-22)

81. The Transport Canada study, which used eight vehicles, sought to verify whether the HRMD is an adequate tool to measure backset. It concluded that the HRMD provides repeatable and reproducible results after calibration. It also found that increasing the number of measurements always reduced the backset measurement variability. Using an arithmetic mean of the three measurements in each backset position of adjustment, at a 2 s.d. (97.7 per cent) level of certainty, the expected variability was 2.6 mm; at a 3 s.d. (99.9 per cent) level of certainty, the expected variability was 3.9 mm.

82. Given that both the United States of America and Transport Canada studies indicated that increasing the number of measurements reduces backset measurement variability, it is recommended that backset measured using the HRMD is determined by taking the arithmetic mean of three measurements, rather than using a single measurement.

5.8.1.2. Backset Limit for Measurements using the HRMD

83. As discussed in section 5.8. above, a backset limit of 50 mm is recommended for optimal reduction in the head-to-torso rotation based on computer modeling. To account for the tolerances of the HRMD (discussed in section 5.8.1.1.), it is recommended to set the maximum allowable backset for front outboard designated seating positions to 55 mm.

5.8.1.3. Measurement of Backset using the R-point as the required reference point

84. Another proposal was presented separately by OICA and Japan to measure backset using the using the R-point as the required reference point. The test method was developed using the dimensions of the HRMD to develop a measurement apparatus that can fix the R-point to dimensional information provided by the manufacturer. The repeatability of this method has been shown by Japan to have very good variability per individual seat ranging from 0 mm to 1.0 mm in comparison to the backset measured using the HRMD, which ranged from 2.5 mm to 6.0 mm (GRSP-41-3). In the data provided by OICA, an analysis of the measurements across several seats of the same build indicated excellent repeatability, with differences between minimum and maximum measurements on several samples of the same seat model ranging between 0 and 3 mm. These same OICA data indicated a difference of up to 11 mm on the same seats, using the HRMD data. Therefore, it was decided to recommend that the gtr allow Contracting Parties and regional economic integration organizations the option of allowing manufacturers a choice between H-point and R-point, so that manufacturers which did not wish to market their vehicles in other countries would not have to incur potential expenses in retesting their head restraints to measure backset from the H-point.

5.8.1.4. Backset Limit for Measurement Method using the R-point as the required reference point

85. While theoretically, the backsets measured using the methods outlined in sections 5.8.1.1. and 5.8.1.3. should produce the same results, a comparison of the two measurement methods performed separately by Japan and OICA showed that on average the backset measured from R-point is less than the backset measured using the HRMD. An analysis, of the data provided by OICA, showed an average offset of 7.9 mm. Japan's analysis showed an average offset of 6.7 mm. Taking into account the variability in the build design discussed in section 5.8.1.3, it is recommended to set the backset limit measured with the R-point method at 45 mm.

5.8.2. Backset Limit and Comfort

86. When the United States of America benefit analysis for regulating height and backset was examined, it was noted that all the benefits for the front seat passengers come from regulating the backset. These benefits are achieved by improving the current situation. The United States of America proposed a backset limit of 55 mm measured at manufacturer's design seat back angle

and measured with the HRMD, using the H-point as the initial reference. Others proposed a less stringent backset of 70 mm.

87. The EEVC Cost Benefit Analysis (UK Cost Benefit Analysis: Enhanced Geometric Requirements for Vehicle Head Restraints, EEVC, September 2007, <http://www.eevc.org>) considered the potential costs and benefits of introducing a backset limit of between 40 and 100mm. Benefits were determined by the evaluation of potential casualty savings that might occur as a result of a regulatory change with the cost to industry consistent based on the US data. The study used UK data and proposed that significant savings could be achieved through changes to existing head restraint geometry (including the introduction of a backset requirement, Figure 3.

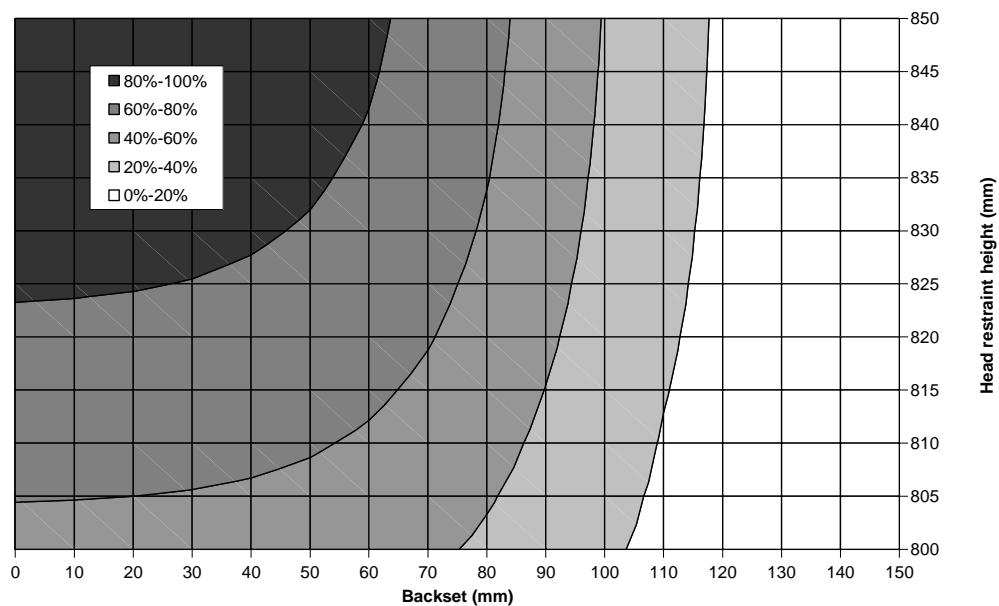

Figure 3 Potential Long-term Whiplash Injury Savings in the UK through increased height and backset requirements.

88. It has been argued that the 55 mm backset requirement is too aggressive and will create significant customer dissatisfaction. It has been noted that occupants may be intolerant of head restraints very close to the back of their head, and because of differences in the occupants size, posture and seat angle preference, the same head restraint can yield different amounts of backset clearance and thus comfort for different individuals. For instance, it was noted that 5th percentile female stature occupants do not sit at 23° torso angles, but prefer about 18° and some as little as 14°. It was also argued that this more upright seatback angle greatly reduces the backset to the point of interference with the head of some of these occupants, and not just the hair.

89. The importance of acceptable comfort for all occupants is recognized, including those of short stature. However, it is believed that the available data do not support the view that the 55 mm requirement will create any significant problems for a well designed and well built seat. As

indicated by a review of IIHS backset data of 2004 model year vehicles, nearly half of the current vehicles measured had a backset of 55 mm or less, more than 30 per cent had a backset of 45 mm or less, and 25 per cent had a backset of 40 mm or less. Moreover, these calculations were made using a seatback angle of 25 degrees, and the change to design seat back angle will provide additional flexibility to typical vehicles. Thus, a large number of vehicles in the current fleet show that the new requirement can be met without causing significant comfort issues.

90. Therefore, GRSP agreed to recommend a backset limit of 55 mm when measured from the H-point and 45 mm when measured from the R-point. At this limit there are significant benefits and the costs of the regulation are reasonable.

5.9. Gaps

5.9.1. Gaps within Head Restraint

91. It is recommended that all gaps within a head restraint are evaluated to ensure a minimum level of protection for the occupant and provide appropriate relief to address rearward visibility concerns. The proposed evaluation requires that if the gap is greater than 60 mm when measured using 165 mm sphere then the gap is tested using the displacement test with the headform applied at the centre of the gap. This is an existing UNECE Regulation No. 17 requirement and is providing appropriate protection for the occupant.

5.9.2. Gaps between bottom of head restraint and top of seat back

92. There were two proposals on how to address the gap between the bottom of the head restraint and the top of the seat back. One proposed that gaps between the bottom of the head restraint and the top of the seat back have maximum dimension of 60 mm when measured using a 165 mm sphere. The other proposal allows a maximum height of 25 mm when measured using the same method to measure overall height as described in UNECE Regulation No. 17. Requiring a minimum gap is recommended to prevent an occupant from contacting the head restraint posts or other structure when the head restraint is in the lowest position. GRSP recommends regulating these gaps using either method. Additionally, GRSP recommends that the gap for non-vertically adjustable head restraints should have a maximum dimension of 60 mm.

5.10. Head Restraint Height Adjustment Retention Devices (Locks)

93. GRSP recommends that performance requirements for adjustable head restraints be included in the gtr which are intended to assure that the front head restraints remain locked in specific positions. A 1982 United States of America NHTSA study (HR-3-13) found that the effectiveness of integral head restraints was greater than adjustable head restraints. The study concluded that this difference in effectiveness was due, in part, to adjustable head restraints not being properly positioned. Although one reason for improper positioning is a lack of understanding on the part of the occupant on where to place the head restraint, it also could be due to the head restraint's moving out of position either during normal vehicle use or in a crash. Adjustment locks can mitigate this problem by helping to retain the adjusted position. IIHS has also been critical of adjustable head restraints, especially when they do not provide locks, in their

evaluation of head restraints. This criticism has manifested itself in that IIHS, in its rating of head restraints, automatically gave adjustable restraints a lower rating on the assumption that these restraints would not be properly adjusted. In addition, it only evaluated adjustable head restraints without locks in their lowest position. The United States of America has received comments during its regulatory process to update its head restraint regulation from consumer groups and vehicle manufacturers supporting adjustable head restraints that lock.

94. The proposed requirements of this gtr are expected to improve the performance of all adjustable head restraints. The performance of adjustable head restraints may be further improved if steps are taken to ensure that a restraint remains in position after it has been set by the user.

95. Therefore, GRSP is recommending that adjustable head restraints for the front outboard seating positions must maintain their height (i.e., lock) in several height positions under application of a downward force. In addition to locking at a position of not less than 800 mm, they must also lock at the highest adjustment positions. It may be that, for some designs, the highest position is at 800 mm. Adjustable head restraints for the front centre and rear outboard seating positions must lock at the highest position of adjustment above 750 mm, if this position exists. In addition to locking at these specified positions of height adjustment, both front centre and rear outboard head restraints must be capable of retaining the minimum height of 750 mm under application of a downward force. Adjustable head restraints for rear centre seating positions must lock at the highest position of adjustment above 700 mm and be capable of retaining the minimum height of 700 mm under the application of a downward force.

96. The proposed height adjustment retention lock test begins by applying a small initial load to the head restraint. A headform is used to apply the load and a reference position is recorded. The reference position is measured with this load applied to eliminate variability associated with the soft upholstery of the head restraint. A 500 N load is then applied through the headform to test the locking mechanism. Finally, the load is then reduced to the initial value and the headform is checked against its initial position. In order to comply, the locking and limiter mechanisms must not have allowed the headform to have moved more than 25 mm from the initial reference position.

97. Concern was expressed that this load was overly severe, the forces were being applied in the wrong direction, and that such a requirement might negatively affect dynamic head restraint system design. Data from Hybrid III dummies was provided on the representativeness of the force levels (HR-2-8). For 23 rear impact crash tests, an average downward force was 539 N. Based on these tests, the informal group believes this load is appropriate. Participants have stated that there are advanced dynamic head restraints that, due to their mechanical nature, displace more than 25 mm during the preload of the backset retention test. It was anticipated that there may be advanced designs which, by their dynamic nature, are unable to pass the static performance requirements in their undeployed positions. This is why Contracting Parties can allow dynamic systems to meet the dynamic test option or to full or partially exempt the dynamic systems from the gtr requirements.

98. It was also questioned whether to take the measurement at the top or bottom of the head restraint. There was concern at taking the measurement at the top of the head restraint as it

does not take into account the foam hysteresis (HR-6-8). Therefore, GRSP recommends a test procedure that uses the bottom of the head restraint as reference.

5.11. Removability

99. GRSP is recommending new head restraint requirements to ensure that vehicle occupants receive better protection from whiplash and related injuries. To achieve this purpose, the informal group wants to take reasonable steps to increase the likelihood that a head restraint is available when needed. If head restraints were too easily removable, chances are greater that they will be removed. That, in turn, increases the chances that the restraints might not be reinstalled correctly, if at all. By prohibiting removability without the use of deliberate action distinct from any act necessary for upward adjustment, the likelihood of inadvertent head restraint removal will be reduced, thus increasing the chances that vehicle occupants will receive the benefits of properly positioned head restraints. While the informal group wants to increase the likelihood that a head restraint is available when needed, it is also important to ensure that head restraints, especially in the rear outboard designated seating positions, can be removed in order to improve rear visibility, child restraint accommodation, and cargo carrying capacity.

5.12. Non-use Positions

100. The informal group is aware of rear seat head restraint designs which have the goal of lessening the rearview obstruction by moving out of the way into non-use positions. GRSP is not recommending to specifically compensate for the potential rearview obstruction. However, GRSP is recommending language which will allow for folding or retractable head restraints for rear seats if they meet specific criteria. If such a head restraint is adjusted to a non-use position, i.e., any position in which its minimum height is less than that proposed in this document or in which its backset is more than that proposed in this document, it must give the occupant an unambiguous physical cue that the head restraint is not properly positioned by altering the normal torso angle of the occupant by at least 10 degrees, being rotated 60 degrees forward or rearward, complying with the "discomfort metric" which defines the zone the head restraint is in when it is in the non-use position, or it must automatically return to a position where it would comply with all provisions of the regulation when the seat is occupied.

5.12.1. Front Outboard Seats

101. The informal group believed it was important to balance the need to ensure that the head restraint is in the proper position while maintaining the functionality of the seat. In some current designs the head restraint can be placed in a non-use position when the vehicle seat is folded down to increase the cargo capacity of the vehicle. It has been proposed to allow non-use positions in the front outboard seats, as long as they automatically return to the proper position when the seat is occupied. GRSP is recommending a test procedure using the 5th percentile female Hybrid III dummy or a human surrogate to evaluate these systems.

5.12.2. Front Centre and Rear Seats

5.12.2.1. Manually adjusted non-use positions

102. It is recommended to regulate of non-use positions in the rear seats, as long as the position is "clearly recognizable to the occupant". There is discussion on how to objectively evaluate this requirement. One proposal is to define "clearly recognizable" as a head restraint that rotates a minimum of 60 degrees forward or aft. There was concern that this definition is too design restrictive as the sole method and additional methods have been proposed (HR-4-13).

103. The United States of America developed a human factors study to determine if an occupant would be likely to reposition their head restraint as a function of the torso angle change the head restraint produced in the non-use position (HR-5-23). The baseline seat for this study was the second row captain's chair of a 2005 model year Dodge Grand Caravan. In its original equipment manufacturer configuration, the seat created a nominal 5 degree torso angle change between its non-use and in-use positions. The head restraint was then modified by introducing two forward offsets that generated either a 10 or 15 degree torso angle change. One other condition that was used was to attach a label to the head restraint in the 5 degree condition. The label was modified from a label used by Volvo.

104. Of the participants who adjusted the head restraint, 88 per cent adjusted it immediately after sitting down. The 5 degree condition and label condition were unsuccessful in motivating participants to adjust the head restraint. For the 5 degree condition, only 3 out of 20 participants (15 per cent) adjusted the head restraint. None of the participants (0 out of 20) adjusted the head restraint as a result of the label. The 10 degree condition had a nearly 80 per cent success rate, 19 out of 24. Only four participants were run in the 15 degree condition since the percentage of participants who adjusted the head restraint in the 10 degree condition was high. The 15 degree condition had a 100 per cent rate of adjustment. Based on the results of this study, GRSP agreed to recommend the 10 degree torso angle change option as an alternative.

105. Some experts and participants support the use of labels since these head restraints are optional, and a label in a non-use position is better than no label at all. Additionally, the need for labels was suggested because the use of the torso angle change method or discomfort metric may be incompatible with the installation of child restraints. Some experts do not support the use of labels, because there are already too many labels in the vehicles and, based on the United States of America study, the labels were ineffective in causing the occupant to move the head restraint out of the non-use position, although 50 per cent of those questioned understood what the label meant, and an additional 30 per cent understood that the head restraint was adjustable. To accommodate all views in the gtr, labels will be recommended as an optional method to be accepted by the Contracting Party. Based on the available data, Contracting Parties can choose the level of risk they are comfortable with.

106. Another proposal under consideration is a "discomfort metric" which defines the zone the head restraint is in when it is in the non-use position. It is a method to define objectively the requirement that a non-use position be "clearly recognizable to the occupant". To reduce the subjectivity of the UNECE language, a method was developed based on the argument that something which is uncomfortable, e.g. a step in the contour of the seat back, can be considered clearly recognizable. To make the criterion objective and measurable the discomfort metric option defines geometrical requirements, the size and location of the seat back contour, when the head restraint is in the non-use position. In contrast to the "change of torso angle" option, which results mainly in a more upright seating position, the discomfort metric option is focused on

discomfort felt in the back of the occupant and therefore results in an overall uncomfortable seating condition.

107. To determine the appropriate dimensional criteria, several studies were conducted by OICA. One study (HR-8-11) showed that the thickness of the head restraint is more important than the height of the lower edge of the head restraint, as evidenced by the occupant moving the head restraint from a non-use position to an in-use position. The other study showed that, when the discomfort metric dimensions are the same as some current seat designs i.e. so called "shingled" head restraints, a large percentage of small females can recognize the head restraint is out of position.

108. A third study was conducted (GRSP-41-21) with 79 candidates who represent the body height distribution of the public. The study showed that a shingled head restraint, designed with a thickness of 40 mm and a position of the lower edge of the head restraint in non-use position of 460 mm above the R-point, is sufficient to result in a recognition rate of 92%. While some countries felt these results were optimistic, in that the test conditions may have predisposed participants to concentrate on comfort, all agree that the recognition rate would likely be sufficiently high to justify using these numbers in the gr.

109. Apart from thickness and maximum height criteria for the lower edge of the head restraint, there are two additional criteria incorporated in the discomfort metric option. A minimum height of the lower edge prevents a seat design where the lower edge is settled in the area of the seat cushion and cannot be felt by the occupant anymore. Another criterion requires the step in the seat back contour to rise up to the full thickness within a height distance of 25 mm, which assures that it is really a step and not a smooth intersection, which would not be felt by the occupant.

5.12.2.2. Automatically adjusted non-use positions

110. There is consensus, for the rear seats, to recommend regulation of non-use positions that automatically return to the proper position when the seat is occupied. A test procedure using the 5th percentile female Hybrid III dummy or a human surrogate to evaluate these systems has been added to the gr.

5.13. Energy Absorption

5.13.1. Impactor

111. GRSP is recommending an energy absorption requirement specifying that when the front of the head restraint is impacted by a headform the deceleration of the headform must not exceed 80g continuously for more than 3 milliseconds. This recommendation is different from the current United States of America and UNECE Regulations in that it does not specify a type of impactor, but rather a required energy. This would allow either the linear impactor, the free motion impactor, or the pendulum impactor to be used for testing. Studies showed that the results of the test were similar regardless of what type of impactor was used (HR-4-8, HR-5-6).

5.13.2. Radius of Curvature

112. The informal group discussed incorporating the UNECE Regulation No. 17 requirement that designated parts of the front of the head restraint shall not exhibit areas with a radius of curvature less than 5 mm pre- and post-test. There was concern that a breakage could occur during the test which would produce a sharp edge. This sharp edge could harm occupants in a secondary impact. The informal group was unable to agree on a test procedure and therefore the requirement was not included in the gtr at this time. Due to these concerns, some Contracting Parties may wish to continue regulating for radius of curvature under their current regulation scheme.

5.14. Displacement Test Procedures/Adjustable Backset Locking Test/Ulimate Strength

113. GRSP is recommending the incorporation of requirements to evaluate the head restraint's ability to resist deflection and significant loading. The displacement test requires that a head restraint cannot deflect more than 102 mm when a 373 Nm moment is applied to the seat. Additionally, the seat system must not fail when an 890 N load is applied to the seat and maintained for 5 seconds.

114. Additionally, GRSP is recommending, based on Contracting Party determination, that head restraints with adjustable backset maintain their position while under load. Some strongly believe that if an occupant adjusts his head restraint backset so that it is less than the requirement, then he should have some assurance that it will maintain that position when loaded. Some further believe, that this requirement should only apply to required head restraints and not those optionally installed. Others strongly believed that the safety needs are met at the requirement. Therefore the gtr was drafted so that a Contracting Party can designate whether adjustable head restraints will be tested at all positions of backset and to which head restraints this will apply. The test for adjustable head restraints incorporates both the evaluation for total displacement of the head restraint and the evaluation of the locking mechanism for the adjustable backset.

6. LEADTIME

115. It is recommended that Contracting Parties implementing this gtr allow adequate lead time before full mandatory application, considering the necessary vehicle development time and product lifecycle.

7. REGULATORY IMPACT AND ECONOMIC EFFECTIVENESS

116. In the United States of America it is estimated the annual number of whiplash injuries to be approximately 272,464. 251,035 of these injuries involve occupants of front outboard seats, 21,429 injuries involve occupants of rear outboard seats. The average economic cost of each whiplash injury resulting from a rear impact collision is \$9,994 (2002 dollars) which includes \$6,843 in economic costs and \$3,151 in quality of life impacts. The total annual cost of rear impact whiplash injuries is approximately \$2.7 billion. Based on a study conducted by Kahane in 1982, the United States of America estimates that current integral head restraints are 17 per

cent effective in reducing whiplash injury in rear impact crashes for adult occupants, while adjustable head restraints are 10 per cent effective in reducing whiplash injury in rear impact crashes for adult occupants (HR-3-14). The overall effectiveness of current head restraints for passenger cars is estimated to be 13.1 per cent.

117. It was estimated that upgrading the head restraint requirements would yield the following benefits ^{27/} :

- (a) For front seats, reducing the backset to 55 mm increases the head restraint effectiveness 5.83 per cent, resulting in 12,231 fewer whiplash injuries for front seat occupants each year.
- (b) For rear seats, increasing the height of voluntarily installed rear head restraints increases the effectiveness of these head restraints by 17.45 per cent, resulting in 1,559 fewer whiplash injuries for rear seat occupants each year.
- (c) The total annual reduction in rear impact whiplash injuries is thus estimated at (12,231+1,559) 13,790 or 5 per cent of the annual number of whiplash injuries (272,464).

118. It can be noted that with respect to whiplash injuries, a 5 per cent reduction in the incidence of whiplash is a significant step forward because the current head restraints only prevent 13.1 per cent of whiplash injuries occurring in rear impact crashes.

119. There are several reasons to believe that the potential benefits of this regulation are understated. First, a separate analysis of benefits associated with reduced position retention requirement was not performed. Second, in the injury data there is an inherent underestimation of whiplash injury costs due to the underreporting of such injuries. Whiplash injuries are often underreported because of late onset of symptoms. Third, no estimate of the potential reduction of higher-level neck injury more than Average Injury Scale (AIS) 1 was made. Although such injuries are much less frequent, their associated costs are much greater.

8. REVIEW OF EXISTING INTERNATIONAL REGULATIONS

120. The following existing regulations, directives, and standards pertain to head restraints:

- (a) UNECE Regulation No. 17 - Uniform provisions concerning the approval of vehicles with regard to the seats, their anchorages, and any head restraints.
- (b) UNECE Regulation No. 25 - Uniform provisions concerning the approval of head restraints (Head Rests), whether or not incorporated in vehicle seats.
- (c) European Union Directive 74/408/EEC (consolidated), relating to motor vehicles with regard to the seats, their anchorages and head restraints.
- (d) European Union Directive 78/932/EEC.
- (e) European Union Directive 96/03/EC, adapting to technical progress Council Directive 74/408/EEC relating to the interior fittings of motor vehicles (strength of seats and of their anchorages).
- (f) United States of America Code of Federal Regulations Title 49: Transportation; Part 571.202: Head Restraints.
- (g) Australian Design Rule 3/00, Seats and Seat Anchorages.

^{27/} These benefits were based on measurements taken from the H-point. Benefits realized from the R-point may be different.

- (h) Australian Design Rule 22/00, Head Restraints.
- (i) Japan Safety Regulation for Road Vehicles Article 22 – Seat.
- (j) Japan Safety Regulation for Road Vehicles Article 22-4 – Head Restraints, etc.
- (k) Canada Motor Vehicle Safety Regulation No. 202 – Head Restraints.
- (l) International Voluntary Standards -SAE J211/1 revised March 1995 – Instrumentation for Impact Test – Part 1 – Electronic.
- (m) Korea Safety Regulation for Road Vehicles Article 99 – Head Restraints.

Additionally, research and activities being conducted by European Enhanced Vehicle Safety Committee (EEVC) Working Group 12, EEVC Working Group 20, EuroNCAP, and Korea NCAP were also considered.

B. TEXT OF REGULATION

1. PURPOSE:

This regulation specifies requirements for head restraints to reduce the frequency and severity of injuries caused by rearward displacement of the head.

2. APPLICATION / SCOPE:

This regulation applies to all Category 1-1 vehicles; Category 1-2 vehicles with a Gross Vehicle Mass of up to 4,500 kg; and Category 2 vehicles with a Gross Vehicle Mass of up to 4,500 kg.^{1/}

3. DEFINITIONS:

3.1. "Adjustable head restraint" means a head restraint that is capable of movement independent of the seatback between at least two positions of adjustment intended for occupant use.

3.2. "Backlight" means rearward-facing window glazing located at the rear of the roof panel.

3.3. "Backset" means the horizontal distance between the front surface of the head restraint and the rearmost point of the head restraint measurement device, as measured in accordance with Annex 4 or Annex 5.

3.4. "Head restraint" means, at any designated seating position, a device that limits rearward displacement of a seated occupant's head relative to the occupant's torso and that has a height equal to or greater than 700 mm at any point between two vertical longitudinal planes passing at 85 mm on either side of the torso line, in any position of backset and height adjustment, as measured in accordance with Annex 1.

3.5. "Head restraint measurement device (HRMD)" means a separate head shaped device used with the H-point machine with the head form, as defined in Annex 4, attached with sliding scale at the back of the head for the purpose of measuring backset.^{2/}

^{1/} A contracting party may restrict application of the requirements in its domestic legislation if it decides that such restriction is appropriate.

^{2/} The technical specifications and detailed drawings of HRMD, are deposited with the Secretary General of the United Nations and may be consulted on request at the secretariat of the UNECE, Palais des Nations, Geneva, Switzerland.

- 3.6. "Three-dimensional H-point machine" (H-point machine) means the device used for the determination of "H-points" and actual torso angles. This device is defined in Annex 13.
- 3.7. "Head restraint height" means the distance from the R-point, measured parallel to the torso line to the top of the head restraint on a plane normal to the torso line.
- 3.8. "Intended for occupant use" means, when used in reference to the adjustment of a seat and head restraint, adjustment positions used by seated occupants while the vehicle is in motion, and not those intended solely for the purpose of allowing ease of ingress and egress of occupants; access to cargo storage areas; and storage of cargo in the vehicle.
- 3.9. "H-point" means the pivot centre of the torso and thigh of the H-point machine when installed in a vehicle seat in accordance with Annex 12. Once determined in accordance with the procedure described in Annex 12, the "H" point is considered fixed in relation to the seat-cushion structure and is considered to move with it when the seat is adjusted.
- 3.10. "R-point" means a design point defined by the vehicle manufacturer for each designated seating position and established with respect to the three-dimensional reference system as defined by Annex 11. The R-point:
- 3.10.1. Establishes the rearmost normal design driving or riding position of each designated seating position in a vehicle;
- 3.10.2. Has coordinates established relative to the designed vehicle structure;
- 3.10.3. Simulates the position of the centre pivot of the human torso and thigh;
- 3.10.4. Is defined in Annex 12 of this regulation.
- 3.11. "Top of the head restraint" means the point on the head restraint centreline with the greatest height.
- 3.12. "Torso line" means the centreline of the probe of the H-point machine with the probe in the fully rearward position.
- 3.13. "Actual torso angle" means the angle measured between a vertical line through the H-point and the torso line using the back angle quadrant on the H-point machine. The actual torso angle corresponds theoretically to the design torso angle.

3.14. "Design torso angle" means the angle measured between a vertical line through the R-point and the torso line in a position which corresponds to the design position of the seat back established by the vehicle manufacturer.

4. GENERAL REQUIREMENTS

4.1. Whenever a range of measurements is specified, the head restraint shall meet the requirement at any position of adjustment intended for occupant use.

4.2. In each vehicle subject to the requirements of this regulation, a head restraint shall be provided at each front outboard designated seating position, conforming to either paragraph 4.2.1. or paragraph 4.2.2.

4.2.1. The head restraint shall conform to paragraphs 5.1., 5.2., 5.4., and 5.5. of this regulation.

4.2.2. The head restraint shall conform to paragraphs 5.1.1. through 5.1.4., 5.3., 5.4., and 5.5. of this regulation.

4.3. For vehicles equipped with rear outboard and/or front centre head restraints, the head restraint shall conform to either paragraph 4.3.1. or paragraph 4.3.2.

4.3.1. The head restraint shall conform to paragraphs 5.1.1. through 5.1.4., 5.2., 5.4., and 5.5. of this regulation.

4.3.2. The head restraint shall conform to paragraphs 5.1.1. through 5.1.4., 5.3., 5.4., and 5.5. of this regulation.

4.4. For vehicles equipped with rear centre head restraints, the head restraint shall conform to either paragraph 4.4.1 or 4.4.2.

4.4.1. The head restraint shall conform to paragraphs 5.1.2. through 5.1.4., 5.2., 5.4., and 5.5. of this regulation.

4.4.2. The head restraint shall conform to paragraphs 5.1.2. through 5.1.4., 5.3., 5.4., and 5.5. of this regulation.

4.5. This regulation does not apply to auxiliary seats such as temporary or folding jump seats or to side-facing or rear-facing seats.

4.6. At designated seating positions incapable of seating the test dummy specified in paragraph 5.3. of this regulation, the applicable head restraint shall conform to either paragraph 4.2.1., or 4.3.1, or 4.4.1. of this regulation, as appropriate.

5. PERFORMANCE REQUIREMENTS

5.1. Dimensional requirements

5.1.1. Minimum Height

5.1.1.1. General specifications

The following requirements on minimum height shall be demonstrated in accordance with Annex 1.

5.1.1.2. Front outboard designated seating positions

The top of a head restraint located in a front outboard designated seating position shall, except as provided in paragraph 5.1.1.4. of this regulation, have a height of:
(a) not less than 800 mm in at least one position of head restraint adjustment, and
(b) not less than 750 mm in any position of head restraint adjustment.

5.1.1.3. Front centre designated seating positions equipped with head restraints

The top of a head restraint located in the front centre designated seating position shall have a height of not less than 750 mm in any position of adjustment, except as provided in paragraph 5.1.1.4. of this regulation.

5.1.1.4. Exception

The top of a head restraint located in a front outboard designated seating position shall have a height of not less than 700 mm when the head restraint is adjusted to its lowest position intended for occupant use; if the interior surface of the vehicle roofline, including the headliner, physically prevents a head restraint, located in the front designated seating position, from attaining the height required by paragraphs 5.1.1.2. and 5.1.1.3. of this regulation. In those instances, the vertical distance between the top of the head restraint and the interior surface of the roofline, including the headliner, shall not exceed 50 mm for convertibles and 25 mm for all other vehicles, when the head restraint is adjusted to its highest position intended for occupant use.

5.1.1.5. Rear outboard designated seating positions equipped with head restraints

The top of a head restraint located in a rear outboard designated seating position shall have a height of not less than 750 mm in any position of adjustment, except as provided in paragraph 5.1.1.6. of this regulation,

5.1.1.6. Exception

The requirements of paragraph 5.1.1.5. of this regulation do not apply if the

interior surface of the vehicle roofline, including the headliner, or backlight physically prevent a head restraint, located in the rear outboard designated seating position, from attaining the required height. In those instances, the maximum vertical distance between the top of the head restraint and interior surface of the roofline, including the headliner, or the backlight shall not exceed 50 mm for convertibles and 25 mm for all other vehicles, when the head restraint is adjusted to its highest position intended for occupant use.

5.1.2. Minimum width

When measured in accordance with Annex 2, the lateral width of a head restraint shall be not less than 85 mm on either side of the torso line (distances L and L' measured as per Annex 2).

5.1.3. Gaps within head restraint

If a head restraint has any gap greater than 60 mm when measured in accordance with Annex 3, the maximum rearward displacement of the head form shall be less than 102 mm when the head restraint is tested at that gap in accordance with Annex 6.

5.1.4. Gaps between head restraint and the top of the seat back

When measured in accordance with Annex 3, there shall not be a gap greater than 60 mm between the bottom of the head restraint and the top of the seat back if the head restraint can not be adjusted in height.

In the case of head restraints adjustable in height to more than one position intended for occupant use, when measured in accordance with Annex 3, there shall not be a gap greater than 25 mm between the bottom of the head restraint and the top of the seat back, with the head restraint adjusted to its lowest height position.

5.1.5. Backset requirements

5.1.5.1. General specifications

5.1.5.1.1. Head restraints on the front outboard designated seating positions shall meet the backset requirements of paragraph 5.1.5.2.

5.1.5.2. Static maximum backset requirements

5.1.5.2.1. For height adjustable head restraints, the requirements shall be met with the top of the head restraint in all height positions of adjustment between 750 mm and 800 mm, inclusive. If the top of the head restraint, in its lowest position of adjustment, is above 800 mm, the requirements of this regulation shall be met at that position only.

- 5.1.5.2.2. When measured in accordance with Annex 4, the backset shall not be more than 55 mm. Based on a determination by each Contracting Party or regional economic integration organization, the manufacturer may be allowed the option to measure in accordance with Annex 5 as an alternative, in which case the backset shall not be more than 45 mm.
- 5.1.5.2.3. In the case of Annex 4, if the front outboard head restraint is not attached to the seat back, it shall not be possible to adjust the head restraint such that the backset is more than 55 mm when the seat back inclination is positioned closer to vertical than the position specified in Annex 4.
- 5.1.5.2.4. The above requirements on maximum backset shall be demonstrated by taking the arithmetic mean of 3 measurements obtained in accordance with Annex 4 or Annex 5.
- 5.2. Static performance requirements
- Each head restraint shall conform to paragraphs 5.2.1. through 5.2.4. of this regulation.
- 5.2.1. Energy absorption
- When the front surface of the head restraint is impacted in accordance with Annex 7, the deceleration of the head form shall not exceed 785 m/s^2 (80g) continuously for more than 3 milliseconds.
- 5.2.2. Adjustable head restraint height retention
- When tested in accordance with Annex 8, the mechanism of the adjustable head restraint shall not fail in such a way as to allow downward movement of the head restraint by more than 25 mm.
- 5.2.3. Displacement and backset retention
- 5.2.3.1. General Specifications.
- 5.2.3.1.1. In the case of head restraints with an adjustable backset, the head restraint shall conform to the displacement and backset retention requirements of paragraph 5.2.3.2. of this regulation. However, based on the determination of each Contracting Party or regional economic integration organization, the manufacturer may be allowed to apply the displacement requirements of paragraph 5.2.3.3. as an alternative.
- 5.2.3.1.2. All other head restraints shall conform to the displacement requirements of paragraph 5.2.3.3.

5.2.3.2. Displacement and backset retention.

5.2.3.2.1. When the head restraint is tested in any position of backset adjustment in accordance with Annex 6, the head form shall:

5.2.3.2.1.1. Not be displaced more than 25 mm during the application of the initial reference moment of 37 Nm;

5.2.3.2.1.2. Not be displaced more than 102 mm perpendicularly and rearward of the displaced extended torso line during the application of a 373 Nm moment about the R-point; and

5.2.3.2.1.3. Return to within 13 mm of its initial reference position after the following sequence occurs: application of a 373 Nm moment about the R-point; reduction of the moment to 0 Nm; and by re-application of the initial reference load 37 Nm.

5.2.3.3. Displacement

5.2.3.3.1. When the head restraint is tested in the rearmost (relative to the seat) position of horizontal adjustment (if provided) in accordance with Annex 6, the head form shall not be displaced more than 102 mm perpendicularly and rearward of the displaced extended torso line during the application of a 373 Nm moment about the R-point.

5.2.3. Head restraint strength

When the head restraint is tested in accordance with Annex 6, the load applied to the head restraint shall reach 890 N and remain at 890 N for a period of 5 seconds.

5.3. Dynamic performance requirements

5.3.1. Based on a determination by each Contracting Party or regional economic integration organization, either a Hybrid III 50th percentile male dummy^{3/} or a BioRID II 50th percentile male dummy shall be used to determine compliance. If a Hybrid III dummy is used, the head restraint shall meet the requirements of paragraph 5.3.2. If a BioRID II dummy is used, the head restraint shall meet the requirements of paragraph 5.3.3.

5.3.2. Hybrid III Requirements

5.3.2.1. When tested during forward acceleration of the dynamic test platform, in

^{3/} The technical specifications and detailed drawings of Hybrid III dummy, corresponding to the principal dimensions of a 50th percentile male of the United States of America, and the specifications for its adjustment for this test are deposited with the Secretary General of the United Nations and may be consulted on request at the secretariat of the UNECE, Palais des Nations, Geneva, Switzerland.

accordance with Annex 9, at each designated seating position equipped with a head restraint, the head restraint shall conform to paragraphs 5.3.2.2 and 5.3.2.3.

5.3.2.2. Angular rotation

Limit the maximum rearward angular rotation between the head and torso of the 50th percentile male Hybrid III test dummy to 12 degrees for the dummy in all outboard designated seating positions;

5.3.2.3. Head injury criteria

Limit the maximum HIC15 value to 500. HIC15 is calculated as follows: For any two points in time, t_1 and t_2 , during the event which are separated by not more than a 15 millisecond time interval and where t_1 is less than t_2 , the head injury criterion (HIC15) is determined using the resultant head acceleration at the centre of gravity of the dummy head, a_r , expressed as a multiple of g (the acceleration of gravity) and is calculated using the expression:

$$\text{HIC} = \left[\frac{1}{(t_2 - t_1)} \int_{t_1}^{t_2} a_r dt \right]^{2.5} (t_2 - t_1)$$

5.3.3. BioRID II Requirements

Reserved: Until BioRID II requirements are included in this regulation or adopted in the national regulation of a Contracting Party or regional economic integration organization, head restraints shall comply with either paragraph 5.3.3.1. or 5.3.3.2. as appropriate.

5.3.3.1. Based on a determination by each Contracting Party or regional economic integration organization, dynamic head restraints shall comply with any or all of the items contained in paragraph 5.2.

5.3.3.2. All other head restraints shall meet the requirements of either paragraph 4.2.1, 4.3.1, or 4.4.1, as appropriate.

5.4. Non-use positions

5.4.1. A driver head restraint shall not have a non-use position.

5.4.2. A front outboard passenger head restraint may be adjusted to a position at which its height does not comply with the requirements of paragraph 5.1.1.2. of this regulation. However, in any such position, the front outboard passenger head restraint shall meet paragraph 5.4.4.1. of this regulation.

5.4.3. All rear head restraints and any front centre head restraint may be adjusted to a position at which their height does not comply with the requirements of either

paragraph 5.1.1.3. or 5.1.1.5. of this regulation. However, in any such position, the head restraint shall also meet one additional requirement from a set of several alternative test requirements.

The set of alternative test requirements may be, at the choice of the manufacturer either paragraph 5.4.4.1., or 5.4.4.2., or 5.4.4.3. or 5.4.4.4. of this regulation.

Based on a determination by each Contracting Party or regional economic integration organization, the manufacturer may also be allowed to choose paragraph 5.4.4.5. of this regulation as an alternative to paragraphs 5.4.4.1. through 5.4.4.4.

5.4.4. Alternative requirements

All of the items described in paragraphs 5.4.4.1. through 5.4.4.5. are permitted as additional features.

- 5.4.4.1. In all designated seating positions equipped with head restraints, except the driver's designated seating position, the head restraint shall automatically return from a non-use position to a position in which its minimum height is not less than that specified in paragraph 5.1.1. of this regulation when a 5th percentile female Hybrid III test dummy^{4/} is positioned in the seat in accordance with Annex 10. At the option of the manufacturer, instead of using a 5th percentile female Hybrid III test dummy, human beings may be used as specified in Annex 10.
- 5.4.4.2. In front centre and rear designated seating positions equipped with head restraints, the head restraint shall, when tested in accordance with Annex 10, be capable of manually rotating either forward or rearward by not less than 60 degrees from any position of adjustment intended for occupant use in which its minimum height is not less than that specified in paragraph 5.1.1. of this regulation.
- 5.4.4.3. When measured in accordance with Annex 10, the lower edge of the head restraint (HLE) shall be not more than 460 mm, but not less than 250 mm from the R-point and the thickness (S) shall not be less than 40 mm.
- 5.4.4.4. When tested in accordance with Annex 10, the head restraint shall cause the torso line angle to be at least 10 degrees closer to vertical than when the head restraint is in any position of adjustment in which its height is not less than that specified in paragraph 5.1.1. of this regulation.

^{4/} The technical specifications and detailed drawings of Hybrid III dummy, corresponding to the principal dimensions of a 5th percentile female of the United States of America, and the specifications for its adjustment for this test are deposited with the Secretary General of the United Nations and may be consulted on request at the secretariat of the UNECE, Palais des Nations, Geneva, Switzerland.

- 5.4.4.5 The head restraint shall be marked with a label in the form of a pictogram which may include explanatory text. The label shall either provide an indication when the head restraint is in a non-use position or provide information to enable an occupant to determine whether the head restraint is in a non-use position. The label shall be durably affixed and located such that it is clearly visible by an occupant when entering the vehicle to the designated seating position. Examples of possible designs of pictograms are shown in Figure 1.

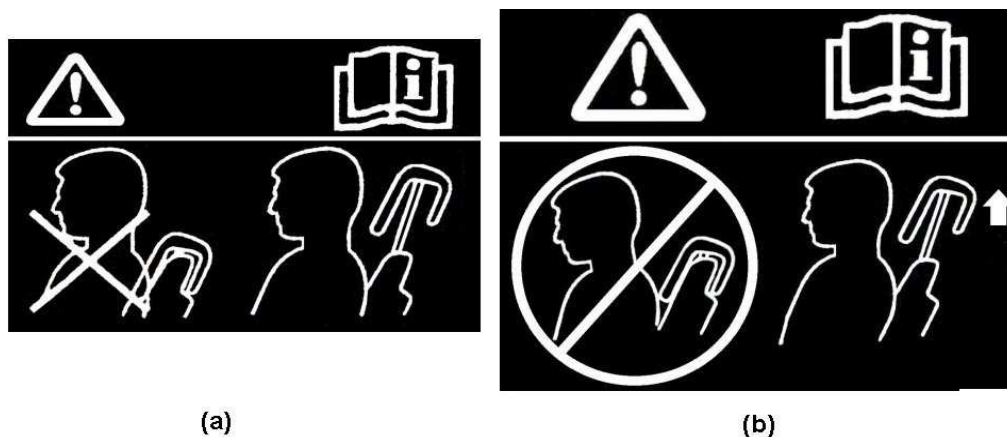

Figure 1

5.5. Removability of head restraints

The head restraints shall not be removable without a deliberate action distinct from any action necessary for upward head restraint adjustment.

6. TEST CONDITIONS

The test procedures described in the following annexes are to be performed using any or all of the following:

- 6.1. A full vehicle including at least the seat to be tested and all necessary seat and head restraint equipment.
- 6.2. A vehicle body in white including at least the seat to be tested and all necessary seat and head restraint equipment.
- 6.3. A seat equipped with its head restraint and all necessary attachment hardware, as well as all necessary equipment for the activation of dynamic head restraints.

ANNEX 1

MINIMUM HEIGHT MEASUREMENT TEST PROCEDURE

1. PURPOSE

The purpose of this test procedure is to demonstrate compliance with the minimum height requirements described in paragraph 5.1.1. of this regulation.

2. PROCEDURE FOR HEIGHT MEASUREMENT

Compliance with the requirements of paragraph 5.1.1. of this regulation is demonstrated by using the height measurement apparatus defined in paragraph 2.2. below.

The seat is adjusted such that its H-point coincides with the R- point; if the seat back is adjustable, it is set at the design seat back angle; both of these adjustments are in accordance with the requirements of paragraph 2.1. below. The height of the head restraint is the distance between point A and the intersection of lines AE and FG.

2.1. Relationship between the H-point and the R-point

When the seat is positioned in accordance to the manufacturer's specifications, the H-point, as defined by its coordinates, shall lie within a square of 50 mm side length with horizontal and vertical sides whose diagonals intersect at the R-point, and the actual torso angle is within 5 degrees of the design torso angle.

2.1.1. If these conditions are met, the R-point and the design torso angle are used to determine the height of the head restraints in accordance with this Annex.

2.1.2. If the H-point or the actual torso angle does not satisfy the requirements of paragraph 2.1., the H-point and the actual torso angle are determined twice more (three times in all). If the results of two of these three operations satisfy the requirements, the conditions of paragraph 2.1.1. shall apply.

2.1.3. If the results of at least two of the three operations described in paragraph 2.1.2. do not satisfy the requirements of paragraph 2.1. the centroid of the three measured points or the average of the three measured angles is used and be regarded as applicable in all cases where the R-point or the design torso angle is referred to in this Annex.

2.2. Height measuring apparatus

The height measurement apparatus consists of (see Figure 1-1):

2.2.1. A straight edge AE. The lower point A is placed at the R point location in accordance with paragraph 2.1. of this Annex. The line AE is parallel to the design torso angle.

- 2.2.2. A straight edge FG, perpendicular to the line AE and in contact with the top of the head restraint. The height of the head restraint is the distance between point A and the intersection of the lines AE and FG.
- 2.3. Height measurement for front outboard head restraints
- 2.3.1. If adjustable, adjust the top of the head restraint to the highest position and measure the height.
- If adjustable, adjust the top of the head restraint to the lowest position intended for normal use, other than any non-use position described in paragraph 5.4. of this regulation, and measure the height.
- 2.3.2. For front outboard head restraints that are prevented by the interior surface of the vehicle roofline from meeting the required height as specified in paragraph 5.1.1.2. of this regulation, the requirements of paragraph 5.1.1.4. of this regulation are assessed by the following procedure:
- 2.3.2.1. Adjust the head restraint to its maximum height and measure the clearance between the top of the head restraint and the interior surface of the roofline or the rear backlight, by attempting to pass a 25 ± 0.5 mm sphere between them. In the case of convertibles, the diameter of the sphere is 50 ± 0.5 mm.
- 2.3.2.2. Adjust the top of the head restraint to the lowest position of adjustment intended for normal use, other than any non-use position described in paragraph 5.4. of this regulation, and measure the height.
- 2.4. Height measurement for front centre and rear outboard head restraints
- 2.4.1. If adjustable, adjust the top of the head restraint to the lowest position of adjustment intended for normal use, other than any non-use position described in paragraph 5.4. of this regulation and measure the height.
- 2.4.2. For head restraints that are prevented by the interior surface of the vehicle roofline or rear backlight from meeting the required height as specified in paragraphs 5.1.1.3. or 5.1.1.5. of this regulation, the requirements of paragraphs 5.1.1.4. and 5.1.1.6. are assessed by the following procedure:
- 2.4.2.1. If adjustable, adjust the head restraint to its maximum height and measure the clearance between the top of the head restraint or the seat back at all seat back angles for intended use and the interior surface of the roofline or the rear backlight, by attempting to pass a 25 ± 0.5 mm sphere between them. In the case of convertibles, the diameter of the sphere is 50 ± 0.5 mm.

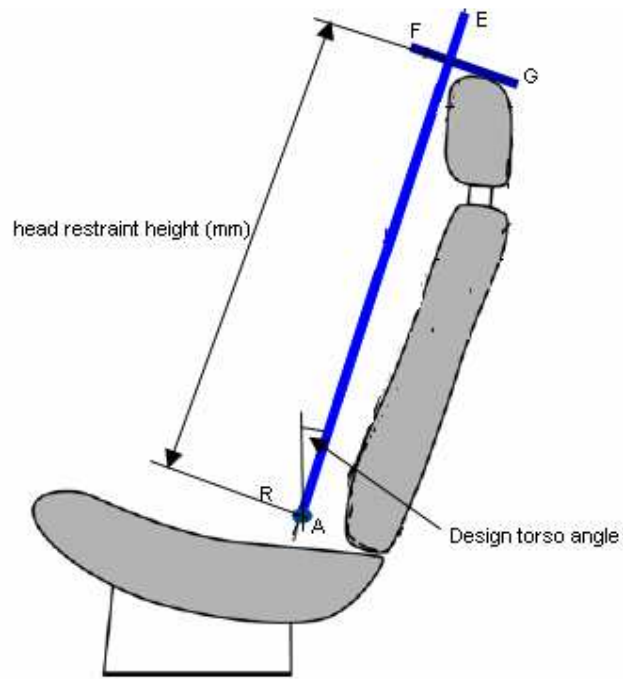

Figure 1-1

Annex 2

MINIMUM WIDTH MEASUREMENT TEST PROCEDURE

1. PURPOSE

The purpose of this test procedure is to demonstrate compliance with the minimum width requirements described in paragraph 5.1.2. of this regulation.

2. PROCEDURE FOR WIDTH MEASUREMENT

- 2.1. The seat is adjusted such that its H-point coincides with the R-point; if the seat back is adjustable, it is set at the design seat back angle; both these adjustments are in accordance with the requirements of paragraph 2.1. of Annex 1.
- 2.2. The plane S1 is a plane perpendicular to the reference line and situated 65 ± 3 mm below the top of the head restraint.
- 2.3. Planes P and P' are vertical longitudinal planes, tangential to each side of the head restraint to be measured.
- 2.4. Measure the distance L and L', measured in the plane S1 between the vertical longitudinal plane passing through the torso line and vertical longitudinal planes P and P'.

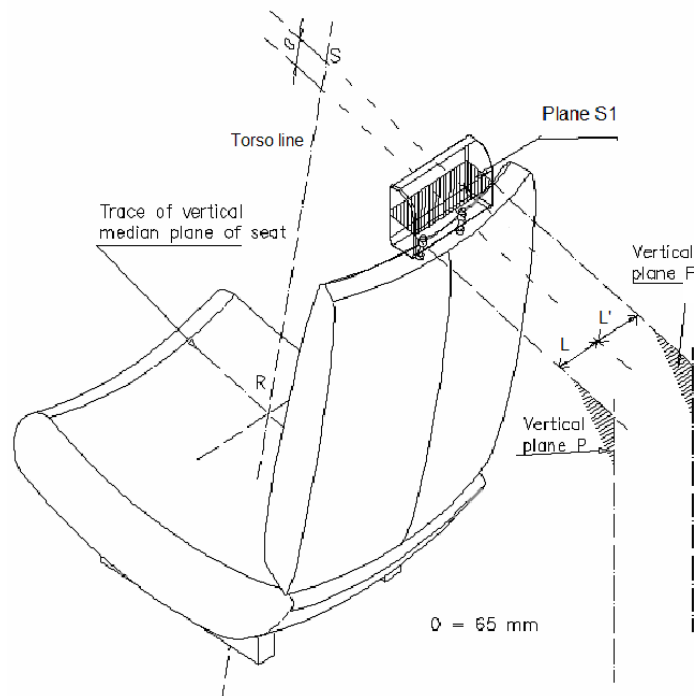

Figure 2-1

Annex 3

GAP MEASUREMENT TEST PROCEDURE

1. PURPOSE

The purpose of this test procedure is to evaluate any gaps within head restraints as well as gaps between the bottom of the head restraint and the top of the seat back, in accordance with the requirements of paragraphs 5.1.3. and 5.1.4. of this regulation.

Any gaps within the head restraint are measured using the sphere procedure described in paragraph 2. of this Annex.

Gaps between the bottom of the head restraint and the top of the seat back are measured using either the sphere procedure described in paragraphs 2.1. through 2.5. of this Annex, or, at the manufacturer option, using the linear procedure described in paragraph 3. of this Annex.

2. GAP MEASUREMENT USING A SPHERE

- 2.1. The seat is adjusted such that its H-point coincides with the R-point; if the seat back is adjustable, it is set at the design seat back angle; both these adjustments are in accordance with the requirements of paragraph 2.1. of Annex 1.
- 2.2. The head restraint is adjusted to its lowest height position and any backset position intended for occupant use.
- 2.3. The area of measurement is anywhere between two vertical longitudinal planes passing at 85 mm on either side of the torso line and above the top of the seat back.
- 2.4. Applying a load of no more than 5 N against the area of measurement specified in paragraph 2.3. above, place a 165 ± 2 mm diameter spherical head form against any gap such that at least two points of contact are made within the area.
- 2.5. Determine the gap dimension by measuring the straight line distance between the inner edges of the two furthest contact points, as shown in Figures 3-1 and 3-2.
- 2.6. For gaps within the head restraint, if the measurement determined in paragraph 2.5 of this Annex exceeds 60 mm, then in order to demonstrate compliance with the requirements of paragraph 5.1.3. of this regulation, the seat back displacement test procedure described in Annex 6 is performed, by applying to each gap, using a sphere of 165 mm in diameter, a force passing through the centre of gravity of the smallest of the sections of the gap, along transversal planes parallel to the torso line, and reproducing a moment of 373 Nm about the R point.

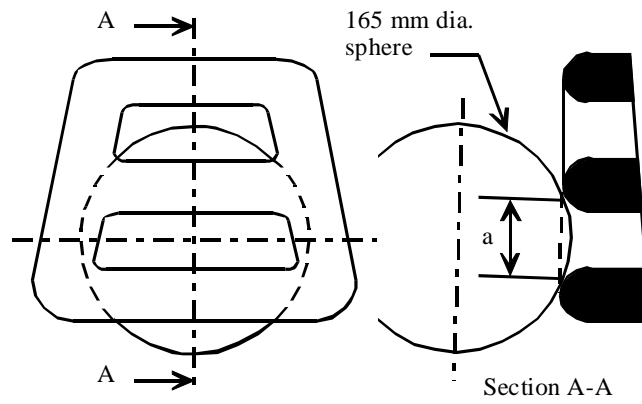

Figure 3-1 - Measurement of a vertical gap "a".

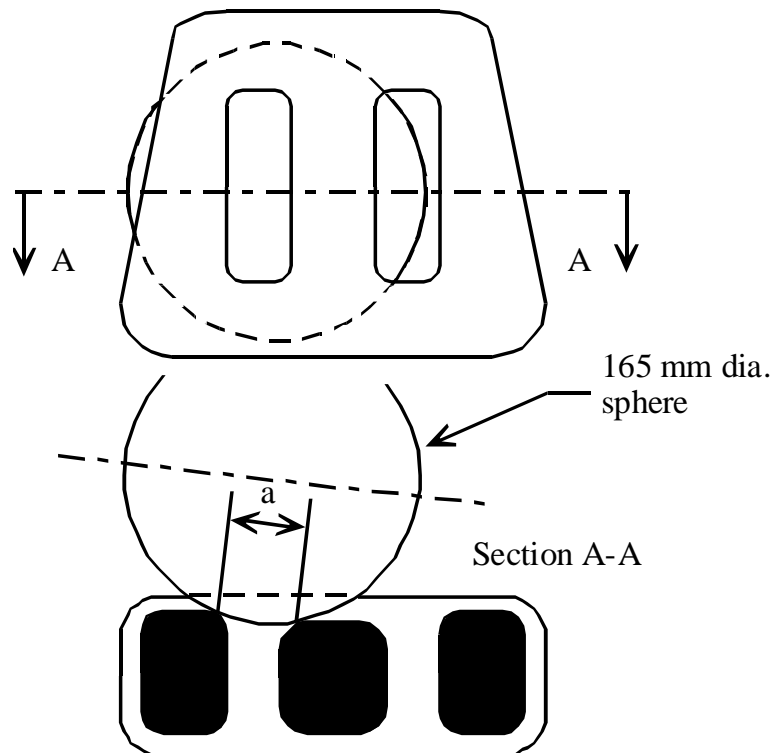

Figure 3-2 - Measurement of a horizontal gap "a".

3. LINEAR MEASUREMENT OF GAP

- 3.1. The seat is adjusted such that its H-point coincides with the R-point; if the seat back is adjustable, it is set at the design seat back angle; both these adjustments are in accordance with the requirements of paragraph 2.1. of Annex 1.
- 3.2. The head restraint is adjusted to its lowest height position and any backset position intended for occupant use.
- 3.3. The gap between the bottom of the head restraint and the top of the seat is measured as the perpendicular distance between two parallel planes, described as follows (see Figure 3-3).
 - 3.3.1. Each plane is perpendicular to the design torso line.
 - 3.3.2. One of the planes is tangent to the bottom of the head restraint.
 - 3.3.3. The other plane is tangent to the top of the seat back.

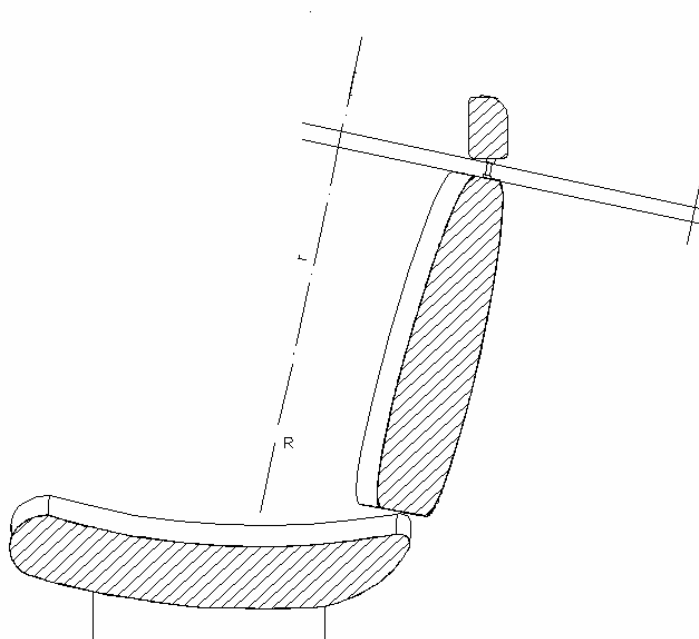

Figure 3-3

Annex 4

BACKSET MEASUREMENT TEST PROCEDURE USING THE HRMD METHOD

1. PURPOSE

Demonstrate compliance with paragraph 5.1.5.2. by measuring the backset using the H-point as the reference point.

2. PROCEDURE FOR BACKSET MEASUREMENT USING H-POINT AS THE REFERENCE POINT

Demonstrate compliance with paragraph 5.1.5.2. by measuring the backset of the head restraint using the three-dimensional H-point machine, defined in Annex 13, and the HRMD (Figure 4-1). This procedure uses the H-point as the reference point.

2.1. The test vehicle is levelled using the door sill (front to rear level) and centre luggage compartment (side to side level) as reference points.

2.2. The test vehicle is preconditioned at a temperature of $20\text{ }^{\circ}\text{C} \pm 10\text{ }^{\circ}\text{C}$ to ensure that the seat material reaches room temperature.

2.3. Remove the head room probe from the three-dimensional H-point machine and install the two washers (supplied with the HRMD) in the spaces remaining on the H-point pivot.

2.4. Set up the seat as described in Annex 12, paragraph 3.3. If the seat back is adjustable, it is set at an initial inclination position closest to design angle as measured by the three-dimensional H-point machine. If there is more than one inclination position closest to design angle, set the seat back inclination to the position closest to and rearward of the design angle.

2.5. Set up the H-point machine as described in Annex 12, paragraphs 3.4. through 3.10.

2.6. Confirm the H-point assembly is level, facing directly forward and located in the centreline of the vehicle seat. As necessary reposition the seat pan.

2.7. Install the right and left buttock weights. Install four of the torso weights used in Annex 12, paragraph 3.11., and the two larger HRMD chest weights; alternating left to right. The HRMD torso weights are installed last and with the flat side down. Maintain H-point machine level.

2.8. Confirm the actual torso angle is $\pm 1^{\circ}$ of the design torso angle by placing an inclinometer on the lower brace of the torso weight hangers. If the measured angle is outside this range, if possible adjust the seat back angle to be $\pm 1^{\circ}$ of the design seat back angle. If an adjustment is made, remove the buttock and torso weights and repeat

the steps contained in paragraphs 3.9. through 3.10. of Annex 12, along with steps as described in paragraphs 2.6. and 2.7. of this Annex until the actual torso angle is $\pm 1^\circ$ of the design seat back angle.

- 2.9. Perform the steps contained in paragraph 3.12. of Annex 12.
- 2.10. Attach the HRMD to the three-dimensional H-point machine.
- 2.11. Confirm the actual torso angle remained $\pm 1^\circ$ of the design seat back angle by placing an inclinometer on the lower brace of the torso weight hangers. If the actual torso angle is outside this range, if possible carefully adjust the seat back angle to be $\pm 1^\circ$ of the design seat back angle. If the legs and seat pan of the three-dimensional H-point machine move during this procedure, remove the HRMD, the buttock and torso weights, and repeat the steps contained in paragraphs 3.9. through 3.11. of Annex 12, along with steps as described in paragraphs 2.6. through 2.10. of this Annex until the actual torso angle is $\pm 1^\circ$ of the design seat back angle.
- 2.12. Level the HRMD and extend the sliding scale on the back of the head until it contacts the head restraint. Confirm that the scale is positioned laterally within 15 mm of the torso line and take the backset measurement.

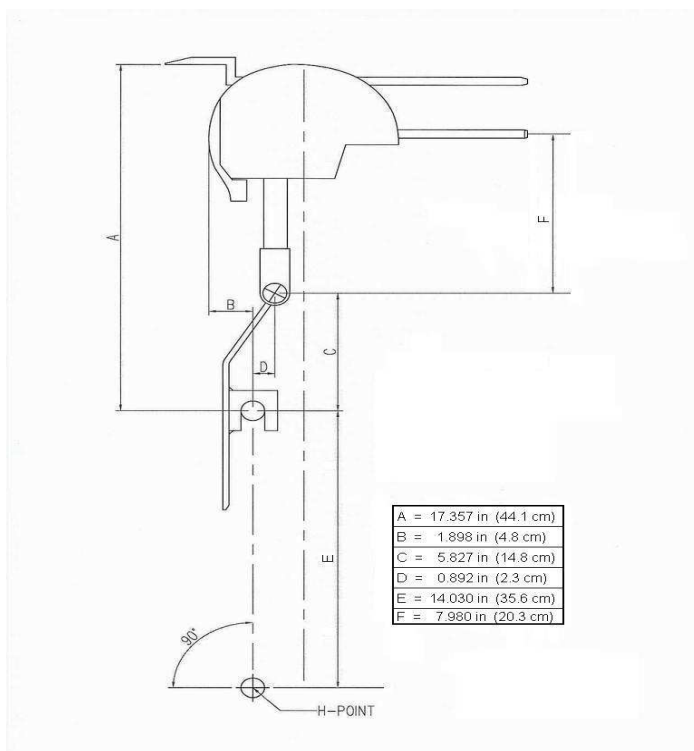

Figure 4-1

Annex 5

BACKSET MEASUREMENT TEST PROCEDURE USING THE R-POINT METHOD

1. PURPOSE

Demonstrate compliance with paragraph 5.1.5.2. by measuring the backset using the R-point as the reference point.

2. PROCEDURE FOR BACKSET MEASUREMENT USING R-POINT AS THE REFERENCE POINT

Demonstrate compliance with paragraph 5.1.5.2. by measuring the backset of the head restraint using the backset measurement apparatus defined in paragraph 2.1. of this Annex and the following procedures:

2.1. Backset measuring apparatus

The backset measurement apparatus consists of (see Figure 5-2):

2.1.1. A straight edge (lower arm) AB. The lower point A is placed at the R point location. Point B is located at a distance of 504.5 mm from the R point. The line AB is 2.6 degrees forward of the design torso angle.

2.1.2. A vertical straight edge (upper arm) BC. Point C is located at a distance of 203 mm vertically up from point B.

2.2. Adjust the seat such that its H-point coincides with the R-point, in accordance with the following requirements.

2.2.1. Relationship between the H-point and the R-point

When the seat is positioned in accordance to the manufacturer's specifications, the H-point, as defined by its co-ordinates, shall lie within a square of 50 mm side length with horizontal and vertical sides whose diagonals intersect at the R-point, and the actual torso angle is within 5 degree of the design torso angle.

2.2.2. If these conditions are met, the R-point and the design torso angle are used to demonstrate compliance with the provisions of paragraph 5.1.5.2. of this regulation.

2.2.3. If the H-point or the actual torso angle does not satisfy the requirements of paragraph 2.2.1., the H-point and the actual torso angle are determined twice more (three times in all). If the results of two of these three operations satisfy the requirements, the conditions of paragraph 2.2.2. shall apply.

2.2.4. If the results of at least two of the three operations described in paragraph 2.2.3. do not

satisfy the requirements of paragraph 2.2.1. the centroid of the three measured points or the average of the three measured angles is used and be regarded as applicable in all cases where the R-point or the design torso angle is referred to in this Annex.

- 2.3. Adjust the seat back to its design angle.
- 2.4. Adjust the front head restraint so that its top is at any height between and inclusive of 750 mm and 800 mm. If the lowest position of adjustment is above 800mm, adjust the head restraint to that lowest position of adjustment.
- 2.5. In the case of head restraint with adjustable backset, adjust the head restraint at the most rearward position, such that the backset is in the maximum position.
- 2.6. Establish point D on the head restraint, point D being the intersection of a line drawn from point C horizontally in the x-direction, with the front surface of the head restraint.
- 2.7. Measure the distance CD. The backset is the measured distance CD minus 71 mm.

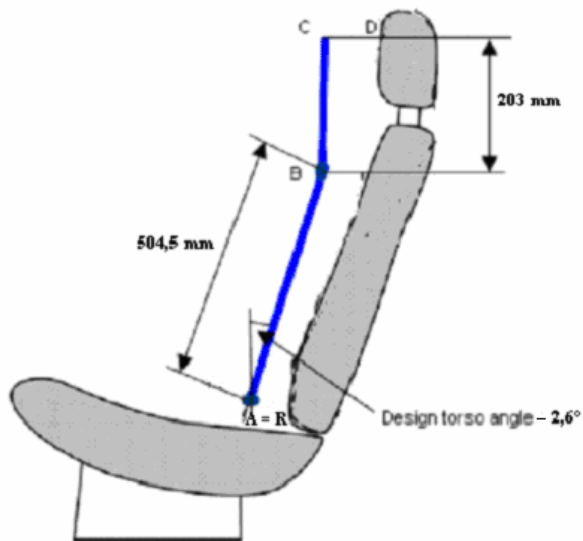

Figure 5-2

Annex 6

DISPLACEMENT, BACKSET RETENTION, AND STRENGTH TEST PROCEDURE

1. PURPOSE

Demonstrate compliance with the displacement requirements of paragraph 5.1.3. of this regulation with paragraph 2. of this Annex.

Demonstrate compliance with the displacement requirements of paragraph 5.2.3.3. of this regulation with paragraph 2. of this Annex.

Demonstrate compliance with the displacement and backset retention requirements of paragraph 5.2.3.2. of this regulation with paragraph 3. of this Annex.

Demonstrate compliance with the strength requirements of paragraph 5.2.4. of this regulation with paragraph 4. of this Annex.

2. PROCEDURE FOR DISPLACEMENT

The load vectors that generate moment on the head restraint are initially contained in a vertical plane parallel to the vertical longitudinal zero plane.

2.1. Seat set-up

If the seat back is adjustable, it is adjusted to a position specified by the vehicle manufacturer. If there is more than one inclination position closest to the position specified by the manufacturer, set the seat back inclination to the position closest to and rearward of the manufacturer specified position. If the head restraint position is independent of the seat back inclination position, compliance is determined at a seat back inclination position specified by the manufacturer. Adjust the head restraint to the highest position of vertical adjustment intended for occupant use. Adjust the head restraint to the rearmost (relative to the seat) position of horizontal adjustment backset position.

2.2. In the seat, place a test device having, when viewed laterally, the back pan dimensions and torso line (vertical centre line) of the three dimensional H-point machine, as specified in Annex 13, with the head room probe in the full back position.

2.3. Establish the displaced torso line by creating a rearward moment of 373 ± 7.5 Nm about the R-point by applying a force to the seat back through the back pan at the rate of 2.5 Nm/second to 37.3 Nm/second. The initial location on the back pan of the moment generating force vector has a height of $290 \text{ mm} \pm 13 \text{ mm}$. Apply the force vector normal to the torso line and maintain it within 2 degrees of a vertical plane parallel to the vehicle vertical longitudinal zero plane. Constrain the back pan to

rotate about the R-point. Rotate the force vector direction with the back pan.

- 2.4. Maintain the position of the back pan as established in paragraph 2.3. of this Annex. Using a 165 ± 2 mm diameter spherical head form, establish the head form initial reference position by applying, perpendicular to the displaced torso line, a rearward initial load at the seat centreline at a height 65 ± 3 mm below the top of the head restraint that will produce a 373 Nm moment about the R-point. After maintaining this moment for 5 seconds, measure the rearward displacement of the head form during the application of the load.
- 2.5. When determining the rearward displacement for head restraints at a gap greater than 60 mm in accordance with paragraph 5.1.3. of this regulation, the load of paragraph 2.4. of this Annex is applied through the centre of gravity of the smallest of the sections of the gap, along transversal planes parallel to the torso line.
- 2.6. If the presence of gaps prevents the application of the force, as described in paragraph 2.4. of this Annex at 65 ± 3 mm from the top of the head restraint, the distance may be reduced so that the axis of the force passes through the centre line of the frame element nearest to the gap.

3. PROCEDURES FOR BACKSET RETENTION AND DISPLACEMENT

- 3.1 If the seat back is adjustable, it is adjusted to a position specified by the vehicle manufacturer. If there is more than one inclination position closest to the position specified by the manufacturer, set the seat back inclination to the position closest to and rearward of the manufacturer specified position. If the head restraint position is independent of the seat back inclination position, compliance is determined at a seat back inclination position specified by the manufacturer. Adjust the head restraint to the highest position of vertical adjustment intended for occupant use.
- 3.2 Adjust the head restraint to any backset position.
- 3.3 In the seat, place a test device having the back pan dimensions and torso line (vertical centre line), when viewed laterally, with the head room probe in the full back position, of the three-dimensional H-point machine.
- 3.4 Establish the displaced torso line by creating a rearward moment of 373 ± 7.5 Nm about the R-point by applying a force to the seat back through the back pan at the rate between 2.5 Nm/second and 37.3 Nm/second. The initial location on the back pan of the moment generating force vector has a height of $290 \text{ mm} \pm 13 \text{ mm}$. Apply the force vector normal to the torso line and maintain it within 2 degrees of a vertical plane parallel to the vehicle vertical longitudinal zero plane. Constrain the back pan to rotate about the R-point. Rotate the force vector direction with the back pan.
- 3.5 Maintain the position of the back pan as established in paragraph 3.4. of this Annex. Using a 165 ± 2 mm diameter spherical head form, establish the head form initial

reference position by applying, perpendicular to the displaced torso line, a rearward initial load at the seat centreline at a height 65 ± 3 mm below the top of the head restraint that will produce a 37 Nm moment about the R-point. Measure the rearward displacement of the head form during the application of the load.

- 3.6. If the presence of gaps prevents the application of the forces, as described in paragraph 3.5. of this Annex at 65 ± 3 mm from the top of the head restraint, the distance may be reduced so that the axis of the force passes through the centre line of the frame element nearest to the gap.
- 3.7. Increase the initial load at the rate of 2.5 Nm/second to 37.3 Nm/second until a 373 Nm moment about the R-point is produced. Maintain the load level producing that moment for not less than 5 seconds and then measure the rearward displacement of the head form relative to the displaced torso line.
- 3.8. Reduce the load at the rate of 2.5 Nm/second to 37.3 Nm/second until 0 Nm. Wait 10 minutes. Re-load to 37 Nm about the R-point. While maintaining the load level producing that moment, measure the rearward displacement of the head form position with respect to its initial reference position.

4. STRENGTH

Increase the load specified in paragraph 2.6. or paragraph 3.8. of this Annex at the rate between 5 N/second and 200 N/second to at least 890 N and maintain the applied load for not less than 5 seconds.

Annex 7

ENERGY ABSORPTION TEST PROCEDURE

1. PURPOSE

Evaluate the energy absorption ability of the head restraint by demonstrating compliance with paragraph 5.2.1. of this regulation in accordance with this Annex.

2. SEAT SET-UP

The seat is either mounted in the vehicle or firmly secured to the test bench, as mounted in the vehicle with the attachment parts provided by the manufacturer, so as to remain stationary when the impact is applied. The seat-back, if adjustable, is locked in the design position specified by the vehicle manufacturer. If the seat is fitted with a head restraint, the head restraint is mounted on the seat-back as in the vehicle. Where the head restraint is separate, it is secured to the part of the vehicle structure to which it is normally attached.

3. PROCEDURES FOR ENERGY ABSORPTION

The adjustable head restraints are measured in any height and backset position of adjustment.

3.1. Test equipment

3.1.1. Use an impactor with a semispherical head form of a 165 ± 2 mm diameter. The head form and associated base have a combined mass such that at a speed of not more than 24.1 km/h at the time of impact an energy of 152 Joule will be reached.

3.1.2. Instrument the impactor with an acceleration sensing device whose output is recorded in a data channel that conforms to the requirements for a 600 Hz channel class filter as specified in ISO Standard 6487 (2002). The axis of the acceleration-sensing device coincides with the geometric center of the head form and the direction of impact. As an alternative the impactor can be equipped with 2 accelerometers sensing in the direction of impact and placed symmetrically in comparison to the geometric centre of the spherical head form. In this case the deceleration rate is taken as the simultaneous average of the readings on the two accelerometers.

3.2. Accuracy of the test equipment

The recording instrument used is such that measurements can be made with the following degrees of accuracy:

3.2.1. Acceleration:

Accuracy = + 5 per cent of the actual value;

Cross-axis sensitivity = < 5 per cent of the lowest point on the scale.

3.2.2. Speed:

Accuracy: + 2.5 per cent of the actual value;

Sensitivity: 0.5 km/h.

3.2.3. Time recording:

The instrumentation shall enable the action to be recorded throughout its duration and readings to be made to within one one-thousandth of a second; the beginning of the impact at the moment of first contact between the head form and the item being tested is detected on the recordings used for analyzing the test.

3.3. Test procedure

3.3.1. Propel the impactor toward the head restraint. At the time of impact, the longitudinal axis of the impactor is within ± 2 degrees of being horizontal and parallel to the vehicle longitudinal axis and the impactor speed is not more than 24.1 km/h.

3.3.2. Impact the front surface of the head restraint at any point with a height greater than 635 mm from the R-point and within a distance of the head restraint vertical centre line of 70 mm and measure the acceleration.

Annex 8

HEIGHT RETENTION TEST PROCEDURE

1. Purpose

Demonstrate compliance with the height retention requirements of paragraph 5.2.2. of this regulation in accordance with this Annex.

1. Procedures for height retention

2.1. Seat set-up

Adjust the adjustable head restraint so that its top is at any of the following height positions at any backset position:

2.1.1. For front outboard designated seating positions:

2.1.1.1. The highest position; and

2.1.1.2. Not less than, but closest to 800 mm

2.1.2. For rear outboard and front centre designated seating positions

2.1.2.1. The highest position; and

2.1.2.2. Not less than, but closest to 750 mm.

2.1.3. For rear centre designated seating position

2.1.3.1. The highest position; and

2.1.3.2. Not less than, but closest to 700 mm.

2.2. Orient a cylindrical test device having a 165 ± 2 mm diameter in plane view (perpendicular to the axis of revolution), and a 152 mm length in profile (through the axis of revolution), such that the axis of the revolution is horizontal and in the longitudinal vertical plane through the vertical longitudinal zero plane of the head restraint. Position the midpoint of the bottom surface of the cylinder in contact with the head restraint.

2.3. Establish initial reference position by applying a vertical downward load of 50 ± 1 N at a rate of 250 ± 50 N/minute. Determine the reference position after 5 seconds at this load. Mark an initial reference position for the head restraint.

2.4. Measure the vertical distance between the lowest point on the underside of the head

restraint and the top of the seat back. (see paragraph 2.9. of this Annex)

- 2.5. Increase the load at the rate of 250 ± 50 N/minute to at least 500 N and maintain this load for not less than 5 seconds.
- 2.6. Reduce the load at a rate of 250 ± 50 N/m until the load is completely removed. Maintain this condition for no more than two minutes. Increase the load at a rate of 250 ± 50 N/minute to 50 ± 1 N and, after 5 seconds at this load, determine the position of the cylindrical device with respect to its initial reference position.
- 2.7. Repeat the measurement of the vertical distance measured between the lowest point on the underside of the head restraint and the top of the seat back. (see paragraph 2.9. of this Annex)
- 2.8. Compare the measurements from paragraphs 2.4. and 2.7. of this Annex. The difference is the measurement required to comply with paragraph 5.2.2. of this regulation.
- 2.9. If the design of the head restraint is such that it is not possible to measure to the top of the seat then the vertical measurement is taken by marking a horizontal line across the front of the seat back at least 25 mm below the lowest point of the head restraint and the measurement is taken from this line to the underside of the head restraint.

Annex 9

DYNAMIC PERFORMANCE TEST PROCEDURE

1. PURPOSE

Demonstrate compliance with paragraph 5.3. in accordance with this Annex, using a 50th percentile male Hybrid III test dummy.

2. TEST EQUIPMENT

2.1. An acceleration or deceleration test sled

2.2. 50th percentile male test dummy

2.2.1. Hybrid III

2.2.1.1. Three accelerometers are in the head cavity to measure orthogonal accelerations at the centre of gravity of the head assembly. The three accelerometers are mounted in an orthogonal array, and the intersection of the planes containing the sensitivity axis of the three sensors will be the origin of the array.

2.2.3. Equipment for measuring the head to torso angle.

2.2.4. Equipment for measuring and recording sled accelerations.

3. PROCEDURES FOR TEST SET-UP

3.1. Mount the vehicle on a dynamic test platform so that the vertical longitudinal zero plane of the vehicle is parallel to the direction of the test platform travel and so that movement between the base of the vehicle and the test platform is prevented. Instrument the platform with an accelerometer and data processing system. Position the accelerometer sensitive axis parallel to the direction of test platform travel.

3.2. Remove the tires, wheels, fluids, and all unsecured components. Rigidly secure the engine, transmission, axles, exhaust system, vehicle frame and any other vehicle component necessary to assure that all points on the acceleration vs. time plot measured by an accelerometer on the dynamic test platform fall within the corridor described in Figure 9-1 and Table 9-1.

3.3. Place any moveable windows in the fully open position.

3.4. Seat Adjustment

3.4.1. At each designated seating position, if the seat back is adjustable, it is set at an initial inclination position closest to 25 degrees from the vertical, as measured by the three-

dimensional H-point machine, as specified in Annex 13. If there is more than one inclination position closest to 25 degrees from the vertical, set the seat back inclination to the position closest to and rearward of 25 degrees.

- 3.4.2. Using any control that primarily moves the entire seat vertically, place the seat in the lowest position. Using any control that primarily moves the entire seat in the fore and aft directions, place the seat midway between the forwardmost and rearmost position. If an adjustment position does not exist midway between the forwardmost and rearmost positions, the closest adjustment position to the rear of the midpoint is used.
- 3.4.3. If the seat cushion adjusts independently of the seat back, position the seat cushion such that the highest H-point position is achieved with respect to the seat back, as measured by three-dimensional H-point machine as specified in Annex 13. If the specified position of the H-point can be achieved with a range of seat cushion inclination angles, adjust the seat inclination such that the most forward part of the seat cushion is at its lowest position with respect to the most rearward part.
- 3.4.4. If the head restraint is adjustable, adjust the top of the head restraint to a position midway between the lowest position of adjustment and the highest position of adjustment. If an adjustment position midway between the lowest and the highest position does not exist, adjust the head restraint to a position below and nearest to midway between the lowest position of adjustment and the highest position of adjustment.
- 3.4.5. Adjustable lumbar supports are positioned so that the lumbar support is in its lowest retracted or deflated position.
- 3.5. Seat Belt Adjustment

Prior to placing the seat belt around the test dummy, fully extend the webbing from the seat belt retractor(s) and release it three times to remove slack. If an upper adjustable seat belt turning loop (adjustable seat belt D-ring anchorage) exists, place it in the adjustment position closest to the mid-position. If an adjustment position does not exist midway between the highest and lowest position, the closest adjustment position above the midpoint is used.

- 3.6. Dress and adjust each test dummy as follows:

Each test dummy is clothed in a form fitting cotton stretch short sleeve shirt with above-the-elbow sleeves and above-the-knee length pants. The mass of the shirt or pants shall not exceed 0.06 kg each. Each foot of the test dummy is equipped with a size 11XW shoe whose mass is 0.51 ± 0.09 kg. Limb joints are set at 1g, barely restraining the weight of the limb when extended horizontally. Leg joints are adjusted with the torso in the supine position.

3.7. Hybrid III Test dummy positioning procedure

Place a test dummy at each designated seating position equipped with a head restraint.

3.7.1. Head

The transverse instrumentation platform of the head is level within 1/2 degree. To level the head of the test dummy, the following sequence is followed. First, adjust the position of the H-point ^{1/} to level the transverse instrumentation platform of the head of the test dummy. If the transverse instrumentation platform of the head is still not level, then adjust the pelvic angle of the test dummy. If the transverse instrumentation platform of the head is still not level, then adjust the neck bracket of the dummy the minimum amount necessary from the non-adjusted "0" setting to ensure that the transverse instrumentation platform of the head is horizontal within 1/2 degree. The test dummy remains within the limits specified in ^{1/} after any adjustment of the neck bracket.

3.7.2. Upper arms and hands

Position each test dummy as specified below:

3.7.2.1. The driver's upper arms shall be adjacent to the torso with the centre lines as close to a vertical plane as possible.

3.7.2.2. The passenger's upper arms are in contact with the seat back and the sides of the torso.

3.7.2.3. The palms of the drivers test dummy are in contact with the outer part of the steering wheel rim at the rim's horizontal centre line. The thumbs are over the steering wheel rim and are lightly taped to the steering wheel rim so that if the hand of the test dummy is pushed upward by a force of not less than 0.91 kg and not more than 2.27 kg, the tape shall release the hand from the steering wheel rim.

3.7.2.4. The palms of the passenger test dummy are in contact with the outside of the thigh. The little finger is in contact with the seat cushion.

3.7.3. Upper Torso

Position each test dummy such that the upper torso rests against the seat back. The

^{1/} The H-points of the driver and passenger test dummies shall coincide within 12.5 mm in the vertical dimension and 12.5 mm in the horizontal dimension of a point 6.25 mm below the position of the H-point determined by using the equipment and procedures specified in except that the length of the lower leg and thigh segments of the H-point machine shall be adjusted to 414 mm and 401 mm, respectively.

midsagittal plane of the dummy is aligned within 15 mm of the head restraint centreline. If the midsagittal plane of the dummy cannot be aligned within 15 mm of the head restraint centreline then align the midsagittal plane of the dummy as close as possible to the head restraint centreline.

3.7.4. Lower Torso

The H-points of the driver and passenger test dummies shall coincide within 12.5 mm in the vertical dimension and 12.5 mm in the horizontal dimension of a point 6.25 mm below the position of the H-point determined by the manikin defined in Annexes 12 and 13.

3.7.5. Pelvic Angle

As determined using the pelvic angle gage which is inserted into the H-point gauging hole of the dummy, the angle measured from the horizontal on the 76 mm flat surface of the gage is 22.5 ± 2.5 degrees.

3.7.6. Legs

Position each test dummy as follows:

The upper legs of the driver and passenger test dummies shall rest against the seat cushion to the extent permitted by placement of the feet. The initial distance between the outboard knee clevis flange surfaces is 269 mm. To the extent practicable, the left leg of the driver dummy and both legs of the passenger dummy are in vertical longitudinal planes. To the extent practicable, the right leg of the driver dummy is in a vertical plane. Final adjustment to accommodate the placement of feet in various passenger compartment configurations is permitted.

3.7.7. Feet

3.7.7.1. Driver's position

3.7.7.1.1. If the vehicle has an adjustable acceleration pedal, adjust it to the full forward position. Rest the right foot of the test dummy on the undepressed accelerator pedal with the rearmost point of the heel on the floor pan in the plane of the pedal. If the foot cannot be placed on the accelerator pedal, set it initially perpendicular to the lowest leg and then place it as far forward as possible in the direction of the pedal centreline with the rearmost point of the heel resting on the floor pan. If the vehicle has an adjustable accelerator pedal and the right foot is not touching the accelerator pedal when positioned as above, move the pedal rearward until it touches the right foot. If the accelerator pedal still does not touch the foot in the full rearward position, leave the pedal in that position.

3.7.7.1.2. Place the left foot on the toeboard with the rearmost point of the heel resting on the

floor pan as close as possible to the point of intersection of the planes described by the toeboard and the floor pan and not on the wheelwell projection. If the foot cannot be positioned on the toeboard, set it initially perpendicular to the lower leg and place it as far forward as possible with the heel resting on the floor pan. If necessary to avoid contact with the vehicle's brake or clutch pedal, rotate the test dummy's left foot about the lower leg. If there is still pedal interference, rotate the left leg outboard about the hip the minimum distance necessary to avoid the pedal interference. For vehicles with a foot rest that does not elevate the left foot above the level of the right foot, place the left foot on the foot rest so that the upper and lower leg centrelines fall in a vertical plane.

3.7.7.2. Front Passenger's position

3.7.7.2.1. Vehicles with a flat floor pan/toeboard

Place the right and left feet on the vehicle's toeboard with the heels resting on the floor pan as close as possible to the intersection point with the toeboard. If the feet cannot be placed flat on the toeboard, set them perpendicular to the lower leg centrelines and place them as far forward as possible with the heels resting on the floor pan.

3.7.7.2.2. Vehicles with wheelhouse projections in passenger compartment

Place the right and left feet in the well of the floor pan/toeboard and not on the wheelhouse projection. If the feet cannot be placed flat on the toeboard, initially set them perpendicular to the lower leg centrelines and then place them as far forward as possible with the heels resting on the floor pan.

3.7.7.3. Rear Passenger's position

Position each test dummy as specified in paragraph 2.7.7.2. of this Annex, except that feet of the test dummy are placed flat on the floorpan and beneath the front seat as far forward as possible without front seat interference. If necessary, the distance between the knees can be changed in order to place the feet beneath the seat.

3.8. All tests specified by this standard are conducted at an ambient temperature of 18 to 28 °C.

3.9 All tests are performed with the ignition "on."

4. TEST PROCEDURE.

4.1. Accelerate or decelerate the dynamic test platform to reach a delta V of 17.3 ± 0.6 km/h. All of the points on the acceleration vs. time curve fall within the corridor described in Figure 9-1 and Table 9-1 when filtered to channel class 60, as specified in the SAE Recommended Practice J211/1 (revision March 1995). Measure the

maximum rearward angular displacement.

- 4.2. Calculate the angular displacement from the output of instrumentation placed in the torso and head of the test dummy and an algorithm capable of determining the relative angular displacement to within one degree and conforming to the requirements of a 600 Hz channel class, as specified in SAE Recommended Practice J211/1, (revision March 1995). No data generated after 200 ms from the beginning of the forward acceleration are used in determining angular displacement of the head with respect to the torso.
- 4.3. Calculate the HIC15 from the output of instrumentation placed in the head of the test dummy, using the equation in paragraph 5.3.2.3. of this regulation and conforming to the requirements for a 1,000 Hz channel class as specified in SAE Recommended Practice J211/1 (revision March 1995). No data generated after 200 ms from the beginning of the forward acceleration are used in determining HIC.

Reference Point	Time (ms)	Acceleration (m/s^2)
A	0	10
B	28	94
C	60	94
D	92	0
E	4	0
F	38.5	80
G	49.5	80
H	84	0

Table 9-1 – Sled pulse corridor reference point locations.

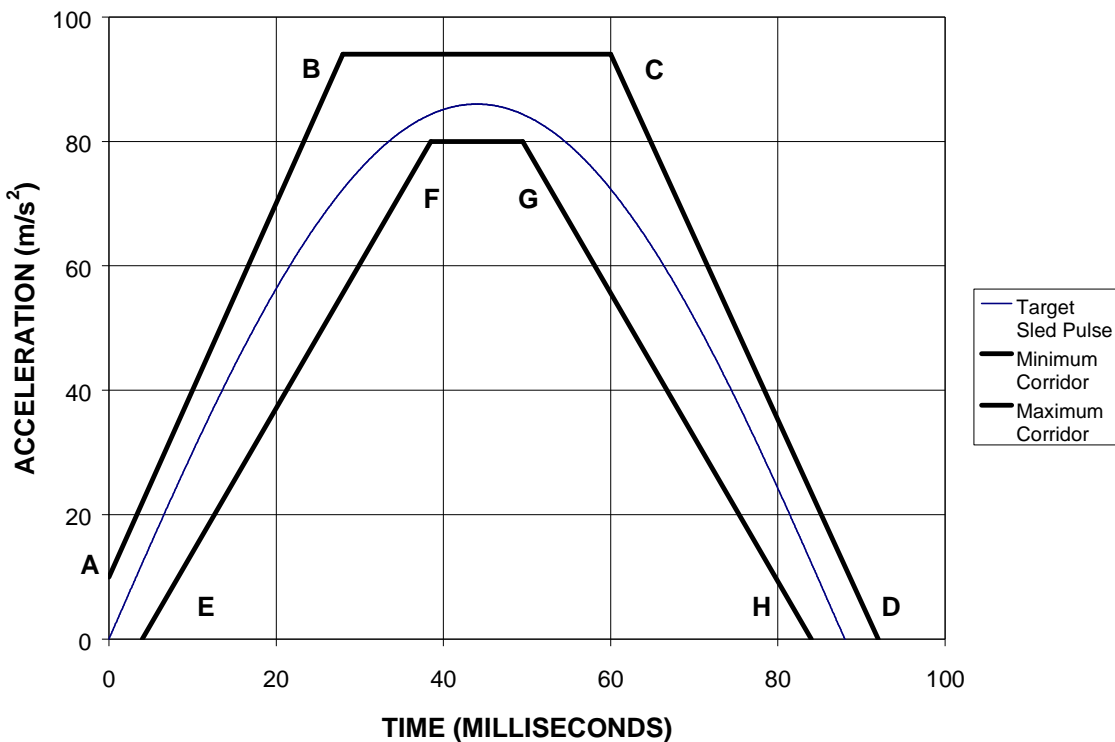

Figure 9-1 – Sled pulse acceleration corridor.

The target acceleration with time expressed in milliseconds is $a = 86 \sin(\pi t/88) \text{ m/s}^2$, for $V = 17.3 \pm 0.6 \text{ km/h}$. The time zero for the test is defined by the point when the sled acceleration achieves 2.5 m/s^2 ($0.25g$'s).

Annex 10

NON-USE POSITION TEST PROCEDURE

1. PURPOSE

Procedures for folding or retracting head restraints in all designated seating positions equipped with head restraints, except the driver's designated seating position.

2. PROCEDURES TO TEST AUTOMATIC RETURN HEAD RESTRAINTS

Demonstrate compliance with paragraph 5.4.4.1, with the ignition "on", and using a 5th percentile female Hybrid III test dummy^{1/} in accordance with paragraph 2.1. of this Annex, or a human surrogate in accordance with paragraph 2.2. of this Annex. Compliance is determined at a temperature of 18 to 28 °C.

2.1. 5th percentile Hybrid III Dummy

2.1.1. Position the test dummy in the seat such that the dummy's midsagittal plane is aligned within 15 mm of the seating position centreline and is parallel to a vertical plane parallel to the vehicle vertical longitudinal zero plane.

2.1.2. Hold the dummy's thighs down and push rearward on the upper torso to maximize the dummy's pelvic angle.

2.1.3. Place the legs as close as possible to 90 degrees to the thighs. Push rearward on the dummy's knees to force the pelvis into the seat so there is no gap between the pelvis and the seat back or until contact occurs between the back of the dummy's calves and the front of the seat cushion such that the angle between the dummy's thighs and legs begins to change.

2.1.4. Note the position of the head restraint. Remove the dummy from the seat. If the head restraint returns to a retracted position upon removal of the dummy, manually place it in the noted position. Determine compliance with the height requirements of paragraph 5.1.1. by using the test procedures of Annex 1.

2.2. Human surrogate

^{1/} The technical specifications and detailed drawings of Hybrid III dummy, corresponding to the principal dimensions of a 5th percentile female of the United States of America, and the specifications for its adjustment for this test are deposited with the Secretary General of the United Nations and may be consulted on request at the secretariat of the United Nations Economic Commission for Europe, Palais des Nations, Geneva, Switzerland.

A human being who weighs between 47 and 51 kg, and who is between 140 and 150 cm tall may be used. The human surrogate is dressed in a cotton T-shirt, full length cotton trousers, and sneakers. Specified weights and heights include clothing.

- 2.2.1. Position the human in the centre of the seat with the pelvis touching the seat back and the back against the seat back.
- 2.2.2. Verify the human's midsagittal plane is vertical and within ± 15 mm of the seating position centreline.
- 2.2.3. Verify the transverse distance between the centres of the front of the knees is 160 to 170 mm. Centre the knee separation with respect to the seat centreline.
- 2.2.4. If needed, extend the legs until the feet do not contact the floor pan. The thighs are resting on the seat cushion.
- 2.2.5. If the human contacts the interior move the seat rearward until a maximum clearance of 5 mm is achieved or the seat is in the closest detent position which does not cause human contact.
- 2.2.6. Passenger foot positioning.
 - 2.2.6.1. Place feet flat on the toe board, or
 - 2.2.6.2. If the feet cannot be placed flat on the toe board, the feet are perpendicular to the lower leg, and the heel is as far forward as possible and resting on the floor pan, or
 - 2.2.6.3. If the heels do not touch the floor pan, the legs are vertical and the feet parallel to the floor pan.
- 2.2.7. Passenger arm/hand positioning.
 - 2.2.7.1. Place the human's upper arms adjacent to the torso with the arm centrelines as close to a vertical longitudinal plane as possible.
 - 2.2.7.2. Place the palms of the human in contact with the outer part of the thighs.
 - 2.2.7.3. Place the little fingers in contact with the seat cushion.
- 2.3. Start the vehicle engine or place the ignition in the "on" position, whichever will turn on the suppression system, and close all vehicle doors. Note the position of the head restraint. Remove the human from the seat. If the head restraint returns to a retracted position upon removal of the human, manually place it in the noted position. Determine compliance with the height requirements of paragraph 5.1.1. by using the test procedures of Annex 1.

2.4. Return the ignition switch to the "off" position.

3. 60° ROTATION EVALUATION

Procedures for the rear and front centre designated seating positions to demonstrate compliance with paragraph 5.4.4.2.

3.1. Place the head restraint in any position meeting the requirements of paragraph 5.1.1.3. or paragraph 5.1.1.5. of the regulation;

3.1.1. Mark a line on the head restraint with one end at the point of rotation. Measure the angle or range of angles of the head restraint reference line as projected onto a vertical longitudinal vehicle plane;

3.1.2. Fold or retract the head restraint to a position in which its minimum height is less than that specified in paragraph 5.1.1.3. or paragraph 5.1.1.5.;

3.1.3. Determine the minimum change in the head restraint reference line angle as projected onto a vertical longitudinal vehicle plane from the angle or range of angles measured in paragraph 3.1.1. of this Annex.

4. DISCOMFORT METRIC

Procedures for the rear and front centre designated seating positions to demonstrate compliance with paragraph 5.4.4.3. of this regulation.

4.1. The H_{LE} and S dimensions are defined in Figure 10-1. Figure 10-1 is a vertical fore-aft plane passing through the R-point (i.e. at the mid point of the designated seating position) intersecting the seat cushion, seat back and the head restraint.

4.2. Adjust the head restraint to the non-use position.

4.2.1. H_{LE} is the distance from the R-point to the lower edge of the head restraint measured along the torso line.

4.2.2. S is the maximum thickness of the head restraint (as determined within 25 mm of the head restraint lower edge) measured perpendicular to the torso line between T_H and T_S from line P.

4.2.3. P is a line parallel to the torso line which intersects the head restraint at T_S

4.2.4. T_H is the line perpendicular to the torso line and tangent to the lower edge of the head restraint.

4.2.5. T_S is the line parallel to and 25 mm from T_H .

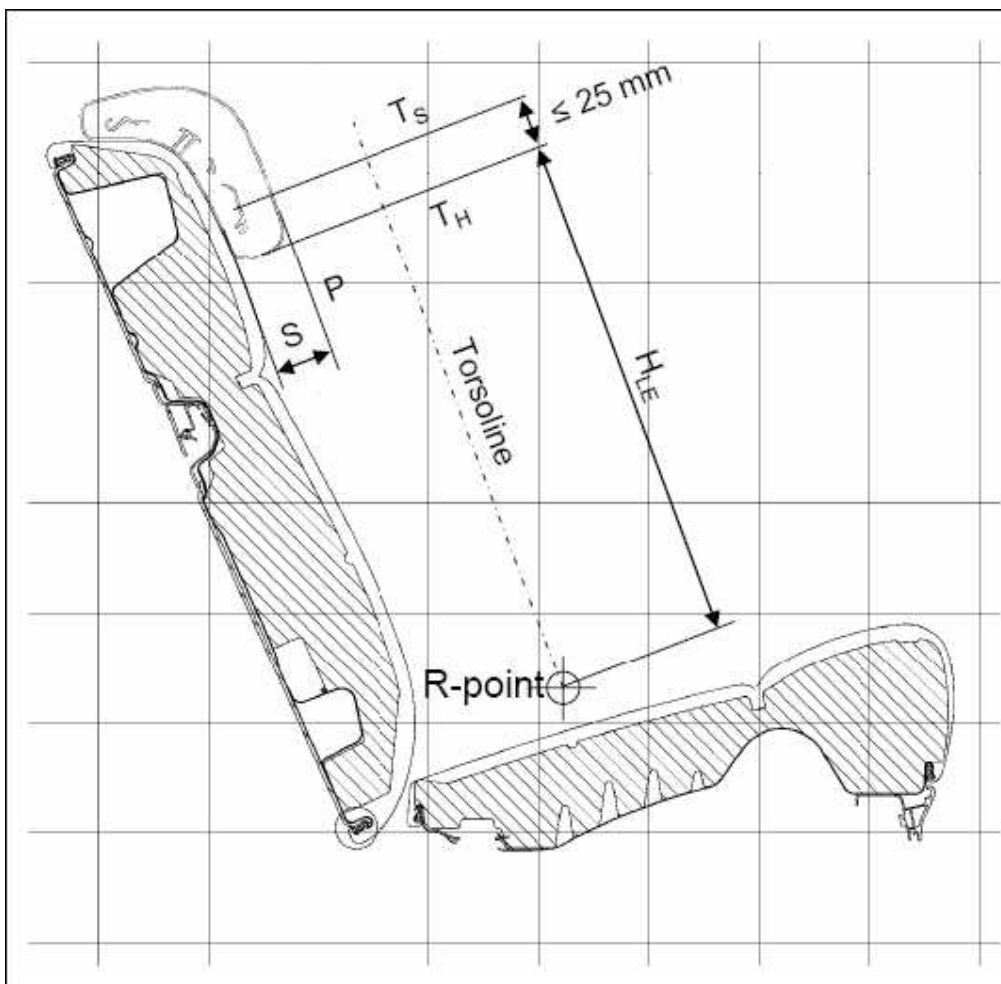

Figure 10-1

5. 10° TORSO LINE CHANGE

Procedures for the rear and front centre designated seating positions to demonstrate compliance with paragraph 5.4.4.4.

- 5.1. Place the head restraint into any position meeting the requirements of paragraph 5.1.1 of this regulation;
- 5.2. Measure the torso line angle with the three dimensional H-point machine defined in Annex 13;
- 5.3. Fold or retract the head restraint to any position in which its minimum height is less than that specified in paragraph 5.1.1. of this regulation or in which its backset is more than that specified in paragraph 5.1.5. of this regulation; and
- 5.4. Again measure the torso line angle.

Annex 11

THREE-DIMENSIONAL REFERENCE SYSTEM

1. The three dimensional reference system is defined by three orthogonal planes established by the vehicle manufacturer (see Figure 11-1)^{1/}
2. The vehicle measuring attitude is established by positioning the vehicle on the supporting surface such that the co ordinates of the fiducial marks correspond to the values indicated by the manufacturer.
3. The coordinates of the "R" point and the "H" point are established in relation to the fiducial marks defined by the vehicle manufacturer.

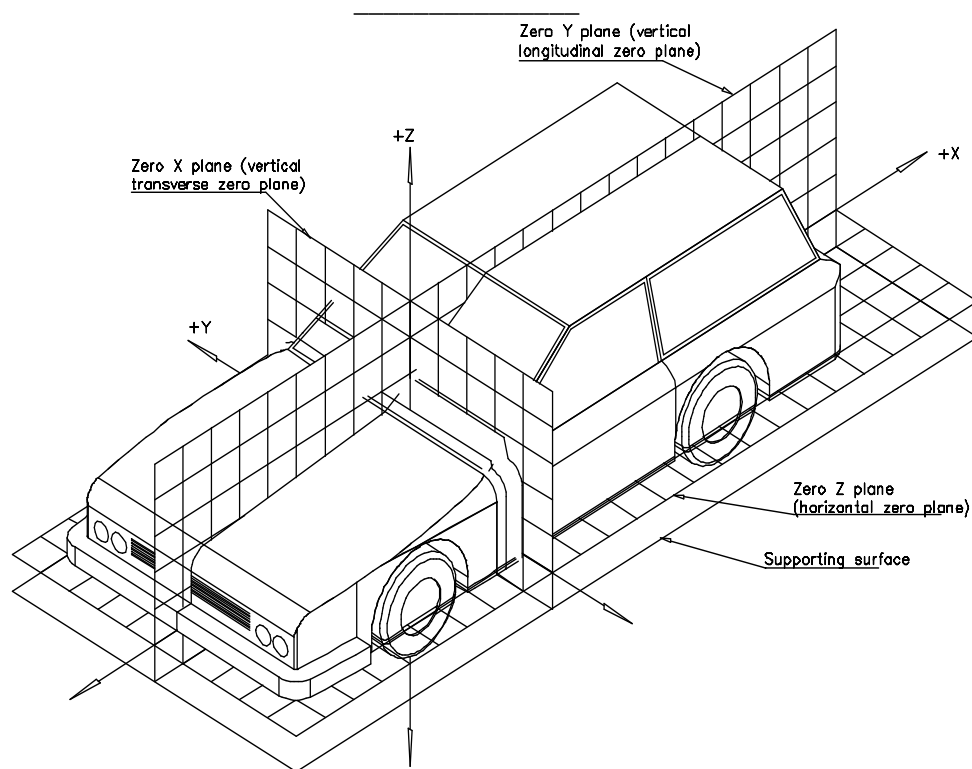

Figure 11-1 - Three-dimensional reference system

^{1/} The reference system corresponds to ISO standard 4130: 1978.

Annex 12

PROCEDURE FOR VALIDATION OF THE H-POINT AND R-POINT RELATIONSHIP FOR SEATING POSITIONS IN MOTOR VEHICLES

1. PURPOSE

The procedure described in this Annex is used to establish the H-point location and the actual torso angle for one or several seating positions in a motor vehicle and to verify the relationship of measured data to design specifications given by the vehicle manufacturer.

2. DEFINITIONS

For the purposes of this Annex:

- 2.1. "Reference data" means one or several of the following characteristics of a seating position:
 - 2.1.1. the H- point and the R-point and their relationship,
 - 2.1.2. the actual torso angle and the design torso angle and their relationship.
- 2.2. "Three-dimensional H-point machine (3-D H machine)" means the device used for the determination of H-points and actual torso angles. This device is described in Annex 13;
- 2.3. "Centre plane of occupant (C/LO)" means the median plane of the 3-D H machine positioned in each designated seating position; it is represented by the coordinate of the H-point on the "Y" axis. For individual seats, the centre plane of the seat coincides with the centre plane of the occupant. For other seats, the centre plane of the occupant is specified by the manufacturer;
- 2.4. "Three-dimensional reference system" means a system as described in Annex 11;
- 2.5. "Fiducial marks" are physical points (holes, surfaces, marks or indentations) on the vehicle body as defined by the manufacturer;
- 2.6. "Vehicle measuring attitude" means the position of the vehicle as defined by the coordinates of fiducial marks in the three-dimensional reference system.

3. PROCEDURE FOR H-POINT AND ACTUAL TORSO ANGLE DETERMINATION

- 3.1. The vehicle is preconditioned at a temperature of $20\text{ }^{\circ}\text{C} \pm 10\text{ }^{\circ}\text{C}$ to ensure that the seat material reaches room temperature.
- 3.2. The vehicle is at the measuring attitude defined in paragraph 2.6. of this Annex.
- 3.3. The seat, if it is adjustable, is adjusted first to the rearmost normal driving position, as indicated by the vehicle manufacturer, taking into consideration only the longitudinal adjustment of the seat, excluding seat travel used for purposes other than normal driving positions. Where other modes of seat adjustment exist (vertical, angular, seat back, etc.) these will be then adjusted to the position specified by the vehicle manufacturer. For suspension seats, the vertical position is rigidly fixed corresponding to a normal driving position as specified by the manufacturer.
- 3.4. The area of the seating position contacted by the 3-D H machine is covered by a muslin cotton, of sufficient size and appropriate texture, described as a plain cotton fabric having 18.9 threads per cm^2 and weighing 0.228 kg/m^2 or knitted or non woven fabric having equivalent characteristics.

If the test is run on a seat outside the vehicle, the floor on which the seat is placed shall have the same essential characteristics (tilt angle, height difference with a seat mounting, surface texture, etc.) as the floor of the vehicle in which the seat is intended to be used.

- 3.5. Place the seat and back assembly of the 3-D H machine so that the centre plane of the occupant (C/LO) coincides with the centre plane of the 3-D H machine. At the manufacturer's request, the 3-D H machine may be moved inboard with respect to the C/LO if the 3-D H machine is located so far outboard that the seat edge will not permit levelling of the 3-D H machine.
- 3.6. Attach the foot and lower leg assemblies to the seat pan assembly, either individually or by using the T bar and lower leg assembly. A line through the "H" point sight buttons is parallel to the ground and perpendicular to the longitudinal centre plane of the seat.
- 3.7. Adjust the feet and leg positions of the 3-D H machine as follows:
 - 3.7.1. In the case of front outboard seats:
 - 3.7.1.1. Both feet and leg assemblies are moved forward in such a way that the feet take up natural positions on the floor, between the operating pedals if necessary. Where possible the left foot is located approximately the same distance to the left of the centre plane of the 3-D H machine as the right foot is to the right. The spirit level verifying the transverse orientation of the 3-D H machine is brought to the horizontal

by readjustment of the seat pan if necessary, or by adjusting the leg and foot assemblies towards the rear. The line passing through the H-point sight buttons is maintained perpendicular to the longitudinal centre plane of the seat.

3.7.1.2. If the left leg cannot be kept parallel to the right leg and the left foot cannot be supported by the structure, move the left foot until it is supported. The alignment of the sight buttons is maintained.

3.7.2. In the case of rear outboard seats:

For rear seats or auxiliary seats, the legs are located as specified by the manufacturer. If the feet then rest on parts of the floor which are at different levels, the foot which first comes into contact with the front seat shall serve as a reference and the other foot is so arranged that the spirit level giving the transverse orientation of the seat of the device indicates the horizontal.

3.7.3. In the case of other seats:

The general procedure indicated in paragraph 3.7.1. of this Annex is followed except that the feet are placed as specified by the vehicle manufacturer.

3.8. Apply lower leg and thigh weights and level the 3-D H machine.

3.9. Tilt the back pan forward against the forward stop and draw the 3-D H machine away from the seat back using the T bar. Reposition the 3-D H machine on the seat by one of the following methods:

3.9.1. If the 3-D H machine tends to slide rearward, use the following procedure. Allow the 3-D H machine to slide rearward until a forward horizontal restraining load on the T bar is no longer required i.e. until the seat pan contacts the seat back. If necessary, reposition the lower leg.

3.9.2. If the 3-D H machine does not tend to slide rearward, use the following procedure. Slide the 3-D H machine rearwards by applying a horizontal rearward load to the T bar until the seat pan contacts the seat back (see Figure 13-2 of Annex 13).

3.10. Apply a 100 ± 10 N load to the back and pan assembly of the 3-D H machine at the intersection of the hip angle quadrant and the T bar housing. The direction of load application is maintained along a line passing by the above intersection to a point just above the thigh bar housing (see Figure 13-2 of Annex 13). Then carefully return the back pan to the seat back. Care must be exercised throughout the remainder of the procedure to prevent the 3-D H machine from sliding forward.

3.11. Install the right and left buttock weights and then, alternately, the eight torso weights. Maintain the 3-D H machine level.

- 3.12. Tilt the back pan forward to release the tension on the seat back. Rock the 3-D H machine from side to side through 10 degrees arc (5 degrees to each side of the vertical centre plane) for three complete cycles to release any accumulated friction between the 3-D H machine and the seat.
 - 3.12.1. During the rocking action, the T bar of the 3-D H machine may tend to diverge from the specified horizontal and vertical alignment. The T bar must therefore be restrained by applying an appropriate lateral load during the rocking motions. Care is exercised in holding the T bar and rocking the 3-D H machine to ensure that no inadvertent exterior loads are applied in a vertical or fore and aft direction.
 - 3.12.2. The feet of the 3-D H machine are not to be restrained or held during this step. If the feet change position, they should be allowed to remain in that attitude for the moment.
 - 3.12.3. Carefully return the back pan to the seat back and check the two spirit levels for zero position. If any movement of the feet has occurred during the rocking operation of the 3-D H machine, they must be repositioned as follows:
 - 3.12.4. Alternately, lift each foot off the floor the minimum necessary amount until no additional foot movement is obtained. During this lifting, the feet are to be free to rotate; and no forward or lateral loads are to be applied. When each foot is placed back in the down position, the heel is to be in contact with the structure designed for this.
 - 3.12.5. Check the lateral spirit level for zero position; if necessary, apply a lateral load to the top of the back pan sufficient to level the 3-D H machine's seat pan on the seat.
- 3.13. Holding the T bar to prevent the 3-D H machine from sliding forward on the seat cushion, proceed as follows:
 - 3.13.1. Return the back pan to the seat back;
 - 3.13.2. Alternately apply and release a horizontal rearward load, not to exceed 25 N, to the back angle bar at a height approximately at the centre of the torso weights until the hip angle quadrant indicates that a stable position has been reached after load release. Care is exercised to ensure that no exterior downward or lateral loads are applied to the 3-D H machine. If another level adjustment of the 3-D H machine is necessary, rotate the back pan forward, re-level, and repeat the procedure from paragraph 3.12. of this Annex.
- 3.14. Take all measurements:
 - 3.14.1. The coordinates of the "H" point are measured with respect to the three dimensional reference system.

- 3.14.2. The actual torso angle is read at the back angle quadrant of the 3-D H machine with the probe in its fully rearward position.
- 3.15. If a rerun of the installation of the 3-D H machine is desired, the seat assembly should remain unloaded for a minimum period of 30 minutes prior to the rerun. The 3-D H machine should not be left loaded on the seat assembly longer than the time required to perform the test.
- 3.16. If the seats in the same row can be regarded as similar (bench seat, identical seats, etc.) only one "H" point and one "actual torso angle" is determined for each row of seats, the 3-D H machine described in Annex 13 being seated in a place regarded as representative for the row. This place is:
 - 3.16.1. In the case of the front row, the driver's seat;
 - 3.16.2. In the case of the rear row or rows, an outer seat.

Annex 13DESCRIPTION OF THE THREE-DIMENSIONAL H-POINT MACHINE ^{1/}
(3-D H machine)

1. BACK AND SEAT PANS

The back and seat pans are constructed of reinforced plastic and metal; they stimulate the human torso and thigh and are mechanically hinged at the "H" point. A quadrant is fastened to the probe hinged at the H-point to measure the actual torso angle. An adjustable thigh bar, attached to the seat pan, establishes the thigh centreline and serves as a baseline for the hip angle quadrant.

2. BODY AND LEG ELEMENTS

Lower leg segments are connected to the seat pan assembly at the T bar joining the knees, which is a lateral extension of the adjustable thigh bar. Quadrants are incorporated in the lower leg segments to measure knee angles. Shoe and foot assemblies are calibrated to measure the foot angle. Two spirit levels orient the device in space. Body element weights are placed at the corresponding centres of gravity to provide seat penetration equivalent to a 76 kg male. All joints of the 3-D H machine should be checked for free movement without encountering noticeable friction.

^{1/} For details of the construction of the 3-D H machine refer to Society of Automotive Engineers (SAE), 400 Commonwealth Drive, Warrendale, Pennsylvania 15096, United States of America (SAE J826 1995 version). The machine corresponds to that described in ISO Standard 6549: 1999.

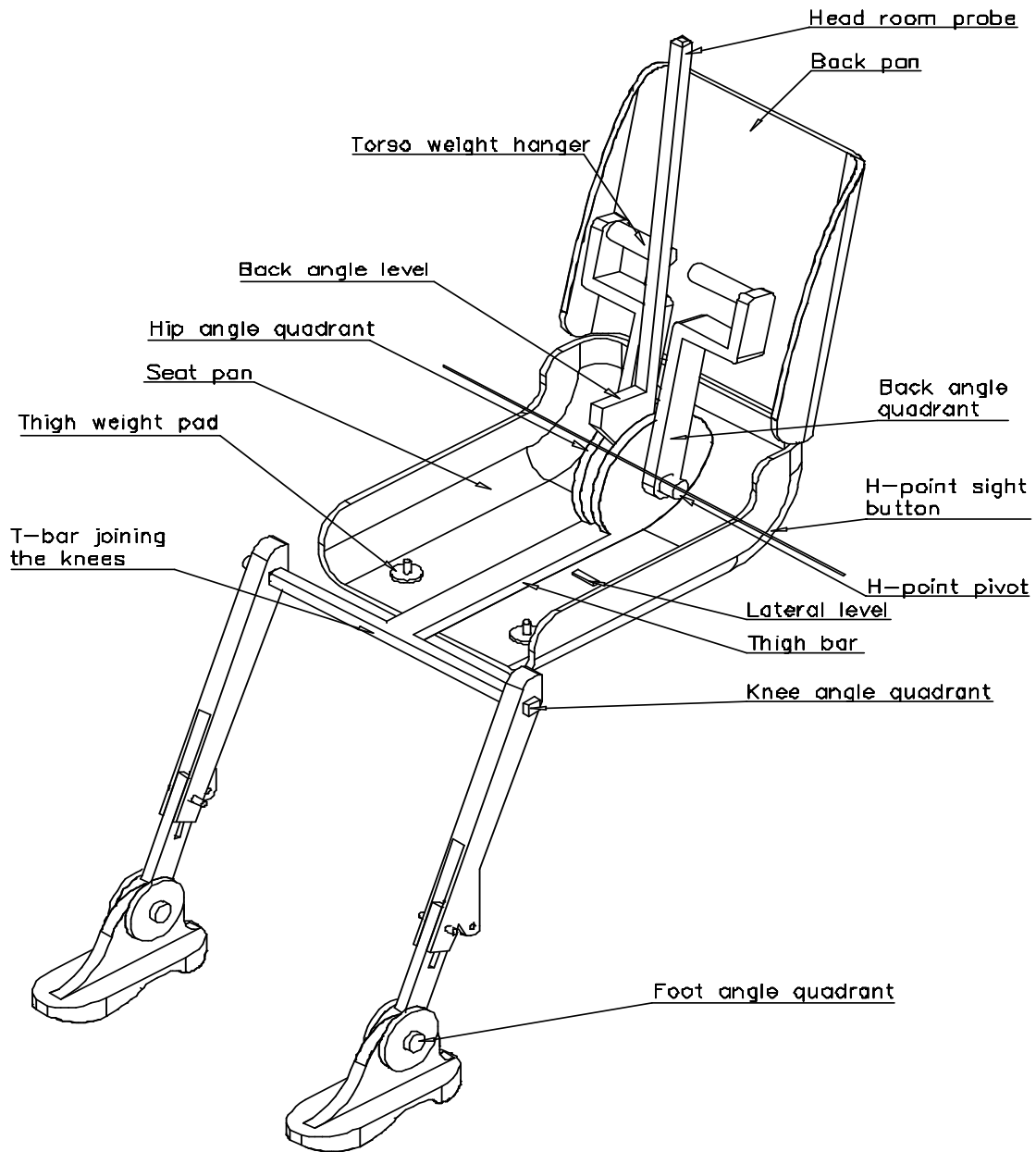

Figure 11-1 - 3-D H machine elements designation

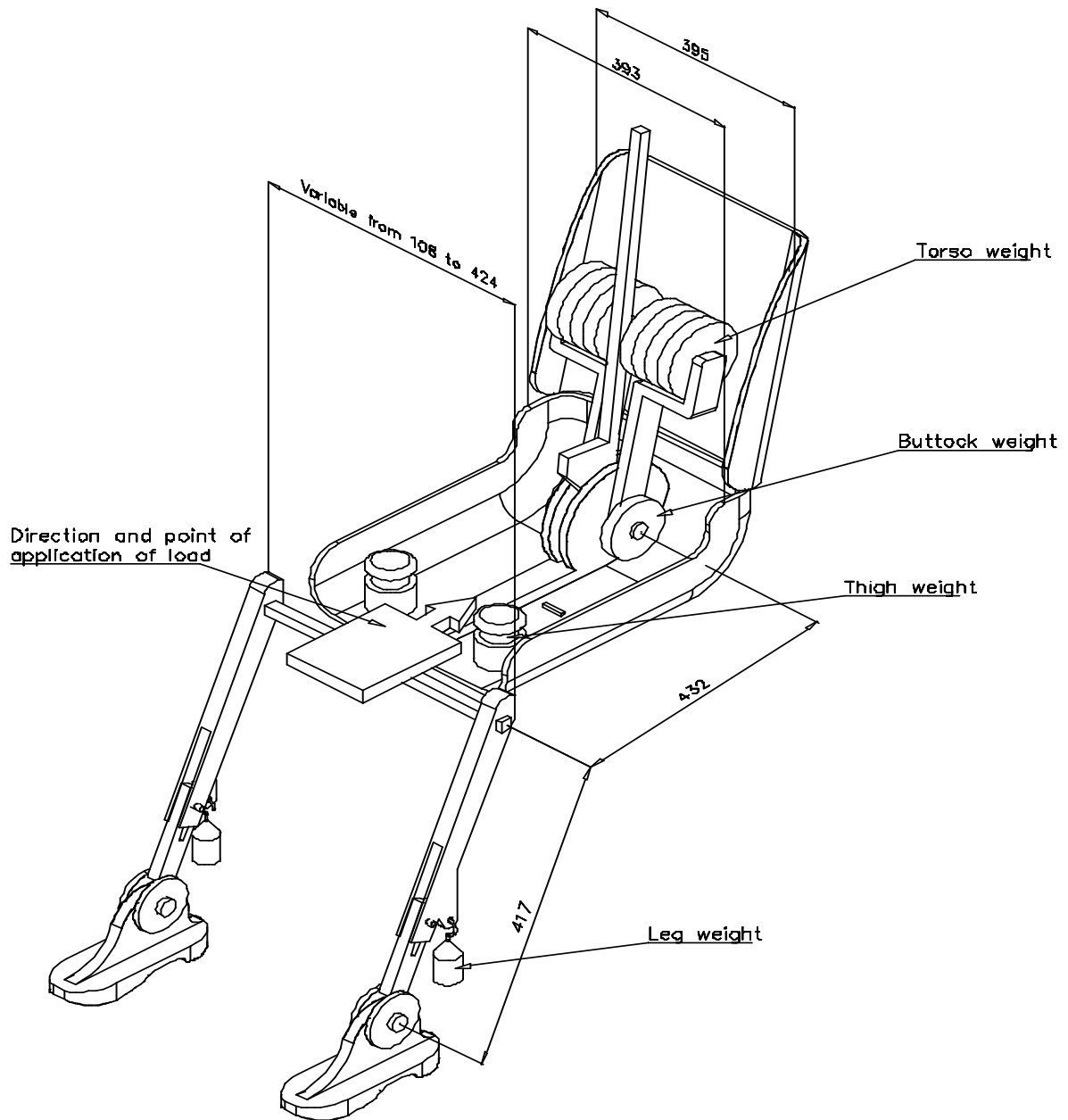

Figure 11-2 - Dimensions of the 3-D H machine elements and load distribution
(Dimensions in millimeters)
