



**Economic and Social
Council**

Distr.
GENERAL

ECE/TRANS/WP.29/2006/77
7 April 2006

Original: ENGLISH

ECONOMIC COMMISSION FOR EUROPE

INLAND TRANSPORT COMMITTEE

World Forum for Harmonization of Vehicle Regulations (WP.29)

One-hundred-and-thirty-ninth session
Geneva, 20-23 June 2006
Items 5.2.1. and B.2.2.1. of the provisional agenda

DRAFT GLOBAL TECHNICAL REGULATION ON MOTORCYCLE BRAKE SYSTEMS

Transmitted by the Chairman of the Working Party on Brakes and Running Gear (GRRF)

Note: The text reproduced below has been reviewed by GRRF at its fifty-ninth session and is submitted to WP.29 by the GRRF Chairman to aid discussion and consideration. A final text is expected to be submitted for formal consideration by WP.29 and formal vote by AC.3 at their November 2006 sessions.

This document is mainly based on ECE/TRANS/WP.29/GRRF/2006/4 and will be subject to final review at the special GRRF session scheduled to be held on 19 June 2006.

The text in square brackets has been considered but has still to be validated by the GRRF experts. Upon the request of the GRRF Chairman, some important text is marked in *italic* characters.

This document is a working document circulated for discussion and comments. The use of this document for other purposes is the entire responsibility of the user.

Documents are also available via the INTERNET:

<http://www.unece.org/trans/main/welcwp29.htm>

A. STATEMENT OF TECHNICAL RATIONALE AND JUSTIFICATION

1. INTRODUCTION

Motorcycle brake regulations have not kept pace with the advancement of modern technologies. With the improvement of disc brake systems and the recent introduction of new technologies such as anti-lock brake systems (ABS) and combined brake systems (CBS), modern motorcycles can be equipped with very sophisticated and effective braking systems. In addition, the motorcycle manufacturing and testing certification industry has become a global industry, serving a global market.

Together, the Contracting Parties to the 1998 Agreement and the motorcycle industry, have determined that work should be undertaken to address the braking performance of motorcycles as a means of improving road safety in their countries. The development of a global technical regulation (gtr) on motorcycle brake systems is intended to reduce the injuries and fatalities associated with motorcycle accidents. The Working Party on Brakes and Running Gear (GRRF) believes that it is time to update current national standards by implementing a harmonized regulation, based on the best practices within existing Contracting Party ^{1/} national regulations, while taking into account modern brake system technologies.

2. BACKGROUND

During the one-hundred-and-twenty-sixth session of the World Forum for Harmonization of Vehicle Regulations (WP.29) in March 2002, the Executive Committee AC.3 of the 1998 Global Agreement adopted the 1998 Global Agreement Programme of Work, which included the development of a gtr on motorcycle brake systems. Subsequently, Canada offered to sponsor the gtr on motorcycle braking requirements at the fifty-second session of GRRF, in September 2002. To proceed with the development of the gtr, AC.3 endorsed Canada's request to establish and chair an informal group on motorcycle brakes, at the one-hundred-and-thirtieth session of WP.29 in June 2003.

Following approval of WP.29, Canada initiated and chaired five meetings of the informal group. The meetings were open to all interested parties. Due to the time schedule and nature of the task, discussions on the content of the gtr and research necessary to develop the gtr began on 25 October 2002, prior to the establishment of the informal group. A total of seven meetings concerning the development of a gtr on motorcycle brake systems were held, including two before the informal group was established, as noted below:

- (a) 25 October 2002, in Montreal, Canada
- (b) 6 February 2003, in Geneva, Switzerland
- (c) 16-17 July 2003, in Pisa, Italy. First official meeting by the informal group concerning the gtr on motorcycle brake systems
- (d) 26-28 April 2004, in Brussels, Belgium. Second meeting by the informal group concerning the gtr on motorcycle brake systems

^{1/} As defined in ECE/TRANS/132 entitled "Agreement concerning the establishing of global technical regulations for wheeled vehicles, equipment and parts which can be fitted and/or be used on wheeled vehicles".

- (e) 08-10 November 2004, in Montreal, Canada. Third meeting by the informal group concerning the gtr on motorcycle brake systems
- (f) 27-29 June 2005, in Munich, Germany. Fourth meeting by the informal group concerning the gtr on motorcycle brake systems
- (g) 17-19 October 2005, in Brussels, Belgium. Fifth meeting by the informal group concerning the gtr on motorcycle brake systems.

The attendees for the informal group included representatives of:

- (a) Canada (Transport Canada)
- (b) United States of America (National Highway Traffic Safety Administration)
- (c) Italy
- (d) United Kingdom
- (e) Japan
- (f) India (by correspondence)
- (g) IMMA (International Motorcycle Manufacturers Association)
- (h) FEMA (Federation of European Motorcyclists' Associations)
- (i) AMA (American Motorcyclist Association)
- (j) JAMA (Japan Automobile Manufacturers Association, Inc.)

Early work on a motorcycle brake system gtr was initiated by the International Motorcycle Manufacturer's Association (IMMA). They initiated a programme of work at the forty-sixth session of GRRF in September of 2002 with the intention of completing a proposal for a gtr for motorcycle brake systems. In an effort to select the most stringent performance requirements for a gtr, the IMMA conducted an analysis of the relative stringency of three national motorcycle brake system regulations in which the UNECE Regulation No. 78, the United States Federal Motor Vehicle Safety Standard FMVSS No. 122 and the Japanese Safety Standard JSS 12-61 were compared. The subsequent reports, along with proposed provisions of a gtr, were presented at the fifty-first GRRF as informal document No. 15, and at the fifty-third GRRF session as informal document No. 26.

The United States of America, in a joint project with Canada, conducted a similar study comparing the stringency of the same three national regulations. This report was made available at the fifty-fifth session of GRRF in February of 2004. Despite using different methodologies, the results were very similar to that of the IMMA work. The results of this report were also discussed at a second informal group meeting, held in Brussels. A preliminary consensus was reached among all participants on an outline of the performance requirements of a gtr on motorcycle brake systems.

The United States and Canada conducted a further performance evaluation study, in which selected motorcycles equipped with anti-lock brake systems were compared to like models without ABS. This report was presented at the third informal group meeting in Montreal.

The studies completed by the United States and Canada and the IMMA, as well as work completed by the JAMA, provided the basis for the development of the technical requirements of the gtr.

The first formal proposal for a gtr concerning motorcycle brake systems was presented during the fifty-eighth GRRF session in September 2005, as TRANS/WP.29/GRRF/2005/18 and TRANS/WP.29/GRRF/2005/18/Add.1. A more detailed report on the technical details, deliberations and conclusions, which led to the proposed gtr, was provided separately as informal document No. GRRF-58-16.

This final report and appended gtr technical requirements are in response to Article 6 of the 1998 Agreement concerning the Establishment of Global Technical Regulations for Wheeled Vehicles, Equipment and Parts Which Can be Fitted and/or Used on Wheeled Vehicles, known as the 1998 Global Agreement. This final report has been prepared after a thoughtful review by GRRF of the proposal submitted by Canada.

3. EXISTING REGULATIONS, DIRECTIVES, AND INTERNATIONAL VOLUNTARY STANDARDS

While there were no regulations contained in the Compendium of Candidates 2/, the following regulations and standards were reviewed and used as the basis for the development of the gtr:

UNECE Regulation No. 78 - Uniform provisions concerning the approval of vehicles of category L vehicles with regard to braking.

U.S. Code of Federal Regulations (CFR) Title 49: Transportation; Part 571.122: Motorcycle brake systems.

Canada Motor Vehicle Safety Regulation No. 122 - Motorcycle brake systems.

European Union Directive 93/14/EEC, braking for category L vehicles (in effect, the same as UNECE Regulation No. 78).

Japan Safety Standard J12-61.

Australian Design Rule 33/00 - Brake systems for motorcycles and mopeds.

ISO 8710:1995, Motorcycles - Brakes and braking devices - tests and measurement methods.

ISO 12364:2001, Two-wheeled motorcycles - Antilock braking systems (ABS) - tests and measurement methods.

ISO 8709:1995, Mopeds - Brakes and braking devices - tests and measurement methods.

ISO 12366:2001, Two-wheeled mopeds - Antilock braking systems (ABS) - tests and measurement methods.

2/ As defined in ECE/TRANS/132 entitled "Agreement concerning the establishing of global technical regulations for wheeled vehicles, equipment and parts which can be fitted and/or be used on wheeled vehicles".

Most of these regulations and standards have been in existence for many years and the methods of measurement sometimes vary significantly. The technical experts were familiar with these requirements and held detailed discussions over them in their working sessions.

4. DISCUSSION OF ISSUES ADDRESSED BY THE GTR

The gtr was developed so that it would be:

- (a) applicable to all category 3 vehicles;
- (b) representative of world-wide on-road motorcycle operation;
- (c) able to provide the highest possible level of efficiency in controlling motorcycle braking;
- (d) representative of state-of-the-art testing and measurement technology, and;
- (e) applicable in practice to existing and foreseeable future braking technologies.

The informal group reviewed each of the listed regulations and standards and compared the requirements in each during the development of the gtr. These regulations and standards, in conjunction with the research and analysis, were used to develop a draft table of regulatory requirements. This draft table of requirements was continually updated as the technical issues were raised, discussed and resolved. This table was presented and discussed at the fifty-seventh GRRF session in February 2005, and discussed further at the fifty-eighth GRRF session in September 2005 in conjunction with a first draft of the proposed gtr. The informal group used the feedback from the GRRF presentations to assist with the completion of the proposed gtr, a copy of which is included in Part B of this document.

Where national regulations or standards address the same subject, e.g. dry stop or heat fade performance requirements, the informal group reviewed comparative data on the relative stringency of the requirements from the research and studies and included the most severe options. In many cases, individual members of the informal group were tasked with completing additional testing to confirm or refine the testing and performance requirements. Qualitative issues, such as which wet brake test to include, were discussed on the basis of the original rationales and the appropriateness of the tests to modern conditions and technologies.

In each of these steps, specific technical issues were raised, discussed, and resolved. The technical rationale provided in the section below describes this information.

5. TECHNICAL RATIONALE

5.1. General

The proposed gtr on motorcycle brake systems consists of a compilation of the most stringent and relevant test procedures and performance requirements from current standards and regulations. The informal group reviewed existing standards and regulations on various levels, including estimating the relative stringency of the requirements, as well as considering the original rationales for the tests and their appropriateness to modern conditions and technologies.

As a result of the comparison process, the selected performance requirements of the gtr are mainly drawn from the UNECE Regulation No. 78 (UNECE R78), the United States Federal

Motor Vehicle Safety Standard FMVSS No. 122 (FMVSS 122) and the Japanese Safety Standard JSS 12-61 (JSS 12-61).

The selected format for the gtr text is based on the alternative formats section contained in the UNECE document entitled "Format of global technical regulations (gtr)", TRANS/WP.29/883, and was chosen to facilitate quick reference and understanding of the requirements. While developing the gtr, the informal group endeavoured to clarify the selected test procedures and performance requirements to ensure a better understanding of the referenced tests and to improve consistency in the way in which the respective tests are conducted.

The gtr is comprised of several fundamental tests, each with their respective test procedures and performance requirements. These tests are listed below along with the national regulation on which they are based:

- (a) dry stop test with each service brake control operated separately (UNECE R78/JSS 12-61)
- (b) dry stop test with all service brake systems actuated simultaneously (FMVSS 122)
- (c) high speed test (JSS 12-61)
- (d) wet brake test (UNECE R78 / JSS 12-61)
- (e) heat fade test (UNECE R78 / JSS 12-61)
- (f) parking brake test (UNECE R78 / JSS 12-61)
- (g) ABS tests (UNECE R78 / JSS 12-61)
- (h) partial failure test – split service brake systems (FMVSS 122)
- (i) servo failure test.

Certain general requirements were omitted from the gtr, such as the UNECE R78 requirement that brake friction material not contain asbestos. In this instance, the national regulation does not include a referenced standardized test method with which to determine if asbestos is present, and none was proposed for that purpose. Also, the handling of asbestos and other substances known as "hazardous materials" may be addressed by those parts of the governments of the Contracting Parties that deal with public health or environmental issues. In light of the above, it was decided to omit restrictions on the content of the brake friction material, and leave this issue for resolution at the national level.

5.1.1. gtr test parameters

To maintain the integrity of a referenced test, the parameters for each test are almost entirely as specified in the respective national regulation on which the test was based. Although the national regulations share many similarities, the terminology and their respective meanings sometimes varied.

In order to streamline the text of the gtr, common terminology and definitions were based on the UNECE document entitled "Special Resolution No. 1 concerning the common definitions of vehicle categories, masses and dimensions (S.R.1)", TRANS/WP.29/1045, developed for the purposes of the gtrs. Alternate sources were referenced for more specific terms unique to this gtr, including existing national standards and publications by organizations recognized within the industry, such as the International Organization for Standardization (ISO) and the Society of Automotive Engineers (SAE).

Definitions were revised or updated when necessary, such as the terms used to describe antilock brake system (ABS), vehicle maximum speed (V_{max}) and *peak braking coefficient (PBC)*. New terminology was also introduced to bridge common definitions. For example, the terminology "lightly-loaded vehicle weight" (FMVSS 135), "unladen vehicle" (UNECE R78) and "unloaded" (JSS 12-61) essentially share the same meaning, for defining the motorcycle test mass. In an effort to streamline the gtr, the Contracting Parties agreed to use the term "lightly-loaded", as this does not conflict with existing definitions in S.R.1, nor with the definitions in other publications.

5.1.2. Measurement of deceleration and stopping distance

The UNECE R78 and JSS 12-61 test methods allow brake performance to be measured through the use of either deceleration or stopping distance, whereas FMVSS 122 evaluates performance through stopping distance only.

UNECE R78 and JSS 12-61 measure deceleration slightly differently. UNECE R78 utilizes the mean fully developed deceleration (MFDD), which is the vehicle deceleration calculated between 10 and 80 per cent of the vehicle initial speed. JSS 12-61 uses the vehicle mean saturated deceleration (MSD), which can be obtained in several ways depending on the instrumentation employed. Both methods measure a steady state deceleration rate, by excluding the transient period during the initial stage of the brake application and the very end of the braking manoeuvre. Nevertheless, the different methods can provide different results. In order to maintain consistency in the results, the MFDD was adopted to measure braking deceleration performance.

The FMVSS 122 stopping distance requirement is based on an average deceleration rate for the entire stopping manoeuvre, from the moment a force is applied to the brake control to the moment the vehicle comes to a complete stop. The UNECE R78 and JSS 12-61 stopping distance requirements are based on the MFDD (or MSD) and also include a factor for the brake system reaction time.

To maintain the integrity of the referenced test, the performance requirements are almost entirely as specified in the respective national regulation on which the test was based.

5.1.3. Vehicle test speed and corrected stopping distance

Deceleration or stopping distance performance requirements are set for a specified initial test speed. While professional test riders can approach this initial test speed, it is unlikely that the test will be started at the exact speed specified, affecting the stopping distance measurement.

A method for correcting the measured stopping distance is specified in JSS 12-61, to compensate for the difference between the specified test speed and the actual speed where the brakes were applied. Although not specified in their regulations, the National Highway Traffic Safety Administration (NHTSA) and Transport Canada also apply a correction factor to test data, using the method specified in SAE J299 – stopping distance test Procedure. The above noted stopping

distance correction methods, and the one specified in ISO 8710:1995, Motorcycles – Brakes and braking devices - tests and measurement methods, were evaluated.

SAE J299 offers the most basic method for estimating the corrected distance, and as a result the method is applicable to a speed tolerance of ± 3.2 km/h (± 2 mph). The ISO 8710 and JSS 12-61 methods are based on the same principles, but also take into consideration the brake system reaction time. These methods are applicable to a wider speed tolerance of ± 5 km/h. However, a small error in handling the system reaction time is apparent in the ISO 8710 equation, which results in higher than expected corrected values.

Based on this analysis, the informal group agreed that the stopping distance correction method specified in JSS 12-61 is the most appropriate for the gtr. Therefore, as with the existing Japanese standard, the specified test speed will include a general tolerance of ± 5 km/h, and the JSS stopping distance correction method can be used to normalize the measured test results.

5.1.4. Test surface – peak braking coefficient

Peak braking coefficient (PBC) is a measure of the coefficient of friction of the test surface and is an important parameter for assessing the brake performance of a vehicle. FMVSS 122 currently requires that the road tests be conducted on an 8-foot-wide level roadway with a skid number of 81. The road test surface conditions specified do not apply to the burnish procedure. For parking brake system tests, the test surface must be clean, dry, smooth Portland concrete cement. With the exception of the surface friction requirements for the ABS tests, the UNECE R78 and JSS 12-61 do not specify the coefficient of friction for the test surface but describe that the test surface must be level, dry, and affording good adhesion. The test lane width is also specified, as 2.5 m (8 feet).

For the non-ABS tests, UNECE R78 and JSS 12-61 rely on a subjective description of the test surface coefficient of friction. Under the self-certification system currently used by Contracting Parties such as the United States and Canada, the test surface is defined, objectively, to reduce variability of the results when testing motorcycle brake systems for compliance to their national standard. Given that the test surface coefficient of friction affects the attainable braking performance limit of a vehicle, specifying a value for the coefficient in the gtr will prevent unreasonable variability in the test results, thus providing a better and more repeatable measure of the motorcycle's actual braking ability.

The Contracting Parties agreed to define the test surface using a PBC instead of a skid number as currently specified in FMVSS 122. The PBC is a measure of tyre-to-road surface friction based on the maximum deceleration of a rolling tyre, whereas skid number is a measure of the tyre-to-road surface friction based on a skidding tyre. Therefore, a PBC is a more relevant surface friction measurement for non-locked-wheel tests, as those included in this gtr. The Contracting Parties agreed that a nominal PBC of 0.9 is an appropriate and objective value for the dry test surface used for the motorcycle brake system tests.

The United States Federal motor vehicle safety standards that currently use a PBC specify that the road test surface must have a PBC of 0.9 when measured using the American Society for Testing and Materials (ASTM) E1136 standard reference test tyre, in accordance with ASTM

Method E1337-90, at a speed of 40 mph without water delivery. However, since the ASTM test method is not widely used outside of North America and there is no common test method used in Europe or Japan, the Contracting Parties agreed to specify the PBC for the test surface, but to leave it to the national regulation to determine the test method that should be used to measure the PBC.

5.1.5. Test sequence

There is no specified test order in the UNECE R78. Similarly, JSS 12-61 indicates that tests can be done in any order, with the exception that the fade test be conducted last. FMVSS 122 requires that all tests be conducted in a specific sequence, ending with the wet brake test. The purpose here is to minimize the variability of test results through consistency in both the condition of the brakes throughout the tests and in the way in which the brakes are evaluated.

The need for a testing sequence and whether this may have any effect on braking performance was discussed. In order to eliminate the possibility of any effect, the informal group agreed to adopt a specific sequence in which the tests are conducted. The proposed sequence was selected based on increasing severity of the test on the motorcycle and its brake components, in order to preserve the condition of the brakes.

There was general agreement among the Contracting Parties that the fade test would have the greatest effect on the condition of the motorcycle brakes, which could affect brake performance in subsequent tests. For this reason, FMVSS 122 requires that a re-burnishing be conducted after the fade test, to refresh the brake components. In order to eliminate the need for re-burnishing, the informal group agreed that the fade test be the last of the motorcycle brake system performance tests, consistent with the existing practice in JSS 12-61.

The ABS test would be the next most severe test, which will result in braking at or near the limits of friction and the possibility of locked wheel braking and flat spotting the motorcycle tyres. Thus for motorcycles so equipped, the ABS test would precede the fade test. The remaining tests are not as severe on the brake system, and were sequenced according to increasing test speed for the dry stop performance tests, followed by the wet brake performance test.

The proposed test sequence is as follows:

- (a) Dry stop test - single brake control actuated;
- (b) Dry stop test - all service brake controls actuated;
- (c) High speed test;
- (d) Wet brake test;
- (e) If fitted:
 - (i) Parking brake system test;
 - (ii) ABS test;
 - (iii) Partial failure, for split service brake systems test;
 - (iv) Servo failure test.
- (f) Heat fade test.

Proposed alternatives to the testing sequence were assessed, including selecting a test sequence based on the loading of the motorcycle in order to save time, and relocating the wet brake test to second-last, before the final fade test. Either option would place the more severe brake tests earlier in the test sequence, which could affect braking performance in subsequent tests. It was therefore agreed to keep the test sequence as noted above.

5.1.6. Brake controls - force application location

Controls for the application of the brakes can include hand and foot operated control levers.

The national standards and regulations have slightly different brake control input force limits, and in the case of a hand operated control lever, there is also a discrepancy as to the location of application of the input force. One consistent element is the location and direction of application of the input force to the foot operated lever (i.e. pedal). The respective input forces are noted in the following table:

Brake actuation forces

Regulation	Foot control, F_P (N)	Hand control, F_L (N)
FMVSS 122	$25 < F_P < 400$	$10 < F_L < 245$
UNECE R78 / JSS 12-61	$F_P < 350$	$F_L < 200$

In the gtr, the specified input force remains as per the respective national regulation on which the individual test is based. In an effort to minimize confusion, the respective figures are listed for each test within the gtr.

With respect to the location of the input force on the hand-controlled lever, UNECE R78 and JSS 12-61 place the input force 50 mm from the end of the lever, while FMVSS 122 locates the input force 30 mm from the end of the handle bar grip. On most models (but not all), the control lever typically extends slightly beyond the handle bar grip, such that the control forces are almost at the same location regardless of the method followed. Depending on the regulation, however, it is not entirely clear whether this measurement should be taken along the length of the control lever or parallel to the handle bar grip; or, how to measure with a curved or angled control lever. Some interpretation is required.

The informal group agreed that none of the three national regulations is clear enough with respect to measuring the location of the input force on the hand-controlled lever. In an effort to define a common practice, a revised description for the location of the input force on the control lever and its direction of application was included in the gtr, based on ISO 8710.

5.1.7. Brake temperature measurement

Test procedures typically require the measurement of the initial brake temperature. FMVSS 122 includes a specification for plug type thermocouples, including detailed schematics addressing their installation on disc or drum type brakes. Although UNECE R78 and JSS 12-61 also require brake temperature measurement, neither makes reference to specific measurement equipment or installation methods. In informal meetings, the International Motorcycle Manufacturers

Association (IMMA) and the JAMA (Japan Automobile Manufacturers Association, Inc.) requested that rubbing thermocouples should also be considered.

The plug type thermocouples required by the NHTSA and Transport Canada are imbedded in the brake friction material, 0.04 inches (1 mm) below the contact surface, between the friction material and the disc or drum. Issues raised with this method include the effects of different friction material composition (i.e. different heat transfer rates) on temperature readings and the thermocouple installation that requires a modification of the actual brake component.

Rubbing thermocouples, also referenced as contact thermocouples, are in direct contact with the disc or drum surface, and thus do not require the dismantling or modifying of any of the brake system components. The thermocouple is spring loaded to maintain good contact with the surface whose temperature is being measured. Although this type of thermocouple can provide a quicker response to temperature change, there are limitations. Being spring loaded, the thermocouple has self-heating characteristics while rubbing against the measured surface, up to 15 °C at 50 km/h per the ISO publicly available specification, ISO/PAS 12158:2002 Road vehicles – Braking systems – Temperature measuring methods. Also, such thermocouples cannot be used or cannot be properly located on certain discs with ventilation characteristics (whether groves or cross-drilled holes).

After several discussions, including one with type approval experts from the technical service company TUV SUD Group, the informal group agreed to list both methods for measuring brake temperature. However, because of their unique characteristics, the informal group agreed that these methods would be listed in the gtr with the qualification that Contracting Parties may specify which temperature measurement method would be accepted.

With respect to the actual brake temperature values required for testing purposes, each of the national regulations on which the gtr performance requirements are based specifies a value for the initial brake temperature (IBT), prior to conducting a test. For most tests, the UNECE R78 and JSS 12-61 specify that the IBT must be less than or equal to 100 °C (212 °F), whereas FMVSS 122 specifies an IBT between 55 °C and 65 °C (130 °F and 150 °F).

The Contracting Parties agreed that a narrow IBT range could improve the repeatability of the performance tests. However, test data indicated that the narrow range required by the FMVSS 122 might not be achievable for those motorcycles equipped with a combined brake system. Therefore, the Contracting Parties agreed to specify an IBT between 55 °C and 100 °C in order to encompass all brake systems.

5.1.8. Burnishing

The burnishing procedure serves as a conditioning of the foundation brake components to permit the brake system to achieve its full capability. Burnishing typically matches the friction components to one-another and results in more stable and repeatable stops during testing. FMVSS 122 includes a burnishing procedure, whereas UNECE R78 and JSS 12-61 do not include any burnishing procedure. Under the ECE and the JSS regulations, the motorcycle is generally presented for type approval compliance testing in a burnished condition, using a procedure determined by the motorcycle manufacturer.

All United States Federal motor vehicle safety standards for brake systems (FMVSS 105, 121, 122 and 135) currently include a burnishing procedure. The burnishing procedure of FMVSS 122 requires 200 stops with both brakes applied, simultaneously, decelerating from a speed of 30 mph at 12 fps^2 with an initial brake temperature (IBT) between 55°C and 65°C (130°F and 150°F).

The Contracting Parties agreed to specify in the proposed motorcycle brake systems gtr a burnishing procedure that may be performed by the manufacturer. The procedure is based on FMVSS 122, but also includes some aspects of procedures currently used by motorcycle manufacturers in preparation for UNECE R78/JSS 12-61 type approval testing. For example, the initial speed proposed for the procedure has been changed to 50 km/h to round-off the metric equivalent, which is a slight increase from 30 mph (48 km/h) as required by FMVSS 122. An initial speed of $0.8 V_{\text{max}}$ was adopted for category 31 and 3-2 vehicles, which have a V_{max} of 50 km/h. Instead of making complete stops, the proposal also includes braking the motorcycle at the specified deceleration down to a speed between 5 km/h and 10 km/h, after which the motorcycle may be accelerated to the initial test speed for the next stop in the burnishing procedure. The primary reason for not braking the motorcycle to a complete stop is to expedite the burnishing procedure. The increased motorcycle kinetic energy resulting from the small initial speed increase of 2 km/h is likely to offset any reduction in kinetic energy resulting from not braking the motorcycle until a complete stop is reached.

The Contracting Parties agreed to propose burnishing the brakes separately since this would result in a more complete burnish for both front and rear brakes, as compared with the current FMVSS method of using both brakes simultaneously. Hence, the proposed gtr requires each brake to be burnished for 100 decelerations.

Finally, the Contracting Parties agreed to propose a change in the IBT, from the range of 55°C to 65°C currently specified in FMVSS 122, to an IBT less than or equal to 100°C . The primary reasons for proposing a change in the IBT are to accommodate the higher operational temperatures of motorcycles equipped with disc brakes and to reduce the cooling times between stops. The Contracting Parties agreed that although a narrow IBT range is important to achieve good repeatability of the performance tests, the IBT range is not as critical for the burnishing procedure.

5.2. Specific performance tests

5.2.1. Dry stop test – single brake control actuated

The purpose of a dry stop test is to ensure a minimum level of motorcycle braking performance on a dry road surface. Each of the major national motorcycle brake regulations, UNECE R78, FMVSS 122, and JSS 12-61, includes such a test in its requirements.

The UNECE R78 and the JSS 12-61 test procedures and performance requirements are similar. The UNECE R78 / JSS 12-61 regulations require that the braking performance be evaluated separately for each brake control, with the motorcycle in the laden condition and at test speeds of 40 km/h or 60 km/h depending on the vehicle category. The only exception is for vehicle

category 3-4, whereby it is specified that the brakes at all wheels must be actuated via a single foot operated control.

The main FMVSS performance requirements are quite different as they require vehicles to be tested in the lightly-loaded condition and with all brake controls applied simultaneously. The FMVSS also requires testing from 30 mph (48.3 km/h), 60 mph (96.6 km/h) and 80 mph (128.8 km/h). Consistent with being tested in the lightly-loaded condition and with both brakes applied together, the FMVSS 122 deceleration requirements are higher than in the UNECE R78/JSS 12-61. The FMVSS 122 and the UNECE R78/JSS 12-61 tests are conducted with the engine disconnected, which means that only the foundation brake performance is measured and engine braking is not a factor. Although the FMVSS 122 also requires that independent service brake systems be evaluated separately, it is conducted with the brakes in the pre-burnished condition, hence, requiring a lower level of performance.

In independent studies of the relative severity of the tests as they apply to category 3-3 motorcycles, the IMMA concluded that the UNECE R78/JSS 12-61 test was marginally more stringent, whereas the NHTSA/TC findings indicated that the FMVSS 122 test was marginally more stringent. Despite this inconsistency, neither study demonstrated a significant difference in stringency between these national regulations.

The primary advantage of the UNECE R78/JSS 12-61 requirement is that each brake control is tested separately, which ensures that each independent brake system meets specific performance criteria. In the main FMVSS 122 dry stop test with both brake controls applied simultaneously, the test rider must judge how to apportion the force applied to the front and rear brakes. This may give unrepeatable test results, or may allow the test rider to compensate for a "weak" brake. Therefore, the informal group decided to develop the dry stop test with single brake control based on UNECE R78/JSS 12-61 requirements, for the purposes of the gtr. As per present UNECE/JSS national standards, the performance requirement can be met through measurement of either the stopping distance or the MFDD.

In the event that the performance requirements cannot be achieved due to limited adhesion, the UNECE R78 includes an alternate test with the vehicle laden, using both braking devices together, for vehicle categories 3-2 and 3-3. As noted earlier, the dry stop test in UNECE R78/JSS 12-61 does not specify a value for the surface coefficient of friction, other than to say that the surface must afford good adhesion. Given that the gtr includes a requirement that the test surface must have a nominal PBC of 0.9, it was agreed that this alternative test be omitted from the gtr.

5.2.2. Dry stop test – all service brake controls actuated

The purpose of the dry stop test with all service brake controls actuated is to evaluate the full braking performance of the motorcycle from a speed of 100 km/h with both front and rear brakes applied simultaneously.

The current requirements of FMVSS 122 include a stopping distance test from 60 mph (96 km/h) with all brake controls applied simultaneously and with the motorcycle in the lightly-loaded condition. The stopping distance requirement from this speed is 185 feet (56.4 metres), which is

equivalent to an average deceleration of 6.4 m/s^2 over the entire stop. The current requirements of UNECE R78 and JSS 12-61 do not include a performance test from such a speed.

The Contracting Parties agreed to include in the proposed gtr a requirement based on the FMVSS 122 test noted above. These test parameters are relevant since they represent the typical operating conditions of a motorcycle with a single rider travelling at highway speeds. In addition, testing in the lightly loaded condition with a full brake application helps to evaluate vehicle stability during braking. Under the proposed gtr, this test would apply to vehicle categories 3-3, 3-4 and 3-5, but not to vehicle categories 3-1 and 3-2. The latter are vehicles with a maximum speed less than 50 km/h. Given this speed restriction, vehicle categories 3-1 and 3-2 will use a test speed based on 90 per cent of the maximum speed, or almost at the same exact speed as the 40 km/h test speed for the dry stop test – single brake control actuated. As the level of stringency was deemed comparable for both dry stop tests, the Contracting Parties agreed that it would be redundant to require in the proposed gtr that these vehicles undergo a dry stop test with all the service brake controls actuated.

The brake application force specified in the gtr is less than or equal to 245 N for hand levers and less than or equal to 400 N for foot pedals. Since this proposed requirement is being adopted from FMVSS 122, with a slight increase in speed to 100 km/h from 96 km/h, the Contracting Parties agreed to retain the corresponding control lever/pedal force parameters to maintain the stringency of the original test. If this dry stop requirement were adopted with the force parameters from UNECE R78 and JSS 12-61 Standards (200 N/350 N for the hand lever/foot pedal controls, respectively), it would increase the stringency of the requirement since it would effectively be proposing that the current FMVSS requirements be met with lower application forces.

The stopping distance requirement from a speed of 100 km/h is 198.5 feet (60.5 metres). In keeping with the original requirements on which this test is based, the Contracting Parties agreed to maintain the performance requirement for this dry stop test in terms of stopping distance only, thus excluding any reference to MFDD.

5.2.3. High speed test

The purpose of the high speed test is to evaluate the full braking performance of the motorcycle from a high speed and with both front and rear brakes applied simultaneously. Each of the major national motorcycle brake regulations, UNECE R78, FMVSS 122, and JSS 12-61, includes a high speed test in its requirements.

The UNECE R78 and the JSS 12-61 tests are similar and are performed from a speed of 160 km/h or 0.8 of the vehicle's maximum speed (V_{\max}), whichever is less. The UNECE R78 test requires that vehicle braking performance and behaviour be recorded, however, it does not have specific performance requirements. The performance required by JSS 12-61 includes achieving a mean fully developed deceleration (MFDD) of at least 5.8 m/s^2 or coming to a stop prior to the equivalent braking distance. The high speed effectiveness test of FMVSS 122 is conducted from a test speed that is based on the speed capability of the motorcycle, not exceeding 193.2 km/h (120 mph). When tested at the maximum speed of 120 mph, the required stopping distance is 861 feet (262.5 metres), equivalent to an average deceleration of 5.5 m/s^2 .

Based on these figures, the FMVSS 122 test appears to be more stringent due to the higher test speed, whereas the JSS 12-61 appears to be more stringent based on a deceleration requirement.

The test conditions for the FMVSS 122 and the UNECE R78/JSS 12-61 high speed tests are quite similar, including the motorcycle test mass and the simultaneous application of both brakes. The main difference between test parameters, besides the difference in the vehicle test speeds, is that the FMVSS 122 test is conducted with the engine disconnected (clutch disengaged), whereas the UNECE R78/JSS 12-61 test is conducted with the engine connected (clutch engaged). It is understood that with a connected engine, the subsequent engine braking can assist in the deceleration of the motorcycle. This effect is reduced to a minimum by placing the transmission in the highest gear during the braking manoeuvre. The benefit of having the engine connected is the effect of stabilizing the motorcycle while braking from such a high speed.

Based on the Transport Canada Test Report "Review of Motorcycle Brake Standards", the Contracting Parties believe that 100 mph (160 km/h) or 0.8 Vmax is adequate for a high speed effectiveness test since the benefits of testing from higher speeds do not warrant the potential hazard to which the rider is exposed. The Contracting Parties agree that the test speed should be limited to 160 km/h to address test facility limitations and safety concerns.

The FMVSS 122 and JSS 12-61 performance requirements are very similar from a maximum speed of 160 km/h. The equivalent average deceleration in FMVSS 122 is 5.5 m/s^2 from 100 mph, compared to the JSS 12-61 MFDD of 5.8 m/s^2 from 160 km/h. In actual testing, the performance differences for the high speed tests were too small to clearly identify one testing procedure as being more stringent than the other.

Finally, the Contracting Parties also agreed to require that the high speed test be conducted with the motorcycle engine connected and the transmission in the highest gear, per JSS 12-61, which has the effect of enhancing vehicle stability during braking from test speeds of 160 km/h.

5.2.4. Wet brake test

The purpose of the wet brake test is to ensure a minimum level of braking performance when the motorcycle is ridden in heavy rain conditions. Each of the major national motorcycle brake regulations, UNECE R78, FMVSS 122, and JSS 12-61, includes a wet brake test, but different philosophies are found in them.

The UNECE R78 and the JSS 12-61 test procedures and performance requirements are similar, but are different from the FMVSS 122 test. UNECE R78 was developed 20 years ago in the United Kingdom in order to deal with problems in the field where the braking performance of motorcycles with exposed disc brakes was significantly reduced when ridden in heavy rain. This coincided with the large scale introduction of disc brakes on motorcycles. Therefore, in order to simulate heavy rain conditions, the UNECE R78 test requires a brake performance test with a wetted brake. This is achieved by spraying water directly onto the brakes during the test.

The UNECE R78 wet brake performance evaluation begins with a baseline test where each brake is tested separately and is required to decelerate a laden motorcycle at a specified rate, using the

conditions of the dry stop test – single brake control actuated. For comparison, the same test is then repeated, but with a constant spray of water to wet the brakes. The difference in performance is evaluated immediately after the application of the respective brake, to ensure a minimum rise in deceleration performance with wet brakes. In addition, a drying brake can sometimes result in an excessively high pad friction leading to vehicle instability and wheel lock; therefore a check for this "over recovery" is also included.

As with the UNECE R78/JSS 12-61 requirement, the FMVSS 122 requires an evaluation of wet brake performance by comparison of a baseline dry stop test with performance after wetting. However, the philosophy behind the test is quite different, as the test is based on brake performance recovery following the motorcycle crossing an area of standing water. As such, the wetting procedure consists of immersing the front and rear brakes in water, separately, for two minutes each. Performance is evaluated with all brakes applied simultaneously and the wet brake recovery performance is based on the fifth stop after having immersed the brakes. The motorcycle is also tested in the lightly loaded condition. Practical problems can occur when carrying out the brake immersion requirement, due to low exhaust systems and other mechanical system locations, which may affect the motorcycle engine or transmission.

The respective brake regulations address minimum performance requirements for wet brakes, albeit under different conditions. In terms of the overall performance requirements, the stringency comparison studies by IMMA and the NHTSA/TC both concluded that the UNECE R78/JSS 12-61 performance requirements are more stringent. The Contracting Parties agreed that the UNECE R78/JSS 12-61 procedure akin to braking while riding in the rain is a more common operating condition than crossing an area covered with water.

Therefore, the Contracting Parties decided to propose a wet brake test based on the contents of the UNECE R78/JSS 12-61 test, and to make it applicable to all vehicle categories. At present, the UNECE R78/JSS 12-61 procedure excludes brakes that are fully enclosed because water is prevented from reaching the braking surface. For the purposes of the gtr, however, there was general agreement that the scope be expanded to include testing of enclosed disc brakes or drum brakes that have ventilation or inspection holes, as these include potential entry points for water spray.

5.2.5. Heat fade test

The heat fade test will ensure that a minimum level of braking performance is maintained, after numerous consecutive brake applications. In terms of real world conditions, this could be akin to frequent braking while driving in a busy suburban area or on a downhill gradient. Each of the national regulations includes a test to evaluate the brake for heat fade and any change in brake performance.

As with the wet brake test, the UNECE R78 and JSS 12-61 share the same test procedure and performance requirements. Each require that the brakes be tested separately, with the motorcycle loaded to its maximum mass capacity. The FMVSS 122 test parameters are different in that all brakes are applied simultaneously and the motorcycle test mass is set at 200 pounds (90.7 kg) above the unloaded motorcycle mass (i.e. the 200 pounds includes the mass of the test rider and test equipment).

Each test begins with a baseline test with an IBT between 55 °C and 100 °C, which provides the benchmark for performance comparison and evaluation of the heated brakes. This is followed by 10 consecutive fade stops with the purpose of building heat within the brakes. The similarities between national regulations end here. In the UNECE R78/JSS 12-61, the final performance test occurs with one stop immediately following the 10 fade stops. FMVSS 122 requires an additional five recovery stops, and the performance in the fifth stop is compared to the baseline performance. The respective regulation test parameters include additional differences such as initial test speeds, brake lever and pedal control forces, deceleration rates, and the transmission gear selection (engine connected / disconnected).

Finally, to evaluate brake fade performance, the FMVSS 122 procedure compares the brake pedal and lever actuation forces necessary to maintain the same deceleration as in the baseline test, whereas the UNECE R78/JSS 12-61 procedures compare deceleration (or stopping distance) for the same brake pedal and lever actuation forces as used in the baseline test.

Although the national regulations have distinct differences, they share the common goal of evaluating the effect of heat on braking performance. The stringency of the respective tests was evaluated separately by the IMMA and in a joint study by TC/NHTSA. The results from both studies indicated that the UNECE R78/JSS 12-61 fade test was more stringent, thus providing the basis for the requirements of the gtr.

Minor adjustments were made to the referenced national test procedure. In addition to narrowing the range for the initial brake temperature, the text was revised to use the average brake control force from the baseline test, calculated from the measured values between 80 per cent and 10 per cent of the specified vehicle test speed *The brake heating procedure was also made more objective. UNECE R78 presently requires that the motorcycle decelerate to the lesser of 3 m/s² or the maximum achievable deceleration rate with that brake control. The latter requirement is made more objective by requiring that the motorcycle meet the deceleration rate for the dry stop test – single brake control actuated, as noted in the table in paragraph 4.3.3. An alternate performance requirement is necessary given that the dry stop test – single brake control actuated performance requirement is less than 3 m/s² while braking with the rear wheel is only 2.9 m/s² or with the secondary CBS brake is only 2.5 m/s².*

The proposed gtr fade test is applicable to vehicle categories 3-3, 3-4 and 3-5, as is presently the case in the UNECE R78, JSS 12-61 and FMVSS 122. Only Canada's national regulation requires a fade test for vehicles with an engine size less than 50cc and a top speed less than 50 km/h (i.e. vehicle categories 3-1 and 3-2). However, none of the participants in the informal group could substantiate the need to include the fade test for those vehicle categories. There was no negative experience reported due to the absence of a fade test for these smaller motorcycles, and therefore it was agreed that such motorcycles would not require the heat fade test.

5.2.6. Parking brake system test

The purpose of the parking brake system requirement in the motorcycle brake systems gtr is to ensure that 3-wheeled motorcycles can remain stationary without rolling away when parked on an incline.

FMVSS 122 requires that the parking brake system be capable of holding the motorcycle stationary for 5 minutes when tested in the lightly-loaded condition on a 30 per cent grade, in the forward and reverse directions. In addition, FMVSS 122 requires that the parking brake be of a friction type with solely mechanical means to retain engagement. The parking brake requirement in UNECE R78 and JSS 12-61 are equivalent, and require that the brake must be capable of holding the motorcycle stationary on an 18 per cent grade in the laden condition (i.e., the maximum weight limit specified by the manufacturer), in the forward and reverse directions. No time limit is specified in either the ECE or JSS regulation.

The Contracting Parties agreed to use the UNECE R78/JSS 12-61 parking brake test as a basis for the proposed motorcycle brake system gtr, even though the level of stringency appears to be similar to that in FMVSS 122, given the UNECE R78's laden condition on an 18 per cent grade versus the FMVSS 122's lightly loaded condition on a 30 per cent grade. The Contracting Parties agreed that the laden condition is the worse case loading condition and test facilities around the world are more likely to have an 18 per cent grade than a 30 per cent grade available for testing.

The proposed gtr includes a requirement that the motorcycle remain stationary for 5 minutes, which was adopted from FMVSS 122. In addition, the Contracting Parties agreed that the proposed gtr retain the common requirement that the parking brake system be designed to retain engagement solely by mechanical means, but not include the FMVSS 122 requirement that the parking brake be of a friction type. This removes a design restriction and allows a manufacturer to use any parking brake system design that retains engagement by mechanical means.

5.2.7. Antilock brake system (ABS) performance

The purpose of the antilock brake system (ABS) requirements is to assess the stability and stopping performance of a motorcycle with the ABS functioning. The proposed gtr does not require that a motorcycle be equipped with ABS, but establishes minimum performance requirements for motorcycles so equipped.

UNECE R78 and JSS 12-61 include ABS specific performance requirements but do not require that ABS be fitted on motorcycles. Common to both national regulations are wheel lock tests on high-friction and low-friction surfaces and ABS failed systems performance test. In addition, the UNECE R78 performance requirements include an ABS adhesion utilization (i.e. efficiency) tests on high-friction and low-friction surfaces, a high-friction surface to low-friction surface transition stop and a low-friction surface to high-friction surface transition stop. FMVSS 122 does not include any ABS-specific performance requirements.

The Contracting Parties reviewed each of the ABS performance tests and their corresponding requirements to assess their appropriateness for the proposed motorcycle brake system gtr. With the exception of the ABS adhesion utilization test and the low-friction surface to high-friction surface transition stop, the Contracting Parties agreed to adopt, with selected revisions and clarifications, the remaining ABS test procedures and performance requirements. Possible alternatives for those tests on which a basic agreement was not achieved are discussed further below.

Of the agreed tests, in the case of the wheel lock test on a low-friction surface, the present UNECE R78 regulation states that for a road surface with a PBC = 0.35, the specified initial test speed of 80 km/h may be reduced for safety reasons, but does not specify by how much. In order to ensure consistency in the way the vehicles are evaluated and to achieve the objective of rider safety, the proposed gtr text specifies that the test speed shall be the lesser of $0.8V_{max}$ or 60 km/h for the low-friction surface test.

With regard to the low-friction to high-friction surface transition test, a clarification was included to better ensure a sudden transition between the two surfaces. In order to obtain a sufficiently low PBC, the motorcycle may initially be braked on a wetted surface, and then transition onto a dry, high friction surface. This is not a sudden transition as the motorcycle tyre is still wet and there may also be some water over the two surfaces at the transition point. In an effort to better ensure a sudden transition between test surfaces, the proposed gtr makes the further precision that the low friction surface must be followed by a wet high friction surface with a PBC exceeding 0.8.

Finally, when evaluating the performance of ABS, it is required that the ABS be cycling during the respective tests. ***The test rider must therefore apply a specific force to the brake control, which may be increased to a maximum value to ensure that the ABS is fully cycling. This maximum value will be determined in validation testing to be conducted by the informal group during the winter months of 2006.*** Depending on the ABS, some brake feedback may be felt through the brake control, such that it is not possible to maintain the specified control force. Based on test data, it was agreed that the test rider should be able to maintain the specified force within a 20 per cent margin for the entire stop.

5.2.7.1. ABS performance – stopping performance requirement

The adhesion utilization test is required by the ECE standard only, and compares the separate performance of the front and rear ABS brakes to the separate maximum braking performance of the front and rear brakes with the ABS disabled. It is evaluated on two road surfaces, a high-friction surface and a low-friction surface.

Several discussions were held on the issues of test repeatability and variability of the results. The UNECE R78 test has a high potential for producing non-repeatable results because it is a test of the maximum motorcycle braking performance as achieved by the rider of the motorcycle. Numerous factors come into play when attempting to achieve maximum performance, including rider skill, the condition of the test equipment and site (tyres, brakes and track surface), and the weather conditions. For example, the performance of ABS may be favourable when tested by a mediocre rider; however, the efficiency of ABS can diminish significantly when tested by an expert rider.

In conducting such tests, some ABS efficiency results were noted to exceed 100 per cent (i.e. improved deceleration compared to non-ABS braking performance), which is only possible when the test rider is not able to achieve the maximum available deceleration rate. In addition to rider influence, the UNECE R78 procedure is slightly flawed in that it prescribes a constant control force for the entire stop. Research has shown that the available surface friction (i.e.

PBC) increases as the vehicle speed decreases, and therefore the ABS system will have the advantage of higher deceleration rates at lower speeds. Therefore, to obtain the maximum deceleration capability without ABS, the rider would have to increase the braking control force as the motorcycle is being decelerated.

Safety and logistical issues were also noted with the UNECE R78 adhesion utilization test:

- (a) Rider safety. The test requires that the rider achieve an impending locked-wheel braking condition with the ABS disabled, to obtain maximum deceleration data with which to evaluate ABS in later tests. This impending locked-wheel braking condition is at the beginning of loss-of-control of the vehicle, which could result in a crash. Even with protective outriggers in place, it is a hazardous condition that is asked of the test rider.
- (b) Logistical. The test requires modifying the brake system to disable the ABS. This may not be a simple task, or may not be possible depending on the complexity of the motorcycle brake system. Furthermore, the standard requires that maximum deceleration be recorded with an altered brake system (i.e. with disabled ABS), hence possibly outside the manufacturer's design parameters.

In light of these issues, an alternate ABS test was developed at the fourth informal group meeting in June 2005, based on the UNECE R78. The tests developed consisted of braking on both high and low friction surfaces with ABS cycling, but with emphasis placed on maintaining vehicle stability rather than actual stopping performance. Nevertheless, stopping performance was also specified for the high friction test only, based on the minimum performance requirements of the general UNECE R78 dry stop test. No stopping distance performance requirement was specified for the low-friction surface test, as there was no baseline test in UNECE R78 with which to compare it. The proposed tests did not require the brake system to be altered, nor the rider to attempt to obtain the maximum attainable deceleration rate, thereby addressing the safety and logistical issues.

The proposed alternate test was presented at the fifty-eighth GRRF in September 2005. While there was no issue raised with regard to the test procedure, the relative stringency of the stopping performance requirements was thought to be too low compared to the existing UNECE R78 ABS requirement, which could result in unnecessarily long stopping distances when ABS is cycling.

Options were reviewed at the fifth informal meeting in October 2005, and further discussed at WP.29 in November 2005. After further consultation, a proposal was submitted by the Netherlands, which was further developed to address brake performance and vehicle stability. The result is an ABS test conducted with all service brake controls applied simultaneously, whereby brake and stability performance requirements are measured on low and high-friction surfaces. The benefits of testing all service brake controls simultaneously include being able to compare the motorcycle ABS deceleration performance to the available peak braking coefficient (PBC), without modification of the brake system and without rider influence.

Regarding stability during the brake test, the vehicle must not be affected to the extent that it requires the rider to release the brake control or that it causes a vehicle wheel to pass outside the applicable test lane.

The brake performance is based on the UNECE R78 requirement that braking with the ABS cycling must meet at least 70 per cent of the maximum braking performance without ABS. Regarding stopping performance on a high friction surface, the ABS must operate to achieve at least 70 per cent of the nominal PBC of 0.9 required for the test surface. The requirement on a low-friction surface is different in that a range of PBCs is provided from 0.3 to 0.45 and the performance requirement is based on 70 per cent of a PBC of 0.3. Unlike the high-friction surface where measurement of PBC yields consistent results, PBC values can vary on the same low friction, wetted surface. Given this characteristic, a specific range of PBC values is necessary for the low-friction ABS tests, with a performance requirement based on the low end of that surface requirement to ensure the motorcycle brake performance is not faulted by varying surface conditions.

The limit of friction values does not preclude testing at lesser values, as this would consist of more stringent conditions. However, the PBC value of 0.3 is considered to be the most slippery surface on which a rider is likely to use a motorcycle, thus the need to be included in the test range for surface friction. For motorcycles, stability on these low friction surfaces is more important than stopping performance, which is not the case for multi-track vehicle (three-wheels or more).

Braking performance at the individual wheels was also considered. Maximum braking performance at each wheel is significantly affected by the motorcycle design. For example, different braking effectiveness is available through the rear wheel of a sport motorcycle compared to that of a cruiser motorcycle. Therefore, it is not possible to set constant maximum deceleration requirements for each wheel individually, for all motorcycles types. Given this, and that individual wheel braking performance is already covered in the dry stop test – single brake control actuated, further ABS performance testing for individual wheels is not considered necessary. In the event of a motorcycle with ABS installed on only one wheel, the test rider can still apply all service brake systems simultaneously as required to meet the braking and stability requirements.

On a high-friction surface, the gtr calls for a nominal PBC of 0.9, which incorporates the real world variations found on the test track. This allows some freedom in terms of the surface friction, which does not have to be exactly 0.9 to evaluate braking performance. When testing to assure conformity to the requirements, the manufacturer would test on a surface with a lower PBC, to test for the worst-case scenario. When verification of compliance is conducted by the administrations, it is conducted on a surface with a PBC slightly above 0.9. If the vehicle is unable to meet the braking requirement on this higher friction surface, it is clear the brake system will have problems with the performance requirements, because this is the "best case" for the manufacturer.

Other scenarios considered and rejected with a PBC specified as:

- (a) "at least 0.9": would mean that the vehicle could be tested on much higher PBCs, which would lead to compliance disputes, not be representative of a real world surface and could also result in systems with a long reaction time.*
- (b) "no more than 0.9": would require the vehicle to pass on any surface with a PBC < 0.9, which would lead to compliance disputes and is unrealistic.*
- (c) "= 0.9": would not be practical as it is not possible to have a surface of exactly 0.9*

- (d) ***"from 0.8 to 0.9": would allow the authorities to test at a PBC 0.8 and manufacturers to test at a PBC 0.9, which would lead to disputes. A range in this case is unrealistic.***

Validation tests are to be conducted by the informal group during the winter months of 2006. These tests will demonstrate the effectiveness of the proposed performance requirements.

5.2.7.2. ABS performance – low-friction to high-friction surface transition stop

This is an existing test in UNECE R78, with the performance requirement that the motorcycle does not deviate from its initial course and that its deceleration must rise to an "appropriate" value. To make the test more objective and acceptable to all Contracting Parties, an actual performance number would have to be added to define what is appropriate.

At the fifth informal meeting in October 2005, Japan presented some preliminary test data that revealed a wide range of ABS performance responses to the sudden change in surface friction. Thus, at that time, it was not possible to determine a specific value that would be required to improve the objectivity of the UNECE performance requirements.

Given the ABS testing to be conducted over the winter months, the informal group has agreed to include in the test plan an evaluation of ABS system response times after crossing from a low to a high-friction surface. The purpose is to determine an actual value by which the vehicle deceleration must rise to meet the performance requirement.

5.2.8. Partial failure test – split service brake system

The split service brake system is based on the passenger car brake system and its use on motorcycles is unique to vehicles in Canada and the United States of America. The purpose of this test is to ensure that, in the event of a pressure component leakage failure in one of the hydraulic subsystems, a minimum level of braking performance is still available in the remaining hydraulic subsystem to allow the rider to bring the motorcycle to a stop.

Only the FMVSS 122 addresses a failure test for motorcycles equipped with a split service brake system. The test requirements are not applicable to vehicle categories 3-1 and 3-2. The Contracting Parties agreed that the performance requirements of FMVSS 122 are sufficient for the purposes of this gtr.

5.2.9. Power-assisted braking system failure test

An outline including all of the proposed test procedures for the gtr was presented during the fifty-seventh GRRF session, for the purposes of soliciting initial comments. One such comment concerned the absence, and requested the addition, of a power-assisted braking system failure test. None of the referenced motorcycle brake regulations or standards include such a requirement, most likely because the application of power-assisted braking systems on motorcycles is relatively new.

It is recognized that some motorcycles are presently equipped with power-assisted braking systems, and that the use of such systems could expand in the future. Existing standards are limited to motor vehicles where this technology has been in use for many years, such as on passenger cars. At present, however, there is no known performance requirement in the event of the failure of a power-assisted braking system on a motorcycle.

The informal group therefore proposes a test to ensure that, in the event of a power-assisted braking system failure, a minimum level of braking performance is still available to allow the rider to bring the motorcycle to a stop. The test is not required if the motorcycle is equipped with another separate service brake system that operates without power-assist.

In summary, the proposed test is based on the dry stop test – single brake control actuated (paragraph 4.3. of the gtr), whereby the minimum performance requirement was initially set to that required of the secondary brake system for vehicles equipped with CBS. This performance requirement was believed to be too low. For the revised proposal, in the case of separate service brake systems, each brake control must be tested separately and capable of meeting the minimum brake performance for the single rear brake system. In the case of vehicles equipped with CBS or SSBS, each brake control must be tested separately and the minimum performance requirements are those for the secondary brake system.

6. REGULATORY IMPACT AND ECONOMIC EFFECTIVENESS

Many global motorcycle brake regulations have not kept pace with the advancement of modern technologies. With the improvement of disc brake systems and the recent introduction of new technologies such as ABS and CBS, modern motorcycles can be equipped with very sophisticated and effective brake systems.

Statistics compiled to date indicate that improved motorcycle brake systems would be beneficial in reducing motorcycle accidents. Fatal motorcycle accidents have been on the rise in North America since 1997. Of particular concern is the rise in motorcycle accident fatalities for riders of the age group of 40 and above, by 8.2 per cent in Canada from 1994 to 2000, and 24.7 per cent in the United States from 1994 to 1999. In addition, statistics from the United States of America for the period of 1991 to 1999 inclusively indicate that about 13 per cent of the yearly average of 1,055 fatal single vehicle motorcycle crashes were related to braking manoeuvres. A request for additional motorcycle traffic accident data was made at the fifty-second GRRF session, to all nations, in an effort to prepare for the cost effectiveness study for the purposes of the gtr. No responses were received following this request.

The informal group reviewed the benefits of developing a gtr. The group concluded that there are many benefits to the consumer, Contracting Parties and for manufacturers. The following highlights some of the significant benefits raised during the discussions:

- (a) The gtr includes technical requirements to access recently developed technologies, such as CBS and ABS. Most regulatory requirements of the Contracting Parties do not include such current requirements.
- (b) A gtr enables motorcycle manufacturers to test their models to just one regulation/series of tests to sell globally. Currently, tests have to be carried out to

- many different regulations e.g. FMVSS No. 122 in the USA, UNECE R78 in Europe, JSS 12-61 in Japan, ADR in Australia, CMVSS No. 122 in Canada, etc.
- (c) Carrying out just one set of tests is particularly beneficial to new manufacturers and manufacturers from the emerging nations. Apart from the benefits outlined above, manufacturers' test departments need only become familiar with the gtr tests.
 - (d) It has been many years since current regulations were reviewed for their relevance. In order to compare current regulations, members of the informal gtr group (NHTSA, Transport Canada, and IMMA) carried out many vehicle tests and analyses that effectively checked the suitability of current regulations, with modifications being incorporated as required.
 - (e) The informal group gave many individuals and organizations the opportunity to come together to directly influence and participate in the development and content of the gtr. This has, in fact, been the case where a broad cross-section of motorcycle manufacturers, authorities of several countries, and the motorcycle riders' group have all participated.
 - (f) The gtr combines the better and more stringent procedures from current USA, UNECE, and Japan regulations. This will result in an enhanced gtr that will benefit all motorcycle users in terms of brake performance, brake durability, and potential safety.
 - (g) Countries that apply FMVSS/CMVSS 122 will benefit from the following:
 - (i) a wet brake test that simulates in service conditions by spraying water onto the disc;
 - (ii) a more stringent dry brake test;
 - (iii) a more stringent heat fade test;
 - (iv) a more stringent high speed test;
 - (v) an additional test to evaluate ABS performance.
 - (h) Countries that apply UNECE R78 will benefit from the following:
 - (i) a specified burnishing procedure for government conformity testing;
 - (ii) an additional test from 100 km/h with both brakes applied;
 - (iii) a more stringent high speed test;
 - (iv) additional general requirements e.g. warning lamp specification, brake system inspection;
 - (v) a specified test sequence.
 - (i) Countries that apply JSS 12-61 will benefit from the following:
 - (i) a specified burnishing procedure for government conformity testing;
 - (ii) an additional test from 100 km/h with both brakes applied;
 - (iii) additional general requirements e.g. warning lamp specification, brake system inspection;
 - (iv) a specified test sequence.

In addition, the text of the gtr will provide clear, straightforward instructions on test procedures and requirements that should be easy to follow for the tester. Additional documentation on interpretation (which is used currently) should not be necessary. This will provide a benefit to all Contracting Parties, manufacturers and testing facilities.

Motorcycles are vehicles, which are prepared for the world market. To the extent that manufacturers are preparing substantially different models in order to meet different braking

regulations, testing costs and other production values are increased. It would be more economically efficient to have manufacturers using the same test procedure and meeting the same performance requirements worldwide. This will be achieved by this gtr and thus reduce the amount of resources utilized to test motorcycles. These savings will accrue not only to the manufacturer, but also more importantly, to the consumer as well.

In summary, as the gtr has been prepared on the basis of the most stringent current requirements, there will be an increase in safety in all countries; since no one country has a monopoly on the most stringent requirement for the common test procedures. In addition, the gtr provides testing requirements applicable to new technologies such as ABS and CBS that will benefit all road users.

B. GLOBAL TECHNICAL REGULATION ON MOTORCYCLE BRAKE SYSTEMS**1. SCOPE AND PURPOSE**

This global technical regulation (gtr) specifies requirements for service brake and, where applicable, associated parking brake systems. Its purpose is to ensure safe braking performance under normal and emergency riding conditions. The gtr applies to power driven vehicles with two or three wheels *of category 3-1, 3-2, 3-3, 3-4 and 3-5, as defined in S.R.1.* */

These categories do not include:

- (a) vehicles with a Vmax of < 25 km/h
- (b) vehicles equipped for disabled drivers

2. DEFINITIONS

The following definitions apply for the purpose of interpreting this gtr */:

- 2.1. "Antilock brake system (ABS)" means a system which senses wheel slip and automatically modulates the pressure producing the braking forces at the wheel(s) to limit the degree of wheel slip.
- 2.2. "Baseline test" means a stop or a series of stops carried out in order to confirm the performance of the brake prior to subjecting it to a further test such as the Heating Procedure or wet brake stop.
- 2.3. "Brake" means those parts of the brake system where the forces opposing the movement of the vehicle are developed.
- 2.4. "Brake system" means the combination of parts consisting of the control, transmission, and brake, but excluding the engine, whose function it is to progressively reduce the speed of a moving vehicle, bring it to a halt, and keep it stationary when halted.
- 2.5. "Combined brake system (CBS)" means:
For vehicle categories 3-1 and 3-3: a service brake system where at least two brakes on different *wheels* are actuated by the operation of a single control.
For vehicle categories 3-2 and 3-4: a service brake system where the brakes on all *wheels* are actuated by the operation of a single control.
For vehicle category 3-5: a service brake system where the brakes on at least the front and rear *wheels* are actuated by the operation of a single control. (If the rear wheel and sidecar wheel are braked by the same brake system, this is regarded as the rear brake.)

*/ The definitions have, where appropriate, been taken from SPECIAL RESOLUTION No. 1 CONCERNING THE COMMON DEFINITIONS OF VEHICLE CATEGORIES, MASSES AND DIMENSIONS (S.R.1), document TRANS/WP.29/1045.

- 2.6. "Control" means the part actuated directly by the rider in order to supply or control the energy required for braking the vehicle to the transmission.
- 2.7. "Driver mass */" means the nominal mass of a driver that shall be 75 kg (subdivided into 68 kg occupant mass at the seat and 7 kg luggage mass).
- 2.8. "Engine disconnected" means when the engine is no longer connected to the driving wheel(s).
- 2.9. "Initial brake temperature" means the temperature of the hottest brake before any brake application.
- 2.10. "Laden */" means the "gross vehicle mass", which is the maximum mass of the fully laden solo vehicle based on its construction and design performances, as declared by the manufacturer. This shall be less than or equal to the sum of the maximum axles' (group of axles) capacity.
- 2.11. "Lightly loaded" means mass in running order plus 15 kg for test equipment, or the laden condition, whichever is less. In the case of ABS tests on a low friction surface (paragraphs 4.9.4. to 4.9.7.), the mass for test equipment is increased to 30 kg *to account for outriggers*.
- 2.12. "Mass in running order */" means the sum of the unladen */ vehicle mass and driver mass.
- 2.13. "Peak braking coefficient (PBC)" means the measure of tyre to road surface friction based on the maximum deceleration of a rolling tyre, measured in accordance with the method specified in national legislation.
- 2.14. "Power-assisted braking system" means a brake system in which the energy necessary to produce the braking force is supplied by the physical effort of the rider assisted by one or more energy supplying devices, for example vacuum assisted (with vacuum booster).
- 2.15. "Secondary brake system" means the second service brake system on a vehicle equipped with a combined brake system.
- 2.16. "Service brake system" means a brake system which is used for slowing the vehicle when in motion.
- 2.17. "Single brake system" means a brake system which acts on only one axle.

- 2.18. "Split service brake system (SSBS)" means a brake system *that actuates the brakes on all wheels*, consisting of two or more subsystems actuated by a single control designed so that a single failure in any subsystem (such as a leakage type failure of a hydraulic subsystem) does not impair the operation of any other subsystem.
- 2.19. "Stopping distance" means the distance travelled by the vehicle from the point of application of the control to the point at which the vehicle reaches a full stop.
- 2.20. "Test speed" means the vehicle speed measured at the moment of application of the brake control(s).
- 2.21. "Transmission" means the combination of components that provide the functional link between the control and the brake.
- 2.22. "V_{max}" means the speed attainable by accelerating at a maximum rate from a standing start for a distance of 1.6 km on a level surface, with the vehicle lightly loaded.
- 2.23. "Wheel lock" means the condition that occurs when there is a slip ratio of 1.00.

3. GENERAL REQUIREMENTS

3.1. Brake system requirements

3.1.1. Each vehicle must meet each of the tests specified for a vehicle of its category and for those brake features on the vehicle.

3.1.2. Service brake system control operation

Vehicles shall have configurations that enable a rider to operate the service brake system control whilst seated in the normal driving position and with both hands on the steering control.

3.1.3. Secondary brake system control operation:

Vehicles shall have configurations that enable a rider to operate the secondary brake system control whilst seated in the normal driving position and with at least one hand on the steering control.

3.1.4. Parking brake system:

If a parking brake system is fitted, it shall hold the vehicle stationary on the prescribed slope.

The parking brake system shall:

- (a) have a control which is separate from the service brake system controls and
- (b) be held in the locked position by solely mechanical means.

Vehicles shall have configurations that enable a rider to be able to actuate the parking brake system whilst seated in the normal driving position.

- 3.1.5. Two-wheeled vehicles of categories 31 and 33 shall be equipped with either two separate service brake systems, or a split service brake system, with at least one brake operating on the front wheel and at least one brake operating on the rear wheel.
- 3.1.6. **Three-wheeled** vehicles of vehicles category 3-5 shall comply with the brake system requirements set out in paragraph 3.1.5. above. A brake on the sidecar wheel is not required if the vehicle meets the performance requirements prescribed in section 4.
- 3.1.7. Three-wheeled vehicles of category 3-2 shall be equipped with a parking brake system plus one of the following service brake systems:
 - (a) two separate service brake systems, except CBS, which, when applied together, actuate the brakes on all wheels, or
 - (b) a split service brake system, or
 - (c) a CBS that actuates the brakes on all wheels and a secondary brake system which may be the parking brake system.
- 3.1.8. Category 3-4 vehicles shall be equipped with:
 - 3.1.8.1. a parking brake system, and
 - 3.1.8.2. a foot operated service brake system which operates on all wheels, by way of either,
 - (a) a split service brake system or;
 - (b) a CBS and a secondary brake system, which may be the parking brake system.
- 3.1.9. In cases where two separate service brake systems are installed, the systems may share a common brake, if a failure in one system does not affect the performance of the other.
- 3.1.10. For vehicles that use hydraulic fluid for brake force transmission, the master cylinder shall:
 - (a) have a **sealed, covered**, separate reservoir for each brake system;
 - (b) have a minimum reservoir capacity equivalent to 1.5 times the total fluid displacement required to satisfy the new to fully worn lining condition with the worst case brake adjustment condition; and
 - (c) have a reservoir where the fluid level is visible for checking without removal of the cover.
- 3.1.11. Vehicles that are equipped with a split service brake system shall be fitted with a red warning lamp, that is mounted in view of the rider and which shall be activated:
 - (a) when there is a hydraulic failure on the application of a force of ≈ 90 N on the control, and;

- (b) without actuation of the brake control, when the brake fluid level in the master cylinder reservoir falls below the greater of:
 - (i) the level specified by the manufacturer; and
 - (ii) the level less than or equal to half of the fluid reservoir capacity.

To permit function checking, the warning lamp shall be illuminated by the activation of the ignition switch and shall be extinguished when the check has been completed. The warning lamp shall remain on whilst a failure condition exists whenever the ignition switch is in the "on" position.

- 3.1.12. Vehicles that are equipped with an ABS system shall be fitted with a yellow warning lamp that is mounted in view of the rider. The lamp shall be activated whenever there is a malfunction that affects the generation or transmission of signals in the vehicle's ABS system.

To permit function checking, the warning lamp shall be illuminated by the activation of the ignition switch and extinguished when the check has been completed.

The warning lamp shall remain on whilst a failure condition exists whenever the ignition switch is in the "on" position.

3.2. Durability

- 3.2.1. Wear of the brakes shall be compensated for by means of a system of automatic or manual adjustment.
- 3.2.2. The friction material thickness shall either be visible without disassembly, or where the friction material is not visible, wear shall be assessed by means of a device designed for that purpose.
- 3.2.3. During all the tests in this gtr and on their completion, there shall be no friction material detachment and no leakage of brake fluid.

3.3. Measurement of dynamic performance

The method utilized to measure performance is as specified in the respective tests in paragraph 4. There are three ways in which the service brake system performance may be measured:

- 3.3.1. MFDD (Mean fully developed deceleration):

Calculation of MFDD:

$$d_m = \frac{v_b^2 - v_e^2}{25.92 \cdot (S_e - S_b)} \quad \text{m/s}^2$$

Where:

- d_m = mean fully developed deceleration
- V_1 = vehicle speed when rider actuates the control
- V_b = vehicle speed at 0.8 V_1 in km/h
- V_e = vehicle speed at 0.1 V_1 in km/h
- S_b = distance travelled between V_1 and V_b in metres
- S_e = distance travelled between V_1 and V_e in metres

3.3.2. Stopping distance:

Based on the basic equations of motion:

$$S = 0.1 \cdot V + (X) \cdot V^2$$

Where:

- S = stopping distance in metres
- V = vehicle speed in km/h
- X = a variable based on the requirement for each test

To calculate the corrected stopping distance using the actual vehicle test speed, the following formula is used:

$$S_s = 0.1 \cdot V_s + (S_a - 0.1 \cdot V_a) \cdot V_s^2 / V_a^2$$

Where:

- S_s = corrected stopping distance in metres
- V_s = specified vehicle test speed in km/h
- S_a = actual stopping distance in metres
- V_a = actual vehicle test speed in km/h

Note: This equation is only valid when the actual test speed (V_a) is within ± 5 km/h of the specified test speed (V_s)

3.3.3. Continuous deceleration recording:

For tests such as the wet brake and heat fade – heating Procedure, there is a continuous recording of the vehicle deceleration from the point where the brake control is applied until the end of the stop.

4. TEST CONDITIONS, PROCEDURES AND PERFORMANCE REQUIREMENTS

4.1. General

4.1.1. Test surfaces:

4.1.1.1. Dynamic brake tests (excluding low friction ABS tests):

The test area is a clean, dry and level surface, with a gradient = 1 per cent;
The surface has a nominal peak braking coefficient (PBC) of 0.9, unless otherwise specified.

4.1.1.2. Low friction ABS tests:

Vehicles with ABS are also tested on a clean and level surface, with a gradient = 1 per cent, with a PBC of = **0.3 and = 0.45**.

4.1.1.3. Parking brake system tests:

The specified test slope has a clean and dry surface that does not deform under the weight of the vehicle.

4.1.1.4. Test lane width:

For two-wheeled vehicles (vehicle categories 3-1 and 3-3) the test lane width is 2.5 m.

For three-wheeled vehicles (vehicle categories 3-2, 3-4 and 3-5) the test lane width is 2.5 m + the vehicle width.

4.1.2. Ambient temperature:

The ambient temperature is between 4°C and 45 °C.

4.1.3. Wind speed:

The wind speed is not more than 5 m/s

4.1.4. Test speed tolerance:

The test speed tolerance is ± 5 km/h.

In the event of the actual test speed deviating from the specified test speed, the actual stopping distance is corrected using the formula in paragraph 3.3.2.

4.1.5. Automatic transmission:

Vehicles with automatic transmission shall complete all tests - whether they are for "engine connected" or "engine disconnected".

If an automatic transmission has a neutral position, the neutral position is selected for tests where "engine disconnected" is specified.

4.1.6. Vehicle position and wheel lock:

- (a) the vehicle is positioned in the centre of the test lane for the beginning of each stop;

- (b) stops are made without the vehicle wheels passing outside the applicable test lane and without wheel lock.

4.1.7. Test sequence:

Test order	Paragraph
1. Dry stop - single brake control actuated	4.3.
2. Dry stop - all service brake controls actuated	4.4.
3. High speed	4.5.
4. Wet brake	4.6.
5. Heat fade <u>1</u> /	4.7.
6. If fitted:	
6.1. Parking brake system	4.8.
6.2. ABS	4.9.
6.3. Partial failure, for split service brake systems	4.10.
6.4. Power-assisted braking system failure	4.11.

Note 1/: Heat fade is always the last test to be carried out.

4.2. Preparation

4.2.1. Engine idle speed:

The engine idle speed is set to the manufacturer's specification.

4.2.2. Tyre pressures:

The tyres are inflated to the manufacturer's specification for the vehicle loading condition for the test.

4.2.3. Control application points and direction:

For a hand control lever, the input force (F) is applied on the control lever's forward surface perpendicular to the axis of the lever fulcrum and its outermost point on the plane along which the control lever rotates (see figure below).

The input force is applied to a point located 50 mm from the outermost point of the control lever, measured along the axis between the central axis of the fulcrum of the lever and its outermost point.

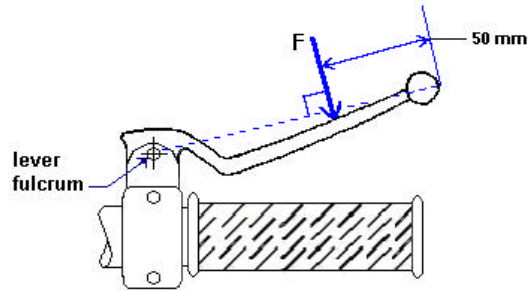

For a foot control pedal, the input force is applied to the centre of, and at right angles to, the control pedal.

4.2.4. Brake temperature measurement:

Based on a determination by each Contracting Party or regional economic integration organization, the brake temperature is measured on the approximate centre of the braking path of the disc or drum using:

- (a) a rubbing thermocouple that is in contact with the surface of the disc or drum or;
- (b) a thermocouple that is embedded in the friction material.

4.2.5. Burnishing procedure:

The vehicle brakes must be burnished prior to evaluating performance. This procedure may be completed by the manufacturer.

- (a) Vehicle lightly loaded.
- (b) Engine disconnected.
- (c) Test speed:
 - (i) Initial speed: = 50 km/h for vehicle categories 3-3, 3-4 and 3-5
= 0.8 V_{max} for vehicle categories 3-1 and 3-2
 - (ii) Final speed = 5 to 10 km/h.
- (d) Brake application:
 - (i) Each **service brake system** control applied separately.
- (e) Vehicle deceleration:
 - (i) Single front brake system only:
3.0-3.5 m/s^2 for vehicle categories 3-3, 3-4 and 3-5
1.5-2.0 m/s^2 for vehicle categories 3-1 and 3-2
 - (ii) Single rear brake system only: 1.5-2.0 m/s^2
 - (iii) CBS or split service brake system: 3.5-4.0 m/s^2
- (f) Number of decelerations: 100 per brake system.
- (g) Initial brake temperature before each brake application = 100 °C.
- (h) For the first stop, accelerate the vehicle to the initial speed and then actuate the brake control under the conditions specified until the final speed is reached. Then reaccelerate to the initial speed and maintain that speed until the brake temperature falls to the specified initial value. When these conditions are met,

reapply the brake control as specified. Repeat this procedure for the number of specified decelerations.

4.3. Dry stop test – single brake control actuated

4.3.1. Vehicle condition:

- (a) The test is applicable to all vehicle categories.
- (b) Laden
For vehicles fitted with CBS and split service brake systems: the vehicle is tested in the lightly loaded condition in addition to the laden condition.
- (c) Engine disconnected

4.3.2. Test conditions and procedure:

- (a) Initial brake temperature: = 55 °C and = 100 °C
- (b) Test speed:
 - (i) Vehicle categories 3-1 and 3-2: 40 km/h or 0.9 V_{max}, whichever is the lower
 - (ii) Vehicle categories 3-3, 3-4 and 3-5: 60 km/h or 0.9 V_{max}, whichever is the lower
- (c) Brake application:
Each *service brake system* control applied separately.
- (d) Brake actuation force:
 - (i) Hand control: = 200 N
 - (ii) Foot control: = 350 N for vehicle categories 3-1, 3-2, 3-3 and 3-5
= 500 N for vehicle category 3-4
- (e) Number of stops:
until the vehicle meets the performance requirements, with a maximum of 6 stops
- (f) For each stop, accelerate the vehicle to the test speed and then actuate the brake control under the conditions specified in this paragraph.

4.3.3. Performance requirements:

When the brakes are tested in accordance with the test procedure set out in paragraph 4.3.2., the stopping distance shall be as specified in column 2 or the MFDD shall be as specified in column 3 of the following table:

Column 1 Vehicle Category	Column 2 STOPPING DISTANCE (S) (Where V is the specified test speed in km/h and S is the required stopping distance in metres)	Column 3 MFDD
Single brake system, front wheel(s) braking only:		
3-1	$S = 0.1 V + 0.0111 V^2$	= 3.4 m/s ²
3-2	$S = 0.1 V + 0.0143 V^2$	= 2.7 m/s ²
3-3	$S = 0.1 V + 0.0087 V^2$	= 4.4 m/s ²
3-4	Not applicable	Not applicable
3-5	$S = 0.1 V + 0.0105 V^2$	= 3.6 m/s ²
Single brake system, rear wheel(s) braking only:		
3-1	$S = 0.1 V + 0.0143 V^2$	= 2.7 m/s ²
3-2	$S = 0.1 V + 0.0143 V^2$	= 2.7 m/s ²
3-3	$S = 0.1 V + 0.0133 V^2$	= 2.9 m/s ²
3-4	Not applicable	Not applicable
3-5	$S = 0.1 V + 0.0105 V^2$	= 3.6 m/s ²
Vehicles with CBS or split service brake systems: for laden and lightly loaded conditions.		
3-1 and 3-2	$S = 0.1 V + 0.0087 V^2$	= 4.4 m/s ²
3-3	$S = 0.1 V + 0.0076 V^2$	= 5.1 m/s ²
3-4	$S = 0.1 V + 0.0077 V^2$	= 5.0 m/s ²
3-5	$S = 0.1 V + 0.0071 V^2$	= 5.4 m/s ²
Vehicles with CBS – secondary service brake systems:		
ALL	$S = 0.1 V + 0.0154 V^2$	= 2.5 m/s ²

4.4. Dry stop test – all service brake controls actuated

4.4.1. Vehicle condition:

- (a) The test is applicable to vehicle categories 3-3, 3-4 and 3-5.
- (b) Lightly loaded.
- (c) Engine disconnected

4.4.2. Test conditions and procedure

- (a) Initial brake temperature: = 55 °C and = 100 °C.
- (b) Test speed: 100 km/h or 0.9 V_{max}, whichever is the lower.
- (c) Brake application:
Simultaneous application of both *service brake system* controls, if so equipped, or of the single service brake control in the case of a service brake system that operates on all wheels.
- (d) Brake actuation force:
Hand control: = 250 N
Foot control: = 400 N for vehicle categories 3-3 and 3-5
= 500 N for vehicle category 3-4
- (e) Number of stops: until the vehicle meets the performance requirements, with a maximum of 6 stops.
- (f) For each stop, accelerate the vehicle to the test speed and then apply the brake controls under the conditions specified in this paragraph.

4.4.3. Performance requirements:

When the brakes are tested in accordance with the test procedure set out in paragraph 4.4.2., the stopping distance (S) shall be:

(a) For test speeds < 80.5 km/h, $S = 0.0055 V^2$

(b) For test speeds = 80.5 km/h, $S = 0.0060 V^2$

(where V is the specified test speed in km/h and S is the required stopping distance in metres)

4.5. High speed test

4.5.1. Vehicle condition:

(a) The test is applicable to vehicle categories 3-3, 3-4 and 3-5.

(b) Test is not required for vehicles with $V_{max} = 125$ km/h.

(c) Lightly loaded.

(d) Engine connected with the transmission in the highest gear.

4.5.2. Test conditions and procedure:

(a) Initial brake temperature: = 55 °C and = 100 °C.

(b) Test speed: 0.8 V_{max} for vehicles with $V_{max} > 125$ km/h and < 200 km/h;
160 km/h for vehicles with $V_{max} = 200$ km/h.

(c) Brake application:

Simultaneous application of both *service brake system* controls, if so equipped, or of the single *service brake system* control in the case of a service brake system that operates on all wheels.

(d) Brake actuation force:

Hand control = 200 N

Foot control = 350 N for vehicle categories 3-3, and 3-5

= 500 N for vehicle category 3-4

(e) Number of stops: until the vehicle meets the performance requirements, with a maximum of 6 stops.

(f) For each stop, accelerate the vehicle to the test speed and then apply the brake control(s) under the conditions specified in this paragraph.

4.5.3. Performance requirements:

When the brakes are tested in accordance with the test procedure set out in paragraph 4.5.2.:

(a) The stopping distance (S) shall be = $0.1 V + 0.0067 V^2$

(where V is the specified test speed in km/h and S is the required stopping distance in metres) or the MFDD shall be = 5.8 m/s^2 .

4.6. Wet brake test

4.6.1. General information:

- (a) The test comprises two parts that are carried out consecutively for each brake system:
 - (i) A baseline test based on the dry stop test - single brake control actuated (paragraph 4.4.3.).
 - (ii) A single wet brake stop using the same test parameters as in (i) above but with the brake(s) being continuously sprayed with water while the test is conducted in order to measure the brakes' performance in wet conditions.
- (b) ***The test is not applicable to parking brake systems, unless it is the secondary brake.***
- (c) Drum brakes or fully enclosed disc brakes are exempt from this test unless ventilation or open inspection ports are present.
- (d) This test requires the vehicle to be fitted with instrumentation that gives a continuous recording of brake control force and vehicle deceleration. The MFDD and the stopping distance measurements are not appropriate in this case.

4.6.2. Vehicle condition:

- (a) The test is applicable to all vehicle categories
- (b) Laden
For vehicles fitted with CBS and split service brake systems: the vehicle is tested in the lightly loaded condition in addition to the laden condition.
- (c) Engine disconnected

- (d) Each brake is fitted with water spray equipment
(i) Disc brakes: Sketch of water spray equipment:

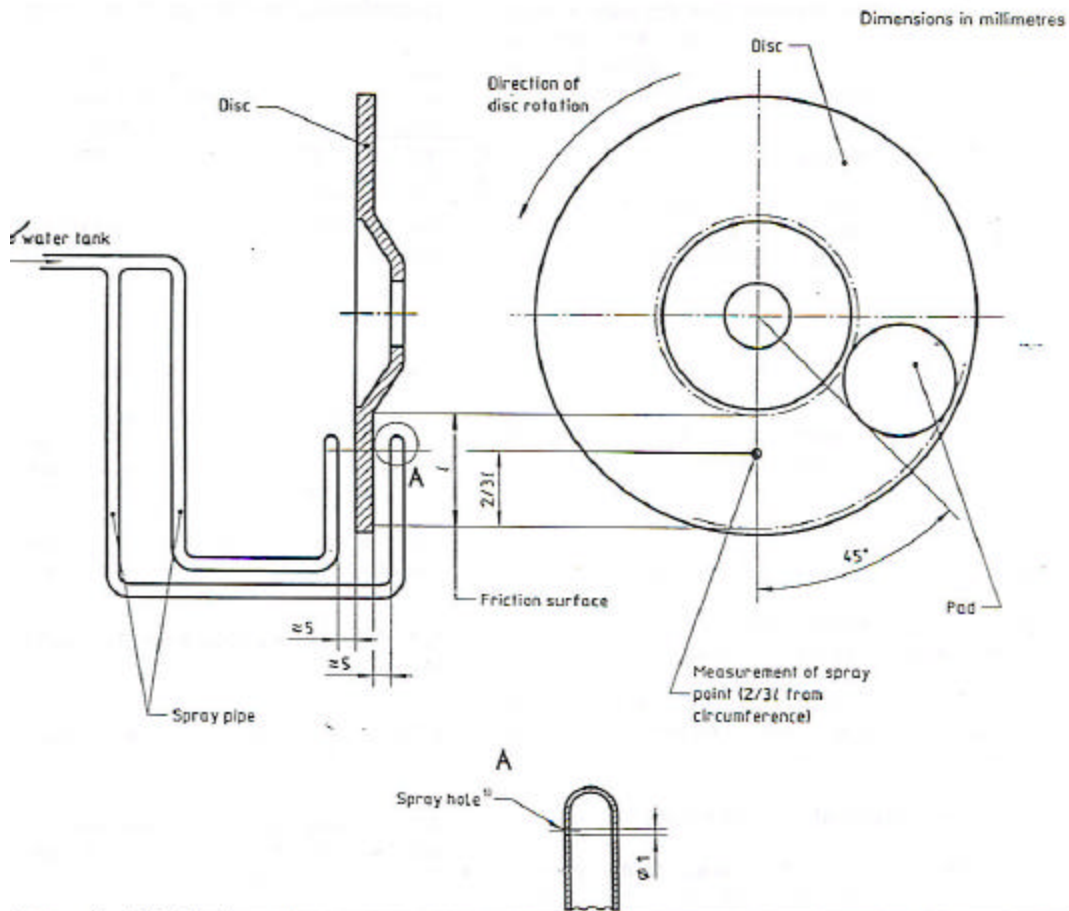

Spray water shall not be dispersed.

The disc brake water spray equipment shall be installed as follows:

- Water shall be sprayed onto each brake with a flow rate of 15 litres/hr. The water shall be equally distributed on each side of the rotor.
 - If the surface of the rotor has any shielding, the spray shall be applied 45° prior to the shield.
 - If it is not possible to locate the spray in the position shown on the sketch, or if the spray coincides with a brake ventilation hole or similar, the spray nozzle may be advanced by an additional 90° maximum from the edge of the pad, using the same radius.
- (ii) Drum brakes with ventilation and open inspection ports:
The water spray equipment is installed as follows:
- Water is sprayed equally onto both sides of the drum brake assembly (on the stationary back plate and on the rotating drum) with a flow rate of 15 litres/hr.

- b. The spray nozzles are positioned two thirds of the distance from the outer circumference of the rotating drum to the wheel hub centre.
- c. The nozzle position is $> 15^\circ$ from the edge of any opening in the drum back plate.

4.6.3. Baseline test:

4.6.3.1. Test conditions and procedure

- (a) The test in paragraph 4.3. (dry stop test - single brake control actuated) is carried out for each brake system but with the brake control force that results in a vehicle deceleration of $2.5 - 3.0 \text{ m/s}^2$, and the following is determined:
 - (i) The average brake control force measured when the vehicle is travelling between 80 per cent and 10 per cent of the specified test speed.
 - (ii) The average vehicle deceleration in the period 0.5 to 1.0 seconds after the point of application of the brake control.
 - (iii) The maximum vehicle deceleration during the complete stop but excluding the final 0.5 seconds.
- (b) Conduct 3 baseline stops and average the values obtained in (i), (ii), and (iii) above.

4.6.4. Wet brake stop:

4.6.4.1. Test conditions and procedure

- (a) The vehicle is ridden at the test speed used in the baseline test set out in paragraph 4.6.3. with the water spray equipment operating on the brake(s) to be tested and with no actuation of the brake system.
- (b) After a distance of $\approx 500 \text{ m}$, apply the average brake control force determined in the baseline test for the brake system being tested.
- (c) Measure the average vehicle deceleration in the period 0.5 to 1.0 seconds after the point of application of the brake control.
- (d) Measure the maximum vehicle deceleration during the complete stop but excluding the final 0.5 seconds.

4.6.5. Performance requirements:

When the brakes are tested in accordance with the test procedure set out in paragraph 4.6.4.1., the wet brake deceleration performance shall be:

The value measured in paragraph 4.6.4.1(c) = 60 per cent of the average deceleration values recorded in the baseline test in paragraph 4.6.3.1.(ii), i.e. in the period 0.5 to 1.0 seconds after the point of application of the brake control.

The value measured in 4.6.4.1(d) = 120 per cent of the average deceleration values recorded in the baseline test 4.6.3.1.(iii), i.e. during the complete stop but excluding the final 0.5 seconds.

4.7. Heat fade test

4.7.1. General information:

- (a) The test comprises three parts that shall be carried out consecutively for each brake system:
 - (i) A baseline test using the dry stop test - single brake control actuated (paragraph 4.3.).
 - (ii) A heating procedure which consists of a series of repeated stops in order to heat the brake(s).
 - (iii) A hot brake stop using the dry stop test - single brake control actuated (paragraph 4.3.), to measure the brake's performance after the heating procedure.
- (b) The test is applicable to vehicle categories 3-3, 3-4 and 3-5.
- (c) The test is not applicable to parking brake systems and secondary service brake systems.
- (d) All stops are carried out with the vehicle laden.
- (e) The heating procedure requires the vehicle to be fitted with instrumentation that gives a continuous recording of brake control force and vehicle deceleration. The MFDD and stopping distance measurements are not appropriate for the heating procedure. The baseline test and the hot brake stop require the measurement of either MFDD or the stopping distance.

4.7.2. Baseline test:

4.7.2.1. Vehicle condition.

- (a) Engine disconnected

4.7.2.2. Test conditions and procedure

- (a) Initial brake temperature: = 55 °C and = 100 °C.
- (b) Test speed: 60 km/h or 0.9 V_{max}, whichever is the lower.
- (c) Brake application:
Each *service brake system* control applied separately
- (d) Brake actuation force:
 - Hand control = 200 N
 - Foot control = 350 N for vehicle categories 3-3 and 3-5
 - = 500 N for vehicle category 3-4
- (e) Accelerate the vehicle to the test speed, actuate the brake control under the conditions specified and record the control force required to achieve the vehicle braking performance specified in the table to paragraph 4.3.3.

4.7.3. Heating Procedure:

4.7.3.1. Vehicle condition

- (a) Engine transmission:
 - (i) From the specified test speed to 50 per cent specified test speed: connected, with the highest appropriate gear selected such that the engine speed remains above the manufacturer's specified idle speed.

- (ii) From 50 per cent specified test speed to standstill: disconnected.

4.7.3.2. Test conditions and procedure

- (a) Initial brake temperature prior to first stop only: = 55 °C and = 100 °C.
- (b) Test speed:
 - Single brake system, front wheel braking only:
100 km/h or 0.7 V_{max}, whichever is the lower.
 - Single brake system, rear wheel braking only:
80 km/h or 0.7 V_{max}, whichever is the lower.
 - CBS or split service brake system:
100 km/h or 0.7 V_{max}, whichever is the lower.
- (c) Brake application:
Each **service brake system** control applied separately
- (d) Brake actuation force:
 - (i) For the first stop:
The constant control force that achieves a vehicle deceleration rate of 3.0 - 3.5 m/s² while the vehicle is decelerating between 80 per cent and 10 per cent of the specified speed.
If the vehicle is unable to achieve the specified vehicle deceleration rate, these stops are carried out to meet the deceleration requirements in the table in paragraph 4.3.3.
 - (ii) For the remaining stops:
 - a. The same constant brake control force as used for the first stop.
 - b. Number of stops: 10.
 - c. Interval between n stops: 1000 m.
- (e) Carry out a stop to the conditions specified in this paragraph and then immediately use maximum acceleration to reach the specified speed and maintain that speed until the next stop is made.

4.7.4. Hot brake stop:

4.7.4.1. Test conditions and procedure

Perform a single stop under the conditions used in the baseline test (paragraph 4.7.2.) for the brake system that has been heated during the procedure in accordance with paragraph 4.7.3. This stop is carried out within one minute of the completion of the procedure set out in paragraph 4.7.3. with a brake actuation force less than or equal to the force used during the test set out in paragraph 4.7.2.

4.7.5. Performance Requirements:

When the brakes are tested in accordance with the test procedure set out in paragraph 4.7.4.1.:

- (a) The stopping distance: $S_2 = 1.67 S_1 - 0.67 \times 0.1V$

Where:

S_1 = corrected stopping distance in metres achieved in the baseline test set out in paragraph 4.7.2.

S_2 = corrected stopping distance in metres achieved in the hot brake stop set out in paragraph 4.7.4.1. above.

V = specified test speed in km/h.

or

- (b) The MFDD = 60 per cent of the MFDD recorded in the test set out in paragraph 4.7.2. above.

4.8. Parking brake system test – for vehicles equipped with parking brakes

4.8.1. Vehicle condition:

- (a) The test is applicable to vehicle categories 3-2, 3-4 and 3-5.
- (b) Laden
- (c) Engine disconnected

4.8.2. Test conditions and procedure:

- (a) Initial brake temperature: = 100 °C.
- (b) Test surface gradient = 18 per cent.
- (c) Brake actuation force:
Hand control = 400 N.
Foot control = 500 N.
- (d) For the first part of the test, park the vehicle on the test surface gradient facing up the slope by actuating the brake system under the conditions specified in this paragraph. If the vehicle remains stationary, start the measurement of the test period.
- (e) On completion of the test with vehicle facing up the gradient, repeat the same test procedure with the vehicle facing down the gradient.

4.8.3. Performance requirements:

When tested in accordance with the test procedure set out in paragraph 4.8.2., the parking brake system shall hold the vehicle stationary for 5 minutes when the vehicle is both facing up and facing down the gradient.

4.9. ABS tests

4.9.1. General information:

- (a) The tests are only applicable to the ABS fitted on vehicle categories 3-1 and 3-3.
- (b) The tests are to confirm the performance of brake systems equipped with ABS and their performance in the event of ABS electrical failure.
- (c) In practice, wheel lock is judged to have occurred when a vehicle's speed exceeds 15 km/h while its wheel speed falls below 5 km/h at the tyre to road interface.
- (d) "Fully cycling" means that the anti-lock system is repeatedly modulating the brake force to prevent the directly controlled wheels from locking. Brake applications where modulation only occurs once during the stop shall not be considered to meet this definition.

- (e) ***Wheel-lock shall be allowed provided that the stability of the vehicle is not affected to the extent that it requires the operator to release the control or that it causes a vehicle wheel to pass outside the applicable test lane.***

The test series comprises the following individual tests, which may be carried out in any order:

ABS TESTS	PARAGRAPH
a. Stops on a high friction surface - as specified in paragraph 4.1.1.1.	4.9.3.
b. Stops on a low friction surface - as specified in paragraph 4.1.1.2.	4.9.4.
c. Wheel lock checks on high and low friction surfaces.	4.9.5.
d. Wheel lock check - high to low friction surface transition.	4.9.6.
e. Wheel lock check - low to high friction surface transition.	4.9.7.
f. Stops with an ABS electrical failure.	4.9.8.

- 4.9.2. Vehicle condition:
 (a) Lightly loaded.
 (b) Engine disconnected

- 4.9.3. Stops on a high friction surface:

- 4.9.3.1. Test conditions and procedure

- (a) Initial brake temperature: = 55 °C and = 100 °C.
 (b) Test speed: 60 km/h or 0.9 Vmax, whichever is lower.
 (c) Brake application:
Simultaneous application of both service brake system controls, if so equipped, or of the single service brake control in the case of a service brake system that operates on all wheels.
 (d) Brake actuation force:
 [Hand control = 200 N ± 20 per cent;
 Foot control = 350 N ± 20 per cent.
 These forces may be increased in order to ensure that the ABS is fully cycling during the stop.
Note: The higher forces are needed to ensure that the performance of the ABS in the certification test is actually measured. To work out the appropriate figures for the maximum force value, future test work should progressively increase the force applied, until the ABS cycles fully. From these figures on different motorcycles a final value can be agreed.
 For systems where the brake actuation force fluctuates due to ABS operation, the nominal brake actuation force is the mean value applied for the duration of the stop.
 (e) ***If one wheel is not equipped with ABS, the control for the service brake on that wheel shall be applied with a force that is lower than the force that will cause the wheel to lock.***
 (f) Number of stops: until the vehicle meets the performance requirements, with a maximum of 6 stops.

- (g) For each stop, accelerate the vehicle to the test speed and then actuate the brake control under the conditions specified in this paragraph.

4.9.3.2. Performance requirements

When the brakes are tested in accordance with the test procedures referred to in paragraph 4.9.3.1.,

[(a) *the stopping distance (S) shall be = 0.0063V² (where V is the specified test speed in km/h and S is the required stopping distance in meters) or the MFDD shall be 6.17 m/s²,*]

- (b) there shall be no wheel lock and the vehicle wheels shall stay within the test lane.

4.9.4. Stops on a low friction surface

4.9.4.1. Test conditions and procedure:

As set out in paragraph 4.9.3.1. but using the low friction surface instead of the high friction one.

4.9.4.2. Performance requirements

When the brakes are tested in accordance with the test procedures set out in paragraph 4.9.4.1.,

[(a) *the stopping distance (S) shall be = 0.0188V² (where V is the specified test speed in km/h and S is the required stopping distance in meters) or the MFDD shall be 2.05 m/s²,*]

- (b) there shall be no wheel lock and the vehicle wheels shall stay within the test lane.

4.9.5. Wheel lock checks on high and low friction surfaces:

4.9.5.1. Test conditions and procedure

(a) Test surfaces:

- (i) High friction and
- (ii) Low friction.

(b) Initial brake temperature: = 55 °C and = 100 °C.

(c) Test speed:

- (i) On high friction surface: 80 km/h or 0.8 V_{max}, whichever is lower.
- (ii) On low friction surface: 60 km/h or 0.8 V_{max}, whichever is lower.

(d) Brake application:

- (i) Each *service brake system* control applied separately:
- (ii) Where ABS is fitted to both brake systems, simultaneous application of both brake controls in addition to (i).

(e) Brake actuation force:

Hand control = 200 N ± 20 per cent;

Foot control = 350 N ± 20 per cent.

These forces may be increased in order to ensure that the ABS is fully cycling during the stop.

For systems where the brake actuation force fluctuates due to ABS operation, the nominal brake actuation force is the mean value applied for the duration of the stop.

- (f) Brake application rate:
The brake actuation force shall be applied in 0.2 – 0.5 seconds.
- (g) Number of stops: until the vehicle meets the performance requirements, with a maximum of 3 stops.
- (h) For each stop, accelerate the vehicle to the test speed and then actuate the brake control under the conditions specified in this paragraph.

4.9.5.2. Performance requirements:

When the brakes are tested in accordance with the test procedures set out in paragraph 4.9.5.1., there shall be no wheel lock and the vehicle wheels shall stay within the test lane.

4.9.6. Wheel lock check - high to low friction surface transition

4.9.6.1. Test conditions and procedure

- (a) Test surfaces:
A high friction surface immediately followed by a low friction surface.
- (b) Initial brake temperature: = 55 °C and = 100 °C.
- (c) Test speed:
The speed that will result in 50 km/h or 0.5 V_{max}, whichever is the lower, at the point where the vehicle passes from the high friction to the low friction surface.
- (d) Brake application:
 - (i) Each *service brake system* control applied separately:
 - (ii) Where ABS is fitted to both brake systems, simultaneous application of both brake controls in addition to (i) above.
- (e) Brake actuation force:
Hand control = 200 N ± 20 per cent.
Foot control = 350 N ± 20 per cent.
These forces may be increased in order to ensure that the ABS is fully cycling during the stop.
For systems where the brake actuation force fluctuates due to ABS operation, the nominal brake actuation force is the mean value applied for the duration of the stop.
- (f) Number of stops: until the vehicle meets the performance requirements, with a maximum of 3 stops.
- (g) For each stop, accelerate the vehicle to the test speed and then actuate the brake control before the vehicle reaches the transition from one friction surface to the other.

- 4.9.6.2. Performance requirements
When the brakes are tested in accordance with the test procedures set out in paragraph 4.9.6.1., there shall be no wheel lock and the vehicle wheels shall stay within the test lane.
- 4.9.7. Wheel lock check - low to high friction surface transition
- 4.9.7.1. Test conditions and procedure
- (a) Test surfaces:
A wet low friction surface immediately followed by a wet high friction surface of $> 0.8\text{PBC}$.
 - (b) Initial brake temperature: = 55 °C and = 100 °C.
 - (c) Test speed:
The speed that will result in 50 km/h or 0.5 V_{max} , whichever is the lower, at the point where the vehicle passes from the low friction to the high friction surface.
 - (d) Brake application:
 - (i) Each *service brake system* control applied separately:
 - (ii) Where ABS is fitted to both brake systems, simultaneous application of both brake controls in addition to (i) above.
 - (e) Brake actuation force:
Hand control = 200 N \pm 20 per cent
Foot control = 350 N \pm 20 per cent
These forces may be increased in order to ensure that the ABS is fully cycling during the stop.
For systems where the brake actuation force fluctuates due to ABS operation, the nominal brake actuation force is the mean value applied for the duration of the stop.
 - (f) Number of stops: until the vehicle meets the performance requirements, with a maximum of 3 stops
 - (g) For each stop, accelerate the vehicle to the test speed and then actuate the brake control before the vehicle reaches the transition from one friction surface to the other.
 - (h) Record the vehicle's continuous deceleration.
- 4.9.7.2. Performance requirements
- (a) When the brakes are tested in accordance with the test procedures set out in paragraph 4.9.7.1., there shall be no wheel lock and the vehicle wheels shall stay within the test lane.
[After passing over the transition point between the low and high friction surfaces, the vehicle deceleration shall increase.] The informal group will conduct a validation test program to assess whether a value can be established for this rise in deceleration and the time that this rise takes.
- 4.9.8. Stops with an ABS electrical failure
- 4.9.8.1. Test conditions and procedure

- (a) With the ABS electrical system disabled, carry out the test set out in paragraph 4.3. (dry stop test – single brake control actuated) applying the conditions relevant to the brake system and vehicle being tested.

4.9.8.2. Performance requirements

When the brakes are tested in accordance with the test procedure set out in paragraph 4.9.8.1.:

- (a) the system shall comply with the failure warning requirements of paragraph 3.1.12. and:
- (b) the minimum requirements for stopping distance or MFDD shall be as specified in column 2 or 3, respectively, under the heading " single brake system, rear wheel braking only" in the table to paragraph 4.3.3.

4.10. Partial failure test – for split service brake systems

4.10.1. General information:

- (a) The test is only applicable to vehicles that are equipped with split service brake systems.
- (b) The test is to confirm the performance of the remaining subsystem in the event of a hydraulic system leakage failure.

4.10.2. Vehicle condition

- (a) The test is applicable to vehicle categories 3-3, 3-4 and 3-5
- (b) Lightly loaded.
- (c) Engine disconnected

4.10.3. Test conditions and procedure

- (a) Initial brake temperature: = 55 °C and = 100 °C
- (b) Test speeds: 50 km/h and 100 km/h or 0.8 Vmax, whichever is lower.
- (c) Brake actuation force:
Hand control = 250 N
Foot control = 400 N
- (d) Number of stops: until the vehicle meets the performance requirements, with a maximum of 6 stops for each test speed.
- (e) Alter the service brake system to induce a complete loss of braking in any one subsystem. Then, for each stop, accelerate the vehicle to the test speed and then apply the brake control under the conditions specified in this paragraph.
- (f) Repeat the test for each subsystem.

4.10.4. Performance requirements

When the brakes are tested in accordance with the test procedure set out in paragraph 4.10.3. above:

- (a) the system shall comply with the failure warning requirements set out in paragraph 3.1.11. and

- (b) the stopping distance (S) shall be $= 0.1 V + 0.0117 V^2$ (where V is the specified test speed in km/h and S is the required stopping distance in metres) or the MFDD shall be $= 3.3 \text{ m/s}^2$

4.11. Power-assisted braking system failure test

4.11.1. General information:

- (a) The test is not conducted when the vehicle is equipped with another separate service brake system.
- (b) The test is to confirm the performance of the service brake system in the event of failure of the power assistance.

4.11.2. Test conditions and procedure

- (a) Carry out the test set out in paragraph 4.3. (dry stop test – single brake control actuated) for each service brake system with the power assistance disabled.

4.11.3. Performance requirements

When the brakes are tested in accordance with the test procedure set out in paragraph 4.11.2., the stopping distance shall be as specified in column 2 or the MFDD shall be as specified in column 3 of the following table:

Column 1	Column 2	Column 3
Vehicle Category	STOPPING DISTANCE(S) (Where V is the specified test speed in km/h and S is the required stopping distance in metres)	MFDD
Single brake system		
3-1	$S = 0.1 V + 0.0143 V^2$	$= 2.7 \text{ m/s}^2$
3-2	$S = 0.1 V + 0.0143 V^2$	$= 2.7 \text{ m/s}^2$
3-3	$S = 0.1 V + 0.0133 V^2$	$= 2.9 \text{ m/s}^2$
3-5	$S = 0.1 V + 0.0105 V^2$	$= 3.6 \text{ m/s}^2$
Vehicles with CBS or SSBS		
ALL	$S = 0.1 V + 0.0154 V^2$	$= 2.5 \text{ m/s}^2$

Note that if the power assistance may be activated by more than one control, the above performance shall be achieved when each control is applied separately.
