



**Economic and
Social
Council**

Distr.
GENERAL

ECE/TRANS/WP.29/GRPE/2006/17
27 March 2006

ENGLISH
Original: ENGLISH AND FRENCH ONLY

ECONOMIC COMMISSION FOR EUROPE

INLAND TRANSPORT COMMITTEE

World Forum for Harmonization of Vehicle Regulations (WP.29)

Working Party on Pollution and Energy (GRPE)

Fifty-second session

Geneva, 6-9 June 2006

Item 1.1. of the provisional agenda

**PROPOSAL FOR A DRAFT GLOBAL TECHNICAL REGULATION (GTR):
TEST PROCEDURE FOR COMPRESSION-IGNITION (C.I.) ENGINES AND POSITIVE-
IGNITION (P.I.) ENGINES FUELLED WITH NATURAL GAS (NG) OR LIQUEFIED
PETROLEUM GAS (LPG) WITH REGARD TO THE EMISSION OF POLLUTANTS
(World-wide harmonized heavy-duty certification (WHDC) procedure)**

Submitted by the expert from the European Commission (EC)

Note: The text reproduced below was prepared by the GRPE informal working group on the World-wide harmonized Heavy-Duty Certification procedure (WHDC). It is based on documents without an official symbol (informal documents Nos. GRPE-50-4, GRPE-50-14 and GRPE-51-6), distributed during the fiftieth and fifty-first GRPE session. Following the agreements reached at the fifty-first GRPE session and the eighteenth meeting of the WHDC informal working group on 28 February 2006, this document presents the final text of the draft WHDC gtr and supersedes ECE/TRANS/WP.29/GRPE/2006/9.

Note: This document is distributed to the Experts on Pollution and Energy only.

GE.06-21685

A. STATEMENT OF TECHNICAL RATIONALE AND JUSTIFICATION

1. TECHNICAL AND ECONOMIC FEASIBILITY

The objective of this proposal is to establish a harmonized global technical regulation (gtr) covering the type-approval procedure for heavy-duty engine exhaust emissions. The basis will be the test procedure developed by the WHDC informal group of GRPE (see the informal document No. 4 distributed during the forty-sixth GRPE session).

Regulations governing the exhaust emissions from heavy-duty engines have been in existence for many years but the test cycles and methods of emissions measurement vary significantly. To be able to correctly determine the impact of a heavy-duty vehicle on the environment in terms of its exhaust pollutant emissions, a laboratory test procedure, and consequently the gtr, needs to be adequately representative of real-world vehicle operation.

The proposed regulation is based on new research into the world-wide pattern of real heavy commercial vehicle use. From the collected data, two representative test cycles, a transient test cycle (WHTC) with both cold and hot start requirements and a hot start steady state test cycle (WHSC), have been created covering typical driving conditions in the European Union (EU), the United States of America, Japan and Australia. Alternative emission measurement procedures have been developed by an expert committee in ISO and have been published in ISO 16183. This standard reflects exhaust emissions measurement technology with the potential for accurately measuring the pollutant emissions from future low emission engines. This work has been the basis for future Japanese and the EU emission legislation. In parallel, substantial work has been undertaken on a different basis in the last several years in the United States of America to make major improvements to the emissions measurement procedures, testing protocols, and regulatory structure for both highway heavy-duty and non-road heavy-duty engines. This work is documented in the rulemaking of the United States of America and was published on 13 July 2005. Some of those new testing protocols are already reflected in this gtr.

It is recognized by the Contracting Parties to the 1998 Agreement that a long-term goal for highway heavy-duty diesel engine testing and non-road diesel engine testing would be gtrs which are similar in structure and substance with respect to measurement equipment, procedures and requirements. Therefore, the Contracting Parties recognize there will be a need in the future to amend this gtr in order to have as much commonality as is possible between the highway heavy-duty diesel gtr and the non-road diesel gtr currently under development. As discussed below, this gtr does not contain emission limit values. When this gtr is amended in the future to include limit values, that may be the appropriate time to reconcile any substantive differences between the world-wide heavy-duty certification procedure (WHDC) gtr and the future gtr on non-road mobile machinery (NRMM). At this stage, the limit values shall be developed by the Contracting Parties according to their own rules of procedure.

The WHTC and WHSC test procedures reflect world-wide on-road heavy-duty engine operation, as closely as possible, and provide a marked improvement in the realism of the test procedure for measuring the emission performance of existing and future heavy-duty engines. In summary, the test procedure was developed so that it would be:

- (a) representative of world-wide on-road vehicle operations,
- (b) able to provide the highest possible level of efficiency in controlling on-road emissions,
- (c) corresponding to state-of-the-art testing, sampling and measurement technology,
- (d) applicable in practice to existing and foreseeable future exhaust emissions abatement technologies,
and
- (e) capable of providing a reliable ranking of exhaust emission levels from different engine types.

At this stage, the gtr is being presented without limit values. In this way, the test procedure can be given a legal status, based on which the Contracting Parties are required to start the process of implementing it into their national law. The gtr contains several options, whose adoption is left to the discretion of the Contracting Parties. Those options are related to the hot soak procedure between the cold and hot WHTC, the weighting factor of cold and hot WHTC, the particulate filter material and size, and the reference fuel. However, these aspects have to be fully harmonized when common limit values are established.

When implementing the test procedure contained in this gtr as part of their national legislation or regulation, Contracting Parties are invited to use limit values which represent at least the same level of severity as their existing regulations, pending the development of harmonized limit values by the Executive Committee (AC.3) under the 1998 Agreement administered by the World Forum for Harmonization of Vehicle Regulations (WP.29). The performance levels (emissions test results) to be achieved in the gtr will, therefore, be discussed on the basis of the most recently agreed legislation in the Contracting Parties, as required by the 1998 Agreement.

2. ANTICIPATED BENEFITS

Heavy commercial vehicles and their engines are increasingly produced for the world market. It is economically inefficient for manufacturers to have to prepare substantially different models in order to meet different emission regulations and methods of measuring emissions, which, in principle, aim at achieving the same objective. To enable manufacturers to develop new models more effectively and within a shorter time, it is desirable that a gtr should be developed. These savings will accrue not only to the manufacturer, but more importantly, to the consumer as well.

However, developing a test procedure just to address the economic question does not completely address the mandate given when work on this gtr was first started. The test procedure must also improve the state of testing heavy-duty engines, and better reflect how heavy-duty engines are used today. Compared to the measurement methods defined in existing legislation of the Contracting Parties to the 1998 Agreement, the testing methods defined in this gtr are much more representative of in-use driving behaviour of commercial vehicles world-wide. It should be noted that the requirements of this gtr should be complemented by the requirements relating to the control of the Off-Cycle Emissions (OCE) and OBD systems.

As a consequence, it can be expected that the application of this gtr for emissions legislation within the Contracting Parties to the 1998 Agreement will result in a higher control of in-use emissions due to the improved correlation of the test methods with in-use driving behaviour.

3. POTENTIAL COST EFFECTIVENESS

Specific cost effectiveness values for this gtr have not been calculated. The decision by the Executive Committee (AC.3) to the 1998 Agreement to move forward with this gtr without limit values is the key reason why this analysis has not been completed. This common agreement has been made knowing that specific cost effectiveness values are not immediately available. However, it is fully expected that this information will be developed, generally, in response to the adoption of this regulation in national requirements and also in support of developing harmonized limit values for the next step in this gtr's development. For example, each Contracting Party adopting this gtr into its national law will be expected to determine the appropriate level of stringency associated with using these new test procedures, with these new values being at least as stringent as comparable existing requirements. Also, experience will be gained by the heavy-duty engine industry as to any costs and cost savings associated with using this test procedure.

The cost and emissions performance data can then be analyzed as part of the next step in this gtr development to determine the cost effectiveness values of the test procedures being adopted today along with the application of harmonized limit values in the future. While there are no values on calculated costs per ton, the belief of the GRPE experts is that there are clear benefits associated with this regulation.

B. TEXT OF REGULATION

1. PURPOSE

This regulation aims at providing a world - wide harmonized method for the determination of the levels of pollutant emissions from engines used in heavy vehicles in a manner which is representative of real world vehicle operation. The results can be the basis for the regulation of pollutant emissions within regional type-approval and certification procedures.

2. SCOPE

This regulation applies to the measurement of the emission of gaseous and particulate pollutants from compression- ignition engines and positive- ignition engines fuelled with natural gas (NG) or liquefied petroleum gas (LPG), used for propelling motor vehicles of categories 1-2 and 2, having a design speed exceeding 25 km/h and having a maximum mass exceeding 3.5 tonnes.

3. DEFINITIONS, SYMBOLS AND ABBREVIATIONS

3.1. Definitions

For the purpose of this regulation,

- 3.1.1. "continuous regeneration" means the regeneration process of an exhaust after-treatment system that occurs either permanently or at least once per WHTC hot start test. Such a regeneration process will not require a special test procedure.
- 3.1.2. "delay time" means the time between the change of the component to be measured at the reference point and a system response of 10 per cent of the final reading (t_{10}). For the gaseous components, this is the transport time of the measured component from the sampling probe to the detector with the sampling probe being defined as the reference point.
- 3.1.3. "deNO_x system" means an exhaust after-treatment system designed to reduce emissions of oxides of nitrogen (NO_x) (e.g. passive and active lean NO_x catalysts, NO_x adsorbers and selective catalytic reduction (SCR) systems).
- 3.1.4. "diesel engine" means an engine which works on the compression-ignition principle.
- 3.1.5. "engine family" means a manufacturer's grouping of engines which, through their design as defined in paragraph 5.2. of this gtr, have similar exhaust emission characteristics; all members of the family must comply with the applicable emission limit values.

- 3.1.6. "engine system" means the engine, the emission control system and the communication interface (hardware and messages) between the engine system electronic control unit(s) (ECU) and any other powertrain or vehicle control unit.
- 3.1.7. "engine type" means a category of engines which do not differ in essential engine characteristics.
- 3.1.8. "exhaust after-treatment system" means a catalyst (oxidation or 3-way), particulate filter, deNOx system, combined deNOx particulate filter or any other emission-reducing device that is installed downstream of the engine. This definition excludes exhaust gas recirculation (EGR), which is considered an integral part of the engine.
- 3.1.9. "full flow dilution method" means the process of mixing dilution air with the total exhaust flow prior to separating a fraction of the diluted exhaust stream for analysis.
- 3.1.10. "gas engine" means an engine which is fuelled with natural gas (NG) or liquefied petroleum gas (LPG).
- 3.1.11. "gaseous pollutants" means carbon monoxide, hydrocarbons and/or non-methane hydrocarbons (assuming a ratio of $\text{CH}_{1.85}$ for diesel, $\text{CH}_{2.525}$ for LPG and $\text{CH}_{2.93}$ for NG, and an assumed molecule $\text{CH}_3\text{O}_{0.5}$ for ethanol fuelled diesel engines), methane (assuming a ratio of CH_4 for NG) and oxides of nitrogen (expressed in nitrogen dioxide (NO_2) equivalent).
- 3.1.12. "high speed (n_{hi})" means the highest engine speed where 70 per cent of the declared maximum power occurs.
- 3.1.13. "low speed (n_{lo})" means the lowest engine speed where 55 per cent of the declared maximum power occurs.
- 3.1.14. "maximum power (P_{max})" means the maximum power in kW as specified by the manufacturer.
- 3.1.15. "maximum torque speed" means the engine speed at which the maximum torque is obtained from the engine, as specified by the manufacturer.
- 3.1.16. "parent engine" means an engine selected from an engine family in such a way that its emissions characteristics will be representative for that engine family.
- 3.1.17. "particulate after-treatment device" means an exhaust after-treatment system designed to reduce emissions of particulate pollutants (PM) through a mechanical, aerodynamic, diffusional or inertial separation.
- 3.1.18. "partial flow dilution method" means the process of separating a part of the raw exhaust from the total exhaust flow, then mixing it with an appropriate amount of dilution air prior to the particulate sampling filter.

- 3.1.19. "particulate matter (PM)" means any material collected on a specified filter medium after diluting exhaust with clean filtered air to a temperature between 315 K (42 °C) and 325 K (52 °C), as measured at a point immediately upstream of the filter; this is primarily carbon, condensed hydrocarbons, and sulphates with associated water.
- 3.1.20. "per cent load" means the fraction of the maximum available torque at an engine speed.
- 3.1.21. "periodic regeneration" means the regeneration process of an exhaust after-treatment system that occurs periodically in typically less than 100 hours of normal engine operation. During cycles where regeneration occurs, emission standards may be exceeded.
- 3.1.22. "ramped steady state test cycle" means a test cycle with a sequence of steady state engine test modes with defined speed, torque, and stability criteria at each mode and defined ramps between these modes (WHSC).
- 3.1.23. "rated speed" means the maximum full load speed allowed by the governor as specified by the manufacturer in his sales and service literature, or, if such a governor is not present, the speed at which the maximum power is obtained from the engine, as specified by the manufacturer in his sales and service literature.
- 3.1.24. "response time" means the difference in time between a rapid change of the component to be measured at the reference point and the appropriate change in the response of the measuring system whereby the change of the measured component is at least 60 per cent full scale (FS) and takes place in less than 0.1 second. The system response time (t_{90}) consists of the delay time to the system and of the rise time of the system. The response time may vary dependent on where the reference point for the change of the component to be measured is defined, either at the sampling probe or directly at the port entrance of the analyzer. In this case, the sampling probe is defined as the reference point (see figure 1).
- 3.1.25. "rise time" means the time between the 10 per cent and 90 per cent response of the final reading ($t_{90} - t_{10}$).
- 3.1.26. "specific emissions" means the mass emissions expressed in g/kWh.
- 3.1.27. "test cycle" means a sequence of test points each with a defined speed and torque to be followed by the engine under steady state (WHSC) or transient operating conditions (WHTC).
- 3.1.28. "transformation time" means the time between the change of the component to be measured at the reference point and a system response of 50 per cent of the final reading (t_{50}) with the sampling probe being defined as the reference point. The transformation time is used for the signal alignment of different measurement instruments.
- 3.1.29. "transient test cycle" means a test cycle with a sequence of normalized speed and torque values that vary relatively quickly with time (WHTC).

- 3.1.30. "useful life" means the relevant period of distance and/or time over which compliance with the relevant gaseous and particulate emission limits has to be assured.

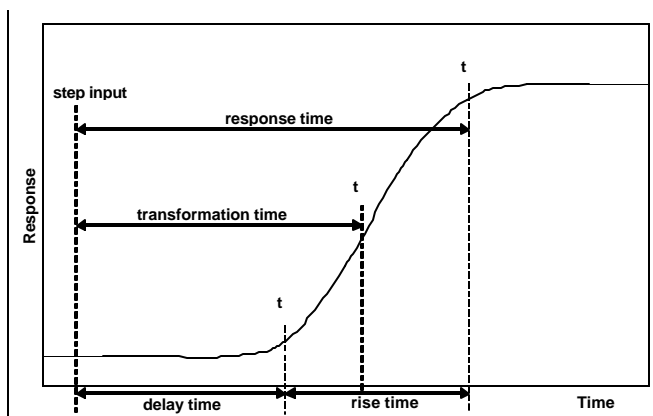

Figure 1:
Definitions of system response

3.2. General symbols

Symbol	Unit	Term
A/F_{st}	-	Stoichiometric air to fuel ratio
c	ppm/Vol per cent	Concentration
c_d	ppm/Vol per cent	Concentration on dry basis
c_w	ppm/Vol per cent	Concentration on wet basis
c_b	ppm/Vol per cent	Background concentration
C_d	-	Discharge coefficient of SSV
d	m	Diameter
d_v	m	Throat diameter of venturi
D_0	m ³ /s	PDP calibration intercept
D	-	Dilution factor
Dt	s	Time interval
e_{gas}	g/kWh	Specific emission of gaseous components
e_{PM}	g/kWh	Specific emission of particulates
e_p	g/kWh	Specific emission during regeneration
e_w	g/kWh	Weighted specific emission
E_{CO2}	per cent	CO ₂ quench of NO _x analyzer
E_E	per cent	Ethane efficiency
E_{H2O}	per cent	Water quench of NO _x analyzer
E_M	per cent	Methane efficiency
E_{NOx}	per cent	Efficiency of NO _x converter
f	Hz	Data sampling rate
f_a	-	Laboratory atmospheric factor
F_s	-	Stoichiometric factor
H_a	g/kg	Absolute humidity of the intake air
H_d	g/kg	Absolute humidity of the dilution air

Symbol	Unit	Term
i	-	Subscript denoting an instantaneous measurement (e.g. 1 Hz)
k_f	-	Fuel specific factor
$k_{h,D}$	-	Humidity correction factor for NO _x for CI engines
$k_{h,G}$	-	Humidity correction factor for NO _x for PI engines
k_r	-	Regeneration factor
$k_{w,a}$	-	Dry to wet correction factor for the intake air
$k_{w,d}$	-	Dry to wet correction factor for the dilution air
$k_{w,e}$	-	Dry to wet correction factor for the diluted exhaust gas
$k_{w,r}$	-	Dry to wet correction factor for the raw exhaust gas
K_V	-	CFV calibration function
λ	-	Excess air ratio
m_d	kg	Mass of the dilution air sample passed through the particulate sampling filters
m_{ed}	kg	Total diluted exhaust mass over the cycle
m_{edf}	kg	Mass of equivalent diluted exhaust gas over the test cycle
m_{ew}	kg	Total exhaust mass over the cycle
m_f	mg	Particulate sample mass collected
$m_{f,d}$	mg	Particulate sample mass of the dilution air collected
m_{gas}	g	Mass of gaseous emissions over the test cycle
m_{PM}	g	Mass of particulate emissions over the test cycle
m_{se}	kg	Exhaust sample mass over the test cycle
m_{sed}	kg	Mass of diluted exhaust gas passing the dilution tunnel
m_{sep}	kg	Mass of diluted exhaust gas passing the particulate collection filters
m_{ssd}	kg	Mass of secondary dilution air
M_a	g/mol	Molar mass of the intake air
M_e	g/mol	Molar mass of the exhaust
M_{gas}	g/mol	Molar mass of gaseous components
n	-	Number of measurements
n_r	-	Number of measurements during regeneration
n	min ⁻¹	Engine rotational speed
n_{hi}	min ⁻¹	High engine speed
n_{lo}	min ⁻¹	Low engine speed
n_{pref}	min ⁻¹	Preferred engine speed
n_p	r/s	PDP pump speed
p_a	kPa	Saturation vapour pressure of engine intake air
p_b	kPa	Total atmospheric pressure
p_d	kPa	Saturation vapour pressure of the dilution air
p_p	kPa	Absolute pressure
p_r	kPa	Water vapour pressure after cooling bath
p_s	kPa	Dry atmospheric pressure
$q_{m_{ad}}$	kg/s	Intake air mass flow rate on dry basis
$q_{m_{aw}}$	kg/s	Intake air mass flow rate on wet basis
$q_{m_{Ce}}$	kg/s	Carbon mass flow rate in the raw exhaust gas
$q_{m_{Cf}}$	kg/s	Carbon mass flow rate into the engine
$q_{m_{Cp}}$	kg/s	Carbon mass flow rate in the partial flow dilution system

Symbol	Unit	Term
$q_{m_{dew}}$	kg/s	Diluted exhaust gas mass flow rate on wet basis
$q_{m_{dw}}$	kg/s	Dilution air mass flow rate on wet basis
$q_{m_{edf}}$	kg/s	Equivalent diluted exhaust gas mass flow rate on wet basis
$q_{m_{ew}}$	kg/s	Exhaust gas mass flow rate on wet basis
$q_{m_{ex}}$	kg/s	Sample mass flow rate extracted from dilution tunnel
q_{mf}	kg/s	Fuel mass flow rate
q_{mp}	kg/s	Sample flow of exhaust gas into partial flow dilution system
$q_{v_{CVS}}$	m ³ /s	CVS volume rate
q_{v_s}	dm ³ /min	System flow rate of exhaust analyzer system
q_{v_t}	cm ³ /min	Tracer gas flow rate
r_d	-	Dilution ratio
r_D	-	Diameter ratio of SSV
r_h	-	Hydrocarbon response factor of the FID
r_m	-	Methanol response factor of the FID
r_p	-	Pressure ratio of SSV
r_s	-	Average sample ratio
ρ	kg/m ³	Density
ρ_e	kg/m ³	Exhaust gas density
s	-	Standard deviation
T	K	Absolute temperature
T_a	K	Absolute temperature of the intake air
t	s	Time
t_{10}	s	Time between step input and 10 per cent of final reading
t_{50}	s	Time between step input and 50 per cent of final reading
t_{90}	s	Time between step input and 90 per cent of final reading
u	-	Ratio between densities of gas component and exhaust gas
V_0	m ³ /r	PDP gas volume pumped per revolution
V_s	dm ³	System volume of exhaust analyzer bench
W_{act}	kWh	Actual cycle work of the test cycle
W_{ref}	kWh	Reference cycle work of the test cycle
X_0	m ³ /r	PDP calibration function

3.3. Symbols and abbreviations for the fuel composition

w_{ALF}	hydrogen content of fuel, per cent mass
w_{BET}	carbon content of fuel, per cent mass
w_{GAM}	sulphur content of fuel, per cent mass
w_{DEL}	nitrogen content of fuel, per cent mass
w_{EPS}	oxygen content of fuel, per cent mass
a	molar hydrogen ratio (H/C)
b	molar carbon ratio (C/C)
g	molar sulphur ratio (S/C)
d	molar nitrogen ratio (N/C)
e	molar oxygen ratio (O/C)
	referring to a fuel $\text{C}_b\text{H}_a\text{O}_c\text{N}_d\text{S}_g$

3.4. Symbols and abbreviations for the chemical components

C1	Carbon 1 equivalent hydrocarbon
CH_4	Methane
C_2H_6	Ethane
C_3H_8	Propane
CO	Carbon monoxide
CO_2	Carbon dioxide
DOP	Di-octylphtate
HC	Hydrocarbons
H_2O	Water
NMHC	Non-methane hydrocarbons
NO_x	Oxides of nitrogen
NO	Nitric oxide
NO_2	Nitrogen dioxide
PM	Particulate matter

3.5. Abbreviations

CFV	Critical Flow Venturi
CLD	Chemiluminescent Detector
CVS	Constant Volume Sampling
de NO_x	NO_x after-treatment system
EGR	Exhaust gas recirculation
FID	Flame Ionization Detector
GC	Gas Chromatograph
HCLD	Heated Chemiluminescent Detector
HFID	Heated Flame Ionization Detector
LPG	Liquefied Petroleum Gas
NDIR	Non-Dispersive Infrared (Analyzer)
NG	Natural Gas
NMC	Non-Methane Cutter

PDP	Positive Displacement Pump
Per cent FS	Per cent of full scale
PFS	Partial Flow System
SSV	Subsonic Venturi
VGT	Variable Geometry Turbine

4. GENERAL REQUIREMENTS

The engine system shall be so designed, constructed and assembled as to enable the engine in normal use to comply with the provisions of this gtr during its useful life, as defined by the Contracting Party, including when installed in the vehicle.

5. PERFORMANCE REQUIREMENTS

When implementing the test procedure contained in this gtr as part of their national legislation, Contracting Parties to the 1998 Agreement are encouraged to use limit values which represent at least the same level of severity as their existing regulations; pending the development of harmonized limit values, by the Executive Committee (AC.3) of the 1998 Agreement, for inclusion in the gtr at a later date.

5.1. Emission of gaseous and particulate pollutants

The emissions of gaseous and particulate pollutants by the engine shall be determined on the WHTC and WHSC test cycles, as described in paragraph 7. The measurement systems shall meet the linearity requirements described in paragraph 9.2. and the specifications described in paragraph 9.3. Annex 3 describes the recommended analytical systems for the gaseous pollutants and the recommended particulate sampling systems.

Other systems or analyzers may be approved by the type approval or certification authority, if it is found that they yield equivalent results in accordance with paragraph 5.1.1.

5.1.1. Equivalency

The determination of system equivalency shall be based on a seven-sample pair (or larger) correlation study between the system under consideration and one of the systems of this gtr.

"Results" refer to the specific cycle weighted emissions value. The correlation testing is to be performed at the same laboratory, test cell, and on the same engine, and is preferred to be run concurrently. The equivalency of the sample pair averages shall be determined by *F*-test and *t*-test statistics as described in annex 4 obtained under the laboratory test cell and the engine conditions described above. Outliers shall be determined in accordance with ISO 5725 and excluded from the database. The systems

to be used for correlation testing shall be subject to the approval by the type approval or certification authority.

5.2. Engine family

5.2.1. General

An engine family is characterized by design parameters. These shall be common to all engines within the family. The engine manufacturer may decide, which engines belong to an engine family, as long as the membership criteria listed in paragraph 5.2.3. are respected. The engine family shall be approved by the type approval or certification authority. The manufacturer shall provide to the type approval or certification authority the appropriate information relating to the emission levels of the members of the engine family.

5.2.2. Special cases

In some cases there may be interaction between parameters. This shall be taken into consideration to ensure that only engines with similar exhaust emission characteristics are included within the same engine family. These cases shall be identified by the manufacturer and notified to the type approval or certification authority. It shall then be taken into account as a criterion for creating a new engine family.

In case of devices or features, which are not listed in paragraph 5.2.3. and which have a strong influence on the level of emissions, this equipment shall be identified by the manufacturer on the basis of good engineering practice, and shall be notified to the type approval or certification authority. It shall then be taken into account as a criterion for creating a new engine family.

In addition to the parameters listed in paragraph 5.2.3., the manufacturer may introduce additional criteria allowing the definition of families of more restricted size. These parameters are not necessarily parameters that have an influence on the level of emissions.

5.2.3. Parameters defining the engine family

5.2.3.1. Combustion cycle

- (a) 2-stroke cycle
- (b) 4-stroke cycle
- (c) Rotary engine
- (d) Others

5.2.3.2. Configuration of the cylinders

5.2.3.2.1. Position of the cylinders in the block

- (a) V
- (b) In line
- (c) Radial
- (d) Others (F, W, etc.)

5.2.3.2.2. Relative position of the cylinders

Engines with the same block may belong to the same family as long as their bore center-to-center dimensions are the same.

5.2.3.3. Main cooling medium

- (a) air
- (b) water
- (c) oil

5.2.3.4. Individual cylinder displacement

5.2.3.4.1. Engine with a unit cylinder displacement = 0.75 dm³

In order for engines with a unit cylinder displacement of = 0.75 dm³ to be considered to belong to the same engine family, the spread of their individual cylinder displacements shall not exceed 15 per cent of the largest individual cylinder displacement within the family.

5.2.3.4.2. Engine with a unit cylinder displacement < 0.75 dm³

In order for engines with a unit cylinder displacement of < 0.75 dm³ to be considered to belong to the same engine family, the spread of their individual cylinder displacements shall not exceed 30 per cent of the largest individual cylinder displacement within the family.

5.2.3.4.3. Engine with other unit cylinder displacement limits

Engines with an individual cylinder displacement that exceeds the limits defined in paragraphs 5.2.3.4.1. and 5.2.3.4.2. may be considered to belong to the same family with the approval of the type approval or certification authority. The approval shall be based on technical elements (calculations, simulations, experimental results etc.) showing that exceeding the limits does not have a significant influence on the exhaust emissions.

5.2.3.5. Method of air aspiration

- (a) naturally aspirated
- (b) pressure charged
- (c) pressure charged with charge cooler

- 5.2.3.6. Fuel type
 - (a) Diesel
 - (b) Natural gas (NG)
 - (c) Liquefied petroleum gas (LPG)
 - (d) Ethanol

- 5.2.3.7. Combustion chamber type
 - (a) Open chamber
 - (b) Divided chamber
 - (c) Other types

- 5.2.3.8. Ignition Type
 - (a) Positive ignition
 - (b) Compression ignition

- 5.2.3.9. Valves and porting
 - (a) Configuration
 - (b) Number of valves per cylinder

- 5.2.3.10. Fuel supply type
 - (a) Liquid fuel supply type
 - (i) Pump and (high pressure) line and injector
 - (ii) In-line or distributor pump
 - (iii) Unit pump or unit injector
 - (iv) Common rail
 - (v) Carburettor(s)
 - (vi) Others
 - (b) Gas fuel supply type
 - (i) Gaseous
 - (ii) Liquid
 - (iii) Mixing units
 - (iv) Others
 - (c) Other types

- 5.2.3.11. Miscellaneous devices
 - (a) Exhaust gas recirculation (EGR)
 - (b) Water injection
 - (c) Air injection
 - (d) Others

5.2.3.12. Electronic control strategy

The presence or absence of an electronic control unit (ECU) on the engine is regarded as a basic parameter of the family.

In the case of electronically controlled engines, the manufacturer shall present the technical elements explaining the grouping of these engines in the same family, i.e. the reasons why these engines can be expected to satisfy the same emission requirements.

These elements can be calculations, simulations, estimations, description of injection parameters, experimental results, etc.

Examples of controlled features are:

- (a) Timing
- (b) Injection pressure
- (c) Multiple injections
- (d) Boost pressure
- (e) VGT
- (f) EGR

5.2.3.13. After-treatment systems

The function and combination of the following devices are regarded as membership criteria for an engine family:

- (a) Oxidation catalyst
- (b) Three-way catalyst
- (c) DeNO_x system with selective reduction of NO_x (addition of reducing agent)
- (d) Other DeNO_x systems
- (e) Particulate trap with passive regeneration
- (f) Particulate trap with active regeneration
- (g) Other particulate traps
- (h) Other devices

When an engine has been certified without after-treatment system, whether as parent engine or as member of the family, then this engine, when equipped with an oxidation catalyst, may be included in the same engine family, if it does not require different fuel characteristics.

If it requires specific fuel characteristics (e.g. particulate traps requiring special additives in the fuel to ensure the regeneration process), the decision to include it in the same family shall be based on technical elements provided by the manufacturer. These elements shall indicate that the expected emission level of the equipped engine complies with the same limit value as the non-equipped engine.

When an engine has been certified with after-treatment system, whether as parent engine or as member of a family, whose parent engine is equipped with the same after-treatment system, then this engine, when equipped without after-treatment system, must not be added to the same engine family.

5.2.4. Choice of the parent engine

5.2.4.1. Compression ignition engines

Once the engine family has been agreed by the type approval or certification authority, the parent engine of the family shall be selected using the primary criterion of the highest fuel delivery per stroke at the declared maximum torque speed. In the event that two or more engines share this primary criterion, the parent engine shall be selected using the secondary criterion of highest fuel delivery per stroke at rated speed.

5.2.4.2. Positive ignition engines

Once the engine family has been agreed by the type approval or certification authority, the parent engine of the family shall be selected using the primary criterion of the largest displacement. In the event that two or more engines share this primary criterion, the parent engine shall be selected using the secondary criterion in the following order of priority:

- (a) the highest fuel delivery per stroke at the speed of declared rated power;
- (b) the most advanced spark timing;
- (c) the lowest EGR rate.

5.2.4.3. Remarks on the choice of the parent engine

The type approval or certification authority may conclude that the worst-case emission rate of the family can best be characterized by testing additional engines. In this case, the parties involved shall have the appropriate information to determine the engines within the family likely to have the highest emissions level.

If engines within the family incorporate other variable features which may be considered to affect exhaust emissions, these features shall also be identified and taken into account in the selection of the parent engine.

If engines within the family meet the same emission values over different useful life periods, this shall be taken into account in the selection of the parent engine.

6. TEST CONDITIONS

6.1. Laboratory test conditions

The absolute temperature (T_a) of the engine air at the inlet to the engine expressed in Kelvin, and the dry atmospheric pressure (p_s), expressed in kPa shall be measured and the parameter f_a shall be determined according to the following provisions. In multi-cylinder engines having distinct groups of intake manifolds, such as in a "Vee" engine configuration, the average temperature of the distinct groups shall be taken. The parameter f_a shall be reported with the test results. For better repeatability and reproducibility of the test results, it is recommended that the parameter f_a be such that: $0.93 \leq f_a \leq 1.07$. Contracting Parties can make the parameter f_a compulsory.

(a) Compression-ignition engines:

Naturally aspirated and mechanically supercharged engines:

$$f_a = \left(\frac{99}{p_s} \right) \times \left(\frac{T_a}{298} \right)^{0.7} \quad (1)$$

Turbocharged engines with or without cooling of the intake air:

$$f_a = \left(\frac{99}{p_s} \right)^{0.7} \times \left(\frac{T_a}{298} \right)^{1.5} \quad (2)$$

(b) Positive ignition engines:

$$f_a = \left(\frac{99}{p_s} \right)^{1.2} \times \left(\frac{T_a}{298} \right)^{0.6} \quad (3)$$

6.2. Engines with charge air-cooling

The charge air temperature shall be recorded and shall be, at the rated speed and full load, within ± 5 K of the maximum charge air temperature specified by the manufacturer. The temperature of the cooling medium shall be at least 293 K (20 °C).

If a test laboratory system or external blower is used, the charge air temperature shall be set to within ± 5 K of the maximum charge air temperature specified by the manufacturer at the rated speed and full load. Coolant temperature and coolant flow rate of the charge air cooler at the above set point shall not be changed for the whole test cycle, unless this results in unrepresentative overcooling of the charge air. The charge air cooler volume shall be based upon good engineering practice and shall be representative of the production engine's in-use installation.

6.3. Engine power

The basis of specific emissions measurement is uncorrected power as defined by the Contracting Parties.

Certain auxiliaries, which are only necessary only for the operation of the vehicle and which may be mounted on the engine should be removed for the test. The following incomplete list is given as an example:

- (a) air compressor for brakes
- (b) power steering compressor
- (c) air conditioning compressor
- (d) pumps for hydraulic actuators

Where auxiliaries have not been removed, the power absorbed by them shall be determined in order to adjust the set values and to calculate the work produced by the engine over the test cycle.

6.4. Engine air intake system

An engine air intake system or a test laboratory system shall be used presenting an air intake restriction within ± 300 Pa of the maximum value specified by the manufacturer for a clean air cleaner at the rated speed and full load.

6.5. Engine exhaust system

An engine exhaust system or a test laboratory system shall be used presenting an exhaust backpressure within ± 650 Pa of the maximum value specified by the manufacturer at the rated speed and full load. The exhaust system shall conform to the requirements for exhaust gas sampling, as set out in paragraphs 8.3.2.2. and 8.3.3.2.

6.6. Engine with after-treatment system

If the engine is equipped with an exhaust after-treatment device, the exhaust pipe shall have the same diameter as found in-use for at least four pipe diameters upstream to the inlet of the beginning of the expansion section containing the after-treatment device. The distance from the exhaust manifold flange or turbocharger outlet to the exhaust after-treatment device shall be the same as in the vehicle configuration or within the distance specifications of the manufacturer. The exhaust backpressure or restriction shall follow the same criteria as above, and may be set with a valve. The after-treatment container may be removed during dummy tests and during engine mapping, and replaced with an equivalent container having an inactive catalyst support.

The emissions measured on the test cycle shall be representative of the emissions in the field. In the case of an engine equipped with a exhaust after-treatment system that

requires the consumption of a reagent, the reagent used for all tests shall be declared by the manufacturer.

For engines equipped with exhaust after-treatment systems that are regenerated on a periodic basis, as described in paragraph 6.6.2., emission results shall be adjusted to account for regeneration events. In this case, the average emission depends on the frequency of the regeneration event in terms of fraction of tests during which the regeneration occurs.

After-treatment systems with continuous regeneration according to paragraph 6.6.1. do not require a special test procedure.

6.6.1. Continuous regeneration

For an exhaust after-treatment system based on a continuous regeneration process the emissions shall be measured on an after-treatment system that has been stabilized so as to result in repeatable emissions behaviour.

The regeneration process shall occur at least once during the WHTC test and the manufacturer shall declare the normal conditions under which regeneration occurs (soot load, temperature, exhaust back-pressure, etc.).

In order to demonstrate that the regeneration process is continuous, at least three WHTC hot start tests shall be conducted. During the tests, exhaust temperatures and pressures shall be recorded (temperature before and after the after-treatment system, exhaust back pressure, etc.).

The after-treatment system is considered to be satisfactory if the conditions declared by the manufacturer occur during the test during a sufficient time and the emission results do not scatter by more than 15 per cent.

If the exhaust after-treatment has a security mode that shifts to a periodic regeneration mode, it should be checked according to paragraph 6.6.2. For that specific case, the applicable emission limits could be exceeded and would not be weighted.

6.6.2. Periodic regeneration

For an exhaust after-treatment based on a periodic regeneration process, the emissions shall be measured on at least three WHTC tests, one during and two outside a regeneration event on a stabilized after-treatment system, and the results be weighted.

The regeneration process shall occur at least once during the WHTC test. The engine may be equipped with a switch capable of preventing or permitting the regeneration process provided this operation has no effect on the original engine calibration.

The manufacturer shall declare the normal parameter conditions under which the regeneration process occurs (soot load, temperature, exhaust back-pressure, etc.) and its duration based on the number of cycles (n_r). The manufacturer shall also provide all the data to determine the number of cycles between two regenerations (n). The exact procedure to determine this time shall be agreed by the type approval or certification authority based upon good engineering judgement.

The manufacturer shall provide an after-treatment system that has been loaded in order to achieve regeneration during a WHTC test. Regeneration shall not occur during this engine-conditioning phase.

Average emissions between regeneration phases shall be determined from the arithmetic mean of several approximately equidistant WHTC hot start tests. As a minimum, at least one WHTC as close as possible prior to a regeneration test and one WHTC immediately after a regeneration test shall be conducted. As an alternative, the manufacturer may provide data to show that the emissions remain constant (± 15 per cent) between regeneration phases. In this case, the emissions of only one WHTC test may be used.

During the regeneration test, all the data needed to detect regeneration shall be recorded (CO or NO_x emissions, temperature before and after the after-treatment system, exhaust back pressure, etc.).

During the regeneration process, the applicable emission limits may be exceeded.

The measured emissions shall be weighted according to paragraph 8.5.2.3., and the final result shall not exceed the applicable emission limits. The test procedure is schematically shown in figure 2.

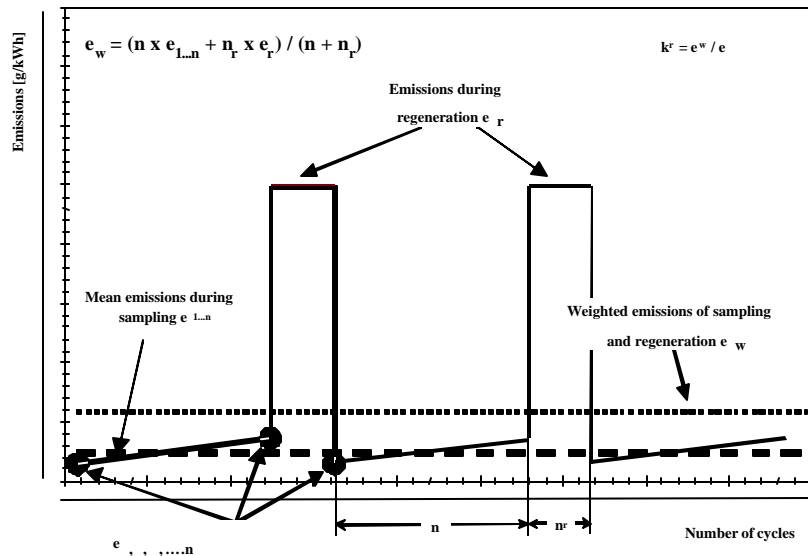

Figure 2:
Scheme of periodic regeneration

6.7. Cooling system

An engine cooling system with sufficient capacity to maintain the engine at normal operating temperatures prescribed by the manufacturer shall be used.

6.8. Lubricating oil

The lubricating oil shall be specified by the manufacturer and be representative of lubricating oil available in the market; the specifications of the lubricating oil used for the test shall be recorded and presented with the results of the test.

6.9. Specification of the reference fuel

The use of one standardized reference fuel has always been considered as an ideal condition for ensuring the reproducibility of regulatory emission testing, and Contracting Parties are encouraged to use such fuel in their compliance testing. However, until performance requirements (i.e. limit values) have been introduced into this gtr, Contracting Parties to the 1998 Agreement are allowed to define their own reference fuel for their national legislation, to address the actual situation of market fuel for vehicles in use.

The appropriate diesel reference fuels of the European Union, the United States of America and Japan listed in annex 2 are recommended to be used for testing. Since fuel characteristics influence the engine exhaust gas emission, the characteristics of the fuel used for the test shall be determined, recorded and declared with the results of the test.

No CNG and LPG reference fuels are listed due to the significant differences in local fuel qualities.

The fuel temperature shall be in accordance with the manufacturers recommendations.

7. TEST PROCEDURES

7.1. Principles of emissions measurement

In this gtr, two measurement principles are described that are functionally equivalent. Both principles may be used for both the WHTC and the WHSC test cycle:

- (a) the gaseous components are measured in the raw exhaust gas on a real time basis, and the particulates are determined using a partial flow dilution system;
- (b) the gaseous components and the particulates are determined using a full flow dilution system (CVS system);
- (c) any combination of the two principles (e.g. raw gaseous measurement and full flow particulate measurement) is permitted.

The engine shall be subjected to the test cycles specified below.

7.2. Transient test cycle WHTC

The transient test cycle WHTC is listed in annex 1 as a second-by-second sequence of normalized speed and torque values applicable to all engines covered by this gr. In order to perform the test on an engine test cell, the normalized values shall be converted to the actual values for the individual engine under test based on the engine-mapping curve. The conversion is referred to as denormalization, and the test cycle so developed as the reference cycle of the engine to be tested. With those reference speed and torque values, the cycle shall be run on the test cell, and the actual speed, torque and power values shall be recorded. In order to validate the test run, a regression analysis between reference and actual speed, torque and power values shall be conducted upon completion of the test.

For calculation of the brake specific emissions, the actual cycle work shall be calculated by integrating actual engine power over the cycle. For cycle validation, the actual cycle work must be within prescribed limits of the cycle work of the reference cycle (reference cycle work).

The gaseous pollutants may be recorded continuously or sampled into a sampling bag. The particulate sample shall be diluted with conditioned ambient air, and collected on a single suitable filter. The WHTC is shown schematically in figure 3.

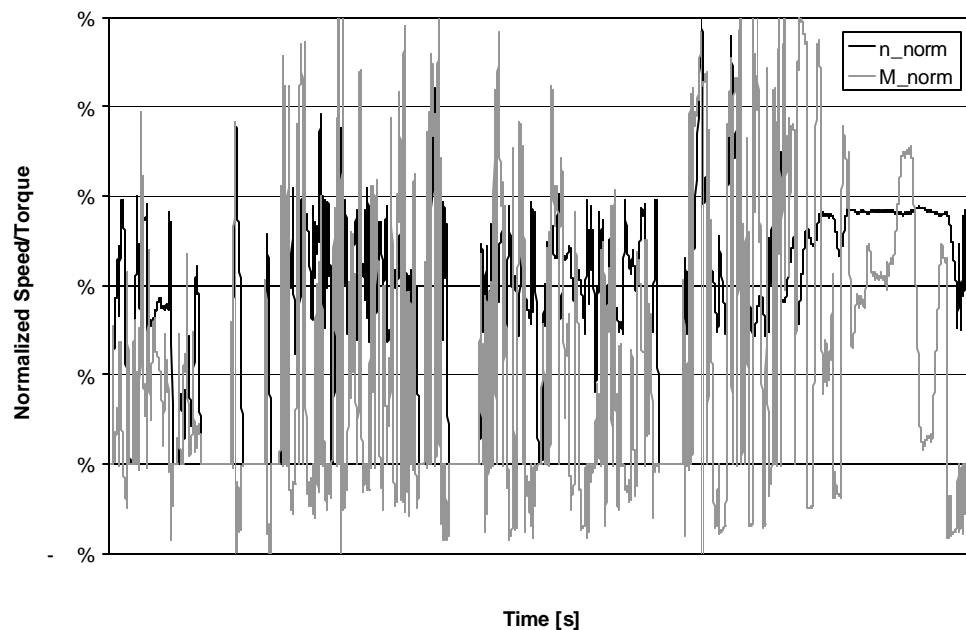

Figure 3:
WHTC test cycle

7.3. Ramped steady state test cycle WHSC

The ramped steady state test cycle WHSC consists of a number of normalized speed and load modes which cover the typical operating range of heavy duty engines. Mode 0 is not run, but is only accounted for mathematically by a weighting factor (WF) of 0.24 and zero emissions and power. The engine shall be operated for the prescribed time in each mode, whereby engine speed and load shall be changed linearly within 20 seconds. In order to validate the test run, a regression analysis between reference and actual speed, torque and power values shall be conducted upon completion of the test.

During each mode and the ramps between the modes the concentration of each gaseous pollutant, exhaust flow and power output shall be determined, and the measured values averaged over the test cycle. The gaseous pollutants may be recorded continuously or sampled into a sampling bag. The particulate sample shall be diluted with conditioned ambient air. One sample over the complete test procedure shall be taken, and collected on a single suitable filter.

For calculation of the brake specific emissions, the actual cycle work shall be calculated by integrating actual engine power over the cycle.

The WHSC is shown in table 1. The weighting factors (WF) are given for reference only. The idle mode is separated in two modes, mode 1 at the beginning and mode 13 at the end of the test cycle.

Mode	Normalized Speed (per cent)	Normalized Load (per cent)	WF for reference	Mode length (s) incl. 20 s ramp
0	Motoring	-	0.24	-
1	0	0	0.17/2	210
2	55	100	0.02	50
3	55	25	0.10	250
4	55	70	0.03	75
5	35	100	0.02	50
6	25	25	0.08	200
7	45	70	0.03	75
8	45	25	0.06	150
9	55	50	0.05	125
10	75	100	0.02	50
11	35	50	0.08	200
12	35	25	0.10	250
13	0	0	0.17/2	210
Sum			1.00	1895

Table 1:
WHSC test cycle

7.4. General test sequence

The following flow chart outlines the general guidance that should be followed during testing. The details of each step are described in the relevant paragraphs. Deviations from the guidance are permitted where appropriate, but the specific requirements of the relevant paragraphs are mandatory.

For the WHTC, the test procedure consists of a cold start test following either natural or forced cool-down of the engine, a hot soak period and a hot start test. Selection of the hot soak period and the weighting factor between cold start test and hot start test shall be decided by the Contracting Parties.

For the WHSC, the test procedure consists of a hot start test following engine preconditioning at WHSC mode 9.

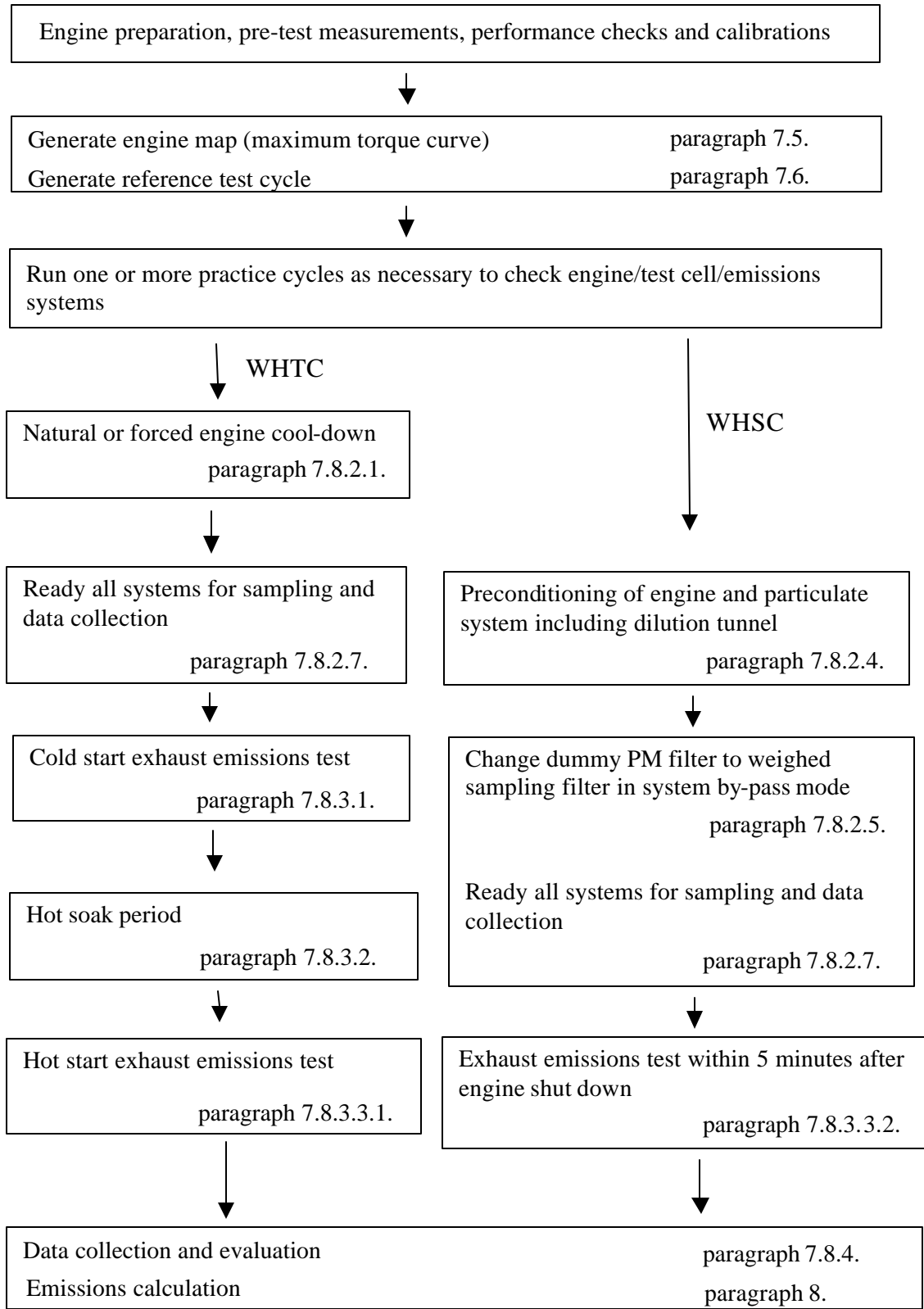

7.5. Engine mapping procedure

For generating the WHTC and WHSC on the test cell, the engine shall be mapped prior to the run of the test cycle for determining the speed vs. torque curve.

7.5.1. Determination of the mapping speed range

The minimum and maximum mapping speeds are defined as follows:

Minimum mapping speed	=	idle speed
Maximum mapping speed	=	$n_{hi} \times 1.02$ or speed where full load torque drops off to zero, whichever is smaller.

7.5.2. Engine mapping curve

The engine shall be warmed up at maximum power in order to stabilize the engine parameters according to the recommendation of the manufacturer and good engineering practice. When the engine is stabilized, the engine mapping shall be performed according to the following procedure.

- (a) The engine shall be unloaded and operated at idle speed.
- (b) The engine shall be operated at full load setting of the injection pump at minimum mapping speed.
- (c) The engine speed shall be increased at an average rate of $8 \pm 1 \text{ min}^{-1}/\text{s}$ from minimum to maximum mapping speed. Engine speed and torque points shall be recorded at a sample rate of at least one point per second.

7.5.3. Alternate mapping

If a manufacturer believes that the above mapping techniques are unsafe or unrepresentative for any given engine, alternate mapping techniques may be used. These alternate techniques must satisfy the intent of the specified mapping procedures to determine the maximum available torque at all engine speeds achieved during the test cycles. Deviations from the mapping techniques specified in this paragraph for reasons of safety or representativeness shall be approved by the type approval or certification authority along with the justification for their use. In no case, however, the torque curve shall be run by descending engine speeds for governed or turbocharged engines.

7.5.4. Replicate tests

An engine need not be mapped before each and every test cycle. An engine shall be remapped prior to a test cycle if:

- (a) an unreasonable amount of time has transpired since the last map, as determined by engineering judgement, or

- (b) physical changes or recalibrations have been made to the engine which potentially affect engine performance.

7.6. Generation of the reference test cycle

7.6.1. Denormalization of engine speed

The speed shall be denormalized using the following equation:

$$\text{Actual speed} = n_{\text{norm}} \times (0.45 \times n_{l_o} + 0.45 \times n_{\text{pref}} + 0.1 \times n_{h_i} - n_{\text{idle}}) \times 2.0327 + n_{\text{idle}} \quad (4)$$

where:

- n_{l_o} is the lowest speed where the power is 55 per cent of maximum power
- n_{pref} is the engine speed where the max. torque integral is 51 per cent of the whole integral
- n_{h_i} is the highest speed where the power is 70 per cent of maximum power.
- n_{idle} is the idle speed

as shown in figure 4.

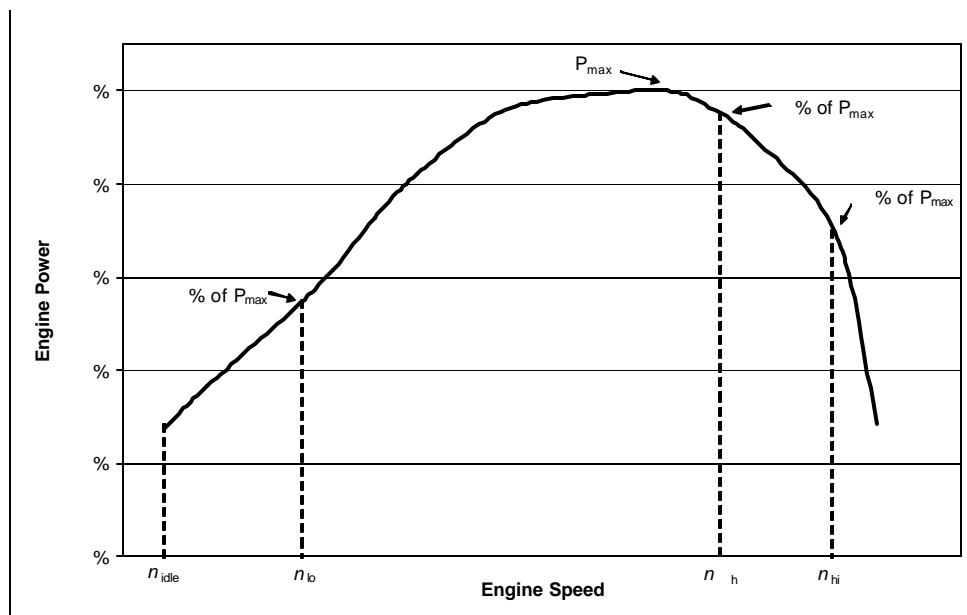

Figure 4:
Definition of test speeds

7.6.1.1. Determination of preferred speed

From the engine mapping curve as determined in accordance with paragraph 7.5.2., the integral of the maximum torque shall be calculated from n_{idle} to n_{95h} . n_{95h} is the highest speed where the power is 95 per cent of maximum power. n_{pref} is then defined as the speed that corresponds to 51 per cent of the whole integral, as shown in figure 5.

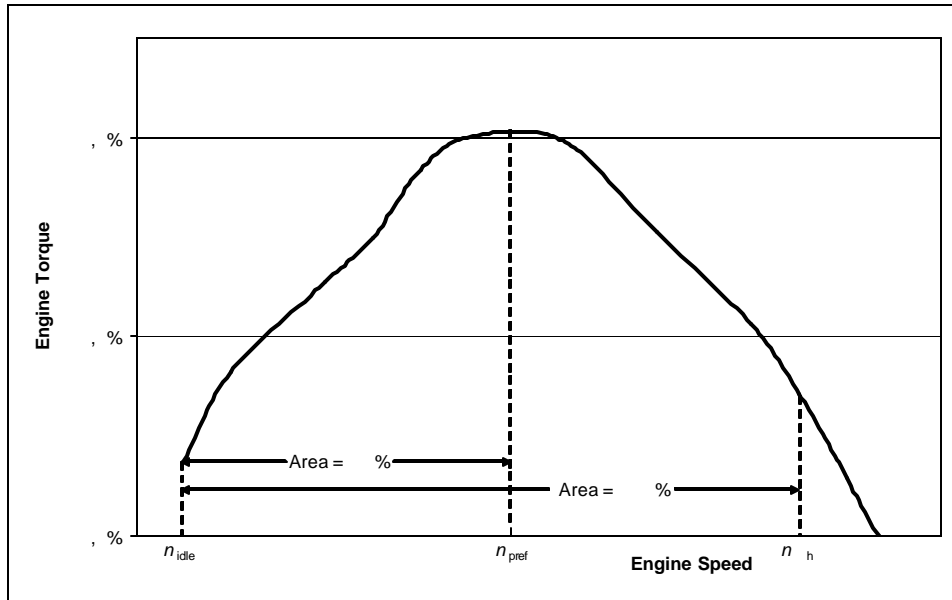

Figure 5:
Definition of n_{pref}

7.6.2. Denormalization of engine torque

The torque values in the engine dynamometer schedule of annex 1 are normalized to the maximum torque at the respective speed. The torque values of the reference cycle shall be denormalized, using the mapping curve determined according to paragraph 7.5.2., as follows:

$$\text{Actual torque} = \frac{\text{per cent torque} \times \text{max. torque}}{100} \quad (5)$$

for the respective actual speed as determined in paragraph 7.6.1.

7.6.3. Example of denormalization procedure

As an example, the following test point shall be denormalized:

$$\begin{aligned} \text{per cent speed} &= 43 \text{ per cent} \\ \text{per cent torque} &= 82 \text{ per cent} \end{aligned}$$

Given the following values:

$$\begin{aligned} n_{lo} &= 1,015 \text{ min}^{-1} \\ n_{hi} &= 2,200 \text{ min}^{-1} \\ n_{pref} &= 1,300 \text{ min}^{-1} \\ n_{idle} &= 600 \text{ min}^{-1} \end{aligned}$$

results in:

$$\begin{aligned} \text{actual speed} &= \frac{43 \times (0.45 \times 1,015 + 0.45 \times 1,300 + 0.1 \times 2,200 - 600) \times 2.0327}{100} + 600 \\ &= 1,178 \text{ min}^{-1} \end{aligned}$$

With the maximum torque of 700 Nm observed from the mapping curve at 1,178 min^{-1}

$$\text{actual torque} = \frac{82 \times 700}{100} = 574 \text{ Nm}$$

7.7. Validation of the test run

7.7.1. Calculation of the cycle work

Before calculating the cycle work, any points recorded during engine starting shall be omitted. The cycle work W_{act} (kWh) shall be calculated based on engine feedback speed and torque values. The reference cycle work W_{ref} (kWh) shall be calculated based on engine reference speed and torque values. The actual cycle work W_{act} is used for comparison to the reference cycle work W_{ref} and for calculating the brake specific emissions (see paragraph 8.5.2.1.).

The same methodology shall be used for integrating both reference and actual engine power. If values are to be determined between adjacent reference or adjacent measured values, linear interpolation shall be used. In integrating the actual cycle work, any negative torque values shall be set equal to zero and included. If integration is performed at a frequency of less than 5 Hz, and if, during a given time segment, the torque value changes from positive to negative or negative to positive, the negative portion shall be computed and set equal to zero. The positive portion shall be included in the integrated value.

W_{act} shall be between 85 per cent and 105 per cent of W_{ref} .

7.7.2. Validation statistics of the test cycle

Linear regressions of the actual values on the reference values shall be performed for speed, torque and power.

To minimize the biasing effect of the time lag between the actual and reference cycle values, the entire engine speed and torque actual signal sequence may be advanced or delayed in time with respect to the reference speed and torque sequence. If the actual signals are shifted, both speed and torque must be shifted the same amount in the same direction.

The method of least squares shall be used, with the best-fit equation having the form:

$$y = mx + b \quad (6)$$

where:

- y = actual value of speed (min^{-1}), torque (Nm), or power (kW)
- m = slope of the regression line
- x = reference value of speed (min^{-1}), torque (Nm), or power (kW)
- b = y intercept of the regression line

The standard error of estimate (SEE) of y on x and the coefficient of determination (r^2) shall be calculated for each regression line.

It is recommended that this analysis be performed at 1 Hz. For a test to be considered valid, the criteria of table 2 must be met.

	Speed	Torque	Power
Standard error of estimate (SEE) of y on x	max. 100 min^{-1}	max. 13 per cent of maximum engine torque	max. 8 per cent of maximum engine power
Slope of the regression line, m	0.95 to 1.03	0.83 - 1.03	0.89 - 1.03
Coefficient of determination, r^2	min. 0.970	min. 0.850	Min. 0.910
y intercept of the regression line, b	$\pm 50 \text{ min}^{-1}$	$\pm 20 \text{ Nm}$ or ± 2 per cent of maximum torque whichever is greater	$\pm 4 \text{ kW}$ or ± 2 per cent of maximum power whichever is greater

Table 2:
Regression line tolerances

For regression purposes only, point deletions are permitted where noted in table 3 before doing the regression calculation. However, those points shall not be deleted for the calculation of cycle work and emissions. An idle point is defined as a point having a normalized reference torque of 0 per cent and a normalized reference speed of 0 per cent. Point deletion may be applied to the whole or to any part of the cycle.

Condition	Points to be deleted
First 6 ± 1 seconds	Speed, torque, power
Full load demand and actual torque < 95 per cent reference torque	Torque and/or power
Full load demand and actual speed < 95 per cent reference speed	Speed and/or power
No load demand and actual torque > reference torque	Torque and/or power
No load demand and actual torque > ± 2 per cent of maximum torque (idle point)	Speed and/or power
No load demand and reference torque < 0 per cent (motoring point)	Torque and/or power

Table 3:

Permitted point deletions from regression analysis

7.8. Emissions Test Run

7.8.1. Introduction

The emissions to be measured from the exhaust of the engine include the gaseous components (carbon monoxide, total hydrocarbons or non-methane hydrocarbons and oxides of nitrogen), and the particulates. Additionally, carbon dioxide is often used as a tracer gas for determining the dilution ratio of partial and full flow dilution systems.

The above pollutants shall be examined during the prescribed test cycles. The concentrations of the gaseous components shall be determined over the cycle either in the raw exhaust gas by integration of the analyzer signal, or in the diluted exhaust gas of a CVS full flow dilution system by integration or by bag sampling. For particulates, a proportional sample shall be collected from the diluted exhaust gas on a specified filter by either partial flow dilution or full flow dilution. Depending on the method used, the diluted or undiluted exhaust gas flow rate shall be determined over the cycle to calculate the mass emission values of the pollutants. The mass emission values shall be related to the engine work, as calculated in accordance with paragraph 7.7.1., to get the grams of each pollutant emitted per kilowatt hour.

7.8.2. Pre-test procedures

Pre-test engine measurements, pre-test engine performance checks and pre-test system calibrations shall be made prior to the engine mapping procedure in line with the general test sequence shown in paragraph 7.4.

7.8.2.1. Engine cool-down (cold start test only)

A natural or forced cool-down procedure may be applied. For forced cool-down, good engineering judgment shall be used to set up systems to send cooling air across the engine, to send cool oil through the engine lubrication system, to remove heat from the coolant through the engine cooling system, and to remove heat from an exhaust after-treatment system. In the case of a forced after-treatment cool down, cooling air shall not

be applied until the after-treatment system has cooled below its catalytic activation temperature. Any cooling procedure that results in unrepresentative emissions is not permitted.

7.8.2.2. Preparation of the sampling filters

At least one hour before the test, each filter shall be placed in a petri dish, which is protected against dust contamination and allows air exchange, and placed in a weighing chamber for stabilization. At the end of the stabilization period, each filter shall be weighed and the tare weight shall be recorded. The filter shall then be stored in a closed petri dish or sealed filter holder until needed for testing. The filter shall be used within eight hours of its removal from the weighing chamber.

7.8.2.3. Installation of the measuring equipment

The instrumentation and sample probes shall be installed as required. The tailpipe shall be connected to the full flow dilution system, if used.

7.8.2.4. Preconditioning the dilution system and the engine (WHSC only)

The dilution system and the engine shall be started and warmed up. After warm-up, the engine and sampling system shall be preconditioned by operating the engine at mode 9 for a minimum of 10 minutes while simultaneously operating either the partial flow dilution system or the full flow dilution and secondary dilution system. Dummy particulate emissions samples may be collected. Those sample filters need not be stabilized or weighed, and may be discarded. Flow rates shall be set at the approximate flow rates selected for testing.

7.8.2.5. Starting the particulate sampling system

The particulate sampling system shall be started and operated on by-pass. The particulate background level of the dilution air may be determined by sampling the dilution air prior to the entrance of the exhaust gas into the dilution tunnel. The measurement may be done prior to or after the test. If the measurement is done both at the beginning and at the end of the cycle, the values may be averaged. If a different sampling system is used for background measurement, the measurement shall be done in parallel to the test run.

7.8.2.6. Adjustment of the dilution system

The total diluted exhaust gas flow of a full flow dilution system or the diluted exhaust gas flow through a partial flow dilution system shall be set to eliminate water condensation in the system, and to obtain a filter face temperature between 315 K (42 °C) and 325 K (52 °C).

7.8.2.7. Checking the analyzers

The emission analyzers shall be set at zero and spanned. If sample bags are used, they shall be evacuated.

7.8.3. Engine starting procedure

7.8.3.1. Cold start test (WHTC only)

The cold-start test shall be started when the temperatures of the engine's lubricant, coolant, and after-treatment systems are all between 293 and 303 K (20 and 30 °C). The engine shall be started using one of the following methods:

- (a) the engine shall be started as recommended in the owners manual using a production starter motor and adequately charged battery or a suitable power supply; or
- (b) the engine shall be started by using the dynamometer. The engine shall be motored within ± 25 per cent of its typical in-use cranking speed. Cranking shall be stopped within 1 second of starting the engine. If the engine does not start after 15 seconds of cranking, cranking shall be stopped and the reason for the failure to start determined, unless the owners manual or the service-repair manual describes the longer cranking time as normal.

7.8.3.2. Hot soak period (WHTC only)

Immediately upon completion of the cold start test, the engine shall be conditioned for the hot start test by using one of the following options:

- (a) 5 minutes hot soak period
- (b) 20 minutes hot soak period

The option shall be selected by the Contracting Parties.

7.8.3.3. Hot start test

7.8.3.3.1. WHTC

The engine shall be started at the end of the hot soak period as defined in paragraph 7.8.3.2. using the starting methods given in paragraph 7.8.3.1.

7.8.3.3.2. WHSC

5 minutes after completion of preconditioning at mode 9 as described in paragraph 7.8.2.4., the engine shall be started according to the manufacturer's recommended starting procedure in the owner's manual, using either a production starter motor or the dynamometer in accordance with paragraph 7.8.3.1.

7.8.4. Cycle run

7.8.4.1. Test sequence

The test sequence shall commence at the start of the engine.

The WHTC shall be performed according to the reference cycle as set out in paragraph 7.2. Engine speed and torque command set points shall be issued at 5 Hz (10 Hz recommended) or greater. The set points shall be calculated by linear interpolation between the 1 Hz set points of the reference cycle. Actual engine speed and torque shall be recorded at least once every second during the test cycle (1 Hz), and the signals may be electronically filtered.

The WHSC shall be performed according to the order of test modes listed in table 1 of paragraph 7.3.

7.8.4.2. Analyzer response

At the start of the test sequence, the measuring equipment shall be started, simultaneously:

- (a) start collecting or analyzing dilution air, if a full flow dilution system is used;
- (b) start collecting or analyzing raw or diluted exhaust gas, depending on the method used;
- (c) start measuring the amount of diluted exhaust gas and the required temperatures and pressures;
- (d) start recording the exhaust gas mass flow rate, if raw exhaust gas analysis is used;
- (e) start recording the feedback data of speed and torque of the dynamometer.

If raw exhaust measurement is used, the emission concentrations (HC, CO and NO_x) and the exhaust gas mass flow rate shall be measured continuously and stored with at least 2 Hz on a computer system. All other data may be recorded with a sample rate of at least 1 Hz. For analogue analyzers the response shall be recorded, and the calibration data may be applied online or offline during the data evaluation.

If a full flow dilution system is used, HC and NO_x shall be measured continuously in the dilution tunnel with a frequency of at least 2 Hz. The average concentrations shall be determined by integrating the analyzer signals over the test cycle. The system response time shall be no greater than 20 s, and shall be coordinated with CVS flow fluctuations and sampling time/test cycle offsets, if necessary. CO, CO₂, and NMHC shall be determined by integration of continuous measurement signals or by analyzing the concentrations in the sample bag, collected over the cycle. The concentrations of the gaseous pollutants in the dilution air shall be determined by integration or by collecting into the background bag. All other parameters that need to be measured shall be recorded with a minimum of one measurement per second (1 Hz).

7.8.4.3. Particulate sampling

At the start of the test sequence, the particulate sampling system shall be switched from bypass to collecting particulates.

If a partial flow dilution system is used, the sample pump(s) shall be controlled, so that the flow rate through the particulate sample probe or transfer tube is maintained proportional to the exhaust mass flow rate.

If a full flow dilution system is used, the sample pump(s) shall be adjusted so that the flow rate through the particulate sample probe or transfer tube is maintained at a value within ± 5 per cent of the set flow rate. If flow compensation (i.e., proportional control of sample flow) is used, it must be demonstrated that the ratio of main tunnel flow to particulate sample flow does not change by more than ± 5 per cent of its set value (except for the first 10 seconds of sampling). The average temperature and pressure at the gas meter(s) or flow instrumentation inlet shall be recorded. If the set flow rate cannot be maintained over the complete cycle (within ± 5 per cent) because of high particulate loading on the filter, the test shall be voided. The test shall be rerun using a lower flow rate.

7.8.4.4. Engine stalling and equipment malfunction

If the engine stalls anywhere during the cold start test of the WHTC or during the WHSC, the test shall be voided. The engine shall be preconditioned and restarted according to the requirements of paragraph 7.8.3.1., and the test repeated.

If the engine stalls anywhere during the hot start test of the WHTC, the test shall be voided. The engine shall be soaked according to paragraph 7.8.3.2., and the hot start test repeated. In this case, the cold start test need not be repeated.

If a malfunction occurs in any of the required test equipment during the test cycle, the test shall be voided and repeated in line with the above provisions in dependence of the test cycle.

7.8.4.5. Operations after test

At the completion of the test, the measurement of the exhaust gas mass flow rate, the diluted exhaust gas volume, the gas flow into the collecting bags and the particulate sample pump shall be stopped. For an integrating analyzer system, sampling shall continue until system response times have elapsed.

The concentrations of the collecting bags, if used, shall be analyzed as soon as possible and in any case not later than 20 minutes after the end of the test cycle.

After the emission test, a zero gas and the same span gas shall be used for re-checking the analyzers. The test will be considered acceptable if the difference between the pre-test and post-test results is less than 2 per cent of the span gas value.

The particulate filters shall be returned to the weighing chamber no later than one hour after completion of the test. They shall be conditioned in a petri dish, which is protected against dust contamination and allows air exchange, for at least one hour, and then weighed. The gross weight of the filters shall be recorded.

8. EMISSION MEASUREMENT AND CALCULATION

The final test result shall be rounded in one step to the number of places to the right of the decimal point indicated by the applicable emission standard plus one additional significant figure, in accordance with ASTM E 29-04. No rounding of intermediate values leading to the final break-specific emission result is permitted.

8.1. Dry/wet correction

If the emissions are not measured on a wet basis, the measured concentration shall be converted to a wet basis according to the following equation:

$$c_w = k_w \times c_d \quad (7)$$

where:

c_w is the wet concentration in ppm or per cent volume

c_d is the dry concentration in ppm or per cent volume

k_w is the dry/wet correction factor

8.1.1. Raw exhaust gas

$$k_{w,a} = \left(1 - \frac{1.2442 \times H_a + 111.19 \times w_{ALF} \times \frac{q_{mfi}}{q_{mad,i}}}{773.4 + 1.2442 \times H_a + \frac{q_{mfi}}{q_{mad,i}} \times k_f \times 1,000} \right) \times 1.008 \quad (8)$$

or

$$k_{w,a} = \left(1 - \frac{1.2442 \times H_a + 111.19 \times w_{ALF} \times \frac{q_{mfi}}{q_{mad,i}}}{773.4 + 1.2442 \times H_a + \frac{q_{mfi}}{q_{mad,i}} \times k_f \times 1,000} \right) \left/ \left(1 - \frac{p_f}{p_b} \right) \right. \quad (9)$$

or

$$k_{w,a} = \left(\frac{1}{1 + \mathbf{a} \times 0.005 \times (c_{CO_2} + c_{CO})} - k_{w1} \right) \times 1.008 \quad (10)$$

with

$$k_f = 0.055594 \times w_{ALF} + 0.0080021 \times w_{DEL} + 0.0070046 \times w_{EPS} \quad (11)$$

and

$$k_{w1} = \frac{1.608 \times H_a}{1,000 + (1.608 \times H_a)} \quad (12)$$

where:

- H_a is the intake air humidity, g water per kg dry air
- w_{ALF} is the hydrogen content of the fuel, per cent mass
- $q_{mf,i}$ is the instantaneous fuel mass flow rate, kg/s
- $q_{mad,I}$ is the instantaneous dry intake air mass flow rate, kg/s
- p_r is the water vapour pressure after cooling bath, kPa
- p_b is the total atmospheric pressure, kPa
- w_{DEL} is the nitrogen content of the fuel, per cent mass
- w_{EPS} is the oxygen content of the fuel, per cent mass
- \mathbf{a} is the molar hydrogen ratio of the fuel
- c_{CO_2} is the dry CO_2 concentration, per cent
- c_{CO} is the dry CO concentration, per cent

Equations (8) and (9) are principally identical with the factor 1.008 in equations (8) and (11) being an approximation for the more accurate denominator in equation (9).

8.1.2. Diluted exhaust gas

$$k_{w,e} = \left[\left(1 - \frac{\mathbf{a} \times c_{CO_2w}}{200} \right) - k_{w2} \right] \times 1.008 \quad (13)$$

or

$$k_{w,e} = \left[\left(\frac{(1 - k_{w2})}{1 + \frac{\mathbf{a} \times c_{CO_2d}}{200}} \right) \right] \times 1.008 \quad (14)$$

with

$$k_{w2} = \frac{1.608 \times \left[H_d \times \left(1 - \frac{1}{D} \right) + H_a \times \left(\frac{1}{D} \right) \right]}{1,000 + \left\{ 1.608 \times \left[H_d \times \left(1 - \frac{1}{D} \right) + H_a \times \left(\frac{1}{D} \right) \right] \right\}} \quad (15)$$

where:

- a** is the molar hydrogen ratio of the fuel
 c_{CO2w} is the wet CO₂ concentration, per cent
 c_{CO2d} is the dry CO₂ concentration, per cent
 H_d is the dilution air humidity, g water per kg dry air
 H_a is the intake air humidity, g water per kg dry air
 D is the dilution factor (see paragraph 8.4.2.4.2.)

8.1.3. Dilution air

$$k_{w,d} = (1 - k_{w3}) \times 1.008 \quad (16)$$

with

$$k_{w3} = \frac{1.608 \times H_d}{1,000 + (1.608 \times H_d)} \quad (17)$$

where:

- H_d is the dilution air humidity, g water per kg dry air

8.2. NO_x correction for humidity and temperature

As the NO_x emission depends on ambient air conditions, the NO_x concentration shall be corrected for humidity with the factors given in paragraph 8.2.1. or 8.2.2. The intake air humidity H_a may be derived from relative humidity measurement, dew point measurement, vapour pressure measurement or dry/wet bulb measurement using generally accepted equation.

8.2.1. Compression-ignition engines

$$k_{h,D} = \frac{15.698 \times H_a}{1,000} + 0.832 \quad (18)$$

where:

- H_a is the intake air humidity, g water per kg dry air

8.2.2. Positive ignition engines

$$k_{h,G} = 0.6272 + 44.030 \times 10^{-3} \times H_a - 0.862 \times 10^{-3} \times H_a^2 \quad (19)$$

where:

H_a is the intake air humidity, g water per kg dry air

8.3. Partial flow dilution (PFS) and raw gaseous measurement

The instantaneous concentration signals of the gaseous components are used for the calculation of the mass emissions by multiplication with the instantaneous exhaust mass flow rate. The exhaust mass flow rate may be measured directly, or calculated using the methods of intake air and fuel flow measurement, tracer method or intake air and air/fuel ratio measurement. Special attention shall be paid to the response times of the different instruments. These differences shall be accounted for by time aligning the signals. For particulates, the exhaust mass flow rate signals are used for controlling the partial flow dilution system to take a sample proportional to the exhaust mass flow rate. The quality of proportionality is checked by applying a regression analysis between sample and exhaust flow. The complete test set up is schematically shown in figure 6.

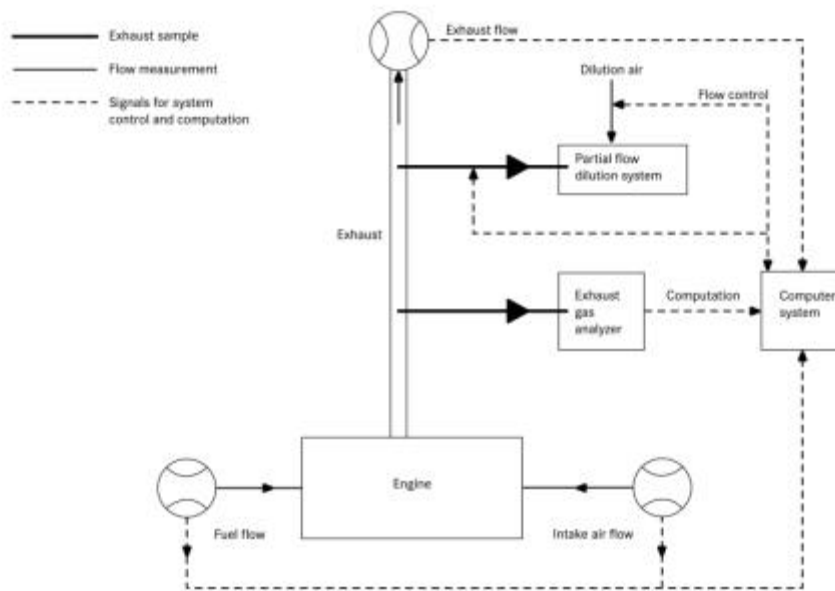

Figure 6:
Scheme of raw/partial flow measurement system

8.3.1. Determination of exhaust gas mass flow

8.3.1.1. Introduction

For calculation of the emissions in the raw exhaust gas and for controlling of a partial flow dilution system, it is necessary to know the exhaust gas mass flow rate. For the

determination of the exhaust mass flow rate, either of the methods described in paragraphs 8.3.1.3 to 8.3.1.6 may be used.

8.3.1.2. Response time

For the purpose of emissions calculation, the response time of either method described in paragraphs 8.3.1.3 to 8.3.1.6 shall be equal to or less than the requirement for the analyzer response time of = 10 s, as defined in paragraph 9.3.5. When using a NMC for the measurement of NMHC, the system response time may exceed 10 s.

For the purpose of controlling of a partial flow dilution system, a faster response is required. For partial flow dilution systems with online control, the response time shall be = 0.3 s. For partial flow dilution systems with look ahead control based on a pre-recorded test run, the response time of the exhaust flow measurement system shall be = 5 s with a rise time of = 1 s. The system response time shall be specified by the instrument manufacturer. The combined response time requirements for the exhaust gas flow and partial flow dilution system are indicated in paragraph 8.3.3.3.

8.3.1.3. Direct measurement method

Direct measurement of the instantaneous exhaust flow shall be done by systems, such as:

- (a) pressure differential devices, like flow nozzle, (details see ISO 5167)
- (b) ultrasonic flowmeter
- (c) vortex flowmeter

Precautions shall be taken to avoid measurement errors which will impact emission value errors. Such precautions include the careful installation of the device in the engine exhaust system according to the instrument manufacturers' recommendations and to good engineering practice. Especially, engine performance and emissions shall not be affected by the installation of the device.

The flowmeters shall meet the linearity requirements of paragraph 9.2.

8.3.1.4. Air and fuel measurement method

This involves measurement of the airflow and the fuel flow with suitable flowmeters. The calculation of the instantaneous exhaust gas flow shall be as follows:

$$q_{m_{ew,i}} = q_{m_{aw,i}} + q_{m_{f,i}} \quad (20)$$

where:

$q_{m_{ew,i}}$ is the instantaneous exhaust mass flow rate, kg/s

$q_{m_{aw,i}}$ is the instantaneous intake air mass flow rate, kg/s

q_{m_i} is the instantaneous fuel mass flow rate, kg/s

The flowmeters shall meet the linearity requirements of paragraph 9.2., but shall be accurate enough to also meet the linearity requirements for the exhaust gas flow.

8.3.1.5. Tracer measurement method

This involves measurement of the concentration of a tracer gas in the exhaust.

A known amount of an inert gas (e.g. pure helium) shall be injected into the exhaust gas flow as a tracer. The gas is mixed and diluted by the exhaust gas, but shall not react in the exhaust pipe. The concentration of the gas shall then be measured in the exhaust gas sample.

In order to ensure complete mixing of the tracer gas, the exhaust gas sampling probe shall be located at least 1 m or 30 times the diameter of the exhaust pipe, whichever is larger, downstream of the tracer gas injection point. The sampling probe may be located closer to the injection point if complete mixing is verified by comparing the tracer gas concentration with the reference concentration when the tracer gas is injected upstream of the engine.

The tracer gas flow rate shall be set so that the tracer gas concentration at engine idle speed after mixing becomes lower than the full scale of the trace gas analyzer.

The calculation of the exhaust gas flow shall be as follows:

$$q_{m_{ew,i}} = \frac{q_{vt} \times r_e}{60 \times (c_{mix,i} - c_a)} \quad (21)$$

where:

$q_{m_{ew,i}}$ is the instantaneous exhaust mass flow rate, kg/s

q_{vt} is tracer gas flow rate, cm³/min

$c_{mix,i}$ is the instantaneous concentration of the tracer gas after mixing, ppm

r_e is the density of the exhaust gas, kg/m³ (cf. table 4)

c_b is the background concentration of the tracer gas in the intake air, ppm

The background concentration of the tracer gas (c_b) may be determined by averaging the background concentration measured immediately before the test run and after the test run.

When the background concentration is less than 1 per cent of the concentration of the tracer gas after mixing ($c_{mix,i}$) at maximum exhaust flow, the background concentration may be neglected.

The total system shall meet the linearity requirements for the exhaust gas flow of paragraph 9.2.

8.3.1.6. Airflow and air to fuel ratio measurement method

This involves exhaust mass calculation from the airflow and the air to fuel ratio. The calculation of the instantaneous exhaust gas mass flow is as follows:

$$q_{mewi} = q_{maw,i} \times \left(1 + \frac{1}{A/F_{st} \times I_i} \right) \quad (22)$$

with

$$A/F_{st} = \frac{138.0 \times \left(\beta + \frac{a}{4} - \frac{e}{2} + ? \right)}{12.011 \times \beta + 1.00794 \times a + 15.9994 \times e + 14.0067 \times d + 32.065 \times ?} \quad (23)$$

$$I_i = \frac{\beta \times \left(100 - \frac{c_{COd} \times 10^{-4}}{2} - c_{HCw} \times 10^{-4} \right) + \left(\frac{a}{4} \times \frac{1 - \frac{2 \times c_{COd} \times 10^{-4}}{3.5 \times c_{CO2d}}}{1 + \frac{c_{CO} \times 10^{-4}}{3.5 \times c_{CO2d}}} - \frac{e}{2} - \frac{d}{2} \right) \times (c_{CO2d} + c_{COd} \times 10^{-4})}{4.764 \times \left(\beta + \frac{a}{4} - \frac{e}{2} + ? \right) \times (c_{CO2d} + c_{COd} \times 10^{-4} + c_{HCw} \times 10^{-4})} \quad (24)$$

where:

$q_{mew,i}$ is the instantaneous exhaust mass flow rate, kg/s

$q_{maw,i}$ is the instantaneous intake air mass flow rate, kg/s

A/F_{st} is the stoichiometric air to fuel ratio, kg/kg

I_i is the instantaneous excess air ratio

c_{CO2d} is the dry CO₂ concentration, per cent

c_{COd} is the dry CO concentration, ppm

c_{HCw} is the wet HC concentration, ppm

Airflowmeter and analyzers shall meet the linearity requirements of paragraph 9.2., and the total system shall meet the linearity requirements for the exhaust gas flow of paragraph 9.2.

If an air to fuel ratio measurement equipment such as a zirconia type sensor is used for the measurement of the excess air ratio, it shall meet the specifications of paragraph 9.3.2.7.

8.3.2. Determination of the gaseous components

8.3.2.1. Introduction

The gaseous components in the raw exhaust gas emitted by the engine submitted for testing shall be measured with the measurement and sampling systems described in paragraph 9.3. and annex 3. The data evaluation is described in paragraph 8.3.2.3.

Two calculation procedures are described in paragraphs 8.3.2.4. and 8.3.2.5., which are equivalent for the reference fuels of annex 2. The procedure in paragraph 8.3.2.4. is more straightforward, since it uses tabulated u values for the ratio between component and exhaust gas density. The procedure in paragraph 8.3.2.5. is more accurate for fuel qualities that deviate from annex 2, but requires elementary analysis of the fuel composition.

8.3.2.2. Sampling for gaseous emissions

The gaseous emissions sampling probes shall be fitted at least 0.5 m or 3 times the diameter of the exhaust pipe - whichever is the larger - upstream of the exit of the exhaust gas system but sufficiently close to the engine as to ensure an exhaust gas temperature of at least 343 K (70 °C) at the probe.

In the case of a multi-cylinder engine with a branched exhaust manifold, the inlet of the probe shall be located sufficiently far downstream so as to ensure that the sample is representative of the average exhaust emissions from all cylinders. In multi-cylinder engines having distinct groups of manifolds, such as in a "Vee" engine configuration, it is recommended to combine the manifolds upstream of the sampling probe. If this is not practical, it is permissible to acquire a sample from the group with the highest CO₂ emission. For exhaust emission calculation the total exhaust mass flow shall be used.

If the engine is equipped with an exhaust after-treatment system, the exhaust sample shall be taken downstream of the exhaust after-treatment system.

8.3.2.3. Data evaluation

For the evaluation of the gaseous emissions, the raw emission concentrations (HC, CO and NO_x) and the exhaust gas mass flow rate shall be recorded and stored with at least 2 Hz on a computer system. All other data shall be recorded with a sample rate of at least 1 Hz. For analogue analyzers, the response shall be recorded, and the calibration data may be applied online or offline during the data evaluation.

For calculation of the mass emission of the gaseous components, the traces of the recorded concentrations and the trace of the exhaust gas mass flow rate shall be time aligned by the transformation time as defined in paragraph 3.1.28. Therefore, the response time of each gaseous emissions analyzer and of the exhaust gas mass flow

system shall be determined according to paragraphs 8.3.1.2. and 9.3.5., respectively, and recorded.

8.3.2.4. Calculation of mass emission based on tabulated values

The mass of the pollutants (g/test) shall be determined by calculating the instantaneous mass emissions from the raw concentrations of the pollutants and the exhaust gas mass flow, aligned for the transformation time as determined in accordance with paragraph 8.3.2.3., integrating the instantaneous values over the cycle, and multiplying the integrated values with the u values from table 4. If measured on a dry basis, the dry/wet correction according to paragraph 8.1. shall be applied to the instantaneous concentration values before any further calculation is done.

For the calculation of NO_x , the mass emissions shall be multiplied with the humidity correction factor $k_{h,D}$, or $k_{h,G}$, as determined according to paragraph 8.2.

An example of the calculation procedures is given in annex 6.

The following equation shall be applied:

$$m_{\text{gas}} = u_{\text{gas}} \times \sum_{i=1}^{i=n} c_{\text{gas},i} \times q_{m_{\text{ew}},i} \times \frac{1}{f} \quad (\text{in g/test}) \quad (25)$$

where:

u_{gas} is the ratio between density of exhaust component and density of exhaust gas

$c_{\text{gas},i}$ is the instantaneous concentration of the component in the exhaust gas, ppm

$q_{m_{\text{ew}},i}$ is the instantaneous exhaust mass flow, kg/s

f is the data sampling rate, Hz

n is the number of measurements

Fuel	r_e	Gas					
		NO _x	CO	HC	CO ₂	O ₂	CH ₄
		r_{gas} [kg/m ³]					
		2.053	1.250	^{a)}	1.9636	1.4277	0.716
		u_{gas} ^{b)}					
Diesel	1.2943	0.001586	0.000966	0.000479	0.001517	0.001103	0.000553
Ethanol	1.2757	0.001609	0.000980	0.000805	0.001539	0.001119	0.000561
CNG ^{c)}	1.2661	0.001621	0.000987	0.000558 ^{d)}	0.001551	0.001128	0.000565
Propane	1.2805	0.001603	0.000976	0.000512	0.001533	0.001115	0.000559
Butane	1.2832	0.001600	0.000974	0.000505	0.001530	0.001113	0.000558
LPG ^{e)}	1.2811	0.001602	0.000976	0.000510	0.001533	0.001115	0.000559

a) depending on fuel

b) at $I = 2$, wet air, 273 K, 101.3 kPa

c) u accurate within 0.2 % for mass composition of: C = 66 - 76 %; H = 22 - 25 %; N = 0 - 12 %

d) NMHC on the basis of CH_{2.93} (for total HC the u_{gas} coefficient of CH₄ shall be used)

e) u accurate within 0.2 % for mass composition of: C3 = 70 - 90 %; C4 = 10 - 30 %

Table 4:

Raw exhaust gas u values and component densities

8.3.2.5. Calculation of mass emission based on exact equations

The mass of the pollutants (g/test) shall be determined by calculating the instantaneous mass emissions from the raw concentrations of the pollutants, the u values and the exhaust gas mass flow, aligned for the transformation time as determined in accordance with paragraph 8.3.2.3. and integrating the instantaneous values over the cycle. If measured on a dry basis, the dry/wet correction according to paragraph 8.1. shall be applied to the instantaneous concentration values before any further calculation is done.

For the calculation of NO_x , the mass emission shall be multiplied with the humidity correction factor $k_{h,D}$, or $k_{h,G}$, as determined according to paragraph 8.2.

The following equation shall be applied:

$$m_{\text{gas}} = \sum_{i=1}^{i=n} u_{\text{gas},i} \times c_{\text{gas},i} \times q_{mew,i} \times \frac{1}{f} \quad (\text{in g/test}) \quad (26)$$

where:

- $u_{\text{gas},i}$ is the instantaneous density ratio of exhaust component and exhaust gas
- $c_{\text{gas},i}$ is the instantaneous concentration of the component in the exhaust gas, ppm
- $q_{mew,i}$ is the instantaneous exhaust mass flow, kg/s
- f is the data sampling rate, Hz
- n is the number of measurements

The instantaneous u values shall be calculated as follows:

$$u_{\text{gas},i} = M_{\text{gas}} / (M_{e,i} \times 1,000) \quad (27)$$

or

$$u_{\text{gas},i} = r_{\text{gas}} / (r_{e,i} \times 1,000) \quad (28)$$

with

$$r_{\text{gas}} = M_{\text{gas}} / 22.414 \quad (29)$$

where:

- M_{gas} is the molar mass of the gas component, g/mol (cf. annex 6)
- $M_{e,i}$ is the instantaneous molar mass of the exhaust gas, g/mol
- r_{gas} is the density of the gas component, kg/m³
- $r_{e,i}$ is the instantaneous density of the exhaust gas, kg/m³

The molar mass of the exhaust, M_e , shall be derived for a general fuel composition $\text{C}_b\text{H}_a\text{O}_e\text{N}_d\text{S}_g$ under the assumption of complete combustion, as follows:

$$M_{e,i} = \frac{1 + \frac{q_{m_{f,i}}}{q_{m_{aw,i}}}}{\frac{q_{m_{f,i}}}{q_{m_{aw,i}}} \times \frac{\frac{a}{4} + \frac{e}{2} + \frac{d}{2}}{12.011 \times b + 1.00794 \times a + 15.9994 \times e + 14.0067 \times d + 32.065 \times g} + \frac{\frac{H_a \times 10^{-3}}{2 \times 1.00794 + 15.9994} + \frac{1}{M_a}}{1 + H_a \times 10^{-3}}} \quad (30)$$

where:

$q_{m_{aw,i}}$ is the instantaneous intake air mass flow rate on wet basis, kg/s

$q_{m_{f,i}}$ is the instantaneous fuel mass flow rate, kg/s

H_a is the intake air humidity, g water per kg dry air

M_a is the molar mass of the dry intake air = 28.965 g/mol

The exhaust density r_e shall be derived, as follows:

$$r_{e,i} = \frac{1,000 + H_a + 1,000 \times (q_{m_{f,i}}/q_{m_{ad,i}})}{773.4 + 1.2434 \times H_a + k_f \times 1,000 \times (q_{m_{f,i}}/q_{m_{ad,i}})} \quad (31)$$

where:

$q_{m_{ad,i}}$ is the instantaneous intake air mass flow rate on dry basis, kg/s

$q_{m_{f,i}}$ is the instantaneous fuel mass flow rate, kg/s

H_a is the intake air humidity, g water per kg dry air

k_f is the fuel specific factor according to equation 11 in paragraph 8.1.1.

8.3.3. Particulate determination

8.3.3.1. Introduction

The determination of the particulates requires dilution of the sample with filtered ambient air, synthetic air or nitrogen. The partial flow dilution system shall be set to completely eliminate water condensation in the dilution and sampling systems, and maintain the temperature of the diluted exhaust gas between 315 K (42 °C) and 325 K (52 °C) immediately upstream of the filter holders. Dehumidifying the dilution air before entering the dilution system is permitted, and especially useful if dilution air humidity is high. The temperature of the dilution air shall be higher than 288 K (15 °C) in close proximity to the entrance into the dilution tunnel.

The partial flow dilution system has to be designed to extract a proportional raw exhaust sample from the engine exhaust stream, thus responding to excursions in the exhaust stream flow rate, and introduce dilution air to this sample to achieve a temperature between 315 K (42 °C) and 325 K (52 °C) at the test filter. For this it is essential that the dilution ratio or the sampling ratio r_d or r_s be determined such that the accuracy requirements of paragraph 9.4.4. are fulfilled.

To determine the mass of the particulates, a particulate sampling system, particulate sampling filters, a microgram balance, and a temperature and humidity controlled

weighing chamber, are required. The details of the system are described in paragraph 9.4.

8.3.3.2. Particulate sampling

In general, the particulate sampling probe shall be installed in close proximity to the gaseous emissions sampling probe, but sufficiently distant as to not cause interference. Therefore, the installation provisions of paragraph 8.3.2.2. also apply to particulate sampling. The sampling line shall conform to the requirements laid down in annex 3.

In the case of a multi-cylinder engine with a branched exhaust manifold, the inlet of the probe shall be located sufficiently far downstream so as to ensure that the sample is representative of the average exhaust emissions from all cylinders. In multi-cylinder engines having distinct groups of manifolds, such as in a "Vee" engine configuration, it is recommended to combine the manifolds upstream of the sampling probe. If this is not practical, it is permissible to acquire a sample from the group with the highest particulate emission. For exhaust emission calculation the total exhaust mass flow shall be used.

8.3.3.3. System response time

For the control of a partial flow dilution system, a fast system response is required. The transformation time for the system shall be determined by the procedure in paragraph 9.4.6.3. If the combined transformation time of the exhaust flow measurement (see paragraph 8.3.1.2.) and the partial flow system is less than 0.3 s, online control may be used. If the transformation time exceeds 0.3 s, look ahead control based on a pre-recorded test run shall be used. In this case, the rise time shall be ≤ 1 s and the delay time of the combination ≤ 10 s.

The total system response shall be designed as to ensure a representative sample of the particulates, $q_{m_{p,i}}$, proportional to the exhaust mass flow. To determine the proportionality, a regression analysis of $q_{m_{p,i}}$ versus $q_{m_{ew,i}}$ shall be conducted on a minimum 5 Hz data acquisition rate, and the following criteria shall be met:

- (a) The coefficient of determination r^2 of the linear regression between $q_{m_{p,i}}$ and $q_{m_{ew,i}}$ shall not be less than 0.95
- (b) The standard error of estimate of $q_{m_{p,i}}$ on $q_{m_{ew,i}}$ shall not exceed 5 per cent of q_{m_p} maximum.
- (c) q_{m_p} intercept of the regression line shall not exceed ± 2 per cent of q_{m_p} maximum.

Optionally, a pre-test may be run, and the exhaust mass flow signal of the pre-test be used for controlling the sample flow into the particulate system ("look-ahead control"). Such a procedure is required if the transformation time of the particulate system, $t_{50,P}$ or/and the transformation time of the exhaust mass flow signal, $t_{50,F}$ are > 0.3 s. A correct control of the partial dilution system is obtained, if the time trace of $q_{m_{ew,pre}}$ of the pre-test, which controls q_{m_p} , is shifted by a "look-ahead" time of $t_{50,P} + t_{50,F}$.

For establishing the correlation between $q_{mp,i}$ and $q_{m_{ew},i}$ the data taken during the actual test shall be used, with $q_{m_{ew},i}$ time aligned by $t_{50,F}$ relative to $q_{mp,i}$ (no contribution from $t_{50,P}$ to the time alignment). That is, the time shift between $q_{m_{ew}}$ and q_{mp} is the difference in their transformation times that were determined in paragraph 9.4.6.3.

8.3.3.4. Data evaluation

The tare weight of the filter, as determined according to paragraph 7.8.2.2., shall be subtracted from the gross weight of the filter, as determined according to paragraph 7.8.4.5., which results in the particulate sample mass m_f . For the evaluation of the particulate concentration, the total sample mass (m_{sep}) through the filters over the test cycle shall be recorded.

With the prior approval of the type approval or certification authority, the particulate mass may be corrected for the particulate level of the dilution air, as determined in paragraph 7.8.2.5., in line with good engineering practice and the specific design features of the particulate measurement system used.

8.3.3.5. Calculation of mass emission

Depending on system design, the mass of particulates (g/test) shall be calculated by either of the methods in paragraphs 8.3.3.5.1. or 8.3.3.5.2 after buoyancy correction of the particulate sample mass according to paragraph 9.4.3.5. An example of the calculation procedures is given in annex 6.

8.3.3.5.1. Calculation based on sample ratio

$$m_{PM} = m_f / (r_s \times 1,000) \quad (32)$$

where:

m_f is the particulate mass sampled over the cycle, mg

r_s is the average sample ratio over the test cycle

with

$$r_s = \frac{m_{se}}{m_{ew}} \times \frac{m_{sep}}{m_{sed}} \quad (33)$$

where:

m_{se} is the sample mass over the cycle, kg

m_{ew} is the total exhaust mass flow over the cycle, kg

m_{sep} is the mass of diluted exhaust gas passing the particulate collection filters, kg

m_{sed} is the mass of diluted exhaust gas passing the dilution tunnel, kg

In case of the total sampling type system, m_{sep} and m_{sed} are identical

8.3.3.5.2. Calculation based on dilution ratio

$$m_{\text{PM}} = \frac{m_f}{m_{\text{sep}}} \times \frac{m_{\text{edf}}}{1,000} \quad (34)$$

where:

m_f is the particulate mass sampled over the cycle, mg

m_{sep} is the mass of diluted exhaust gas passing the particulate collection filters, kg

m_{edf} is the mass of equivalent diluted exhaust gas over the cycle, kg

The total mass of equivalent diluted exhaust gas mass over the cycle shall be determined as follows:

$$m_{\text{edf}} = \sum_{i=1}^{i=n} q_{\text{medf},i} \times \frac{1}{f} \quad (35)$$

$$q_{\text{medf},i} = q_{\text{mew},i} \times r_{\text{d},i} \quad (36)$$

$$r_{\text{d},i} = \frac{q_{\text{mdew},i}}{(q_{\text{mdew},i} - q_{\text{mdw},i})} \quad (37)$$

where:

$q_{\text{medf},i}$ is the instantaneous equivalent diluted exhaust mass flow rate, kg/s

$q_{\text{mew},i}$ is the instantaneous exhaust mass flow rate, kg/s

$r_{\text{d},i}$ is the instantaneous dilution ratio

$q_{\text{mdew},i}$ is the instantaneous diluted exhaust mass flow rate, kg/s

$q_{\text{mdw},i}$ is the instantaneous dilution air mass flow rate, kg/s

f is the data sampling rate, Hz

n is the number of measurements

8.4. Full flow dilution measurement (CVS)

The concentration signals, either by integration over the cycle or by bag sampling, of the gaseous components shall be used for the calculation of the mass emissions by multiplication with the diluted exhaust mass flow rate. The exhaust mass flow rate shall be measured with a constant volume sampling (CVS) system, which may use a positive displacement pump (PDP), a critical flow venturi (CFV) or a subsonic venturi (SSV).

For particulates, a proportional sample shall be taken from the diluted exhaust gas of the CVS system.

The complete test set up is schematically shown in figure 7.

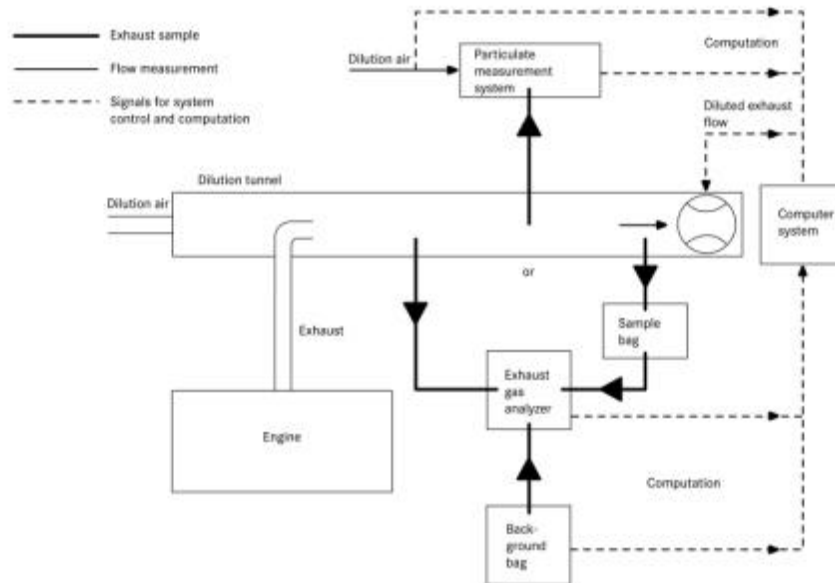

Figure 7:
Scheme of full flow measurement system

8.4.1. Determination of the diluted exhaust gas flow

8.4.1.1. Introduction

For calculation of the emissions in the diluted exhaust gas, it is necessary to know the diluted exhaust gas mass flow rate. The total diluted exhaust gas flow over the cycle (kg/test) shall be calculated from the measurement values over the cycle and the corresponding calibration data of the flow measurement device (V_0 for PDP, K_V for CFV, C_d for SSV) by either of the methods described in paragraphs 8.4.1.2. to 8.4.1.4. may be used. If the total sample mass of particulates (m_{sep}) and gaseous pollutants exceeds 0.5 per cent of the total CVS flow (m_{ed}), the CVS flow shall be corrected for m_{sep} or the particulate sample flow shall be returned to the CVS prior to the flow measuring device.

8.4.1.2. PDP-CVS system

The calculation of the mass flow over the cycle is as follows, if the temperature of the diluted exhaust is kept within ± 6 K over the cycle by using a heat exchanger:

$$m_{ed} = 1.293 \times V_0 \times n_p \times p_p \times 273 / (101.3 \times T) \quad (38)$$

where:

- V_0 is the volume of gas pumped per revolution under test conditions, m³/rev
- n_p is the total revolutions of pump per test
- p_p is the absolute pressure at pump inlet, kPa
- T is the average temperature of the diluted exhaust gas at pump inlet, K

If a system with flow compensation is used (i.e. without heat exchanger), the instantaneous mass emissions shall be calculated and integrated over the cycle. In this case, the instantaneous mass of the diluted exhaust gas shall be calculated as follows:

$$m_{ed,i} = 1.293 \times V_0 \times n_{p,i} \times p_p \times 273 / (101.3 \times T) \quad (39)$$

where:

- $n_{p,i}$ is the total revolutions of pump per time interval

8.4.1.3. CFV-CVS system

The calculation of the mass flow over the cycle is as follows, if the temperature of the diluted exhaust is kept within ± 11 K over the cycle by using a heat exchanger:

$$m_{ed} = 1.293 \times t \times K_v \times p_p / T^{0.5} \quad (40)$$

where:

- t is the cycle time, s
- K_v is the calibration coefficient of the critical flow venturi for standard conditions,
- p_p is the absolute pressure at venturi inlet, kPa
- T is the absolute temperature at venturi inlet, K

If a system with flow compensation is used (i.e. without heat exchanger), the instantaneous mass emissions shall be calculated and integrated over the cycle. In this case, the instantaneous mass of the diluted exhaust gas shall be calculated as follows:

$$m_{ed,i} = 1.293 \times \Delta t_i \times K_v \times p_p / T^{0.5} \quad (41)$$

where:

- Δt_i is the time interval, s

8.4.1.4. SSV-CVS system

The calculation of the mass flow over the cycle shall be as follows, if the temperature of the diluted exhaust is kept within ± 11 K over the cycle by using a heat exchanger:

$$m_{ed} = 1.293 \times Q_{SSV} \quad (42)$$

with

$$Q_{SSV} = A_0 d_v^2 C_d p_p \sqrt{\left[\frac{1}{T} (r_p^{1.4286} - r_p^{1.7143}) \cdot \left(\frac{1}{1 - r_D^4 r_p^{1.4286}} \right) \right]} \quad (43)$$

where:

$$A_0 \text{ is } 0.006111 \text{ in SI units of } \left(\frac{m^3}{\text{min}} \right) \left(\frac{K^{\frac{1}{2}}}{kPa} \right) \left(\frac{1}{mm^2} \right)$$

d_v is the diameter of the SSV throat, m

C_d is the discharge coefficient of the SSV

p_p is the absolute pressure at venturi inlet, kPa

T is the temperature at the venturi inlet, K

r_p is the ratio of the SSV throat to inlet absolute static pressure, $1 - \frac{\Delta p}{P_a}$

r_D is the ratio of the SSV throat diameter, d , to the inlet pipe inner diameter D

If a system with flow compensation is used (i.e. without heat exchanger), the instantaneous mass emissions shall be calculated and integrated over the cycle. In this case, the instantaneous mass of the diluted exhaust gas shall be calculated as follows:

$$m_{ed} = 1.293 \times Q_{SSV} \times \Delta t_i \quad (44)$$

where:

Δt_i is the time interval, s

The real time calculation shall be initialized with either a reasonable value for C_d , such as 0.98, or a reasonable value of Q_{SSV} . If the calculation is initialized with Q_{SSV} , the initial value of Q_{SSV} shall be used to evaluate the Reynolds number.

During all emissions tests, the Reynolds number at the SSV throat shall be in the range of Reynolds numbers used to derive the calibration curve developed in paragraph 9.5.4.

8.4.2. Determination of the gaseous components

8.4.2.1. Introduction

The gaseous components in the diluted exhaust gas emitted by the engine submitted for testing shall be measured by the methods described in annex 3. Dilution of the exhaust shall be done with filtered ambient air, synthetic air or nitrogen. The flow capacity of the full flow system shall be large enough to completely eliminate water condensation in the dilution and sampling systems. Data evaluation and calculation procedures are described in paragraphs 8.4.2.3. and 8.4.2.4.

8.4.2.2. Sampling for gaseous emissions

The exhaust pipe between the engine and the full flow dilution system shall conform to the requirements laid down in annex 3. The gaseous emissions sample probe(s) shall be installed in the dilution tunnel at a point where the dilution air and exhaust gas are well mixed, and in close proximity to the particulates sampling probe.

Sampling can generally be done in two ways:

- (a) the pollutants are sampled into a sampling bag over the cycle and measured after completion of the test; for HC, the sample bag shall be heated to 464 ± 11 K ($191 \pm 11^\circ\text{C}$), for NO_x , the sample bag temperature shall be above the dew point temperature;
- (b) the pollutants are sampled continuously and integrated over the cycle.

The background concentrations shall be sampled upstream of the dilution tunnel into a sampling bag, and shall be subtracted from the emissions concentration according to paragraph 8.4.2.4.2.

8.4.2.3. Data evaluation

For the evaluation of the gaseous emissions, the emission concentrations (HC, CO and NO_x) and the diluted exhaust gas mass flow rate shall be recorded and stored with at least 1 Hz on a computer system. All other data shall be recorded with a sample rate of at least 1 Hz. For analog analyzers the response will be recorded, and the calibration data may be applied online or offline during the data evaluation.

8.4.2.4. Calculation of mass emission

8.4.2.4.1. Systems with constant mass flow

For systems with heat exchanger, the mass of the pollutants shall be determined from the following equation:

$$m_{\text{gas}} = u_{\text{gas}} \times c_{\text{gas}} \times m_{\text{ed}} \quad (\text{in g/test}) \quad (45)$$

where:

u_{gas} is the ratio between density of exhaust component and density of air

c_{gas} is the average background corrected concentration of the component, ppm

m_{ed} is the total diluted exhaust mass over the cycle, kg

$q_{m_{\text{dew}}}$ is the diluted exhaust gas mass flow rate, kg/s

If measured on a dry basis, the dry/wet correction according to paragraph 8.1. shall be applied.

For the calculation of NO_x , the mass emission shall be multiplied with the humidity correction factor $k_{h,D}$, or $k_{h,G}$, as determined according to paragraph 8.2.

The u values are given in table 5. For calculating the u_{gas} values, the density of the diluted exhaust gas has been assumed to be equal to air density. Therefore, the u_{gas} values are identical for single gas components, but different for HC.

Alternatively, the exact equation method described in paragraph 8.3.2.5., equations 27 or 28 may be used.

Fuel	r_{de}	Gas					
		NO_x	CO	HC	CO_2	O_2	CH_4
		r_{gas} [kg/m^3]					
		2.053	1.250	^{a)}	1.9636	1.4277	0.716
u_{gas} ^{b)}							
Diesel	1.293	0.001588	0.000967	0.000480	0.001519	0.001104	0.000553
Ethanol	1.293	0.001588	0.000967	0.000795	0.001519	0.001104	0.000553
CNG ^{c)}	1.293	0.001588	0.000967	0.000584 ^{d)}	0.001519	0.001104	0.000553
Propane	1.293	0.001588	0.000967	0.000507	0.001519	0.001104	0.000553
Butane	1.293	0.001588	0.000967	0.000501	0.001519	0.001104	0.000553
LPG ^{e)}	1.293	0.001588	0.000967	0.000505	0.001519	0.001104	0.000553
a) depending on fuel b) at $I = 2$, wet air, 273 K, 101.3 kPa c) u accurate within 0.2 % for mass composition of: C = 66 - 76 %; H = 22 - 25 %; N = 0 - 12 % d) NMHC on the basis of $\text{CH}_{2.93}$ (for total HC the u_{gas} coefficient of CH_4 shall be used) e) u accurate within 0.2 % for mass composition of: C3 = 70 - 90 %; C4 = 10 - 30 %							

Table 5:
Diluted exhaust gas u values and component densities

8.4.2.4.2. Determination of the background corrected concentrations

The average background concentration of the gaseous pollutants in the dilution air shall be subtracted from measured concentrations to get the net concentrations of the pollutants. The average values of the background concentrations can be determined by the sample bag method or by continuous measurement with integration. The following equation shall be used:

$$c = c_e - c_d \times (1 - (1/D)) \quad (46)$$

where:

c_e is the concentration of the component measured in the diluted exhaust gas, ppm

c_d is the concentration of the component measured in the dilution air, ppm

D is the dilution factor

The dilution factor shall be calculated as follows:

a) for diesel and LPG fueled gas engines

$$D = \frac{F_S}{c_{\text{CO}_2,e} + (c_{\text{HC},e} + c_{\text{CO},e}) \times 10^{-4}} \quad (47)$$

b) for NG fueled gas engines

$$D = \frac{F_S}{c_{\text{CO}_2,e} + (c_{\text{NMHC},e} + c_{\text{CO},e}) \times 10^{-4}} \quad (48)$$

where:

$c_{\text{CO}_2,e}$ is the wet concentration of CO_2 in the diluted exhaust gas, per cent vol

$c_{\text{HC},e}$ is the wet concentration of HC in the diluted exhaust gas, ppm C1

$c_{\text{NMHC},e}$ is the wet concentration of NMHC in the diluted exhaust gas, ppm C1

$c_{\text{CO},e}$ is the wet concentration of CO in the diluted exhaust gas, ppm

F_S is the stoichiometric factor

The stoichiometric factor shall be calculated as follows:

$$F_S = 100 \times \frac{1}{1 + \frac{a}{2} + 3.76 \times \left(1 + \frac{a}{4}\right)} \quad (49)$$

where:

a is the molar hydrogen ratio of the fuel (H/C)

Alternatively, if the fuel composition is not known, the following stoichiometric factors may be used:

$$F_S (\text{diesel}) = 13.4$$

$$F_S (\text{LPG}) = 11.6$$

$$F_S (\text{NG}) = 9.5$$

8.4.2.4.3 Systems with Flow Compensation

For systems without heat exchanger, the mass of the pollutants (g/test) shall be determined by calculating the instantaneous mass emissions and integrating the instantaneous values over the cycle. Also, the background correction shall be applied directly to the instantaneous concentration value. The following equation shall be applied:

$$m_{\text{gas}} = \sum_{i=1}^n [(m_{\text{ed},i} \times c_e \times u_{\text{gas}})] - [(m_{\text{ed}} \times c_d \times (1 - 1/D) \times u_{\text{gas}})] \quad (50)$$

where:

c_e is the concentration of the component measured in the diluted exhaust gas, ppm

c_d is the concentration of the component measured in the dilution air, ppm

$m_{ed,i}$ is the instantaneous mass of the diluted exhaust gas, kg

m_{ed} is the total mass of diluted exhaust gas over the cycle, kg

u_{gas} is the tabulated value from table 5

D is the dilution factor

8.4.3. Particulate determination

8.4.3.1. Introduction

The determination of the particulates requires dilution of the sample with filtered ambient air, synthetic air or nitrogen. The flow capacity of the full flow double dilution system shall be large enough to completely eliminate water condensation in the dilution and sampling systems, and maintain the temperature of the diluted exhaust gas between 315 K (42 °C) and 325 K (52 °C) immediately upstream of the filter holders. Dehumidifying the dilution air before entering the dilution system is permitted, and especially useful if dilution air humidity is high. The temperature of the dilution air shall be higher than 288 K (15 °C) in close proximity to the entrance into the dilution tunnel.

To determine the mass of the particulates, a particulate sampling system, particulate sampling filters, a microgram balance, and a temperature and humidity controlled weighing chamber, are required. The details of the system are described in paragraph 9.4.

8.4.3.2. Particulate sampling

The particulate sampling probe shall be installed in close proximity to the gaseous emissions sampling probe, but sufficiently distant as to not cause interference, in the dilution tunnel. Therefore, the installation provisions of paragraph 8.3.2.2. also apply to particulate sampling. The sampling line shall conform to the requirements laid down in annex 3.

8.4.3.3. Calculation of mass emission

The particulate mass (g/test) shall be calculated after buoyancy correction of the particulate sample mass according to paragraph 9.4.3.5. as follows:

$$m_{PM} = \frac{m_f}{m_{sep}} \times \frac{m_{ed}}{1,000} \quad (51)$$

where:

- m_f is the particulate mass sampled over the cycle, mg
 m_{sep} is the mass of diluted exhaust gas passing the particulate collection filters, kg
 m_{ed} is the mass of diluted exhaust gas over the cycle, kg

with

$$m_{sep} = m_{set} - m_{ssd} \quad (52)$$

where:

- m_{set} is the mass of double diluted exhaust gas through particulate filter, kg
 m_{ssd} is the mass of secondary dilution air, kg

If the particulate background level of the dilution air is determined in accordance with paragraph 7.8.2.5, the particulate mass may be background corrected. In this case, the particulate mass (g/test) shall be calculated as follows:

$$m_{PM} = \left[\frac{m_f}{m_{sep}} - \left(\frac{m_b}{m_{sd}} \times \left(1 - \frac{1}{D} \right) \right) \right] \times \frac{m_{ed}}{1,000} \quad (53)$$

where:

- m_{sep} is the mass of diluted exhaust gas passing the particulate collection filters, kg
 m_{ed} is the mass of diluted exhaust gas over the cycle, kg
 m_{sd} is the mass of dilution air sampled by background particulate sampler, kg
 m_b is the mass of the collected background particulates of the dilution air, mg
 D is the dilution factor as determined in paragraph 8.4.2.4.2.

8.5. General calculations

8.5.1. Calculation of NMHC and CH₄ with the non-methane cutter

The concentration of NMHC and CH₄ shall be calculated as follows:

$$c_{NMHC} = \frac{c_{HC(w/oCutter)} \times (1 - E_M) - c_{HC(w/Cutter)}}{E_E - E_M} \quad (54)$$

$$c_{CH4} = \frac{c_{HC(w/Cutter)} - c_{HC(w/oCutter)} \times (1 - E_E)}{E_E - E_M} \quad (55)$$

where:

- $c_{HC(w/Cutter)}$ is the HC concentration with sample gas flowing through the NMC, ppm
 $c_{HC(w/oCutter)}$ is the HC concentration with sample gas bypassing the NMC, ppm
 E_M is the methane efficiency as determined per paragraph 9.3.8.1.
 E_E is the ethane efficiency as determined per paragraph 9.3.8.2.

8.5.2. Calculation of the specific emissions

The specific emissions e_{gas} or e_{PM} (g/kWh) shall be calculated for each individual component in the following ways depending on the type of test cycle.

8.5.2.1. Hot start test (WHSC and hot WHTC)

$$e = \frac{m}{W_{\text{act}}} \quad (56)$$

where:

m is the mass emission of the component, g/test

W_{act} is the actual cycle work as determined according to paragraph 7.7.1., kWh

The final test result of the WHTC shall be a weighted average from cold start test and hot start test by using either of the following options:

$$e = \frac{(0.14 \times m_{\text{cold}}) + (0.86 \times m_{\text{hot}})}{(0.14 \times W_{\text{act,cold}}) + (0.86 \times W_{\text{act,hot}})} \quad (57a)$$

$$e = \frac{(0.1 \times m_{\text{cold}}) + (0.9 \times m_{\text{hot}})}{(0.1 \times W_{\text{act,cold}}) + (0.9 \times W_{\text{act,hot}})} \quad (57b)$$

The option shall be selected by the Contracting Parties.

8.5.2.3. Periodic exhaust after-treatment systems

The hot start emissions shall be weighted as follows:

$$e_w = \frac{n \times \bar{e} + n_r \times \bar{e}_r}{n + n_r} \quad (58)$$

where:

n is the number of WHTC hot start tests outside regenerations

n_r is the number of WHTC hot start tests during regeneration (minimum one test)

e is the average specific emission outside regeneration, g/kWh

e_r is the average specific emission during regeneration, g/kWh

The regeneration factor k_r shall be determined as follows:

$$k_r = \frac{e_w}{e} \quad (59)$$

The regeneration factor k_r :

- (a) shall be applied to the weighted WHTC test result of paragraph 8.5.2.2.,
- (b) may be applied to the WHSC and cold WHTC, if a regeneration occurs during the cycle
- (c) may be extended to other members of the same engine family,
- (d) may be extended to other engine families using the same aftertreatment system with the prior approval of the type approval or certification authority based on technical evidence to be supplied by the manufacturer that the emissions are similar.

9. MEASUREMENT EQUIPMENT

This gtr does not contain details of flow, pressure, and temperature measuring equipment or systems. Instead, only the linearity requirements of such equipment or systems necessary for conducting an emissions test are given in paragraph 9.2.

9.1. Dynamometer specification

An engine dynamometer with adequate characteristics to perform the appropriate test cycle described in paragraphs 7.2 and 7.3 shall be used.

The instrumentation for torque and speed measurement shall allow the measurement accuracy of the shaft power as needed to comply with the cycle validation criteria. Additional calculations may be necessary. The accuracy of the measuring equipment shall be such that the linearity requirements given in paragraph 9.2, table 6 are not exceeded.

9.2. Linearity requirements

The calibration of all measuring instruments and systems shall be traceable to national (international) standards. The measuring instruments and systems shall comply with the linearity requirements given in table 6. The linearity verification according to paragraph 9.2.1. shall be performed for the gas analyzers at least every 3 months or whenever a system repair or change is made that could influence calibration. For the other instruments and systems, the linearity verification shall be done as required by internal audit procedures, by the instrument manufacturer or in accordance with ISO 9000 requirements.

Measurement system	Intercept b	Slope m	Standard error SEE	Coefficient of determination r^2
Engine speed	= 0.05 % max	0.98 - 1.02	= 2 % max	= 0.990
Engine torque	= 1 % max	0.98 - 1.02	= 2 % max	= 0.990
Fuel flow	= 1 % max	0.98 - 1.02	= 2 % max	= 0.990
Airflow	= 1 % max	0.98 - 1.02	= 2 % max	= 0.990
Exhaust gas flow	= 1 % max	0.98 - 1.02	= 2 % max	= 0.990
Dilution airflow	= 1 % max	0.98 - 1.02	= 2 % max	= 0.990
Diluted exhaust gas flow	= 1 % max	0.98 - 1.02	= 2 % max	= 0.990
Sample flow	= 1 % max	0.98 - 1.02	= 2 % max	= 0.990
Gas analyzers	= 0.5 % max	0.99 - 1.01	= 1 % max	= 0.998
Gas dividers	= 0.5 % max	0.98 - 1.02	= 2 % max	= 0.990
Temperatures	= 1 % max	0.99 - 1.01	= 1 % max	= 0.998
Pressures	= 1 % max	0.99 - 1.01	= 1 % max	= 0.998
PM balance	= 1 % max	0.99 - 1.01	= 1 % max	= 0.998

Table 6:
Linearity requirements of instruments and measurement systems

9.2.1. Linearity verification

9.2.1.1. Introduction

A linearity verification shall be performed for each measurement system listed in table 6. At least 10 reference values shall be introduced to the measurement system, and the measured values shall be compared to the reference values by using a least squares linear regression. The maximum limits in table 6 refer to the maximum values expected during testing.

9.2.1.2. General requirements

The measurement systems shall be warmed up according to the recommendations of the instrument manufacturer. The measurement systems shall be operated at their specified temperatures, pressures and flows.

9.2.1.3. Procedure

The linearity verification shall be run for each normally used operating range with the following steps.

- (a) The instrument shall be set at zero by introducing a zero signal. For gas analyzers, purified synthetic air (or nitrogen) shall be introduced directly to the analyzer port.

- (b) The instrument shall be spanned by introducing a span signal. For gas analyzers, an appropriate span gas shall be introduced directly to the analyzer port.
- (c) The zero procedure of (a) shall be repeated.
- (d) The verification shall be established by introducing at least 10 reference values (including zero) that are within the range from zero to the highest values expected during emission testing. For gas analyzers, known gas concentrations shall be introduced directly to the analyzer port.
- (e) At a recording frequency of at least 1 Hz, the reference values shall be measured and the measured values recorded for 30 s.
- (f) The arithmetic mean values over the 30 s period shall be used to calculate the least squares linear regression parameters according to equation 6 in paragraph 7.7.2.
- (g) The linear regression parameters shall meet the requirements of paragraph 9.2., table 6.
- (h) The zero setting shall be rechecked and the verification procedure repeated, if necessary.

9.3. Gaseous emissions measurement and sampling system

9.3.1. Analyzer specifications

9.3.1.1. General

The analyzers shall have a measuring range and response time appropriate for the accuracy required to measure the concentrations of the exhaust gas components under transient and steady state conditions.

The electromagnetic compatibility (EMC) of the equipment shall be on a level as to minimize additional errors.

9.3.1.2. Accuracy

Accuracy is defined as the deviation of the analyzer reading from the reference value. The accuracy shall not exceed ± 2 per cent of the reading or ± 0.3 per cent of full scale whichever is larger.

9.3.1.3. Precision

The precision, defined as 2.5 times the standard deviation of 10 repetitive responses to a given calibration or span gas, shall be no greater than 1 per cent of full scale concentration for each range used above 155 ppm (or ppm C) or 2 per cent of each range used below 155 ppm (or ppm C).

9.3.1.4. Noise

The analyzer peak-to-peak response to zero and calibration or span gases over any 10 seconds period shall not exceed 2 per cent of full scale on all ranges used.

9.3.1.5. Zero drift

Zero response is defined as the mean response, including noise, to a zero gas during a 30 s time interval. The drift of the zero response during a one-hour period shall be less than 2 per cent of full scale on the lowest range used.

9.3.1.6. Span drift

Span response is defined as the mean response, including noise, to a span gas during a 30 s time interval. The drift of the span response during a one-hour period shall be less than 2 per cent of full scale on the lowest range used.

9.3.1.7. Rise time

The rise time of the analyzer installed in the measurement system shall not exceed 2.5 s.

9.3.1.8. Gas drying

Exhaust gases may be measured wet or dry. A gas-drying device, if used, shall have a minimal effect on the composition of the measured gases. Chemical dryers are not an acceptable method of removing water from the sample.

9.3.2. Gas analyzers

9.3.2.1. Introduction

Paragraphs 9.3.2.2 to 9.3.2.7 describe the measurement principles to be used. A detailed description of the measurement systems is given in annex 3. The gases to be measured shall be analyzed with the following instruments. For non-linear analyzers, the use of linearizing circuits is permitted.

9.3.2.2. Carbon monoxide (CO) analysis

The carbon monoxide analyzer shall be of the non-dispersive infrared (NDIR) absorption type.

9.3.2.3. Carbon dioxide (CO₂) analysis

The carbon dioxide analyzer shall be of the non-dispersive infrared (NDIR) absorption type.

9.3.2.4. Hydrocarbon (HC) analysis

The hydrocarbon analyzer shall be of the heated flame ionization detector (HFID) type with detector, valves, pipework, etc. heated so as to maintain a gas temperature

of $463 \text{ K} \pm 10 \text{ K}$ ($190 \pm 10 \text{ }^\circ\text{C}$). Optionally, for NG fueled and PI engines, the hydrocarbon analyzer may be of the non-heated flame ionization detector (FID) type depending upon the method used (see annex 3, paragraph A.3.1.3.).

9.3.2.5. Non-methane hydrocarbon (NMHC) analysis

The determination of the non-methane hydrocarbon fraction shall be performed with a heated non-methane cutter (NMC) operated in line with an FID as per annex 3, paragraph A.3.1.4. by subtraction of the methane from the hydrocarbons.

9.3.2.6. Oxides of nitrogen (NO_x) analysis

If measured on a dry basis, the oxides of nitrogen analyzer shall be of the chemiluminescent detector (CLD) or heated chemiluminescent detector (HCLD) type with a NO_2/NO converter. If measured on a wet basis, a HCLD with converter maintained above 328 K ($55 \text{ }^\circ\text{C}$) shall be used, provided the water quench check (see paragraph 9.3.9.2.2.) is satisfied. For both CLD and HCLD, the sampling path shall be maintained at a wall temperature of 328 K to 473 K ($55 \text{ }^\circ\text{C}$ to $200 \text{ }^\circ\text{C}$) up to the converter for dry measurement, and up to the analyzer for wet measurement.

9.3.2.7. Air to fuel measurement

The air to fuel measurement equipment used to determine the exhaust gas flow as specified in paragraph 8.3.1.6. shall be a wide range air to fuel ratio sensor or lambda sensor of Zirconia type. The sensor shall be mounted directly on the exhaust pipe where the exhaust gas temperature is high enough to eliminate water condensation.

The accuracy of the sensor with incorporated electronics shall be within:

± 3 per cent of reading	for	$\lambda < 2$
± 5 per cent of reading	for	$2 \leq \lambda < 5$
± 10 per cent of reading	for	$5 \leq \lambda$

To fulfill the accuracy specified above, the sensor shall be calibrated as specified by the instrument manufacturer.

9.3.3. Calibration gases

The shelf life of all calibration gases shall be respected. The expiration date of the calibration gases stated by the manufacturer shall be recorded.

9.3.3.1. Pure gases

The required purity of the gases is defined by the contamination limits given below. The following gases shall be available for operation:

Purified nitrogen

(Contamination ≤ 1 ppm Cl, ≤ 1 ppm CO, ≤ 400 ppm CO₂, ≤ 0.1 ppm NO)

Purified oxygen

(Purity > 99.5 per cent vol O₂)

Hydrogen-helium mixture

(40 ± 2 per cent hydrogen, balance helium)

(Contamination ≤ 1 ppm Cl, ≤ 400 ppm CO₂)

Purified synthetic air

(Contamination ≤ 1 ppm Cl, ≤ 1 ppm CO, ≤ 400 ppm CO₂, ≤ 0.1 ppm NO)

(Oxygen content between 18-21 per cent vol.)

9.3.3.2. Calibration and span gases

Mixtures of gases having the following chemical compositions shall be available. Other gas combinations are allowed provided the gases do not react with one another.

C₃H₈ and purified synthetic air (see paragraph 9.3.3.1.);

CO and purified nitrogen;

NO_x and purified nitrogen (the amount of NO₂ contained in this calibration gas shall not exceed 5 per cent of the NO content);

CO₂ and purified nitrogen

CH₄ and purified synthetic air

C₂H₆ and purified synthetic air

The true concentration of a calibration and span gas shall be within ± 1 per cent of the nominal value, and shall be traceable to national and international standards. All concentrations of calibration gas shall be given on a volume basis (volume percent or volume ppm).

9.3.3.3. Gas dividers

The gases used for calibration and span may also be obtained by means of gas dividers (precision blending devices), diluting with purified N₂ or with purified synthetic air. The accuracy of the gas divider shall be such that the concentration of the blended calibration gases is accurate to within ± 2 per cent. This accuracy implies that primary gases used for blending shall be known to an accuracy of at least ± 1 per cent, traceable to national or international gas standards. The verification shall be performed at between 15 and 50 per cent of full scale for each calibration incorporating a gas divider. An additional verification may be performed using another calibration gas, if the first verification has failed.

Optionally, the blending device may be checked with an instrument which by nature is linear, e.g. using NO gas with a CLD. The span value of the instrument shall be adjusted with the span gas directly connected to the instrument. The gas divider shall be checked at the settings used and the nominal value shall be compared to the measured concentration of the instrument. This difference shall in each point be within ± 1 per cent of the nominal value.

For conducting the linearity verification according to paragraph 9.2.1., the gas divider shall be accurate to within ± 1 per cent.

9.3.3.4. Oxygen interference check gases

Oxygen interference check gases are a blend of propane, oxygen and nitrogen. They shall contain propane with 350 ppm C \pm 75 ppm C hydrocarbon. The concentration value shall be determined to calibration gas tolerances by chromatographic analysis of total hydrocarbons plus impurities or by dynamic blending. The oxygen concentrations required for positive ignition and compression ignition engine testing are listed in table 7 with the remainder being purified nitrogen.

Type of engine	O ₂ concentration (per cent)
Compression ignition	21 (20 to 22)
Compression and positive ignition	10 (9 to 11)
Compression and positive ignition	5 (4 to 6)
Positive ignition	0 (0 to 1)

Table 7:
Oxygen interference check gases

9.3.4. Leakage test

A system leakage test shall be performed. The probe shall be disconnected from the exhaust system and the end plugged. The analyzer pump shall be switched on. After an initial stabilization period all flowmeters shall read zero. If not, the sampling lines shall be checked and the fault corrected.

The maximum allowable leakage rate on the vacuum side shall be 0.5 per cent of the in-use flow rate for the portion of the system being checked. The analyzer flows and bypass flows may be used to estimate the in-use flow rates.

Alternatively, the system may be evacuated to a pressure of at least 20 kPa vacuum (80 kPa absolute). After an initial stabilization period the pressure increase Dp (kPa/min) in the system shall not exceed:

$$Dp = p / V_s \times 0.005 \times q_{vs} \quad (60)$$

where:

V_s is the system volume, l

q_{vs} is the system flow rate, l/min

Another method is the introduction of a concentration step change at the beginning of the sampling line by switching from zero to span gas. If for a correctly calibrated analyzer after an adequate period of time the reading is = 99 per cent compared to the introduced concentration, this points to a leakage problem that shall be corrected.

9.3.5. Response time check of the analytical system

The system settings for the response time evaluation shall be exactly the same as during measurement of the test run (i.e. pressure, flow rates, filter settings on the analyzers and all other response time influences). The response time determination shall be done with gas switching directly at the inlet of the sample probe. The gas switching shall be done in less than 0.1 s. The gases used for the test shall cause a concentration change of at least 60 per cent full scale (FS).

The concentration trace of each single gas component shall be recorded. The response time is defined to be the difference in time between the gas switching and the appropriate change of the recorded concentration. The system response time (t_{90}) consists of the delay time to the measuring detector and the rise time of the detector. The delay time is defined as the time from the change (t_0) until the response is 10 per cent of the final reading (t_{10}). The rise time is defined as the time between 10 per cent and 90 per cent response of the final reading ($t_{90} - t_{10}$).

For time alignment of the analyzer and exhaust flow signals, the transformation time is defined as the time from the change (t_0) until the response is 50 per cent of the final reading (t_{50}).

The system response time shall be ≤ 10 s with a rise time of ≤ 2.5 s in accordance with paragraph 9.3.1.7. for all limited components (CO, NO_x, HC or NMHC) and all ranges used.

9.3.6. Efficiency test of NO_x converter

The efficiency of the converter used for the conversion of NO₂ into NO is tested as given in paragraphs 9.3.6.1 to 9.3.6.8 (see figure 8).

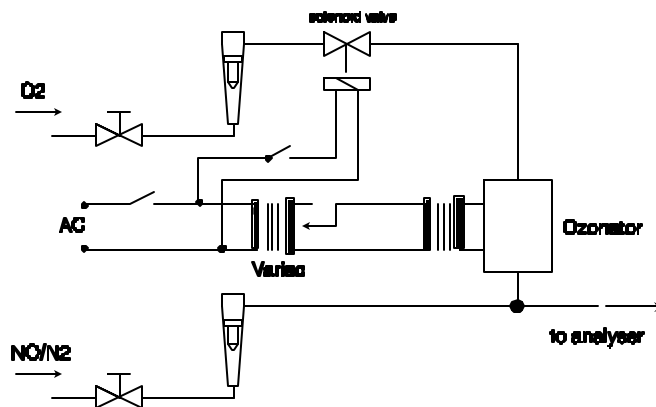

Figure 8:
Scheme of NO₂ converter efficiency device

9.3.6.1. Test setup

Using the test setup as schematically shown in figure 8 and the procedure below, the efficiency of the converter shall be tested by means of an ozonator.

9.3.6.2. Calibration

The CLD and the HCLD shall be calibrated in the most common operating range following the manufacturer's specifications using zero and span gas (the NO content of which shall amount to about 80 per cent of the operating range and the NO₂ concentration of the gas mixture to less than 5 per cent of the NO concentration). The NO_x analyzer shall be in the NO mode so that the span gas does not pass through the converter. The indicated concentration has to be recorded.

9.3.6.3. Calculation

The per cent efficiency of the converter shall be calculated as follows:

$$E_{\text{NO}_x} = \left(1 + \frac{a - b}{c - d} \right) \times 100 \quad (61)$$

where:

- a* is the NO_x concentration according to paragraph 9.3.6.6.
- b* is the NO_x concentration according to paragraph 9.3.6.7.
- c* is the NO concentration according to paragraph 9.3.6.4.
- d* is the NO concentration according to paragraph 9.3.6.5.

9.3.6.4. Adding of oxygen

Via a T-fitting, oxygen or zero air shall be added continuously to the gas flow until the concentration indicated is about 20 per cent less than the indicated calibration concentration given in paragraph 9.3.6.2. (the analyzer is in the NO mode).

The indicated concentration (*c*) shall be recorded. The ozonator is kept deactivated throughout the process.

9.3.6.5. Activation of the ozonator

The ozonator shall be activated to generate enough ozone to bring the NO concentration down to about 20 per cent (minimum 10 per cent) of the calibration concentration given in paragraph 9.3.6.2. The indicated concentration (*d*) shall be recorded (the analyzer is in the NO mode).

9.3.6.6. NO_x mode

The NO analyzer shall be switched to the NO_x mode so that the gas mixture (consisting of NO, NO₂, O₂ and N₂) now passes through the converter. The indicated concentration (*a*) shall be recorded (the analyzer is in the NO_x mode).

9.3.6.7. Deactivation of the ozonator

The ozonator is now deactivated. The mixture of gases described in paragraph 9.3.6.6. passes through the converter into the detector. The indicated concentration (*b*) shall be recorded (the analyzer is in the NO_x mode).

9.3.6.8. NO mode

Switched to NO mode with the ozonator deactivated, the flow of oxygen or synthetic air shall be shut off. The NO_x reading of the analyzer shall not deviate by more than ± 5 per cent from the value measured according to paragraph 9.3.6.2. (the analyzer is in the NO mode).

9.3.6.9. Test interval

The efficiency of the converter shall be tested at least once per month.

9.3.6.10. Efficiency requirement

The efficiency of the converter E_{NOx} shall not be less than 95 per cent.

If, with the analyzer in the most common range, the ozonator cannot give a reduction from 80 per cent to 20 per cent according to paragraph 9.3.6.5., the highest range which will give the reduction shall be used.

9.3.7. Adjustment of the FID

9.3.7.1. Optimization of the detector response

The FID shall be adjusted as specified by the instrument manufacturer. A propane in air span gas shall be used to optimize the response on the most common operating range.

With the fuel and airflow rates set at the manufacturer's recommendations, a 350 ± 75 ppm C span gas shall be introduced to the analyzer. The response at a given fuel flow shall be determined from the difference between the span gas response and the zero gas response. The fuel flow shall be incrementally adjusted above and below the manufacturer's specification. The span and zero response at these fuel flows shall be recorded. The difference between the span and zero response shall be plotted and the fuel flow adjusted to the rich side of the curve. This is the initial flow rate setting which may need further optimization depending on the results of the hydrocarbon response factors and the oxygen interference check according to paragraphs 9.3.7.2. and 9.3.7.3. If the oxygen interference or the hydrocarbon response factors do not meet the following specifications, the airflow shall be incrementally adjusted above and below the manufacturer's specifications, repeating paragraphs 9.3.7.2. and 9.3.7.3. for each flow.

The optimization may optionally be conducted using the procedures outlined in SAE paper No. 770141.

9.3.7.2. Hydrocarbon response factors

A linearity verification of the analyzer shall be performed using propane in air and purified synthetic air according to paragraph 9.2.1.3.

Response factors shall be determined when introducing an analyzer into service and after major service intervals. The response factor (r_h) for a particular hydrocarbon species is the ratio of the FID C1 reading to the gas concentration in the cylinder expressed by ppm C1.

The concentration of the test gas shall be at a level to give a response of approximately 80 per cent of full scale. The concentration shall be known to an accuracy of ± 2 per cent in reference to a gravimetric standard expressed in volume. In addition, the gas cylinder shall be preconditioned for 24 hours at a temperature of $298 \text{ K} \pm 5 \text{ K}$ ($25 \text{ }^\circ\text{C} \pm 5 \text{ }^\circ\text{C}$).

The test gases to be used and the relative response factor ranges are as follows:

- | | |
|------------------------------------------|---------------------------|
| (a) Methane and purified synthetic air | $1.00 \leq r_h \leq 1.15$ |
| (b) Propylene and purified synthetic air | $0.90 \leq r_h \leq 1.1$ |
| (c) Toluene and purified synthetic air | $0.90 \leq r_h \leq 1.1$ |

These values are relative to a r_h of 1 for propane and purified synthetic air.

9.3.7.3. Oxygen interference check

For raw exhaust gas analyzers only, the oxygen interference check shall be determined when introducing an analyzer into service and after major service intervals.

A range shall be chosen where the oxygen interference check gases will fall in the upper 50 per cent. The test shall be conducted with the oven temperature set as required. Oxygen interference check gas specifications are found in paragraph 9.3.3.4.

- The analyzer shall be set at zero.
- The analyzer shall be spanned with the 0 per cent oxygen blend for positive ignition engines. Compression ignition engine instruments shall be spanned with the 21 per cent oxygen blend.
- The zero response shall be rechecked. If it has changed by more than 0.5 per cent of full scale, steps (a) and (b) of this paragraph shall be repeated.
- The 5 per cent and 10 per cent oxygen interference check gases shall be introduced.
- The zero response shall be rechecked. If it has changed by more than ± 1 per cent of full scale, the test shall be repeated.
- The oxygen interference E_{O_2} shall be calculated for each mixture in step d) as follows:

$$E_{O_2} = (c_{\text{ref,d}} - c) \times 100 / c_{\text{ref,d}} \quad (62)$$

with the analyzer response being

$$c = \frac{c_{\text{ref,b}} \times c_{\text{FS,b}}}{c_{\text{m,b}}} \times \frac{c_{\text{m,d}}}{c_{\text{FS,d}}} \quad (63)$$

where:

$c_{\text{ref,b}}$ is the reference HC concentration in step (b), ppm C

$c_{\text{ref,d}}$ is the reference HC concentration in step (d), ppm C

$c_{\text{FS,b}}$ is the full scale HC concentration in step (b), ppm C

$c_{\text{FS,d}}$ is the full scale HC concentration in step (d), ppm C

$c_{\text{m,b}}$ is the measured HC concentration in step (b), ppm C

$c_{\text{m,d}}$ is the measured HC concentration in step (d), ppm C

- (g) The oxygen interference E_{O_2} shall be less than ± 1.5 per cent for all required oxygen interference check gases prior to testing.
- (h) If the oxygen interference E_{O_2} is greater than ± 1.5 per cent, corrective action may be taken by incrementally adjusting the airflow above and below the manufacturer's specifications, the fuel flow and the sample flow.
- (i) The oxygen interference shall be repeated for each new setting.

9.3.8. Efficiency of the non-methane cutter (NMC)

The NMC is used for the removal of the non-methane hydrocarbons from the sample gas by oxidizing all hydrocarbons except methane. Ideally, the conversion for methane is 0 per cent, and for the other hydrocarbons represented by ethane is 100 per cent. For the accurate measurement of NMHC, the two efficiencies shall be determined and used for the calculation of the NMHC emission mass flow rate (see paragraph 8.5.1.).

9.3.8.1. Methane Efficiency

Methane calibration gas shall be flown through the FID with and without bypassing the NMC and the two concentrations recorded. The efficiency shall be determined as follows:

$$E_M = 1 - \frac{c_{HC(w/cutter)}}{c_{HC(w/o cutter)}} \quad (64)$$

where:

$c_{HC(w/cutter)}$ is the HC concentration with CH_4 flowing through the NMC, ppm C
 $c_{HC(w/o cutter)}$ is the HC concentration with CH_4 bypassing the NMC, ppm C

9.3.8.2. Ethane Efficiency

Ethane calibration gas shall be flown through the FID with and without bypassing the NMC and the two concentrations recorded. The efficiency shall be determined as follows:

$$E_E = 1 - \frac{c_{HC(w/cutter)}}{c_{HC(w/o cutter)}} \quad (65)$$

where:

$c_{HC(w/cutter)}$ is the HC concentration with C_2H_6 flowing through the NMC, ppm C
 $c_{HC(w/o cutter)}$ is the HC concentration with C_2H_6 bypassing the NMC, ppm C

9.3.9. Interference effects

Other gases than the one being analyzed can interfere with the reading in several ways. Positive interference occurs in NDIR instruments where the interfering gas gives the same effect as the gas being measured, but to a lesser degree. Negative interference occurs in NDIR instruments by the interfering gas broadening the absorption band of the measured gas, and in CLD instruments by the interfering gas quenching the reaction. The interference checks in paragraphs 9.3.9.1. and 9.3.9.2. shall be performed prior to an analyzer's initial use and after major service intervals.

9.3.9.1. CO analyzer interference check

Water and CO₂ can interfere with the CO analyzer performance. Therefore, a CO₂ span gas having a concentration of 80 to 100 per cent of full scale of the maximum operating range used during testing shall be bubbled through water at room temperature and the analyzer response recorded. The analyzer response shall not be more than 1 per cent of full scale for ranges equal to or above 300 ppm or more than 3 ppm for ranges below 300 ppm.

9.3.9.2. NO_x analyzer quench checks

The two gases of concern for CLD (and HCLD) analyzers are CO₂ and water vapour. Quench responses to these gases are proportional to their concentrations, and therefore require test techniques to determine the quench at the highest expected concentrations experienced during testing.

9.3.9.2.1. CO₂ quench check

A CO₂ span gas having a concentration of 80 to 100 per cent of full scale of the maximum operating range shall be passed through the NDIR analyzer and the CO₂ value recorded as *A*. It shall then be diluted approximately 50 per cent with NO span gas and passed through the NDIR and CLD, with the CO₂ and NO values recorded as *B* and *C*, respectively. The CO₂ shall then be shut off and only the NO span gas be passed through the (H)CLD and the NO value recorded as *D*.

The per cent quench shall be calculated as follows:

$$E_{\text{CO}_2} = \left[1 - \left(\frac{(C \times A)}{(D \times A) - (D \times B)} \right) \right] \times 100 \quad (66)$$

where:

- A* is the undiluted CO₂ concentration measured with NDIR, per cent
- B* is the diluted CO₂ concentration measured with NDIR, per cent
- C* is the diluted NO concentration measured with (H)CLD, ppm
- D* is the undiluted NO concentration measured with (H)CLD, ppm

Alternative methods of diluting and quantifying of CO₂ and NO span gas values such as dynamic mixing/blending are permitted with the approval of the type approval or certification authority.

9.3.9.2.2. Water quench check

This check applies to wet gas concentration measurements only. Calculation of water quench shall consider dilution of the NO span gas with water vapour and scaling of water vapour concentration of the mixture to that expected during testing.

A NO span gas having a concentration of 80 per cent to 100 per cent of full scale of the normal operating range shall be passed through the (H) CLD and the NO value recorded as *D*. The NO span gas shall then be bubbled through water at room temperature and passed through the (H) CLD and the NO value recorded as *C*. The water temperature shall be determined and recorded as *F*. The mixture's saturation vapour pressure that corresponds to the bubbler water temperature (*F*) shall be determined and recorded as *G*.

The water vapour concentration (in per cent) of the mixture shall be calculated as follows:

$$H = 100 \times (G / p_b) \quad (67)$$

and recorded as *H*. The expected diluted NO span gas (in water vapour) concentration shall be calculated as follows:

$$D_e = D \times (1 - H / 100) \quad (68)$$

and recorded as *D_e*. For diesel exhaust, the maximum exhaust water vapour concentration (in per cent) expected during testing shall be estimated, under the assumption of a fuelH/C ratio of 1.8/1, from the maximum CO₂ concentration in the exhaust gas *A* as follows:

$$H_m = 0.9 \times A \quad (69)$$

and recorded as *H_m*

The per cent water quench shall be calculated as follows:

$$E_{H_2O} = 100 \times ((D_e - C) / D_e) \times (H_m / H) \quad (70)$$

where:

D_e is the expected diluted NO concentration, ppm

C is the measured diluted NO concentration, ppm

H_m is the maximum water vapour concentration, per cent

H is the actual water vapour concentration, per cent

9.3.9.2.3. Maximum allowable quench

- (a) For raw measurement:
 - (i) CO₂ quench according to paragraph 9.3.9.2.1.: 2 per cent of full scale
 - (ii) water quench according to paragraph 9.3.9.2.2.: 3 per cent of full scale
- (b) For dilute measurement:
 - (i) 2 per cent combined CO₂ and water quench.

9.3.9.2.4. Efficiency of the cooling bath

For dry CLD analyzers, it shall be demonstrated that for the highest expected water vapour concentration H_m (see paragraph 9.3.9.2.2.), the water removal technique maintains CLD humidity at = 5 g water/kg dry air (or about 0.008 per cent H₂O), which is 100 per cent relative humidity at 3.9 °C and 101.3 kPa. This humidity specification is also equivalent to about 25 per cent relative humidity at 25 °C and 101.3 kPa. This may be demonstrated by measuring the temperature at the outlet of a thermal dehumidifier, or by measuring humidity at a point just upstream of the CLD. Humidity of the CLD exhaust might also be measured as long as the only flow into the CLD is the flow of the dehumidifier.

9.4. Particulate measurement and sampling system

9.4.1. General specifications

To determine the mass of the particulates, a particulate sampling system, particulate sampling filters, a microgram balance, and a temperature and humidity controlled weighing chamber, are required. The particulate sampling system shall be designed to ensure a representative sample of the particulates proportional to the exhaust flow.

9.4.2. Particulate sampling filters

The diluted exhaust shall be sampled by a filter that meets the requirements of paragraphs 9.4.2.1. to 9.4.2.3. during the test sequence. Selection of the options in paragraphs 9.4.2.1. and 9.4.2.2. shall be decided by the Contracting Parties.

9.4.2.1. Filter specification

All filter types shall have a 0.3 µm DOP (di-octylphthalate) collection efficiency of at least 99 per cent. The filter material shall be either:

- (a) fluorocarbon (PTFE) coated glass fiber, or
- (b) fluorocarbon (PTFE) membrane.

9.4.2.2. Filter size

The filter size shall be either:

- (a) 47 mm diameter or
- (b) 70 mm diameter.

9.4.2.3. Filter face velocity

The face velocity through the filter shall not exceed 1 m/s. The pressure drop increase between the beginning and the end of the test shall not exceed 25 kPa.

9.4.3. Weighing chamber and analytical balance specifications

9.4.3.1. Weighing chamber conditions

The temperature of the chamber (or room) in which the particulate filters are conditioned and weighed shall be maintained to within $295\text{ K} \pm 3\text{ K}$ ($22\text{ °C} \pm 3\text{ °C}$) during all filter conditioning and weighing. The humidity shall be maintained to a dew point of $282.5\text{ K} \pm 3\text{ K}$ ($9.5\text{ °C} \pm 3\text{ °C}$) and a relative humidity of 45 per cent \pm 8 per cent. For sensitive balances, it is recommended that the tolerance for the weighing chamber room air temperature and the dew point be $\pm 1\text{ K}$.

9.4.3.2. Reference filter weighing

The chamber (or room) environment shall be free of any ambient contaminants (such as dust) that would settle on the particulate filters during their stabilization. Disturbances to weighing room specifications as outlined in paragraph 9.4.3.1. will be allowed if the duration of the disturbances does not exceed 30 minutes. The weighing room shall meet the required specifications prior to personal entrance into the weighing room. At least two unused reference filters shall be weighed within 12 hours of, but preferably at the same time as the sample filter weighing. They shall be the same size and material as the sample filters.

If the average weight of the reference filters changes between sample filter weightings by more than 10 μg , all sample filters shall be discarded and the emissions test repeated.

9.4.3.3. Analytical balance

The analytical balance used to determine the filter weight shall meet the linearity verification criterion of paragraph 9.2., table 6. This implies a precision (standard deviation) of at least 2 μg and a resolution of at least 1 μg (1 digit = 1 μg).

9.4.3.4. Elimination of static electricity effects

The filters shall be neutralized prior to weighing, e.g. by a Polonium neutralizer or a device of similar effect.

9.4.3.5. Buoyancy correction

The sampling filters shall be corrected for their buoyancy in air. The buoyancy correction depends on sampling filter density, air density and the density of the balance calibration weight, and does not account for the buoyancy of the PM itself.

If the density of the filter material is not known, the following densities shall be used:

- (a) teflon coated glass fiber filter: 2,300 kg/m³
- (b) teflon membrane filter: 2,144 kg/m³
- (c) teflon membrane filter with polymethylpentene support ring: 920 kg/m³

For stainless steel calibration weights, a density of 8,000 kg/m³ shall be used. If the material of the calibration weight is different, its density must be known.

The following equation shall be used:

$$m_f = m_{\text{uncor}} \times \left(\frac{1 - \frac{r_a}{r_w}}{1 - \frac{r_a}{r_f}} \right) \quad (71)$$

with

$$r_a = \frac{p_b \times 28.836}{8.3144 \times T_a} \quad (72)$$

where:

m_{uncor}	is the uncorrected particulate sample mass, mg
r_a	is the density of the air, kg/m ³
r_w	is the density of balance calibration weight, kg/m ³
r_f	is the density of the particulate sampling filter, kg/m ³
p_b	is the total atmospheric pressure, kPa
T_a	is the air temperature in the balance environment, K
28.836	is the molar mass of the air at reference humidity (9.5 K), g/mol
8.3144	is the molar gas constant

9.4.4. Specifications for flow measurement

For partial flow dilution systems, the accuracy of the sample flow q_{m_p} is of special concern, if not measured directly, but determined by differential flow measurement:

$$q_{m_p} = q_{m_{dew}} - q_{m_{dw}} \quad (73)$$

In this case, the maximum error of the difference shall be such that the accuracy of q_{m_p} is within ± 5 per cent when the dilution ratio is less than 15. It can be calculated by taking root-mean-square of the errors of each instrument.

Acceptable accuracies of q_{m_p} can be obtained by either of the following methods:

- (a) The absolute accuracies of $q_{m_{dew}}$ and $q_{m_{dw}}$ are ± 0.2 per cent which guarantees an accuracy of q_{m_p} of ≤ 5 per cent at a dilution ratio of 15. However, greater errors will occur at higher dilution ratios.
- (b) Calibration of $q_{m_{dw}}$ relative to $q_{m_{dew}}$ is carried out such that the same accuracies for q_{m_p} as in (a) are obtained. For details see paragraph 9.4.6.2.
- (c) The accuracy of q_{m_p} is determined indirectly from the accuracy of the dilution ratio as determined by a tracer gas, e.g. CO₂. Accuracies equivalent to method (a) for q_{m_p} are required.
- (d) The absolute accuracy of $q_{m_{dew}}$ and $q_{m_{dw}}$ is within ± 2 per cent of full scale, the maximum error of the difference between $q_{m_{dew}}$ and $q_{m_{dw}}$ is within 0.2 per cent, and the linearity error is within ± 0.2 per cent of the highest $q_{m_{dew}}$ observed during the test.

9.4.5. Additional specifications

All parts of the dilution system and the sampling system from the exhaust pipe up to the filter holder, which are in contact with raw and diluted exhaust gas, shall be designed to minimize deposition or alteration of the particulates. All parts shall be made of electrically conductive materials that do not react with exhaust gas components, and shall be electrically grounded to prevent electrostatic effects.

9.4.6. Calibration of the partial flow dilution system

9.4.6.1. Introduction

The calibration of the particulate measurement is limited to the flowmeters used to determine sample flow and dilution ratio. Each flowmeter shall be calibrated as often as necessary to fulfil the accuracy requirements of this part. The calibration method that shall be used is described in paragraph 9.4.6.2.

9.4.6.2. Flow measurement

9.4.6.2.1. Periodical calibration

The flowmeter or the flow measurement instrumentation shall be calibrated with an accurate flowmeter traceable to international and/or national standards.

If the sample gas flow is determined by differential flow measurement, the flowmeter or the flow measurement instrumentation shall be calibrated in one of the following procedures, such that the probe flow q_{m_p} into the tunnel shall fulfil the accuracy requirements of paragraph 9.4.4.:

- (a) The flowmeter for $q_{m_{dw}}$ shall be connected in series to the flowmeter for $q_{m_{dew}}$, the difference between the two flowmeters shall be calibrated for at least 5 set points with flow values equally spaced between the lowest $q_{m_{dw}}$ value used during the test and the value of $q_{m_{dew}}$ used during the test. The dilution tunnel may be bypassed.
- (b) A calibrated flow device shall be connected in series to the flowmeter for $q_{m_{dew}}$ and the accuracy shall be checked for the value used for the test. The calibrated flow device shall be connected in series to the flowmeter for $q_{m_{dw}}$, and the accuracy shall be checked for at least 5 settings corresponding to dilution ratio between 3 and 50, relative to $q_{m_{dew}}$ used during the test.
- (c) The transfer tube (TT) shall be disconnected from the exhaust, and a calibrated flow-measuring device with a suitable range to measure q_{m_p} shall be connected to the transfer tube. $q_{m_{dew}}$ shall be set to the value used during the test, and $q_{m_{dw}}$ shall be sequentially set to at least 5 values corresponding to dilution ratios between 3 and 50. Alternatively, a special calibration flow path may be provided, in which the tunnel is bypassed, but the total and dilution airflow through the corresponding meters as in the actual test.
- (d) A tracer gas, shall be fed into the exhaust transfer tube TT. This tracer gas may be a component of the exhaust gas, like CO₂ or NO_x. After dilution in the tunnel the tracer gas component shall be measured. This shall be carried out for 5 dilution ratios between 3 and 50. The accuracy of the sample flow shall be determined from the dilution ration r_d :

$$q_{m_p} = q_{m_{dew}} / r_d \quad (74)$$

The accuracies of the gas analyzers shall be taken into account to guarantee the accuracy of q_{m_p} .

9.4.6.2.2. Carbon flow check

A carbon flow check using actual exhaust is strongly recommended for detecting measurement and control problems and verifying the proper operation of the partial flow system. The carbon flow check should be run at least each time a new engine is installed, or something significant is changed in the test cell configuration.

The engine shall be operated at peak torque load and speed or any other steady state mode that produces 5 per cent or more of CO₂. The partial flow sampling system shall be operated with a dilution factor of about 15 to 1.

If a carbon flow check is conducted, the procedure given in annex 5 shall be applied. The carbon flow rates shall be calculated according to equations 80 to 82 in annex 5. All carbon flow rates should agree to within 3 per cent.

9.4.6.2.3. Pre-test check

A pre-test check shall be performed within 2 hours before the test run in the following way.

The accuracy of the flowmeters shall be checked by the same method as used for calibration (see paragraph 9.4.6.2.1.) for at least two points, including flow values of $q_{m_{dw}}$ that correspond to dilution ratios between 5 and 15 for the $q_{m_{dew}}$ value used during the test.

If it can be demonstrated by records of the calibration procedure under paragraph 9.4.6.2.1. that the flowmeter calibration is stable over a longer period of time, the pre-test check may be omitted.

9.4.6.3. Determination of the transformation time

The system settings for the transformation time evaluation shall be exactly the same as during measurement of the test run. The transformation time shall be determined by the following method.

An independent reference flowmeter with a measurement range appropriate for the probe flow shall be put in series with and closely coupled to the probe. This flowmeter shall have a transformation time of less than 100 ms for the flow step size used in the response time measurement, with flow restriction sufficiently low as to not affect the dynamic performance of the partial flow dilution system, and consistent with good engineering practice.

A step change shall be introduced to the exhaust flow (or airflow if exhaust flow is calculated) input of the partial flow dilution system, from a low flow to at least 90 per cent of full scale. The trigger for the step change shall be the same one used to start the look-ahead control in actual testing. The exhaust flow step stimulus and the flowmeter response shall be recorded at a sample rate of at least 10 Hz.

From this data, the transformation time shall be determined for the partial flow dilution system, which is the time from the initiation of the step stimulus to the 50 per cent point of the flowmeter response. In a similar manner, the transformation times of the q_{mp} signal of the partial flow dilution system and of the $q_{mew,i}$ signal of the exhaust flowmeter shall be determined. These signals are used in the regression checks performed after each test (see paragraph 8.3.3.3.)

The calculation shall be repeated for at least 5 rise and fall stimuli, and the results shall be averaged. The internal transformation time (< 100 ms) of the reference flowmeter

shall be subtracted from this value. This is the "look-ahead" value of the partial flow dilution system, which shall be applied in accordance with paragraph 8.3.3.3.

9.5. Calibration of the CVS system

9.5.1. General

The CVS system shall be calibrated by using an accurate flowmeter and a restricting device. The flow through the system shall be measured at different restriction settings, and the control parameters of the system shall be measured and related to the flow.

Various types of flowmeters may be used, e.g. calibrated venturi, calibrated laminar flowmeter, calibrated turbine meter.

9.5.2. Calibration of the positive displacement pump (PDP)

All the parameters related to the pump shall be simultaneously measured along with the parameters related to a calibration venturi which is connected in series with the pump. The calculated flow rate (in m³/s at pump inlet, absolute pressure and temperature) shall be plotted versus a correlation function which is the value of a specific combination of pump parameters. The linear equation which relates the pump flow and the correlation function shall be determined. If a CVS has a multiple speed drive, the calibration shall be performed for each range used.

Temperature stability shall be maintained during calibration.

Leaks in all the connections and ducting between the calibration venturi and the CVS pump shall be maintained lower than 0.3 per cent of the lowest flow point (highest restriction and lowest PDP speed point).

9.5.2.1. Data analysis

The airflow rate (q_{CVS}) at each restriction setting (minimum 6 settings) shall be calculated in standard m³/s from the flowmeter data using the manufacturer's prescribed method. The airflow rate shall then be converted to pump flow (V_0) in m³/rev at absolute pump inlet temperature and pressure as follows:

$$V_0 = \frac{q_{\text{CVS}}}{n} \times \frac{T}{273} \times \frac{101.3}{p_p} \quad (75)$$

where:

q_{CVS} is the airflow rate at standard conditions (101.3 kPa, 273 K), m³/s

T is the temperature at pump inlet, K

p_p is the absolute pressure at pump inlet, kPa

n is the pump speed, rev/s

To account for the interaction of pressure variations at the pump and the pump slip rate, the correlation function (X_0) between pump speed, pressure differential from pump inlet to pump outlet and absolute pump outlet pressure shall be calculated as follows:

$$X_0 = \frac{1}{n} \times \sqrt{\frac{\Delta p_p}{p_p}} \quad (76)$$

where:

Δp_p is the pressure differential from pump inlet to pump outlet, kPa

p_p is the absolute outlet pressure at pump outlet, kPa

A linear least-square fit shall be performed to generate the calibration equation as follows:

$$V_0 = D_0 - m \times X_0 \quad (77)$$

D_0 and m are the intercept and slope, respectively, describing the regression lines.

For a CVS system with multiple speeds, the calibration curves generated for the different pump flow ranges shall be approximately parallel, and the intercept values (D_0) shall increase as the pump flow range decreases.

The calculated values from the equation shall be within ± 0.5 per cent of the measured value of V_0 . Values of m will vary from one pump to another. Particulate influx over time will cause the pump slip to decrease, as reflected by lower values for m . Therefore, calibration shall be performed at pump start-up, after major maintenance, and if the total system verification indicates a change of the slip rate.

9.5.3. Calibration of the critical flow venturi (CFV)

Calibration of the CFV is based upon the flow equation for a critical venturi. Gas flow is a function of venturi inlet pressure and temperature.

To determine the range of critical flow, K_v shall be plotted as a function of venturi inlet pressure. For critical (choked) flow, K_v will have a relatively constant value. As pressure decreases (vacuum increases), the venturi becomes unchoked and K_v decreases, which indicates that the CFV is operated outside the permissible range.

9.5.3.1. Data analysis

The airflow rate (q_{vCVS}) at each restriction setting (minimum 8 settings) shall be calculated in standard m^3/s from the flowmeter data using the manufacturer's prescribed method. The calibration coefficient shall be calculated from the calibration data for each setting as follows:

$$K_v = \frac{q_{v, CVS} \times \sqrt{T}}{p_p} \quad (78)$$

where:

$q_{v, CVS}$ is the airflow rate at standard conditions (101.3 kPa, 273 K), m³/s

T is the temperature at the venturi inlet, K

p_p is the absolute pressure at venturi inlet, kPa

The average K_v and the standard deviation shall be calculated. The standard deviation shall not exceed ± 0.3 per cent of the average K_v .

9.5.4. Calibration of the subsonic venturi (SSV)

Calibration of the SSV is based upon the flow equation for a subsonic venturi. Gas flow is a function of inlet pressure and temperature, pressure drop between the SSV inlet and throat, as shown in equation 43 (see paragraph 8.4.1.4.).

9.5.4.1. Data analysis

The airflow rate (Q_{SSV}) at each restriction setting (minimum 16 settings) shall be calculated in standard m³/s from the flowmeter data using the manufacturer's prescribed method. The discharge coefficient shall be calculated from the calibration data for each setting as follows:

$$C_d = \frac{Q_{SSV}}{d_v^2 \times p_p \times \sqrt{\left[\frac{1}{T} \times (r_p^{1.4286} - r_p^{1.7143}) \times \left(\frac{1}{1 - r_D^4 \times r_p^{1.4286}} \right) \right]}} \quad (79)$$

where:

Q_{SSV} is the airflow rate at standard conditions (101.3 kPa, 273 K), m³/s

T is the temperature at the venturi inlet, K

d_v is the diameter of the SSV throat, m

r_p is the ratio of the SSV throat to inlet absolute static pressure = $1 - \frac{\Delta p}{p_p}$

r_D is the ratio of the SSV throat diameter, d_v , to the inlet pipe inner diameter D

To determine the range of subsonic flow, C_d shall be plotted as a function of Reynolds number Re , at the SSV throat. The Re at the SSV throat shall be calculated with the following equation:

$$Re = A_1 \times \frac{Q_{SSV}}{d_v \times \mathbf{m}} \quad (80)$$

with

$$m = \frac{b \times T^{1.5}}{S + T} \quad (81)$$

where:

A_1 is 25.55152 in SI units of $\left(\frac{1}{m^3}\right)\left(\frac{\text{min}}{s}\right)\left(\frac{\text{mm}}{m}\right)$

Q_{SSV} is the airflow rate at standard conditions (101.3 kPa, 273 K), m^3/s

d_v is the diameter of the SSV throat, m

μ is the absolute or dynamic viscosity of the gas, kg/ms

b is 1.458×10^6 (empirical constant), $\text{kg/ms K}^{0.5}$

S is 110.4 (empirical constant), K

Because Q_{SSV} is an input to the Re equation, the calculations must be started with an initial guess for Q_{SSV} or C_d of the calibration venturi, and repeated until Q_{SSV} converges. The convergence method shall be accurate to 0.1 per cent of point or better.

For a minimum of sixteen points in the region of subsonic flow, the calculated values of C_d from the resulting calibration curve fit equation must be within ± 0.5 per cent of the measured C_d for each calibration point.

9.5.5. Total system verification

The total accuracy of the CVS sampling system and analytical system shall be determined by introducing a known mass of a pollutant gas into the system while it is being operated in the normal manner. The pollutant is analyzed, and the mass calculated according to paragraph 8.4.2.4. except in the case of propane where a u factor of 0.000472 is used in place of 0.000480 for HC. Either of the following two techniques shall be used.

9.5.5.1. Metering with a critical flow orifice

A known quantity of pure gas (carbon monoxide or propane) shall be fed into the CVS system through a calibrated critical orifice. If the inlet pressure is high enough, the flow rate, which is adjusted by means of the critical flow orifice, is independent of the orifice outlet pressure (critical flow). The CVS system shall be operated as in a normal exhaust emission test for about 5 to 10 minutes. A gas sample shall be analyzed with the usual equipment (sampling bag or integrating method), and the mass of the gas calculated. The mass so determined shall be within ± 3 per cent of the known mass of the gas injected.

9.5.5.2. Metering by means of a gravimetric technique

The mass of a small cylinder filled with carbon monoxide or propane shall be determined with a precision of ± 0.01 g. For about 5 to 10 minutes, the CVS system shall be operated as in a normal exhaust emission test, while carbon monoxide or propane is injected into the system. The quantity of pure gas discharged shall be determined by means of differential weighing. A gas sample shall be analyzed with the usual equipment (sampling bag or integrating method), and the mass of the gas calculated. The mass so determined shall be within ± 3 per cent of the known mass of the gas injected.

Annex 1

WHTC ENGINE DYNAMOMETER SCHEDULE

Time	Norm. Speed	Norm. Torque	Time	Norm. Speed	Norm. Torque	Time	Norm. Speed	Norm. Torque
s	per cent	per cent	s	per cent	per cent	s	per cent	per cent
1	0.0	0.0	47	0.0	0.0	93	32.8	32.7
2	0.0	0.0	48	0.0	0.0	94	33.7	32.5
3	0.0	0.0	49	0.0	0.0	95	34.4	29.5
4	0.0	0.0	50	0.0	13.1	96	34.3	26.5
5	0.0	0.0	51	13.1	30.1	97	34.4	24.7
6	0.0	0.0	52	26.3	25.5	98	35.0	24.9
7	1.5	8.9	53	35.0	32.2	99	35.6	25.2
8	15.8	30.9	54	41.7	14.3	100	36.1	24.8
9	27.4	1.3	55	42.2	0.0	101	36.3	24.0
10	32.6	0.7	56	42.8	11.6	102	36.2	23.6
11	34.8	1.2	57	51.0	20.9	103	36.2	23.5
12	36.2	7.4	58	60.0	9.6	104	36.8	22.7
13	37.1	6.2	59	49.4	0.0	105	37.2	20.9
14	37.9	10.2	60	38.9	16.6	106	37.0	19.2
15	39.6	12.3	61	43.4	30.8	107	36.3	18.4
16	42.3	12.5	62	49.4	14.2	108	35.4	17.6
17	45.3	12.6	63	40.5	0.0	109	35.2	14.9
18	48.6	6.0	64	31.5	43.5	110	35.4	9.9
19	40.8	0.0	65	36.6	78.2	111	35.5	4.3
20	33.0	16.3	66	40.8	67.6	112	35.2	6.6
21	42.5	27.4	67	44.7	59.1	113	34.9	10.0
22	49.3	26.7	68	48.3	52.0	114	34.7	25.1
23	54.0	18.0	69	51.9	63.8	115	34.4	29.3
24	57.1	12.9	70	54.7	27.9	116	34.5	20.7
25	58.9	8.6	71	55.3	18.3	117	35.2	16.6
26	59.3	6.0	72	55.1	16.3	118	35.8	16.2
27	59.0	4.9	73	54.8	11.1	119	35.6	20.3
28	57.9	m	74	54.7	11.5	120	35.3	22.5
29	55.7	m	75	54.8	17.5	121	35.3	23.4
30	52.1	m	76	55.6	18.0	122	34.7	11.9
31	46.4	m	77	57.0	14.1	123	45.5	0.0
32	38.6	m	78	58.1	7.0	124	56.3	m
33	29.0	m	79	43.3	0.0	125	46.2	m
34	20.8	m	80	28.5	25.0	126	50.1	0.0
35	16.9	m	81	30.4	47.8	127	54.0	m
36	16.9	42.5	82	32.1	39.2	128	40.5	m
37	18.8	38.4	83	32.7	39.3	129	27.0	m
38	20.7	32.9	84	32.4	17.3	130	13.5	m
39	21.0	0.0	85	31.6	11.4	131	0.0	0.0
40	19.1	0.0	86	31.1	10.2	132	0.0	0.0
41	13.7	0.0	87	31.1	19.5	133	0.0	0.0
42	2.2	0.0	88	31.4	22.5	134	0.0	0.0
43	0.0	0.0	89	31.6	22.9	135	0.0	0.0
44	0.0	0.0	90	31.6	24.3	136	0.0	0.0
45	0.0	0.0	91	31.9	26.9	137	0.0	0.0
46	0.0	0.0	92	32.4	30.6	138	0.0	0.0

Time s	Norm. Speed per cent	Norm. Torque per cent	Time s	Norm. Speed per cent	Norm. Torque per cent	Time s	Norm. Speed per cent	Norm. Torque per cent
139	0.0	0.0	189	0.0	5.9	239	0.0	0.0
140	0.0	0.0	190	0.0	0.0	240	0.0	0.0
141	0.0	0.0	191	0.0	0.0	241	0.0	0.0
142	0.0	4.9	192	0.0	0.0	242	0.0	0.0
143	0.0	7.3	193	0.0	0.0	243	0.0	0.0
144	4.4	28.7	194	0.0	0.0	244	0.0	0.0
145	11.1	26.4	195	0.0	0.0	245	0.0	0.0
146	15.0	9.4	196	0.0	0.0	246	0.0	0.0
147	15.9	0.0	197	0.0	0.0	247	0.0	0.0
148	15.3	0.0	198	0.0	0.0	248	0.0	0.0
149	14.2	0.0	199	0.0	0.0	249	0.0	0.0
150	13.2	0.0	200	0.0	0.0	250	0.0	0.0
151	11.6	0.0	201	0.0	0.0	251	0.0	0.0
152	8.4	0.0	202	0.0	0.0	252	0.0	0.0
153	5.4	0.0	203	0.0	0.0	253	0.0	31.6
154	4.3	5.6	204	0.0	0.0	254	9.4	13.6
155	5.8	24.4	205	0.0	0.0	255	22.2	16.9
156	9.7	20.7	206	0.0	0.0	256	33.0	53.5
157	13.6	21.1	207	0.0	0.0	257	43.7	22.1
158	15.6	21.5	208	0.0	0.0	258	39.8	0.0
159	16.5	21.9	209	0.0	0.0	259	36.0	45.7
160	18.0	22.3	210	0.0	0.0	260	47.6	75.9
161	21.1	46.9	211	0.0	0.0	261	61.2	70.4
162	25.2	33.6	212	0.0	0.0	262	72.3	70.4
163	28.1	16.6	213	0.0	0.0	263	76.0	m
164	28.8	7.0	214	0.0	0.0	264	74.3	m
165	27.5	5.0	215	0.0	0.0	265	68.5	m
166	23.1	3.0	216	0.0	0.0	266	61.0	m
167	16.9	1.9	217	0.0	0.0	267	56.0	m
168	12.2	2.6	218	0.0	0.0	268	54.0	m
169	9.9	3.2	219	0.0	0.0	269	53.0	m
170	9.1	4.0	220	0.0	0.0	270	50.8	m
171	8.8	3.8	221	0.0	0.0	271	46.8	m
172	8.5	12.2	222	0.0	0.0	272	41.7	m
173	8.2	29.4	223	0.0	0.0	273	35.9	m
174	9.6	20.1	224	0.0	0.0	274	29.2	m
175	14.7	16.3	225	0.0	0.0	275	20.7	m
176	24.5	8.7	226	0.0	0.0	276	10.1	m
177	39.4	3.3	227	0.0	0.0	277	0.0	m
178	39.0	2.9	228	0.0	0.0	278	0.0	0.0
179	38.5	5.9	229	0.0	0.0	279	0.0	0.0
180	42.4	8.0	230	0.0	0.0	280	0.0	0.0
181	38.2	6.0	231	0.0	0.0	281	0.0	0.0
182	41.4	3.8	232	0.0	0.0	282	0.0	0.0
183	44.6	5.4	233	0.0	0.0	283	0.0	0.0
184	38.8	8.2	234	0.0	0.0	284	0.0	0.0
185	37.5	8.9	235	0.0	0.0	285	0.0	0.0
186	35.4	7.3	236	0.0	0.0	286	0.0	0.0
187	28.4	7.0	237	0.0	0.0	287	0.0	0.0
188	14.8	7.0	238	0.0	0.0	288	0.0	0.0

Time	Norm. Speed	Norm. Torque	Time	Norm. Speed	Norm. Torque	Time	Norm. Speed	Norm. Torque
s	per cent	per cent	s	per cent	per cent	s	per cent	per cent
289	0.0	0.0	339	0.0	0.0	389	25.2	14.7
290	0.0	0.0	340	0.0	0.0	390	28.6	28.4
291	0.0	0.0	341	0.0	0.0	391	35.5	65.0
292	0.0	0.0	342	0.0	0.0	392	43.8	75.3
293	0.0	0.0	343	0.0	0.0	393	51.2	34.2
294	0.0	0.0	344	0.0	0.0	394	40.7	0.0
295	0.0	0.0	345	0.0	0.0	395	30.3	45.4
296	0.0	0.0	346	0.0	0.0	396	34.2	83.1
297	0.0	0.0	347	0.0	0.0	397	37.6	85.3
298	0.0	0.0	348	0.0	0.0	398	40.8	87.5
299	0.0	0.0	349	0.0	0.0	399	44.8	89.7
300	0.0	0.0	350	0.0	0.0	400	50.6	91.9
301	0.0	0.0	351	0.0	0.0	401	57.6	94.1
302	0.0	0.0	352	0.0	0.0	402	64.6	44.6
303	0.0	0.0	353	0.0	0.0	403	51.6	0.0
304	0.0	0.0	354	0.0	0.5	404	38.7	37.4
305	0.0	0.0	355	0.0	4.9	405	42.4	70.3
306	0.0	0.0	356	9.2	61.3	406	46.5	89.1
307	0.0	0.0	357	22.4	40.4	407	50.6	93.9
308	0.0	0.0	358	36.5	50.1	408	53.8	33.0
309	0.0	0.0	359	47.7	21.0	409	55.5	20.3
310	0.0	0.0	360	38.8	0.0	410	55.8	5.2
311	0.0	0.0	361	30.0	37.0	411	55.4	m
312	0.0	0.0	362	37.0	63.6	412	54.4	m
313	0.0	0.0	363	45.5	90.8	413	53.1	m
314	0.0	0.0	364	54.5	40.9	414	51.8	m
315	0.0	0.0	365	45.9	0.0	415	50.3	m
316	0.0	0.0	366	37.2	47.5	416	48.4	m
317	0.0	0.0	367	44.5	84.4	417	45.9	m
318	0.0	0.0	368	51.7	32.4	418	43.1	m
319	0.0	0.0	369	58.1	15.2	419	40.1	m
320	0.0	0.0	370	45.9	0.0	420	37.4	m
321	0.0	0.0	371	33.6	35.8	421	35.1	m
322	0.0	0.0	372	36.9	67.0	422	32.8	m
323	0.0	0.0	373	40.2	84.7	423	45.3	0.0
324	4.5	41.0	374	43.4	84.3	424	57.8	m
325	17.2	38.9	375	45.7	84.3	425	50.6	m
326	30.1	36.8	376	46.5	m	426	41.6	m
327	41.0	34.7	377	46.1	m	427	47.9	0.0
328	50.0	32.6	378	43.9	m	428	54.2	m
329	51.4	0.1	379	39.3	m	429	48.1	m
330	47.8	m	380	47.0	m	430	47.0	31.3
331	40.2	m	381	54.6	m	431	49.0	38.3
332	32.0	m	382	62.0	m	432	52.0	40.1
333	24.4	m	383	52.0	m	433	53.3	14.5
334	16.8	m	384	43.0	m	434	52.6	0.8
335	8.1	m	385	33.9	m	435	49.8	m
336	0.0	m	386	28.4	m	436	51.0	18.6
337	0.0	0.0	387	25.5	m	437	56.9	38.9
338	0.0	0.0	388	24.6	11.0	438	67.2	45.0

Time	Norm. Speed s per cent	Norm. Torque per cent	Time	Norm. Speed s per cent	Norm. Torque per cent	Time	Norm. Speed s per cent	Norm. Torque per cent
439	78.6	21.5	489	45.5	m	539	56.7	m
440	65.5	0.0	490	40.4	m	540	46.9	m
441	52.4	31.3	491	49.7	0.0	541	37.5	m
442	56.4	60.1	492	59.0	m	542	30.3	m
443	59.7	29.2	493	48.9	m	543	27.3	32.3
444	45.1	0.0	494	40.0	m	544	30.8	60.3
445	30.6	4.2	495	33.5	m	545	41.2	62.3
446	30.9	8.4	496	30.0	m	546	36.0	0.0
447	30.5	4.3	497	29.1	12.0	547	30.8	32.3
448	44.6	0.0	498	29.3	40.4	548	33.9	60.3
449	58.8	m	499	30.4	29.3	549	34.6	38.4
450	55.1	m	500	32.2	15.4	550	37.0	16.6
451	50.6	m	501	33.9	15.8	551	42.7	62.3
452	45.3	m	502	35.3	14.9	552	50.4	28.1
453	39.3	m	503	36.4	15.1	553	40.1	0.0
454	49.1	0.0	504	38.0	15.3	554	29.9	8.0
455	58.8	m	505	40.3	50.9	555	32.5	15.0
456	50.7	m	506	43.0	39.7	556	34.6	63.1
457	42.4	m	507	45.5	20.6	557	36.7	58.0
458	44.1	0.0	508	47.3	20.6	558	39.4	52.9
459	45.7	m	509	48.8	22.1	559	42.8	47.8
460	32.5	m	510	50.1	22.1	560	46.8	42.7
461	20.7	m	511	51.4	42.4	561	50.7	27.5
462	10.0	m	512	52.5	31.9	562	53.4	20.7
463	0.0	0.0	513	53.7	21.6	563	54.2	13.1
464	0.0	1.5	514	55.1	11.6	564	54.2	0.4
465	0.9	41.1	515	56.8	5.7	565	53.4	0.0
466	7.0	46.3	516	42.4	0.0	566	51.4	m
467	12.8	48.5	517	27.9	8.2	567	48.7	m
468	17.0	50.7	518	29.0	15.9	568	45.6	m
469	20.9	52.9	519	30.4	25.1	569	42.4	m
470	26.7	55.0	520	32.6	60.5	570	40.4	m
471	35.5	57.2	521	35.4	72.7	571	39.8	5.8
472	46.9	23.8	522	38.4	88.2	572	40.7	39.7
473	44.5	0.0	523	41.0	65.1	573	43.8	37.1
474	42.1	45.7	524	42.9	25.6	574	48.1	39.1
475	55.6	77.4	525	44.2	15.8	575	52.0	22.0
476	68.8	100.0	526	44.9	2.9	576	54.7	13.2
477	81.7	47.9	527	45.1	m	577	56.4	13.2
478	71.2	0.0	528	44.8	m	578	57.5	6.6
479	60.7	38.3	529	43.9	m	579	42.6	0.0
480	68.8	72.7	530	42.4	m	580	27.7	10.9
481	75.0	m	531	40.2	m	581	28.5	21.3
482	61.3	m	532	37.1	m	582	29.2	23.9
483	53.5	m	533	47.0	0.0	583	29.5	15.2
484	45.9	58.0	534	57.0	m	584	29.7	8.8
485	48.1	80.0	535	45.1	m	585	30.4	20.8
486	49.4	97.9	536	32.6	m	586	31.9	22.9
487	49.7	m	537	46.8	0.0	587	34.3	61.4
488	48.7	m	538	61.5	m	588	37.2	76.6

Time	Norm. Speed	Norm. Torque	Time	Norm. Speed	Norm. Torque	Time	Norm. Speed	Norm. Torque
s	per cent	per cent	s	per cent	per cent	s	per cent	per cent
589	40.1	27.5	639	39.8	m	689	46.6	0.0
590	42.3	25.4	640	36.0	m	690	32.3	34.6
591	43.5	32.0	641	29.7	m	691	32.7	68.6
592	43.8	6.0	642	21.5	m	692	32.6	67.0
593	43.5	m	643	14.1	m	693	31.3	m
594	42.8	m	644	0.0	0.0	694	28.1	m
595	41.7	m	645	0.0	0.0	695	43.0	0.0
596	40.4	m	646	0.0	0.0	696	58.0	m
597	39.3	m	647	0.0	0.0	697	58.9	m
598	38.9	12.9	648	0.0	0.0	698	49.4	m
599	39.0	18.4	649	0.0	0.0	699	41.5	m
600	39.7	39.2	650	0.0	0.0	700	48.4	0.0
601	41.4	60.0	651	0.0	0.0	701	55.3	m
602	43.7	54.5	652	0.0	0.0	702	41.8	m
603	46.2	64.2	653	0.0	0.0	703	31.6	m
604	48.8	73.3	654	0.0	0.0	704	24.6	m
605	51.0	82.3	655	0.0	0.0	705	15.2	m
606	52.1	0.0	656	0.0	3.4	706	7.0	m
607	52.0	m	657	1.4	22.0	707	0.0	0.0
608	50.9	m	658	10.1	45.3	708	0.0	0.0
609	49.4	m	659	21.5	10.0	709	0.0	0.0
610	47.8	m	660	32.2	0.0	710	0.0	0.0
611	46.6	m	661	42.3	46.0	711	0.0	0.0
612	47.3	35.3	662	57.1	74.1	712	0.0	0.0
613	49.2	74.1	663	72.1	34.2	713	0.0	0.0
614	51.1	95.2	664	66.9	0.0	714	0.0	0.0
615	51.7	m	665	60.4	41.8	715	0.0	0.0
616	50.8	m	666	69.1	79.0	716	0.0	0.0
617	47.3	m	667	77.1	38.3	717	0.0	0.0
618	41.8	m	668	63.1	0.0	718	0.0	0.0
619	36.4	m	669	49.1	47.9	719	0.0	0.0
620	30.9	m	670	53.4	91.3	720	0.0	0.0
621	25.5	37.1	671	57.5	85.7	721	0.0	0.0
622	33.8	38.4	672	61.5	89.2	722	0.0	0.0
623	42.1	m	673	65.5	85.9	723	0.0	0.0
624	34.1	m	674	69.5	89.5	724	0.0	0.0
625	33.0	37.1	675	73.1	75.5	725	0.0	0.0
626	36.4	38.4	676	76.2	73.6	726	0.0	0.0
627	43.3	17.1	677	79.1	75.6	727	0.0	0.0
628	35.7	0.0	678	81.8	78.2	728	0.0	0.0
629	28.1	11.6	679	84.1	39.0	729	0.0	0.0
630	36.5	19.2	680	69.6	0.0	730	0.0	0.0
631	45.2	8.3	681	55.0	25.2	731	0.0	0.0
632	36.5	0.0	682	55.8	49.9	732	0.0	0.0
633	27.9	32.6	683	56.7	46.4	733	0.0	0.0
634	31.5	59.6	684	57.6	76.3	734	0.0	0.0
635	34.4	65.2	685	58.4	92.7	735	0.0	0.0
636	37.0	59.6	686	59.3	99.9	736	0.0	0.0
637	39.0	49.0	687	60.1	95.0	737	0.0	0.0
638	40.2	m	688	61.0	46.7	738	0.0	0.0

Time	Norm.	Norm.	Time	Norm.	Norm.	Time	Norm.	Norm.
s	Speed	Torque	s	Speed	Torque	s	Speed	Torque
	per cent	per cent		per cent	per cent		per cent	per cent
739	0.0	0.0	789	17.2	m	839	38.1	m
740	0.0	0.0	790	14.0	37.6	840	37.2	42.7
741	0.0	0.0	791	18.4	25.0	841	37.5	70.8
742	0.0	0.0	792	27.6	17.7	842	39.1	48.6
743	0.0	0.0	793	39.8	6.8	843	41.3	0.1
744	0.0	0.0	794	34.3	0.0	844	42.3	m
745	0.0	0.0	795	28.7	26.5	845	42.0	m
746	0.0	0.0	796	41.5	40.9	846	40.8	m
747	0.0	0.0	797	53.7	17.5	847	38.6	m
748	0.0	0.0	798	42.4	0.0	848	35.5	m
749	0.0	0.0	799	31.2	27.3	849	32.1	m
750	0.0	0.0	800	32.3	53.2	850	29.6	m
751	0.0	0.0	801	34.5	60.6	851	28.8	39.9
752	0.0	0.0	802	37.6	68.0	852	29.2	52.9
753	0.0	0.0	803	41.2	75.4	853	30.9	76.1
754	0.0	0.0	804	45.8	82.8	854	34.3	76.5
755	0.0	0.0	805	52.3	38.2	855	38.3	75.5
756	0.0	0.0	806	42.5	0.0	856	42.5	74.8
757	0.0	0.0	807	32.6	30.5	857	46.6	74.2
758	0.0	0.0	808	35.0	57.9	858	50.7	76.2
759	0.0	0.0	809	36.0	77.3	859	54.8	75.1
760	0.0	0.0	810	37.1	96.8	860	58.7	36.3
761	0.0	0.0	811	39.6	80.8	861	45.2	0.0
762	0.0	0.0	812	43.4	78.3	862	31.8	37.2
763	0.0	0.0	813	47.2	73.4	863	33.8	71.2
764	0.0	0.0	814	49.6	66.9	864	35.5	46.4
765	0.0	0.0	815	50.2	62.0	865	36.6	33.6
766	0.0	0.0	816	50.2	57.7	866	37.2	20.0
767	0.0	0.0	817	50.6	62.1	867	37.2	m
768	0.0	0.0	818	52.3	62.9	868	37.0	m
769	0.0	0.0	819	54.8	37.5	869	36.6	m
770	0.0	0.0	820	57.0	18.3	870	36.0	m
771	0.0	22.0	821	42.3	0.0	871	35.4	m
772	4.5	25.8	822	27.6	29.1	872	34.7	m
773	15.5	42.8	823	28.4	57.0	873	34.1	m
774	30.5	46.8	824	29.1	51.8	874	33.6	m
775	45.5	29.3	825	29.6	35.3	875	33.3	m
776	49.2	13.6	826	29.7	33.3	876	33.1	m
777	39.5	0.0	827	29.8	17.7	877	32.7	m
778	29.7	15.1	828	29.5	m	878	31.4	m
779	34.8	26.9	829	28.9	m	879	45.0	0.0
780	40.0	13.6	830	43.0	0.0	880	58.5	m
781	42.2	m	831	57.1	m	881	53.7	m
782	42.1	m	832	57.7	m	882	47.5	m
783	40.8	m	833	56.0	m	883	40.6	m
784	37.7	37.6	834	53.8	m	884	34.1	m
785	47.0	35.0	835	51.2	m	885	45.3	0.0
786	48.8	33.4	836	48.1	m	886	56.4	m
787	41.7	m	837	44.5	m	887	51.0	m
788	27.7	m	838	40.9	m	888	44.5	m

Time	Norm. Speed	Norm. Torque	Time	Norm. Speed	Norm. Torque	Time	Norm. Speed	Norm. Torque
s	per cent	per cent	s	per cent	per cent	s	per cent	per cent
889	36.4	m	939	32.7	56.5	989	32.6	m
890	26.6	m	940	33.4	62.8	990	30.9	m
891	20.0	m	941	34.6	68.2	991	29.9	m
892	13.3	m	942	35.8	68.6	992	29.2	m
893	6.7	m	943	38.6	65.0	993	44.1	0.0
894	0.0	0.0	944	42.3	61.9	994	59.1	m
895	0.0	0.0	945	44.1	65.3	995	56.8	m
896	0.0	0.0	946	45.3	63.2	996	53.5	m
897	0.0	0.0	947	46.5	30.6	997	47.8	m
898	0.0	0.0	948	46.7	11.1	998	41.9	m
899	0.0	0.0	949	45.9	16.1	999	35.9	m
900	0.0	0.0	950	45.6	21.8	1000	44.3	0.0
901	0.0	5.8	951	45.9	24.2	1001	52.6	m
902	2.5	27.9	952	46.5	24.7	1002	43.4	m
903	12.4	29.0	953	46.7	24.7	1003	50.6	0.0
904	19.4	30.1	954	46.8	28.2	1004	57.8	m
905	29.3	31.2	955	47.2	31.2	1005	51.6	m
906	37.1	10.4	956	47.6	29.6	1006	44.8	m
907	40.6	4.9	957	48.2	31.2	1007	48.6	0.0
908	35.8	0.0	958	48.6	33.5	1008	52.4	m
909	30.9	7.6	959	48.8	m	1009	45.4	m
910	35.4	13.8	960	47.6	m	1010	37.2	m
911	36.5	11.1	961	46.3	m	1011	26.3	m
912	40.8	48.5	962	45.2	m	1012	17.9	m
913	49.8	3.7	963	43.5	m	1013	16.2	1.9
914	41.2	0.0	964	41.4	m	1014	17.8	7.5
915	32.7	29.7	965	40.3	m	1015	25.2	18.0
916	39.4	52.1	966	39.4	m	1016	39.7	6.5
917	48.8	22.7	967	38.0	m	1017	38.6	0.0
918	41.6	0.0	968	36.3	m	1018	37.4	5.4
919	34.5	46.6	969	35.3	5.8	1019	43.4	9.7
920	39.7	84.4	970	35.4	30.2	1020	46.9	15.7
921	44.7	83.2	971	36.6	55.6	1021	52.5	13.1
922	49.5	78.9	972	38.6	48.5	1022	56.2	6.3
923	52.3	83.8	973	39.9	41.8	1023	44.0	0.0
924	53.4	77.7	974	40.3	38.2	1024	31.8	20.9
925	52.1	69.6	975	40.8	35.0	1025	38.7	36.3
926	47.9	63.6	976	41.9	32.4	1026	47.7	47.5
927	46.4	55.2	977	43.2	26.4	1027	54.5	22.0
928	46.5	53.6	978	43.5	m	1028	41.3	0.0
929	46.4	62.3	979	42.9	m	1029	28.1	26.8
930	46.1	58.2	980	41.5	m	1030	31.6	49.2
931	46.2	61.8	981	40.9	m	1031	34.5	39.5
932	47.3	62.3	982	40.5	m	1032	36.4	24.0
933	49.3	57.1	983	39.5	m	1033	36.7	m
934	52.6	58.1	984	38.3	m	1034	35.5	m
935	56.3	56.0	985	36.9	m	1035	33.8	m
936	59.9	27.2	986	35.4	m	1036	33.7	19.8
937	45.8	0.0	987	34.5	m	1037	35.3	35.1
938	31.8	28.8	988	33.9	m	1038	38.0	33.9

Time	Norm. Speed s per cent	Norm. Torque per cent	Time	Norm. Speed s per cent	Norm. Torque per cent	Time	Norm. Speed s per cent	Norm. Torque per cent
1039	40.1	34.5	1,089	46.3	24.0	1139	51.7	0.0
1040	42.2	40.4	1,090	47.8	20.6	1140	59.2	m
1041	45.2	44.0	1,091	47.2	3.8	1141	47.2	m
1042	48.3	35.9	1,092	45.6	4.4	1142	35.1	0.0
1043	50.1	29.6	1,093	44.6	4.1	1143	23.1	m
1044	52.3	38.5	1,094	44.1	m	1144	13.1	m
1045	55.3	57.7	1,095	42.9	m	1145	5.0	m
1046	57.0	50.7	1,096	40.9	m	1146	0.0	0.0
1047	57.7	25.2	1,097	39.2	m	1147	0.0	0.0
1048	42.9	0.0	1,098	37.0	m	1148	0.0	0.0
1049	28.2	15.7	1,099	35.1	2.0	1149	0.0	0.0
1050	29.2	30.5	1,100	35.6	43.3	1150	0.0	0.0
1051	31.1	52.6	1,101	38.7	47.6	1151	0.0	0.0
1052	33.4	60.7	1,102	41.3	40.4	1152	0.0	0.0
1053	35.0	61.4	1,103	42.6	45.7	1153	0.0	0.0
1054	35.3	18.2	1,104	43.9	43.3	1154	0.0	0.0
1055	35.2	14.9	1,105	46.9	41.2	1155	0.0	0.0
1056	34.9	11.7	1,106	52.4	40.1	1156	0.0	0.0
1057	34.5	12.9	1,107	56.3	39.3	1157	0.0	0.0
1058	34.1	15.5	1108	57.4	25.5	1158	0.0	0.0
1059	33.5	m	1109	57.2	25.4	1159	0.0	0.0
1060	31.8	m	1110	57.0	25.4	1160	0.0	0.0
1061	30.1	m	1111	56.8	25.3	1161	0.0	0.0
1062	29.6	10.3	1112	56.3	25.3	1162	0.0	0.0
1063	30.0	26.5	1113	55.6	25.2	1163	0.0	0.0
1064	31.0	18.8	1114	56.2	25.2	1164	0.0	0.0
1065	31.5	26.5	1115	58.0	12.4	1165	0.0	0.0
1066	31.7	m	1116	43.4	0.0	1166	0.0	0.0
1067	31.5	m	1117	28.8	26.2	1167	0.0	0.0
1068	30.6	m	1118	30.9	49.9	1168	0.0	0.0
1069	30.0	m	1119	32.3	40.5	1169	0.0	0.0
1070	30.0	m	1120	32.5	12.4	1170	0.0	0.0
1071	29.4	m	1121	32.4	12.2	1171	0.0	0.0
1072	44.3	0.0	1122	32.1	6.4	1172	0.0	0.0
1073	59.2	m	1123	31.0	12.4	1173	0.0	0.0
1074	58.3	m	1124	30.1	18.5	1174	0.0	0.0
1075	57.1	m	1125	30.4	35.6	1175	0.0	0.0
1076	55.4	m	1126	31.2	30.1	1176	0.0	0.0
1077	53.5	m	1127	31.5	30.8	1177	0.0	0.0
1078	51.5	m	1128	31.5	26.9	1178	0.0	0.0
1079	49.7	m	1129	31.7	33.9	1179	0.0	0.0
1080	47.9	m	1130	32.0	29.9	1180	0.0	0.0
1081	46.4	m	1131	32.1	m	1181	0.0	0.0
1082	45.5	m	1132	31.4	m	1182	0.0	0.0
1083	45.2	m	1133	30.3	m	1183	0.0	0.0
1084	44.3	m	1134	29.8	m	1184	0.0	0.0
1085	43.6	m	1135	44.3	0.0	1185	0.0	0.0
1086	43.1	m	1136	58.9	m	1186	0.0	0.0
1087	42.5	25.6	1137	52.1	m	1187	0.0	0.0
1088	43.3	25.7	1138	44.1	m	1188	0.0	0.0

Time	Norm. Speed	Norm. Torque	Time	Norm. Speed	Norm. Torque	Time	Norm. Speed	Norm. Torque
s	per cent	per cent	s	per cent	per cent	s	per cent	per cent
1189	0.0	0.0	1239	58.5	85.4	1289	61.9	76.1
1190	0.0	0.0	1240	59.5	85.6	1290	65.6	73.7
1191	0.0	0.0	1241	61.0	86.6	1291	69.9	79.3
1192	0.0	0.0	1242	62.6	86.8	1292	74.1	81.3
1193	0.0	0.0	1243	64.1	87.6	1293	78.3	83.2
1194	0.0	0.0	1244	65.4	87.5	1294	82.6	86.0
1195	0.0	0.0	1245	66.7	87.8	1295	87.0	89.5
1196	0.0	20.4	1246	68.1	43.5	1296	91.2	90.8
1197	12.6	41.2	1247	55.2	0.0	1297	95.3	45.9
1198	27.3	20.4	1248	42.3	37.2	1298	81.0	0.0
1199	40.4	7.6	1249	43.0	73.6	1299	66.6	38.2
1200	46.1	m	1250	43.5	65.1	1300	67.9	75.5
1201	44.6	m	1251	43.8	53.1	1301	68.4	80.5
1202	42.7	14.7	1252	43.9	54.6	1302	69.0	85.5
1203	42.9	7.3	1253	43.9	41.2	1303	70.0	85.2
1204	36.1	0.0	1254	43.8	34.8	1304	71.6	85.9
1205	29.3	15.0	1255	43.6	30.3	1305	73.3	86.2
1206	43.8	22.6	1256	43.3	21.9	1306	74.8	86.5
1207	54.9	9.9	1257	42.8	19.9	1307	76.3	42.9
1208	44.9	0.0	1258	42.3	m	1308	63.3	0.0
1209	34.9	47.4	1259	41.4	m	1309	50.4	21.2
1210	42.7	82.7	1260	40.2	m	1310	50.6	42.3
1211	52.0	81.2	1261	38.7	m	1311	50.6	53.7
1212	61.8	82.7	1262	37.1	m	1312	50.4	90.1
1213	71.3	39.1	1263	35.6	m	1313	50.5	97.1
1214	58.1	0.0	1264	34.2	m	1314	51.0	100.0
1215	44.9	42.5	1265	32.9	m	1315	51.9	100.0
1216	46.3	83.3	1266	31.8	m	1316	52.6	100.0
1217	46.8	74.1	1267	30.7	m	1317	52.8	32.4
1218	48.1	75.7	1268	29.6	m	1318	47.7	0.0
1219	50.5	75.8	1269	40.4	0.0	1319	42.6	27.4
1220	53.6	76.7	1270	51.2	m	1320	42.1	53.5
1221	56.9	77.1	1271	49.6	m	1321	41.8	44.5
1222	60.2	78.7	1272	48.0	m	1322	41.4	41.1
1223	63.7	78.0	1273	46.4	m	1323	41.0	21.0
1224	67.2	79.6	1274	45.0	m	1324	40.3	0.0
1225	70.7	80.9	1275	43.6	m	1325	39.3	1.0
1226	74.1	81.1	1276	42.3	m	1326	38.3	15.2
1227	77.5	83.6	1277	41.0	m	1327	37.6	57.8
1228	80.8	85.6	1278	39.6	m	1328	37.3	73.2
1229	84.1	81.6	1279	38.3	m	1329	37.3	59.8
1230	87.4	88.3	1280	37.1	m	1330	37.4	52.2
1231	90.5	91.9	1281	35.9	m	1331	37.4	16.9
1232	93.5	94.1	1282	34.6	m	1332	37.1	34.3
1233	96.8	96.6	1283	33.0	m	1333	36.7	51.9
1234	100.0	m	1284	31.1	m	1334	36.2	25.3
1235	96.0	m	1285	29.2	m	1335	35.6	m
1236	81.9	m	1286	43.3	0.0	1336	34.6	m
1237	68.1	m	1287	57.4	32.8	1337	33.2	m
1238	58.1	84.7	1288	59.9	65.4	1338	31.6	m

Time	Norm. Speed s per cent	Norm. Torque per cent	Time	Norm. Speed s per cent	Norm. Torque per cent	Time	Norm. Speed s per cent	Norm. Torque per cent
1339	30.1	m	1389	50.4	50.2	1439	36.3	98.8
1340	28.8	m	1390	53.0	26.1	1440	37.7	100.0
1341	28.0	29.5	1391	59.5	0.0	1441	39.2	100.0
1342	28.6	100.0	1392	66.2	38.4	1442	40.9	100.0
1343	28.8	97.3	1393	66.4	76.7	1443	42.4	99.5
1344	28.8	73.4	1394	67.6	100.0	1444	43.8	98.7
1345	29.6	56.9	1395	68.4	76.6	1445	45.4	97.3
1346	30.3	91.7	1396	68.2	47.2	1446	47.0	96.6
1347	31.0	90.5	1397	69.0	81.4	1447	47.8	96.2
1348	31.8	81.7	1398	69.7	40.6	1448	48.8	96.3
1349	32.6	79.5	1399	54.7	0.0	1449	50.5	95.1
1350	33.5	86.9	1400	39.8	19.9	1450	51.0	95.9
1351	34.6	100.0	1401	36.3	40.0	1451	52.0	94.3
1352	35.6	78.7	1402	36.7	59.4	1452	52.6	94.6
1353	36.4	50.5	1403	36.6	77.5	1453	53.0	65.5
1354	37.0	57.0	1404	36.8	94.3	1454	53.2	0.0
1355	37.3	69.1	1405	36.8	100.0	1455	53.2	m
1356	37.6	49.5	1406	36.4	100.0	1456	52.6	m
1357	37.8	44.4	1407	36.3	79.7	1457	52.1	m
1358	37.8	43.4	1408	36.7	49.5	1458	51.8	m
1359	37.8	34.8	1409	36.6	39.3	1459	51.3	m
1360	37.6	24.0	1410	37.3	62.8	1460	50.7	m
1361	37.2	m	1411	38.1	73.4	1461	50.7	m
1362	36.3	m	1412	39.0	72.9	1462	49.8	m
1363	35.1	m	1413	40.2	72.0	1463	49.4	m
1364	33.7	m	1414	41.5	71.2	1464	49.3	m
1365	32.4	m	1415	42.9	77.3	1465	49.1	m
1366	31.1	m	1416	44.4	76.6	1466	49.1	m
1367	29.9	m	1417	45.4	43.1	1467	49.1	8.3
1368	28.7	m	1418	45.3	53.9	1468	48.9	16.8
1369	29.0	58.6	1419	45.1	64.8	1469	48.8	21.3
1370	29.7	88.5	1420	46.5	74.2	1470	49.1	22.1
1371	31.0	86.3	1421	47.7	75.2	1471	49.4	26.3
1372	31.8	43.4	1422	48.1	75.5	1472	49.8	39.2
1373	31.7	m	1423	48.6	75.8	1473	50.4	83.4
1374	29.9	m	1424	48.9	76.3	1474	51.4	90.6
1375	40.2	0.0	1425	49.9	75.5	1475	52.3	93.8
1376	50.4	m	1426	50.4	75.2	1476	53.3	94.0
1377	47.9	m	1427	51.1	74.6	1477	54.2	94.1
1378	45.0	m	1428	51.9	75.0	1478	54.9	94.3
1379	43.0	m	1429	52.7	37.2	1479	55.7	94.6
1380	40.6	m	1430	41.6	0.0	1480	56.1	94.9
1381	55.5	0.0	1431	30.4	36.6	1481	56.3	86.2
1382	70.4	41.7	1432	30.5	73.2	1482	56.2	64.1
1383	73.4	83.2	1433	30.3	81.6	1483	56.0	46.1
1384	74.0	83.7	1434	30.4	89.3	1484	56.2	33.4
1385	74.9	41.7	1435	31.5	90.4	1485	56.5	23.6
1386	60.0	0.0	1436	32.7	88.5	1486	56.3	18.6
1387	45.1	41.6	1437	33.7	97.2	1487	55.7	16.2
1388	47.7	84.2	1438	35.2	99.7	1488	56.0	15.9

Time	Norm. Speed	Norm. Torque	Time	Norm. Speed	Norm. Torque	Time	Norm. Speed	Norm. Torque
s	per cent	per cent	s	per cent	per cent	s	per cent	per cent
1489	55.9	21.8	1539	57.0	59.5	1589	56.8	42.9
1490	55.8	20.9	1540	56.7	57.0	1590	56.5	42.8
1491	55.4	18.4	1541	56.7	69.8	1591	56.7	43.2
1492	55.7	25.1	1542	56.8	58.5	1592	56.5	42.8
1493	56.0	27.7	1543	56.8	47.2	1593	56.9	42.2
1494	55.8	22.4	1544	57.0	38.5	1594	56.5	43.1
1495	56.1	20.0	1545	57.0	32.8	1595	56.5	42.9
1496	55.7	17.4	1546	56.8	30.2	1596	56.7	42.7
1497	55.9	20.9	1547	57.0	27.0	1597	56.6	41.5
1498	56.0	22.9	1548	56.9	26.2	1598	56.9	41.8
1499	56.0	21.1	1549	56.7	26.2	1599	56.6	41.9
1500	55.1	19.2	1550	57.0	26.6	1600	56.7	42.6
1501	55.6	24.2	1551	56.7	27.8	1601	56.7	42.6
1502	55.4	25.6	1552	56.7	29.7	1602	56.7	41.5
1503	55.7	24.7	1553	56.8	32.1	1603	56.7	42.2
1504	55.9	24.0	1554	56.5	34.9	1604	56.5	42.2
1505	55.4	23.5	1555	56.6	34.9	1605	56.8	41.9
1506	55.7	30.9	1556	56.3	35.8	1606	56.5	42.0
1507	55.4	42.5	1557	56.6	36.6	1607	56.7	42.1
1508	55.3	25.8	1558	56.2	37.6	1608	56.4	41.9
1509	55.4	1.3	1559	56.6	38.2	1609	56.7	42.9
1510	55.0	m	1560	56.2	37.9	1610	56.7	41.8
1511	54.4	m	1561	56.6	37.5	1611	56.7	41.9
1512	54.2	m	1562	56.4	36.7	1612	56.8	42.0
1513	53.5	m	1563	56.5	34.8	1613	56.7	41.5
1514	52.4	m	1564	56.5	35.8	1614	56.6	41.9
1515	51.8	m	1565	56.5	36.2	1615	56.8	41.6
1516	50.7	m	1566	56.5	36.7	1616	56.6	41.6
1517	49.9	m	1567	56.7	37.8	1617	56.9	42.0
1518	49.1	m	1568	56.7	37.8	1618	56.7	40.7
1519	47.7	m	1569	56.6	36.6	1619	56.7	39.3
1520	47.3	m	1570	56.8	36.1	1620	56.5	41.4
1521	46.9	m	1571	56.5	36.8	1621	56.4	44.9
1522	46.9	m	1572	56.9	35.9	1622	56.8	45.2
1523	47.2	m	1573	56.7	35.0	1623	56.6	43.6
1524	47.8	m	1574	56.5	36.0	1624	56.8	42.2
1525	48.2	0.0	1575	56.4	36.5	1625	56.5	42.3
1526	48.8	23.0	1576	56.5	38.0	1626	56.5	44.4
1527	49.1	67.9	1577	56.5	39.9	1627	56.9	45.1
1528	49.4	73.7	1578	56.4	42.1	1628	56.4	45.0
1529	49.8	75.0	1579	56.5	47.0	1629	56.7	46.3
1530	50.4	75.8	1580	56.4	48.0	1630	56.7	45.5
1531	51.4	73.9	1581	56.1	49.1	1631	56.8	45.0
1532	52.3	72.2	1582	56.4	48.9	1632	56.7	44.9
1533	53.3	71.2	1583	56.4	48.2	1633	56.6	45.2
1534	54.6	71.2	1584	56.5	48.3	1634	56.8	46.0
1535	55.4	68.7	1585	56.5	47.9	1635	56.5	46.6
1536	56.7	67.0	1586	56.6	46.8	1636	56.6	48.3
1537	57.2	64.6	1587	56.6	46.2	1637	56.4	48.6
1538	57.3	61.9	1588	56.5	44.4	1638	56.6	50.3

Time	Norm.	Norm.	Time	Norm.	Norm.	Time	Norm.	Norm.
s	Speed	Torque	s	Speed	Torque	s	Speed	Torque
	per cent	per cent		per cent	per cent		per cent	per cent
1639	56.3	51.9	1689	57.6	8.9	1739	56.1	46.8
1640	56.5	54.1	1690	57.5	8.0	1740	56.1	45.8
1641	56.3	54.9	1691	57.5	5.8	1741	56.2	46.0
1642	56.4	55.0	1692	57.3	5.8	1742	56.3	45.9
1643	56.4	56.2	1693	57.6	5.5	1743	56.3	45.9
1644	56.2	58.6	1694	57.3	4.5	1744	56.2	44.6
1645	56.2	59.1	1695	57.2	3.2	1745	56.2	46.0
1646	56.2	62.5	1696	57.2	3.1	1746	56.4	46.2
1647	56.4	62.8	1697	57.3	4.9	1747	55.8	m
1648	56.0	64.7	1698	57.3	4.2	1748	55.5	m
1649	56.4	65.6	1699	56.9	5.5	1749	55.0	m
1650	56.2	67.7	1700	57.1	5.1	1750	54.1	m
1651	55.9	68.9	1701	57.0	5.2	1751	54.0	m
1652	56.1	68.9	1702	56.9	5.5	1752	53.3	m
1653	55.8	69.5	1703	56.6	5.4	1753	52.6	m
1654	56.0	69.8	1704	57.1	6.1	1754	51.8	m
1655	56.2	69.3	1705	56.7	5.7	1755	50.7	m
1656	56.2	69.8	1706	56.8	5.8	1756	49.9	m
1657	56.4	69.2	1707	57.0	6.1	1757	49.1	m
1658	56.3	68.7	1708	56.7	5.9	1758	47.7	m
1659	56.2	69.4	1709	57.0	6.6	1759	46.8	m
1660	56.2	69.5	1710	56.9	6.4	1760	45.7	m
1661	56.2	70.0	1711	56.7	6.7	1761	44.8	m
1662	56.4	69.7	1712	56.9	6.9	1762	43.9	m
1663	56.2	70.2	1713	56.8	5.6	1763	42.9	m
1664	56.4	70.5	1714	56.6	5.1	1764	41.5	m
1665	56.1	70.5	1715	56.6	6.5	1765	39.5	m
1666	56.5	69.7	1716	56.5	10.0	1766	36.7	m
1667	56.2	69.3	1717	56.6	12.4	1767	33.8	m
1668	56.5	70.9	1718	56.5	14.5	1768	31.0	m
1669	56.4	70.8	1719	56.6	16.3	1769	40.0	0.0
1670	56.3	71.1	1720	56.3	18.1	1770	49.1	m
1671	56.4	71.0	1721	56.6	20.7	1771	46.2	m
1672	56.7	68.6	1722	56.1	22.6	1772	43.1	m
1673	56.8	68.6	1723	56.3	25.8	1773	39.9	m
1674	56.6	68.0	1724	56.4	27.7	1774	36.6	m
1675	56.8	65.1	1725	56.0	29.7	1775	33.6	m
1676	56.9	60.9	1726	56.1	32.6	1776	30.5	m
1677	57.1	57.4	1727	55.9	34.9	1777	42.8	0.0
1678	57.1	54.3	1728	55.9	36.4	1778	55.2	m
1679	57.0	48.6	1729	56.0	39.2	1779	49.9	m
1680	57.4	44.1	1730	55.9	41.4	1780	44.0	m
1681	57.4	40.2	1731	55.5	44.2	1781	37.6	m
1682	57.6	36.9	1732	55.9	46.4	1782	47.2	0.0
1683	57.5	34.2	1733	55.8	48.3	1783	56.8	m
1684	57.4	31.1	1734	55.6	49.1	1784	47.5	m
1685	57.5	25.9	1735	55.8	49.3	1785	42.9	m
1686	57.5	20.7	1736	55.9	47.7	1786	31.6	m
1687	57.6	16.4	1737	55.9	47.4	1787	25.8	m
1688	57.6	12.4	1738	55.8	46.9	1788	19.9	m

Time	Norm.	Norm.	Time	Norm.	Norm.	Time	Norm.	Norm.
s	Speed	Torque	s	Speed	Torque	s	Speed	Torque
	per cent	per cent		per cent	per cent		per cent	per cent
1789	14.0	m						
1790	8.1	m						
1791	2.2	m						
1792	0.0	0.0						
1793	0.0	0.0						
1794	0.0	0.0						
1795	0.0	0.0						
1796	0.0	0.0						
1797	0.0	0.0						
1798	0.0	0.0						
1799	0.0	0.0						
1800	0.0	0.0						

m = motoring

Annex 2

A.2.1. EUROPEAN DIESEL REFERENCE FUEL

Parameter	Unit	Limits ^{1/}		Test method	
		Minimum	Maximum		
Cetene number		52	54	ISO 5165	
Density at 15 °C	kg/m ³	833	837	ISO 3675	
Distillation:					
- 50 per cent vol.	°C	245		ISO 3405	
- 95 per cent vol	°C	345	350		
- final boiling point	°C		370		
Flash point	°C	55		ISO 2719	
Cold filter plugging point	°C		-5	EN 116	
Kinematic viscosity at 40 °C	mm ² /s	2.3	3.3	ISO 3104	
Polycyclic aromatic hydrocarbons	per cent m/m	2.0	6.0	EN 12916	
Conradson carbon residue (10 per cent DR)	per cent m/m		0.2	ISO 10370	
Ash content	per cent m/m		0.01	EN-ISO 6245	
Water content	per cent m/m		0.02	EN-ISO 12937	
Sulphur content	mg/kg		10	EN-ISO 14596	
Copper corrosion at 50 °C			1	EN-ISO 2160	
Lubricity (HFRR at 60 °C)	µm		400	CEC F-06-A-96	
Neutralisation number	mg KOH/g		0.02		
Oxidation stability	mg/ml		0.025	EN-ISO 12205	

^{1/} The values quoted in the specification are "true values". In establishment of their limit values the terms of ISO 4259 "Petroleum products - Determination and application of precision data in relation to methods of test." have been applied and in fixing a minimum value, a minimum difference of 2R above zero has been taken into account; in fixing a maximum and minimum value, the minimum difference is 4R (R = reproducibility).

Notwithstanding this measure, which is necessary for statistical reasons, the manufacturer of fuels should nevertheless aim at a zero value where the stipulated maximum value is 2R and at the mean value in the case of quotations of maximum and minimum limits. Should it be necessary to clarify the question as to whether a fuel meets the requirements of the specifications, the terms of ISO 4259 should be applied.

A.2.2. UNITED STATES OF AMERICA DIESEL REFERENCE FUEL 2-D

Parameter	Unit	Test method	Limits	
			min.	max.
Cetane number	1	ASTM D 613	40	50
Cetane index	1	ASTM D 976	40	50
Density at 15 °C	kg/m ³	ASTM D 1298	840	865
Distillation		ASTM D 86		
Initial boiling point	°C		171	204
10 per cent Vol.	°C		204	238
50 per cent Vol.	°C		243	282
90 per cent Vol.	°C		293	332
Final boiling point	°C		321	366
Flash point	°C	ASTM D 93	54	-
Kinematic viscosity at 37.9 °C	mm ² /s	ASTM D 445	2	3.2
Mass fraction of sulphur	ppm	ASTM D 2785	7	15
Volume fraction of aromatics	per cent v/v	ASTM D 1319	27	-

A.2.3. JAPAN DIESEL REFERENCE FUEL

Property	Unit	Test method	Grade 1		Grade 2		Cert. Diesel	
			min.	max.	min.	max.	min.	max.
Cetane index		ISO 4264	50	-	45	-	45	-
Distillation		ISO 3405						
90 per cent Vol.	°C		-	360	-	350	-	350
Flash point	°C	ISO 3405	50	-	50	-	50	-
Cold filter plugging point	°C	ICS 75.160.20	-	-1	-	-5	-	-
Pour point	°C	ISO 3015	-	-2.5	-	-7.5	-	-
Kinematic viscosity at 30 °C	mm ² /s	ISO 2909	2.7	-	2.5	-	2.5	-
Mass fraction of sulphur	per cent	ISO 4260	-	0.005	-	0.005	-	0.005
Mass fraction of carbon residue (10 per cent bottom)	mg	ISO 4260	-	0.1	-	0.1	-	-

Annex 3

MEASUREMENT EQUIPMENT

A.3.1. Analytical system

A.3.1.1. Introduction

This annex contains general descriptions of the recommended sampling and analyzing systems. Since various configurations can produce equivalent results, exact conformance with figures 9 and 10 is not required. Components such as instruments, valves, solenoids, pumps, flow devices and switches may be used to provide additional information and coordinate the functions of the component systems. Other components which are not needed to maintain the accuracy on some systems, may be excluded if their exclusion is based upon good engineering judgement.

A.3.1.2. Description of the analytical system

Analytical system for the determination of the gaseous emissions in the raw exhaust gas (figure 9) or in the diluted exhaust gas (figure 10) are described based on the use of:

- (a) HFID or FID analyzer for the measurement of hydrocarbons;
- (b) NDIR analyzers for the measurement of carbon monoxide and carbon dioxide;
- (c) HCLD or CLD analyzer for the measurement of the oxides of nitrogen.

The sample for all components should be taken with one sampling probe and internally split to the different analyzers. Optionally, two sampling probes located in close proximity may be used. Care must be taken that no unintended condensation of exhaust components (including water and sulphuric acid) occurs at any point of the analytical system.

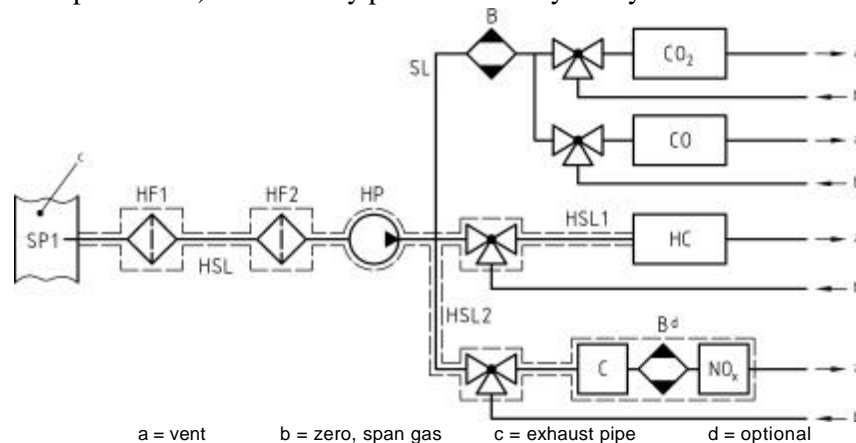

Figure 9

Schematic flow diagram of raw exhaust gas analysis system for CO, CO₂, NO_x, HC

- (d) be sufficiently distant (radially) from other probes and the tunnel wall so as to be free from the influence of any wakes or eddies
- (e) be heated so as to increase the gas stream temperature to $463 \text{ K} \pm 10 \text{ K}$ ($190 \text{ }^\circ\text{C} \pm 10 \text{ }^\circ\text{C}$) at the exit of the probe, or to $385 \text{ K} \pm 10 \text{ K}$ ($112 \text{ }^\circ\text{C} \pm 10 \text{ }^\circ\text{C}$) for positive ignition engines
- (f) non-heated in case of FID measurement (cold)

SP3 Dilute exhaust gas CO, CO₂, NO_x sampling probe (figure 10 only)

The probe shall:

- (a) be in the same plane as SP2
- (b) be sufficiently distant (radially) from other probes and the tunnel wall so as to be free from the influence of any wakes or eddies
- (c) be heated and insulated over its entire length to a minimum temperature of 328 K ($55 \text{ }^\circ\text{C}$) to prevent water condensation

HF1 Heated pre-filter (optional)

The temperature shall be the same as HSL1.

HF2 Heated filter

The filter shall extract any solid particles from the gas sample prior to the analyzer. The temperature shall be the same as HSL1. The filter shall be changed as needed.

HSL1 Heated sampling line

The sampling line provides a gas sample from a single probe to the split point(s) and the HC analyzer.

The sampling line shall:

- (a) have a 4 mm minimum and a 13.5 mm maximum inside diameter
- (b) be made of stainless steel or PTFE
- (c) maintain a wall temperature of $463 \text{ K} \pm 10 \text{ K}$ ($190 \text{ }^\circ\text{C} \pm 10 \text{ }^\circ\text{C}$) as measured at every separately controlled heated section, if the temperature of the exhaust gas at the sampling probe is equal to or below 463 K ($190 \text{ }^\circ\text{C}$)
- (d) maintain a wall temperature greater than 453 K ($180 \text{ }^\circ\text{C}$), if the temperature of the exhaust gas at the sampling probe is above 463 K ($190 \text{ }^\circ\text{C}$)
- (e) maintain a gas temperature of $463 \text{ K} \pm 10 \text{ K}$ ($190 \text{ }^\circ\text{C} \pm 10 \text{ }^\circ\text{C}$) immediately before the heated filter HF2 and the HFID

HSL2 Heated NO_x sampling line

The sampling line shall:

- (a) maintain a wall temperature of 328 K to 473 K (55 °C to 200 °C), up to the converter for dry measurement, and up to the analyzer for wet measurement
- (b) be made of stainless steel or PTFE

HP Heated sampling pump

The pump shall be heated to the temperature of HSL.

SL Sampling line for CO and CO₂

The line shall be made of PTFE or stainless steel. It may be heated or unheated.

HC HFID analyzer

Heated flame ionization detector (HFID) or flame ionization detector (FID) for the determination of the hydrocarbons. The temperature of the HFID shall be kept at 453 K to 473 K (180 °C to 200 °C).

CO, CO₂ NDIR analyzer

NDIR analyzers for the determination of carbon monoxide and carbon dioxide (optional for the determination of the dilution ratio for PT measurement).

NO_x CLD analyzer

CLD or HCLD analyzer for the determination of the oxides of nitrogen. If a HCLD is used it shall be kept at a temperature of 328 K to 473 K (55 °C to 200 °C).

B Cooling bath (optional for NO measurement)

To cool and condense water from the exhaust sample. It is optional if the analyzer is free from water vapour interference as determined in paragraph 9.3.9.2.2. If water is removed by condensation, the sample gas temperature or dew point shall be monitored either within the water trap or downstream. The sample gas temperature or dew point shall not exceed 280 K (7 °C). Chemical dryers are not allowed for removing water from the sample.

BK Background bag (optional; figure 10 only)

For the measurement of the background concentrations.

BG Sample bag (optional; figure 10 only)

For the measurement of the sample concentrations.

A.3.1.4. Non-methane cutter method (NMC)

The cutter oxidizes all hydrocarbons except CH_4 to CO_2 and H_2O , so that by passing the sample through the NMC only CH_4 is detected by the HFID. In addition to the usual HC sampling train (see figures 9 and 10), a second HC sampling train shall be installed equipped with a cutter as laid out in figure 11. This allows simultaneous measurement of total HC and NMHC.

The cutter shall be characterized at or above 600 K (327°C) prior to test work with respect to its catalytic effect on CH_4 and C_2H_6 at H_2O values representative of exhaust stream conditions.

The dew point and O_2 level of the sampled exhaust stream must be known. The relative response of the FID to CH_4 and C_2H_6 shall be determined in accordance with paragraph 9.3.8.

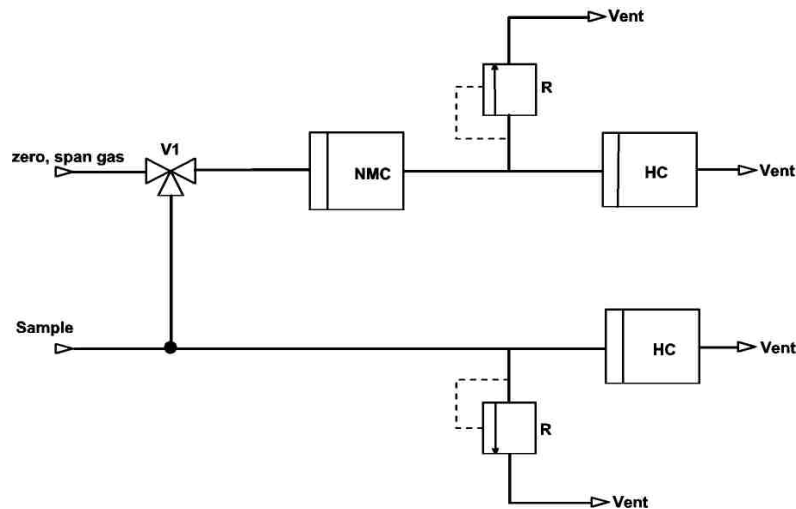

Figure 11

Schematic flow diagram of methane analysis with the NMC

A.3.1.5. Components of figure 11

NMC Non-methane cutter

To oxidize all hydrocarbons except methane

HC

Heated flame ionization detector (HFID) or flame ionization detector (FID) to measure the HC and CH₄ concentrations. The temperature of the HFID shall be kept at 453 K to 473 K (180 °C to 200 °C).

V1 Selector valve

To select zero and span gas

R Pressure regulator

To control the pressure in the sampling line and the flow to the HFID

A.3.2. Dilution and particulate sampling system

A.3.2.1. Introduction

This annex contains general descriptions of the recommended dilution and particulate sampling systems. Since various configurations can produce equivalent results, exact conformance with figures 12 to 17 is not required. Additional components such as instruments, valves, solenoids, pumps, and switches may be used to provide additional information and coordinate the functions of the component systems. Other components which are not needed to maintain the accuracy on some systems, may be excluded if their exclusion is based upon good engineering judgment.

A.3.2.2. Description of partial flow system

A dilution system is described based upon the dilution of a part of the exhaust stream. Splitting of the exhaust stream and the following dilution process may be done by different dilution system types. For subsequent collection of the particulates, the entire dilute exhaust gas or only a portion of the dilute exhaust gas is passed to the particulate sampling system. The first method is referred to as total sampling type, the second method as fractional sampling type. The calculation of the dilution ratio depends upon the type of system used.

With the total sampling system as shown in figure 12, raw exhaust gas is transferred from the exhaust pipe (EP) to the dilution tunnel (DT) through the sampling probe (SP) and the transfer tube (TT). The total flow through the tunnel is adjusted with the flow

controller FC2 and the sampling pump (P) of the particulate sampling system (see figure 16). The dilution airflow is controlled by the flow controller FC1, which may use $q_{m_{ew}}$ or $q_{m_{aw}}$ and q_{mf} as command signals, for the desired exhaust split. The sample flow into DT is the difference of the total flow and the dilution airflow. The dilution airflow rate is measured with the flow measurement device FM1, the total flow rate with the flow measurement device FM3 of the particulate sampling system (see figure 16). The dilution ratio is calculated from these two flow rates.

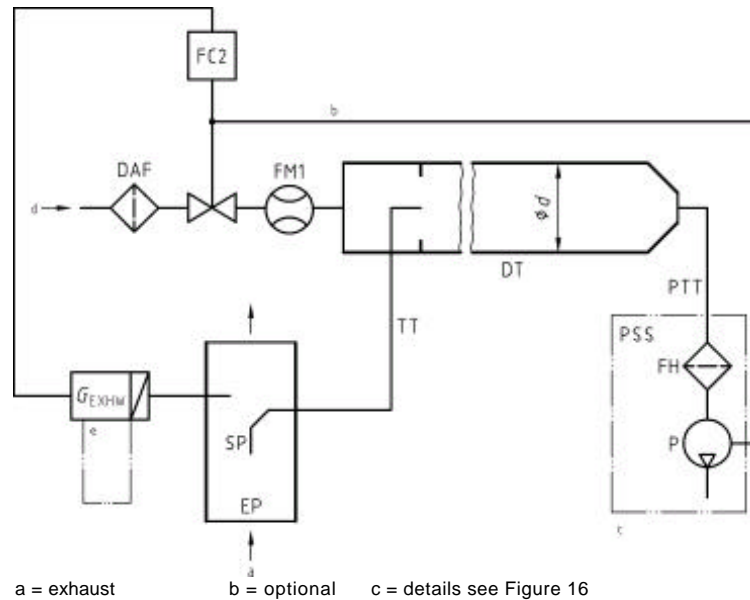

Figure 12

Scheme of partial flow dilution system (total sampling type)

With the fractional sampling system as shown in figure 13, raw exhaust gas is transferred from the exhaust pipe EP to the dilution tunnel DT through the sampling probe SP and the transfer tube TT. The total flow through the tunnel is adjusted with the flow controller FC1 connected either to the dilution airflow or to the suction blower for the total tunnel flow. The flow controller FC1 may use $q_{m_{ew}}$ or $q_{m_{aw}}$ and q_{mf} as command signals for the desired exhaust split. The sample flow into DT is the difference of the total flow and the dilution airflow. The dilution airflow rate is measured with the flow measurement device FM1, the total flow rate with the flow measurement device FM2. The dilution ratio is calculated from these two flow rates. From DT, a particulate sample is taken with the particulate sampling system (see figure 16).

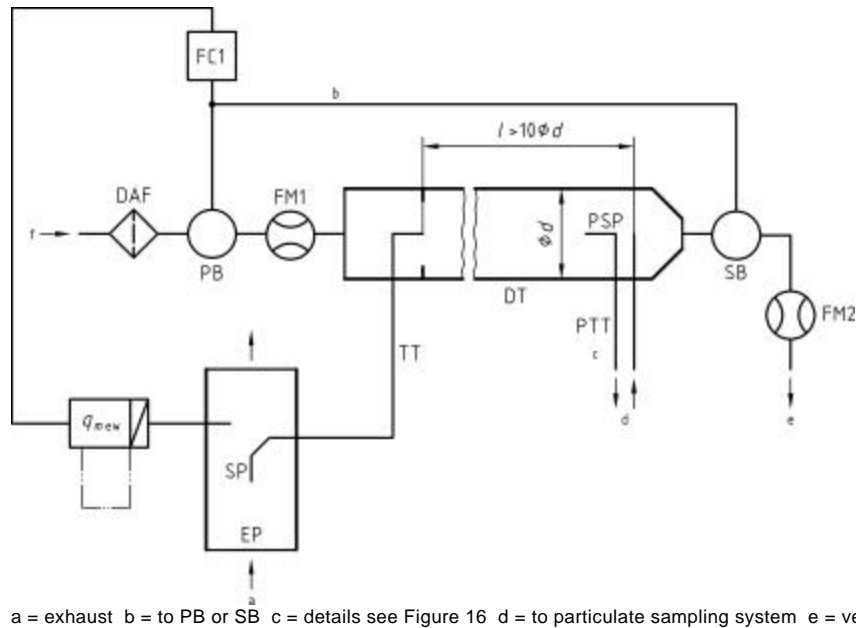

Figure 13

Scheme of partial flow dilution system (fractional sampling type)

A.3.2.3. Components of figures 12 and 13

EP Exhaust pipe

The exhaust pipe may be insulated. To reduce the thermal inertia of the exhaust pipe a thickness to diameter ratio of 0.015 or less is recommended. The use of flexible sections shall be limited to a length to diameter ratio of 12 or less. Bends shall be minimized to reduce inertial deposition. If the system includes a test bed silencer the silencer may also be insulated. It is recommended to have a straight pipe of 6 pipe diameters upstream and 3 pipe diameters downstream of the tip of the probe.

SP Sampling probe

The type of probe shall be either of the following

- open tube facing upstream on the exhaust pipe centreline
- open tube facing downstream on the exhaust pipe centreline
- multiple hole probe as described under SP in paragraph A.3.1.3.
- hatted probe facing upstream on the exhaust pipe centreline as shown in figure 14

The minimum inside diameter of the probe tip shall be 4 mm. The minimum diameter ratio between exhaust pipe and probe shall be 4.

When using probe type (a), an inertial pre-classifier (cyclone or impactor) with at 50 per cent cut point between 2.5 and 10 μm shall be installed immediately upstream of the filter holder.

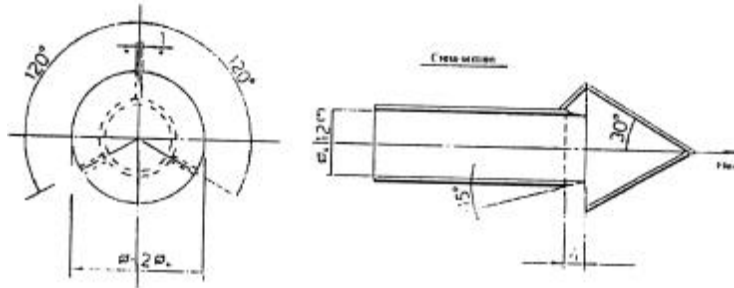

Figure 14
Scheme of hatted probe

TT Exhaust transfer tube

The transfer tube shall be:

- (a) as short as possible, but not more than 1 m in length;
- (b) equal to or greater than the probe diameter, but not more than 25 mm in diameter;
- (c) exiting on the centreline of the dilution tunnel and pointing downstream.

The tube shall be insulated with material with a maximum thermal conductivity of 0.05 W/mK with a radial insulation thickness corresponding to the diameter of the probe, or heated.

FC1 Flow controller

A flow controller shall be used to control the dilution airflow through the pressure blower PB and/or the suction blower SB. It may be connected to the exhaust flow sensor signals specified in paragraph 8.3.1. The flow controller may be installed upstream or downstream of the respective blower. When using a pressurized air supply, FC1 directly controls the airflow.

FM1 Flow measurement device

Gas meter or other flow instrumentation to measure the dilution airflow. FM1 is optional if the pressure blower PB is calibrated to measure the flow.

DAF Dilution air filter

The dilution air (ambient air, synthetic air, or nitrogen) shall be filtered with a high-efficiency (HEPA) filter that has an initial minimum collection efficiency of 99.97 per

cent. The dilution air shall have a temperature of higher than 288 K (15 °C), and may be dehumidified.

FM2 Flow measurement device (fractional sampling type, figure 13 only)

Gas meter or other flow instrumentation to measure the diluted exhaust gas flow. FM2 is optional if the suction blower SB is calibrated to measure the flow.

PB Pressure blower (fractional sampling type, figure 13 only)

To control the dilution airflow rate, PB may be connected to the flow controllers FC1 or FC2. PB is not required when using a butterfly valve. PB may be used to measure the dilution airflow, if calibrated.

SB Suction blower (fractional sampling type, figure 13 only)

SB may be used to measure the diluted exhaust gas flow, if calibrated.

DT Dilution tunnel

The dilution tunnel:

- (a) shall be of a sufficient length to cause complete mixing of the exhaust and dilution air under turbulent flow conditions for a fractional sampling system, i.e. complete mixing is not required for a total sampling system;
- (b) shall be constructed of stainless steel;
- (c) shall be at least 75 mm in diameter for the fractional sampling type;
- (d) is recommended to be at least 25 mm in diameter for the total sampling type;
- (e) may be heated to no greater than 325 K (52 °C) wall temperature;
- (f) may be insulated.

PSP Particulate sampling probe (fractional sampling type, figure 13 only)

The particulate sampling probe is the leading section of the particulate transfer tube PTT (see paragraph A.3.2.7.) and:

- (a) shall be installed facing upstream at a point where the dilution air and exhaust gas are well mixed, i.e. on the dilution tunnel DT centreline approximately 10 tunnel diameters downstream of the point where the exhaust enters the dilution tunnel;
- (b) shall be 12 mm in minimum inside diameter;
- (c) may be heated to no greater than 325 K (52 °C) wall temperature by direct heating or by dilution air pre-heating, provided the dilution air temperature does not exceed 325 K (52 °C) prior to the introduction of the exhaust into the dilution tunnel;
- (d) may be insulated.

A.3.2.4. Description of full flow dilution system

A dilution system is described based upon the dilution of the total amount of raw exhaust gas in the dilution tunnel DT using the CVS (constant volume sampling) concept, and is shown in figure 15.

The diluted exhaust gas flow rate shall be measured either with a positive displacement pump (PDP), with a critical flow venturi (CFV) or with a subsonic venturi (SSV). A heat exchanger (HE) or electronic flow compensation (EFC) may be used for proportional particulate sampling and for flow determination. Since particulate mass determination is based on the total diluted exhaust gas flow, it is not necessary to calculate the dilution ratio.

For subsequent collection of the particulates, a sample of the dilute exhaust gas shall be passed to the double dilution particulate sampling system (see figure 17). Although partly a dilution system, the double dilution system is described as a modification of a particulate sampling system, since it shares most of the parts with a typical particulate sampling system.

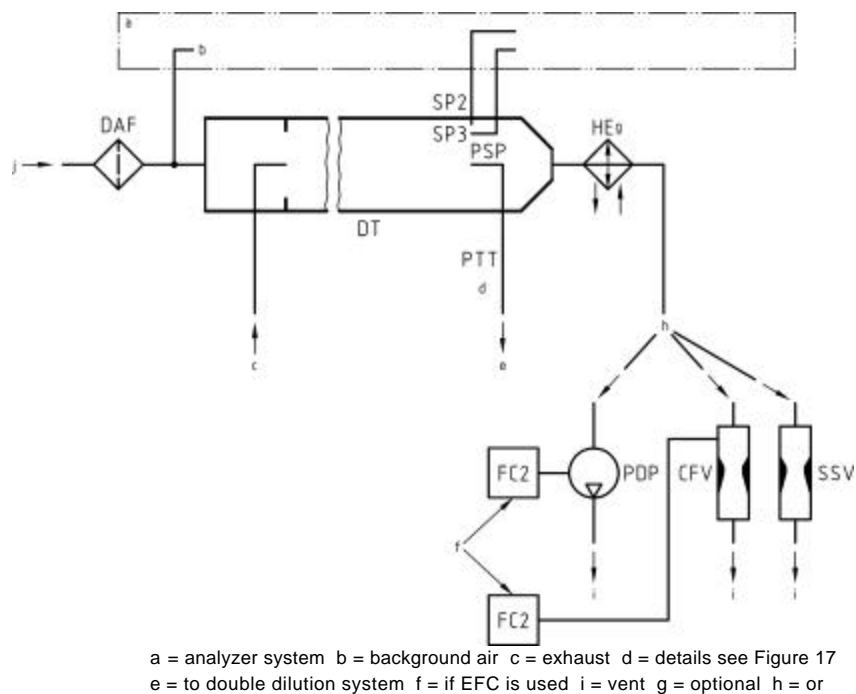

Figure 15
Scheme of full flow dilution system (CVS)

A.3.2.5. Components of figure 15

EP Exhaust pipe

The exhaust pipe length from the exit of the engine exhaust manifold, turbocharger outlet or after-treatment device to the dilution tunnel shall be not more than 10 m. If the system exceeds 4 m in length, then all tubing in excess of 4 m shall be insulated, except for an in-line smoke meter, if used. The radial thickness of the insulation shall be at least 25 mm. The thermal conductivity of the insulating material shall have a value no greater than 0.1 W/mK measured at 673 K. To reduce the thermal inertia of the exhaust pipe a thickness-to-diameter ratio of 0.015 or less is recommended. The use of flexible sections shall be limited to a length-to-diameter ratio of 12 or less.

PDP Positive displacement pump

The PDP meters total diluted exhaust flow from the number of the pump revolutions and the pump displacement. The exhaust system backpressure shall not be artificially lowered by the PDP or dilution air inlet system. Static exhaust backpressure measured with the PDP system operating shall remain within ± 1.5 kPa of the static pressure measured without connection to the PDP at identical engine speed and load. The gas mixture temperature immediately ahead of the PDP shall be within ± 6 K of the average operating temperature observed during the test, when no flow compensation (EFC) is used. Flow compensation is only permitted, if the temperature at the inlet to the PDP does not exceed 323 K (50 °C).

CFV Critical flow venturi

CFV measures total diluted exhaust flow by maintaining the flow at choked conditions (critical flow). Static exhaust backpressure measured with the CFV system operating shall remain within ± 1.5 kPa of the static pressure measured without connection to the CFV at identical engine speed and load. The gas mixture temperature immediately ahead of the CFV shall be within ± 11 K of the average operating temperature observed during the test, when no flow compensation (EFC) is used.

SSV Subsonic venturi

SSV measures total diluted exhaust flow by using the gas flow function of a subsonic venturi in dependence of inlet pressure and temperature and pressure drop between venturi inlet and throat. Static exhaust backpressure measured with the SSV system operating shall remain within ± 1.5 kPa of the static pressure measured without connection to the SSV at identical engine speed and load. The gas mixture temperature immediately ahead of the SSV shall be within ± 11 K of the average operating temperature observed during the test, when no flow compensation (EFC) is used.

HE Heat exchanger (optional)

The heat exchanger shall be of sufficient capacity to maintain the temperature within the limits required above. If EFC is used, the heat exchanger is not required.

EFC Electronic flow compensation (optional)

If the temperature at the inlet to the PDP, CFV or SSV is not kept within the limits stated above, a flow compensation system is required for continuous measurement of the flow rate and control of the proportional sampling into the double dilution system. For that purpose, the continuously measured flow rate signals are used accordingly to correct the sample flow rate through the particulate filters of the double dilution system (see figure 17).

DT Dilution tunnel

The dilution tunnel

- (a) shall be small enough in diameter to cause turbulent flow (Reynolds Number greater than 4,000) and of sufficient length to cause complete mixing of the exhaust and dilution air;
- (b) shall be at least 75 mm in diameter;
- (c) may be insulated.

The engine exhaust shall be directed downstream at the point where it is introduced into the dilution tunnel, and thoroughly mixed. A mixing orifice may be used.

When using double dilution, a sample from the dilution tunnel is transferred to the secondary dilution tunnel where it is further diluted, and then passed through the sampling filters (figure 17). The flow capacity of the PDP or CFV must be sufficient to maintain the diluted exhaust stream in the DT at a temperature of less than or equal to 464 K (191 °C) at the sampling zone. The secondary dilution system shall provide sufficient secondary dilution air to maintain the doubly diluted exhaust stream at a temperature between 315 K (42 °C) and 325 K (52 °C) immediately before the particulate filter.

DAF Dilution air filter

The dilution air (ambient air, synthetic air, or nitrogen) shall be filtered with a high-efficiency (HEPA) filter that has an initial minimum collection efficiency of 99.97 per cent. The dilution air shall have a temperature of greater than 288 K (15 °C), and may be dehumidified.

PSP Particulate sampling probe

The probe is the leading section of PTT and

- (a) shall be installed facing upstream at a point where the dilution air and exhaust gases are well mixed, i.e. on the dilution tunnel DT centreline of the dilution systems, approximately 10 tunnel diameters downstream of the point where the exhaust enters the dilution tunnel;
- (b) shall be of 12 mm minimum inside diameter;
- (c) may be heated to no greater than 325 K (52 °C) wall temperature by direct heating or by dilution air pre-heating, provided the air temperature does not exceed 325 K (52 °C) prior to the introduction of the exhaust in the dilution tunnel;
- (d) may be insulated.

A.3.2.6. Description of particulate sampling system

The particulate sampling system is required for collecting the particulates on the particulate filter and is shown in figures 16 and 17. In the case of total sampling partial flow dilution, which consists of passing the entire diluted exhaust sample through the filters, the dilution and sampling systems usually form an integral unit (see figure 12). In the case of fractional sampling partial flow dilution or full flow dilution, which consists of passing through the filters only a portion of the diluted exhaust, the dilution and sampling systems usually form different units.

For a partial flow dilution system, a sample of the diluted exhaust gas is taken from the dilution tunnel DT through the particulate sampling probe PSP and the particulate transfer tube PTT by means of the sampling pump P, as shown in figure 16. The sample is passed through the filter holder(s) FH that contain the particulate sampling filters. The sample flow rate is controlled by the flow controller FC3.

For of full flow dilution system, a double dilution particulate sampling system shall be used, as shown in figure 17. A sample of the diluted exhaust gas is transferred from the dilution tunnel DT through the particulate sampling probe PSP and the particulate transfer tube PTT to the secondary dilution tunnel SDT, where it is diluted once more. The sample is then passed through the filter holder(s) FH that contain the particulate sampling filters. The dilution airflow rate is usually constant whereas the sample flow rate is controlled by the flow controller FC3. If electronic flow compensation EFC (see figure 15) is used, the total diluted exhaust gas flow is used as command signal for FC3.

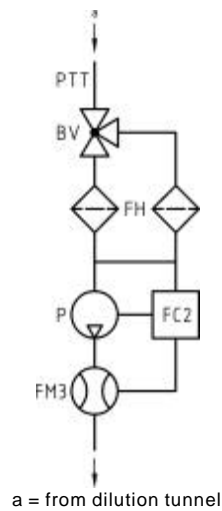

Figure 16
Scheme of particulate sampling system

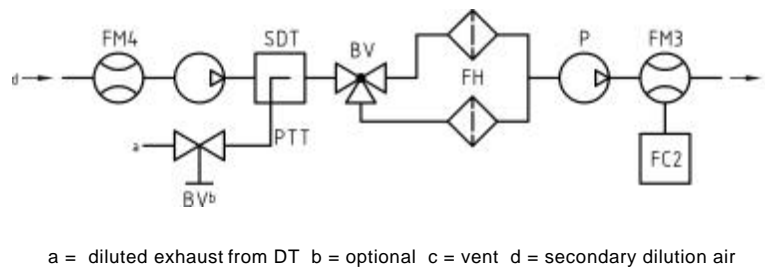

Figure 17
Scheme of double dilution particulate sampling system

A.3.2.7. Components of figures 16 (partial flow system only) and 17 (full flow system only)

PTT Particulate transfer tube

The particulate transfer tube shall not exceed 1,020 mm in length, and shall be minimized in length whenever possible.

The dimensions are valid for:

- (a) the partial flow dilution fractional sampling system from the probe tip to the filter holder;
- (b) the partial flow dilution total sampling system from the end of the dilution tunnel to the filter holder;
- (c) the full flow double dilution system from the probe tip to the entrance of the secondary dilution tunnel.

The transfer tube:

- (a) may be heated to no greater than 325 K (52°C) wall temperature;
- (b) may be insulated.

SDT Secondary dilution tunnel (figure 17 only)

The secondary dilution tunnel should have a minimum diameter of 75 mm, and should be of sufficient length so as to provide a residence time of at least 0.25 s for the doubly diluted sample. The filter holder FH shall be located within 300 mm of the exit of the SDT.

The secondary dilution tunnel:

- (a) may be heated to no greater than 325 K (52 °C) wall temperature by direct heating or by dilution air pre heating, provided the air temperature does not exceed 325 K (52°C) prior to the introduction of the exhaust into the dilution tunnel;
- (b) may be insulated.

FH Filter holder

The filter holder:

- (a) may be heated to no greater than 325 K (52 °C) wall temperature;
- (b) may be insulated.

An inertial pre-classifier with a 50 per cent cut point between 2.5 µm and 10 µm shall be installed immediately upstream of the filter holder, if an open tube sampling probe facing upstream is used.

P Sampling pump

FC2 Flow controller

A flow controller shall be used for controlling the particulate sample flow rate.

FM3 Flow measurement device

Gas meter or flow instrumentation to determine the particulate sample flow through the particulate filter. It may be installed upstream or downstream of the sampling pump P.

FM4 Flow measurement device

Gas meter or flow instrumentation to determine the secondary dilution airflow through the particulate filter.

BV Ball valve (optional)

The ball valve shall have an inside diameter not less than the inside diameter of the particulate transfer tube PTT, and a switching time of less than 0.5 s.

Annex 4

DETERMINATION OF SYSTEM EQUIVALENCE

The determination of system equivalency according to paragraph 5.1.1. shall be based on a 7 sample pair (or larger) correlation study between the candidate system and one of the accepted reference systems of this gr using the appropriate test cycle(s). The equivalency criteria to be applied shall be the F -test and the two-sided Student t -test.

This statistical method examines the hypothesis that the sample standard deviation and sample mean value for an emission measured with the candidate system do not differ from the sample standard deviation and sample mean value for that emission measured with the reference system. The hypothesis shall be tested on the basis of a 10 per cent significance level of the F and t values. The critical F and t values for 7 to 10 sample pairs are given in table 8. If the F and t values calculated according to the equation below are greater than the critical F and t values, the candidate system is not equivalent.

The following procedure shall be followed. The subscripts R and C refer to the reference and candidate system, respectively:

- (a) Conduct at least 7 tests with the candidate and reference systems operated in parallel. The number of tests is referred to as n_R and n_C .
- (b) Calculate the mean values $\overline{x_R}$ and $\overline{x_C}$ and the standard deviations s_R and s_C .
- (c) Calculate the F value, as follows:

$$F = \frac{s_{\text{major}}^2}{s_{\text{minor}}^2} \quad (82)$$

(the greater of the two standard deviations s_R or s_C must be in the numerator)

- (d) Calculate the t value, as follows:

$$t = \frac{|\overline{x_C} - \overline{x_R}|}{\sqrt{(n_C - 1) \times s_C^2 + (n_R - 1) \times s_R^2}} \times \sqrt{\frac{n_C \times n_R \times (n_C + n_R - 2)}{n_C + n_R}} \quad (83)$$

- (e) Compare the calculated F and t values with the critical F and t values corresponding to the respective number of tests indicated in table 8. If larger sample sizes are selected, consult statistical tables for 10 per cent significance (90 per cent confidence) level.
- (f) Determine the degrees of freedom (df), as follows:

$$\text{for the } F\text{-test:} \quad df = n_R - 1 / n_C - 1 \quad (84)$$

$$\text{for the } t\text{-test:} \quad df = n_C + n_R - 2 \quad (85)$$

- (g) Determine the equivalency, as follows:
- (i) if $F < F_{crit}$ and $t < t_{crit}$, then the candidate system is equivalent to the reference system of this gtr
 - (ii) if $F \geq F_{crit}$ or $t \geq t_{crit}$, then the candidate system is different from the reference system of this gtr

Sample Size	<i>F</i> -test		<i>t</i> -test	
	<i>df</i>	F_{crit}	<i>df</i>	t_{crit}
7	6/6	3.055	12	1.782
8	7/7	2.785	14	1.761
9	8/8	2.589	16	1.746
10	9/9	2.440	18	1.734

Table 8
t and *F* values for selected sample sizes

Annex 5

CARBON FLOW CHECK

A.5.1. Introduction

All but a tiny part of the carbon in the exhaust comes from the fuel, and all but a minimal part of this is manifest in the exhaust gas as CO₂. This is the basis for a system verification check based on CO₂ measurements.

The flow of carbon into the exhaust measurement systems is determined from the fuel flow rate. The flow of carbon at various sampling points in the emissions and particulate sampling systems is determined from the CO₂ concentrations and gas flow rates at those points.

In this sense, the engine provides a known source of carbon flow, and observing the same carbon flow in the exhaust pipe and at the outlet of the partial flow PM sampling system verifies leak integrity and flow measurement accuracy. This check has the advantage that the components are operating under actual engine test conditions of temperature and flow.

Figure 18 shows the sampling points at which the carbon flows shall be checked. The specific equations for the carbon flows at each of the sample points are given below.

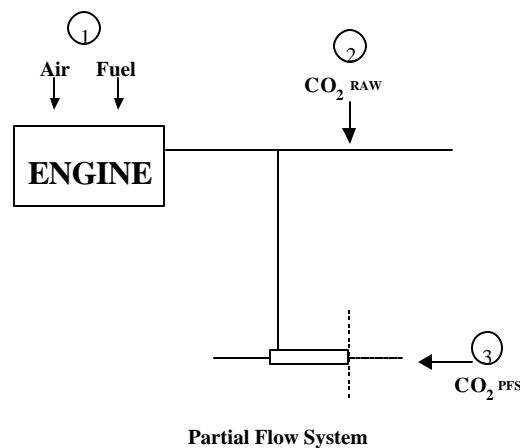

Figure 18
Measuring points for carbon flow check

A.5.2. Carbon flow rate into the engine (location 1)

The carbon mass flow rate into the engine for a fuel $C_bH_aO_e$ is given by:

$$q_{mCf} = \frac{12\beta}{12\beta + a + 16e} \times q_{mf} \quad (86)$$

where:

q_{mf} is the fuel mass flow rate, kg/s

A.5.3. Carbon flow rate in the raw exhaust (location 2)

The carbon mass flow rate in the exhaust pipe of the engine shall be determined from the raw CO_2 concentration and the exhaust gas mass flow rate:

$$q_{mCe} = \left(\frac{c_{CO2r} - c_{CO2a}}{100} \right) \times q_{mew} \times \frac{12.011}{M_e} \quad (87)$$

where:

$c_{CO2,r}$ is the wet CO_2 concentration in the raw exhaust gas, per cent

$c_{CO2,a}$ is the wet CO_2 concentration in the ambient air, per cent

q_{mew} is the exhaust gas mass flow rate on wet basis, kg/s

M_e is the molar mass of exhaust gas, g/mol

If CO_2 is measured on a dry basis it shall be converted to a wet basis according to paragraph 8.1.

A.5.4. Carbon flow rate in the dilution system (location 3)

For the partial flow dilution system, the splitting ratio also needs to be taken into account. The carbon flow rate shall be determined from the dilute CO_2 concentration, the exhaust gas mass flow rate and the sample flow rate:

$$q_{mCp} = \left(\frac{c_{CO2d} - c_{CO2a}}{100} \right) \times q_{mdew} \times \frac{12.011}{M_e} \times \frac{q_{mew}}{q_{mp}} \quad (88)$$

where:

$c_{CO2,d}$ is the wet CO_2 concentration in the dilute exhaust gas at the outlet of the dilution tunnel, per cent

$c_{CO2,a}$ is the wet CO_2 concentration in the ambient air, per cent

q_{mew} is the exhaust gas mass flow rate on wet basis, kg/s

q_{mp} is the sample flow of exhaust gas into partial flow dilution system, kg/s

M_e is the molar mass of exhaust gas, g/mol

If CO₂ is measured on a dry basis, it shall be converted to wet basis according to paragraph 8.1.

A.5.5. Calculation of the molar mass of the exhaust gas

The molar mass of the exhaust gas shall be calculated according to equation 30 (see paragraph 8.3.2.5.)

Alternatively, the following exhaust gas molar masses may be used:

$$M_e \text{ (diesel)} = 28.9 \text{ g/mol}$$

$$M_e \text{ (LPG)} = 28.6 \text{ g/mol}$$

$$M_e \text{ (NG)} = 28.3 \text{ g/mol}$$

Annex 6

EXAMPLE OF CALCULATION PROCEDURE

A.6.1. Basic data for stoichiometric calculations

Atomic mass of hydrogen	1.00794 g/atom
Atomic mass of carbon	12.011 g/atom
Atomic mass of sulphur	32.065 g/atom
Atomic mass of nitrogen	14.0067 g/atom
Atomic mass of oxygen	15.9994 g/atom
Atomic mass of argon	39.9 g/atom
Molar mass of water	18.01534 g/mol
Molar mass of carbon dioxide	44.01 g/mol
Molar mass of carbon monoxide	28.011 g/mol
Molar mass of oxygen	31.9988 g/mol
Molar mass of nitrogen	28.011 g/mol
Molar mass of nitric oxide	30.008 g/mol
Molar mass of nitrogen dioxide	46.01 g/mol
Molar mass of sulphur dioxide	64.066 g/mol
Molar mass of dry air	28.965 g/mol

Assuming no compressibility effects, all gases involved in the engine intake/combustion/exhaust process can be considered to be ideal and any volumetric calculations shall therefore be based on a molar volume of 22.414 l/mol according to Avogadro's hypothesis.

A.6.2. Gaseous emissions (diesel fuel)

The measurement data of an individual point of the test cycle (data sampling rate of 1 Hz) for the calculation of the instantaneous mass emission are shown below. In this example, CO and NO_x are measured on a dry basis, HC on a wet basis. The HC concentration is given in propane equivalent (C3) and has to be multiplied by 3 to result in the C1 equivalent. The calculation procedure is identical for the other points of the cycle.

The calculation example shows the rounded intermediate results of the different steps for better illustration. It should be noted that for actual calculation, rounding of intermediate results is not permitted (see paragraph 8).

$T_{a,i}$ (K)	$H_{a,i}$ (g/kg)	W_{act} kWh	$q_{mew,i}$ (kg/s)	$q_{maw,i}$ (kg/s)	$q_{mf,i}$ (kg/s)	$c_{HC,i}$ (ppm)	$c_{CO,i}$ (ppm)	$c_{NOx,i}$ (ppm)
295	8.0	40	0.155	0.150	0.005	10	40	500

The following fuel composition is considered:

Component	Molar ratio	per cent mass
H	a = 1.8529	$w_{ALF} = 13.45$
C	b = 1.0000	$w_{BET} = 86.50$
S	g = 0.0002	$w_{GAM} = 0.050$
N	d = 0.0000	$w_{DEL} = 0.000$
O	e = 0.0000	$w_{EPS} = 0.000$

Step 1: Dry/wet correction (paragraph 8.1.):

$$\text{Equation (11): } k_f = 0.055584 \times 13.45 - 0.0001083 \times 86.5 - 0.0001562 \times 0.05 = 0.7382$$

$$\text{Equation (8): } k_{w,a} = \left(1 - \frac{1.2434 \times 8 + 111.12 \times 13.45 \times \frac{0.005}{0.148}}{773.4 + 1.2434 \times 8 + \frac{0.005}{0.148} \times 0.7382 \times 1,000} \right) \times 1.008 = 0.9331$$

$$\begin{aligned} \text{Equation (7): } c_{CO,i} \text{ (wet)} &= 40 \times 0.9331 &&= 37.3 \text{ ppm} \\ c_{NOx,i} \text{ (wet)} &= 500 \times 0.9331 &&= 466.6 \text{ ppm} \end{aligned}$$

Step 2: NO_x correction for temperature and humidity (paragraph 8.2.1.):

$$\text{Equation (18): } k_{h,D} = \frac{15.698 \times 8.00}{1,000} + 0.832 = 0.9576$$

Step 3: Calculation of the instantaneous emission of each individual point of the cycle (paragraph 8.3.2.4.):

$$\begin{aligned} \text{Equation (25): } m_{HC,i} &= 10 \times 3 \times 0.155 &&= 4.650 \\ m_{CO,i} &= 37.3 \times 0.155 &&= 5.782 \\ m_{NOx,i} &= 466.6 \times 0.9576 \times 0.155 &&= 69.26 \end{aligned}$$

Step 4: Calculation of the mass emission over the cycle by integration of the instantaneous emission values and the u values from table 4 (paragraph 8.3.2.4.):

The following calculation is assumed for the WHTC cycle (1,800 s) and the same emission in each point of the cycle.

$$\begin{aligned} \text{Equation (25): } m_{HC} &= 0.000479 \times \sum_{i=1}^{1800} 4.650 &&= 4.01 \text{ g/test} \\ m_{CO} &= 0.000966 \times \sum_{i=1}^{1800} 5.782 &&= 10.05 \text{ g/test} \end{aligned}$$

$$m_{\text{NOx}} = 0.001586 \times \sum_{i=1}^{1800} 69.26 = 197.72 \text{ g/test}$$

Step 5: Calculation of the specific emissions (paragraph 8.5.2.1.):

$$\begin{aligned} \text{Equation (56): } e_{\text{HC}} &= 4.01 / 40 &&= 0.10 \text{ g/kWh} \\ e_{\text{CO}} &= 10.05 / 40 &&= 0.25 \text{ g/kWh} \\ e_{\text{NOx}} &= 197.72 / 40 &&= 4.94 \text{ g/kWh} \end{aligned}$$

A.6.2. Particulate Emission (Diesel Fuel)

P_b (kPa)	W_{act} (kWh)	$q_{m_{\text{ew},i}}$ (kg/s)	$q_{m_{\text{fi}}}$ (kg/s)	$q_{m_{\text{dw},i}}$ (kg/s)	$q_{m_{\text{dew},i}}$ (kg/s)	m_{uncor} (mg)	m_{sep} (kg)
99	40	0.155	0.005	0.0015	0.0020	1.7000	1.515

Step 1: Calculation of m_{edf} (paragraph 8.3.3.5.2.):

$$\text{Equation (37): } r_{\text{d},i} = \frac{0.002}{(0.002 - 0.0015)} = 4$$

$$\text{Equation (36): } q_{m_{\text{edf},i}} = 0.155 \times 4 = 0.620 \text{ kg/s}$$

$$\text{Equation (35): } m_{\text{edf}} = \sum_{i=1}^{1800} 0.620 = 1,116 \text{ kg/test}$$

Step 2: Buoyancy correction of the particulate mass (paragraph 9.4.3.5.)

$$\text{Equation (72): } \rho_a = \frac{99 \times 28.836}{8.3144 \times 295} = 1.164 \text{ kg/m}^3$$

$$\text{Equation (71): } m_f = 1.7000 \times \frac{(1 - 1.164/8,000)}{(1 - 1.164/2,300)} = 1.7006 \text{ mg}$$

Step 3: Calculation of the particulate mass emission (paragraph 8.3.3.5.2.):

$$\text{Equation (34): } m_{\text{PM}} = \frac{1.7006}{1.515} \times \frac{1,116}{1,000} = 1.253 \text{ g/test}$$

Step 4: Calculation of the specific emission (paragraph 8.5.2.1.):

$$\text{Equation (56): } e_{\text{PM}} = 1.253 / 40 = 0.031 \text{ g/kWh}$$
