

E/ECE/324 }
E/ECE/TRANS/505 } Rev.1/Add.36/Rev.3/Amend.3

8 April 2004

AGREEMENT

CONCERNING THE ADOPTION OF UNIFORM TECHNICAL PRESCRIPTIONS FOR WHEELED VEHICLES, EQUIPMENT AND PARTS WHICH CAN BE FITTED AND/OR BE USED ON WHEELED VEHICLES AND THE CONDITIONS FOR RECIPROCAL RECOGNITION OF APPROVALS GRANTED ON THE BASIS OF THESE PRESCRIPTIONS */

(Revision 2, including the amendments which entered into force on 16 October 1995)

Addendum 36: Regulation No. 37

Revision 3 - Amendment 3

Supplement 23 to the 03 series of amendments - Date of entry into force: 26 February 2004

UNIFORM PROVISIONS CONCERNING THE APPROVAL OF FILAMENT LAMPS FOR USE IN APPROVED LAMP UNITS OF POWER-DRIVEN VEHICLES AND OF THEIR TRAILERS



UNITED NATIONS

*/ Former title of the Agreement:

Agreement Concerning the Adoption of Uniform Conditions of Approval and Reciprocal Recognition of Approval for Motor Vehicle Equipment and Parts, done at Geneva on 20 March 1958.

GE.04-21505

List of contents,

ANNEXES, amend the list, to read (deleting the details listed for Annex 1): */

"Annex 1: Sheets for filament lamps
Annex 2 Communication"
....."

Text of the Regulation,

Paragraph 2.3.1.4., amend to read:

"2.3.1.4. the rated wattage (in the sequence, high wattage/ low wattage filament for dual-filament lamps); this need not be"

Paragraph 3.1.5., amend to read:

"3.1.5. Standard (étalon) filament lamp: a filament lamp emitting white or amber or red light with reduced dimensional tolerances, used for the photometric testing of lighting"

Paragraph 3.6.2., amend to read:

".....
finished filament lamps emitting amber light:

limit towards green: $y = x - 0.120$
limit towards red: $y = 0.390$
limit towards white: $y = 0.790 - 0.670 x$;

finished filament lamps emitting red light:

limit towards yellow: $y = 0.335$
limit towards purple: $y = 0.980 - x$ "

Paragraph 3.6.3., amend to read:

"..... a point of choice on the Planckian locus (IEC Publication 15.2 Colorimetry, 1986). Filament lamps for use in light signalling devices shall meet the requirements as specified in paragraph 2.4.2 of IEC Publication 60809, Amendment 3 to Edition 2."

*/ This amendment shall only be carried out when Revision 4 of Regulation No. 37 will be prepared.

Footnote 5/, (pertinent to para. 3.6.3.), amend to read:

"5/ For Conformity of Production purposes and for amber and red colour only, at least 80 per cent of the measuring results shall lie within the required tolerance area."

Paragraph 3.10., amend to read:

"..... in the x and/or y direction.

For standard (étalon) filament lamps emitting amber or red light, changes of the bulb temperature shall not affect the luminous flux, which might impair photometric measurements of signalling devices. Moreover, for amber standard (étalon) filament lamps the colour shall be in the lower part of the tolerance area."

Annex 1, make the following corrections and amendments:

Sheet R2/1, delete the title of "Annex 1" from the sheet.

Sheet H3/3, the table, the cap designation "PK 22s", correct to read "PK22s".

Sheet H4/2, the table, the cap designation "P43 t", correct to read "P43t".

Sheet P21/4W/1, the table,

Dimension "e", for "Filament lamps of normal production", nominal values of dimensions ("nom."), correct the reference to the footnote, to read "31.8 1";

The cap designation "BAZ 15s", correct to read "BAZ15s";

Footnote 1/, amend the reference to the footnote to read: "... of a "Box-System" 3/ based ..."; and

Footnote "*/" renumber as footnote "3", to read: "3 The "Box-System" is the same"

Sheet P21/5W/1, the table, "Rated values, Volts", for "Standard filament lamp" insert the missing value of "12".

Sheet C5W/1, the table, the cap designation "SV 8.5", correct to read "SV8.5".

Sheet C21W/1, the table, the cap designation "SV 8.5", correct to read: "SV8.5".

Sheet T4W/1, the table,

The IEC Publication sheet number, amend to read "(sheet 7004-14-8)"; and

The cap designation "BA 9s", correct to read "BA9s".

Sheet S1/S2/2, the table, the cap designation "BA 20d", correct to read "BA20d".

Sheet HS1/2, the table, the cap designation "PX43 t", correct to read "PX43t".

Sheet HS2/2, the table, the cap designation "PX 13.5s", correct to read "PX13.5s".

Sheet PY21W/1, the table,

The cap designation "BAU 15s", correct to read: "BAU15s";

The words "Clear bulb" and "Amber bulb", amend to read "White" and "Amber", respectively, and

Footnote 4/, amend to read:

"4/ The light emitted from standard filament lamps shall be amber or white."

Sheet H6W/1, the table, the cap designation "BAX 9s", correct to read "BAX9s".

Sheet HB3/3, the table, the cap designation "P20 d", correct to read "P20d".

Sheet H7/3, the table,

The IEC Publication sheet number, amend to read "(sheet 7004-5-5)", and

The cap designation "PX 26d", correct to read "PX26d".

Sheets H27W/2 and H27W/3,

The title, correct to read: "CATEGORIES H27W/1 AND H27W/2", and

Sheet H27W/2, the table, the cap designation "PGJ 13", correct to read: "PGJ13".

Sheet W21W/1, the table, the IEC Publication sheet number, amend to read "(sheet 7004-105-2)".

Sheet W21/5W/1, the table, the IEC Publication sheet number, amend to read "(sheet 7004 106-2)".

Sheet HIR1/2, the table, the cap designation "PX20 d", correct to read "PX20d".

Sheet P27/7W/1, footnote 3/, amend to read: "... sheets P27/7W/2 and 3."

Sheet WY21W/1, the table,

The words "Clear bulb" and "Amber bulb", amend to read "White" and "Amber", respectively, and

Footnote 4/, amend to read:

"4/ The light emitted from standard filament lamps shall be amber or white."

Sheet WY2.3W/1, the table,

The words "Clear bulb" and "Amber bulb", amend to read "White" and "Amber", respectively, and

Footnote 3/, amend to read:

"3/ The light emitted from standard filament lamps shall be amber or white."

Sheet H13/4, the table, the cap designations, amend to read "H13: P26.4t" and "H13A: PJ26.4t".

Sheet WP21W/1, the table,

The words "Clear bulb" and "Amber bulb", amend to read "White" and "Amber", respectively;

Footnote 4/, amend to read:

"4/ The light emitted from filament lamps of normal production shall be white for category WP21W and amber for category WPY21W. (See also footnote 5/).", and

Add footnote 5/, to read:

"5/ The light emitted from standard filament lamps shall be white for category WP21W and white or amber for category WPY21W."

Annex 1, delete, replace or insert the following sheets (see the next pages):

Sheet P21W/2, replace by the new sheet P21W/2.

Sheet PY21W/2, should be deleted.

Sheet R5W/1, replace by the new sheet R5W/1 (Category R5W and RR5W).

Sheet R10W/1, replace by the new sheet R10W/1 (Category R10W, RY10W and RR10W).

Sheet W5W/1, replace by the new sheet W5W/1 (Category W5W, WY5W and WR5W).

Sheet PY27/7W/1, replace by the new sheet PY27/7W/1.

Sheets P19W/1 to P19W/3, replace by the new sheets P19W/1 to P19W/3 (Category P19W, PY19W, PR19W, PS19W, PSY19W, PSR19W).

Sheets P24W/1 to P24W/3, replace by the new sheets P24W/1 to P24W/3 (Category P24W, PY24W, PR24W, PS24W, PSY24W, PSR24W).

Add at the end new sheets PR21W/1, PR21/4W/1, PR21/5W/1 and PR27/7W/1.

Add at the end new sheets HS5/1 to HS5/4.

Annex 1, insert new pages at the beginning of the annex, to read (see next pages), and re-arrange the sequence of the sheets in the order of the sheet numbers, as indicated in the "List of sheets for filament lamps and their sequence". */

Annex 2, item 9, amend to read:

" Colour of the light emitted: White/selective-yellow/amber/red 2/"

*/ This amendment shall only be carried out when Revision 4 of Regulation No. 37 will be prepared.

Annex 1

SHEETS */ FOR FILAMENT LAMPS

List of categories of filament lamps and their sheet numbers:

Category	Sheet number(s)
H1	H1/1 to 3
H3	H3/1 to 4
H4	H4/1 to 5
H7	H7/1 to 4
H8	H8/1 to 4
H8A	H8/1 to 4
H9	H9/1 to 4
H9A	H9/1 to 4
H10	H10/1 to 3
H11	H11/1 to 4
H11A	H11/1 to 4
H12	H12/1 to 3
H13	H13/1 to 4
H13A	H13/1 to 4
H14	H14/1 to 4
H27W/1	H27W/1 to 3
H27W/2	H27W/1 to 3
HB3	HB3/1 to 4
HB3A	HB3/1 to 4
HB4	HB4/1 to 4
HB4A	HB4/1 to 4
HIR1	HIR1/1 to 3
HIR2	HIR2/1 to 3
HS1	HS1/1 to 5
HS2	HS2/1 to 3
HS5	HS5/1 to 4
R2	R2/1 to 3
S1	S1/S2/1 to 2
S2	S1/S2/1 to 2
S3	S3/1

*/ Tables, Electrical and Photometric characteristics:
 Voltage is expressed in Volts (V);
 Wattage is expressed in Watts (W);
 Luminous flux is expressed in lumens (lm).

Category	Sheet number(s)
only for signalling lamps:	
C5W	C5W/1
C21W	C21W/1 to 2
H6W	H6W/1
H21W	H21W/1 to 2
P19W	P19W/1 to 3
P21W	P21W/1 to 2
P21/4W	P21/4W/1 (P21/5W/2 to 3)
P21/5W	P21/5W/1 to 3
P24W	P24W/1 to 3
P27W	P27W/1 to 2
P27/7W	P27/7W/1 to 3
PR19W <u>**/</u>	P19W/1 to 3
PR21W <u>**/</u>	PR21W/1 (P21W/2)
PR21/4W <u>**/</u>	PR21/4W/1 (P21/5W/2 to 3)
PR21/5W <u>**/</u>	PR21/5W/1 (P21/5W/2 to 3)
PR24W <u>**/</u>	P24W/1 to 3
PR27/7W <u>**/</u>	PR27/7W/1 (P27/7W/2 to 3)
PS19W	P19W/1 to 3
PS24W	P24W/1 to 3
PSR19W <u>**/</u>	P19W/1 to 3
PSR24W <u>**/</u>	P24W/1 to 3
PSY19W	P19W/1 to 3
PSY24W	P24W/1 to 3
PY19W	P19W/1 to 3
PY21W	PY21W/1 (P21W/2)
PY24W	P24W/1 to 3
PY27/7W	PY27/7W/1 (P27/7W/2 to 3)
R5W	R5W/1
R10W	R10W/1
RR5W <u>**/</u>	R5W/1
RR10W <u>**/</u>	R10W/1
RY10W	R10W/1
T1.4W	T1.4W/1
T4W	T4W/1
W2.3W	W2.3W/1
W3W	W3W/1
W5W	W5W/1

**/ Not for use in stop-lamps.

Category	Sheet number(s)
W16W	W16W/1
W21W	W21W/1 to 2
W21/5W	W21/5W/1 to 3
WP21W	WP21W/1 to 2
WPY21W	WP21W/1 to 2
WR5W <u>**/</u>	W5W/1
WY2.3W	WY2.3W/1
WY5W	W5W/1
WY21W	WY21W/1 to 2

**/ Not for use in stop-lamps.

* * *

List of sheets for filament lamps and their sequence in this annex:

Sheet number(s)
C5W/1
C21W/1 to 2
H1/1 to 3
H3/1 to 4
H4/1 to 5
H7/1 to 4
H8/1 to 4
H9/1 to 4
H10/1 to 3
H11/1 to 4
H12/1 to 3
H13/1 to 4
H14/1 to 4
H6W/1
H21W/1 to 2
H27W/1 to 3
HB3/1 to 4
HB4/1 to 4
HIR1/1 to 3
HIR2/1 to 3
HS1/1 to 5
HS2/1 to 3
HS5/1 to 4
P19W/1 to 3

Sheet number(s)

P21W/1 to 2
P21/4W/1
P21/5W/1 to 3
P24W/1 to 3
P27W/1 to 2
P27/7W/1 to 3
PR21W/1
PR21/4W/1
PR21/5W/1
PR27/7W/1
PY21W/1
PY27/7W/1
R2/1 to 3
R5W/1
R10W/1
S1/S2/1 to 2
S3/1
T1.4W/1
T4W/1
W2.3W/1
W3W/1
W5W/1
W16W/1
W21W/1 to 2
W21/5W/1 to 3
WP21W/1 to 2
WY2.3W/1
WY21W/1 to 2

Screen projection requirements

This test is used to determine, by checking whether the filament is correctly positioned relative to the reference axis and reference plane and has an axis perpendicular, within $\pm 15^\circ$, to the plane through the centre line of the pins (P21W) or of the reference pin (PY21W and PR21W) and the reference axis, whether a filament lamp complies with the requirements.

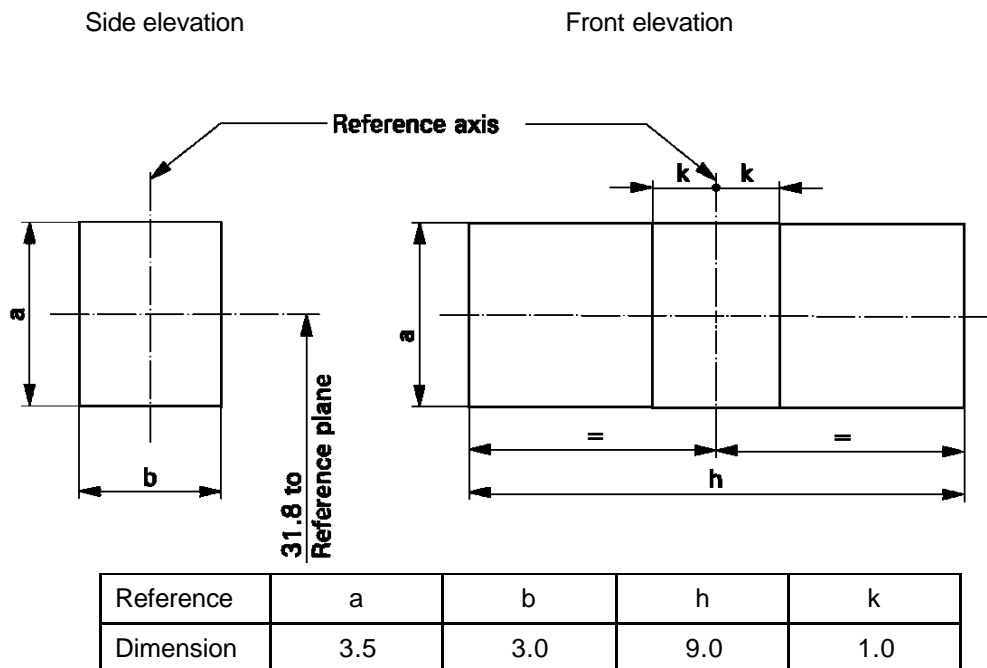

Test procedures and requirements.

1. The filament lamp is placed in a holder capable of being rotated about its axis and having either a calibrated scale or fixed stops corresponding to the angular displacement tolerance limits. The holder is then so rotated that an end view of the filament is seen on the screen on to which the image of the filament is projected. The end view of the filament shall be obtained within the angular displacements tolerance limits.
2. Side elevation
 The filament lamp placed with the cap down, the reference axis vertical and the filament seen end-on, the projection of the filament shall lie entirely within a rectangle of height "a" and width "b", having its centre at the theoretical position of the centre of the filament.
3. Front elevation
 The filament lamp placed with the cap down and the reference axis vertical, the filament lamp being viewed in a direction at right angles to the filament axis:
 - 3.1. The projection of the filament shall lie entirely within a rectangle of height "a" and width "h", having its centre at the theoretical position of the centre of the filament.
 - 3.2. The centre of the filament shall not be offset by more than distance "k" from the reference axis.

CATEGORY R5W and RR5W

Sheet R5W/1

The drawings are intended only to illustrate the essential dimensions (in mm) of the filament lamp

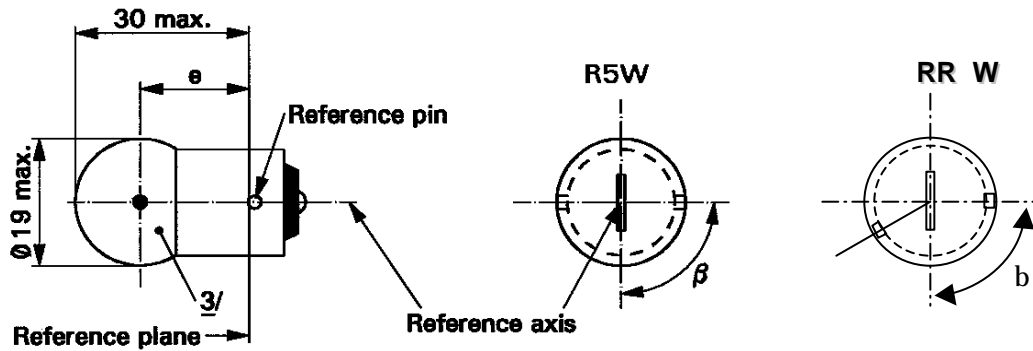

Dimensions in mm	Filament lamps of normal production			Standard filament lamp	
	min.	nom.	max.	4/	
e	17.5	19.0	20.5	19.0 ± 0.3	
Lateral deviation 2/			1.5	0.3 max.	
β	60°	90°	120°	90° ± 5°	
Cap:	R5W: BA15s RR5W: BAW15s	in accordance with IEC Publication 60061		(sheet 7004-11A-9) 1/ (sheet 7004-11E-1)	
ELECTRICAL AND PHOTOMETRIC CHARACTERISTICS					
Rated values	Volts	6 5/	12	24	12
	Watts	5			5
Test voltage	Volts	6.75	13.5	28.0	13.5
Objective values	Watts	5.5 max.		7.7 max.	5.5 max.
	Luminous flux	R5W	50 ± 20 %		
		RR5W	5/	12 ± 25 %	
Reference luminous flux at approximately 13.5 V:		White: 50 lm Red: 12 lm			

- 1/ Filament lamps with cap BA15d may be used for special purposes; they have the same dimensions.
- 2/ Maximum lateral deviation of filament centre from two mutually perpendicular planes both containing the reference axis and one containing the axis of the reference pin.
- 3/ The light emitted from filament lamps of normal production shall be white for category R5W and red for category RR5W. (See also note 4/.)
- 4/ The light emitted from standard filament lamps shall be white for category R5W; white or red for category RR5W.
- 5/ Within RR5W no 6 V rated voltage type specified.

CATEGORIES R10W, RY10W AND RR10W

Sheet R10W/1

The drawings are intended only to illustrate the essential dimensions (in mm) of the filament lamp

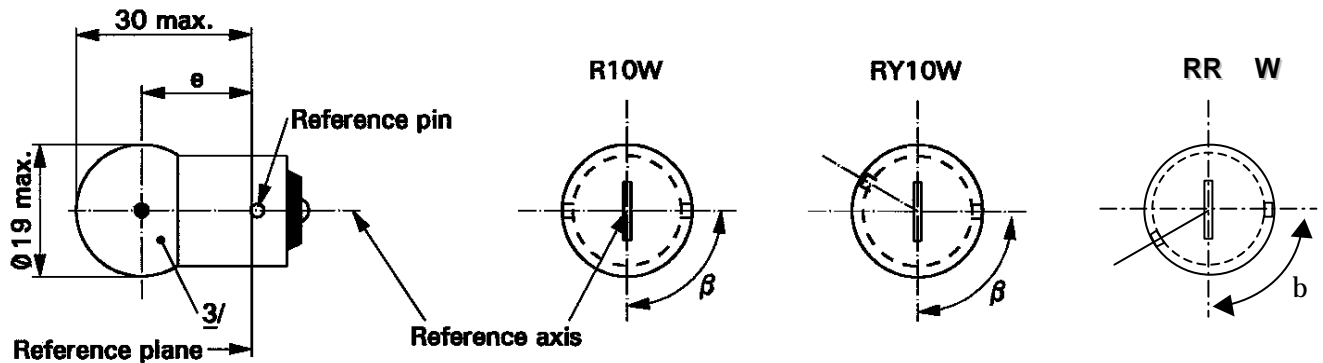

Dimensions in mm		Filament lamps of normal production			Standard filament lamp	
		min.	nom.	max.	4/	
E		17.5	19.0	20.5	19.0 ± 0.3	
Lateral deviation 2/				1.5	0.3 max.	
β		60°	90°	120°	90° ± 5°	
R10W: BA15s Cap: RY10W: BAU15s in accordance with IEC Publication 60061 RR10W: BAW15s					(sheet 7004-11A-9) 1/ (sheet 7004-19-1) (sheet 7004-11E-1)	
ELECTRICAL AND PHOTOMETRIC CHARACTERISTICS						
Rated values		Volts	6 5/	12	24	12
		Watts	10			10
Test voltage		Volts	6.75	13.5	28	13.5
Objective values	Watts	R10W RY10W	11 max.		14 max.	11 max.
		RR10W	5/	11 max.		11 max.
	Luminous flux	R10W	125 ± 20 %			
		RY10W	75 ± 20 %			
		RR10W	5/	30 ± 25 %		
Reference luminous flux at approximately 13.5 V:		White: 125 lm Amber: 75 lm Red: 30 lm				

- 1/ Filament lamps R10W with cap BA15d may be used for special purposes; they have the same dimensions.
- 2/ Maximum lateral deviation of filament centre from two mutually perpendicular planes both containing the reference axis and one containing the axis of the reference pin.
- 3/ The light emitted from filament lamps of normal production shall be white for category R10W, amber for category RY10W and red for category RR10W. (See also note 4/.)
- 4/ The light emitted from standard filament lamps shall be white for category R10W; white or amber for category RY10W; white or red for category RR10W.
- 5/ Within RR10W no 6 V rated voltage type specified.

CATEGORY W5W, WY5W and WR5W

Sheet W5W/1

The drawings are intended only to illustrate the essential dimensions (in mm) of the filament lamp

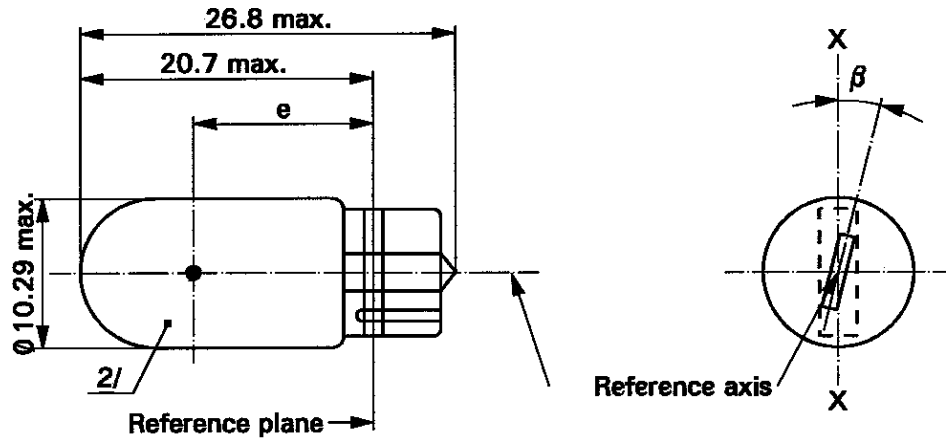

Dimensions in mm		Filament lamps of normal production			Standard filament lamp
		min.	nom.	max.	<u>3/</u>
E		11.2	12.7	14.2	12.7 ± 0.3
Lateral deviation	<u>1/</u>			1.5	0.5 max.
β		- 15°	0°	+ 15°	0° ± 5°
Cap W2.1x9.5d in accordance with IEC Publication 60061 (sheet 7004-91-3)					
ELECTRICAL AND PHOTOMETRIC CHARACTERISTICS					
Rated values	Volts	6 <u>4/</u>	12	24	12
	Watts	5			5
Test voltage	Volts	6.75	13.5	28.0	13.5
Objective values	Watts	5.5 max.		7.7 max.	5.5 max.
	Luminous flux	W5W	50 ± 20 %		
		WY5W	30 ± 20 %		
	WR5W	<u>4/</u>	12 ± 25 %		
Reference luminous flux At approximately 13.5 V:		White: 50 lm Amber: 30 lm Red: 12 lm			

- 1/ Maximum lateral deviation of filament centre from two mutually perpendicular planes both containing the reference axis and one containing axis X-X.
- 2/ The light emitted from filament lamps of normal production shall be white for category W5W, amber for category WY5W and red for category WR5W. (See also note 3/.)
- 3/ The light emitted from standard filament lamps shall be white for category W5W; white or amber for category WY5W; white or red for category WR5W.
- 4/ Within WR5W no 6 V rated voltage type specified.

CATEGORY PY27/7W

Sheet PY27/7W/1

The drawings are intended only to illustrate the essential dimensions (in mm) of the filament lamp

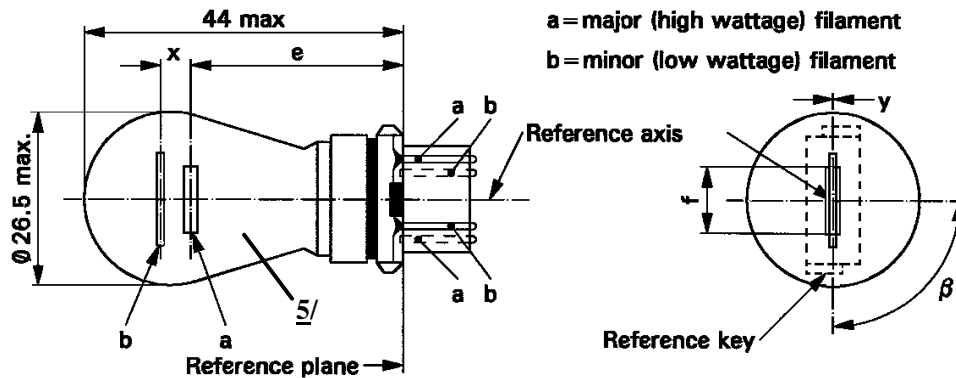

Dimensions in mm	Filament lamps of normal production			Standard filament lamp		
	min.	nom.	max.	6/		
E		27.9 3/		27.9 ± 0.3		
F			9.9	9.9 + 0/ - 2		
Lateral deviation 2/			3/	0.0 ± 0.4		
x 4/		5.1 3/		5.1 ± 0.5		
y 4/		0.0 3/		0.0 ± 0.5		
β	75° 3/	90°	105° 3/	90° ± 5°		
Cap WX2.5x16q in accordance with IEC Publication 60061 (sheet 7004-104A-1)						
ELECTRICAL AND PHOTOMETRIC CHARACTERISTICS						
Rated values	Volts	12			12	
	Watts	27	7		27	7
Test voltage	Volts	13.5			13.5	
Objective values	Watts	32.1 max.	8.5 max.		32.1 max.	8.5 max.
	Luminous flux	280 ± 15 %	21 ± 15 %			
Reference luminous flux at approximately 13.5 V:	White: 475 and 36 lm Amber: 280 and 21 lm					

- 1/ The reference axis is defined with respect to the reference keys and is perpendicular to the reference plane.
- 2/ Maximum lateral deviation of the major (high wattage) filament centre from two mutually perpendicular planes both containing the reference axis and one containing the axis through the reference keys.
- 3/ To be checked by means of a "box-system", sheets P27/7W/2 and 3.
- 4/ "x" and "y" denote the offset of the axis of the minor (low wattage) filament with respect to the axis of the major (high wattage) filament.
- 5/ The light emitted from filament lamps of normal production shall be amber. (See also note 6/)
- 6/ The light emitted from standard filament lamps shall be amber or white.

CATEGORIES P19W, PY19W, PR19W, PS19W, PSY19W AND PSR19W

Sheet P19W/1

The drawings are intended only to illustrate the essential dimensions (in mm) of the filament lamp

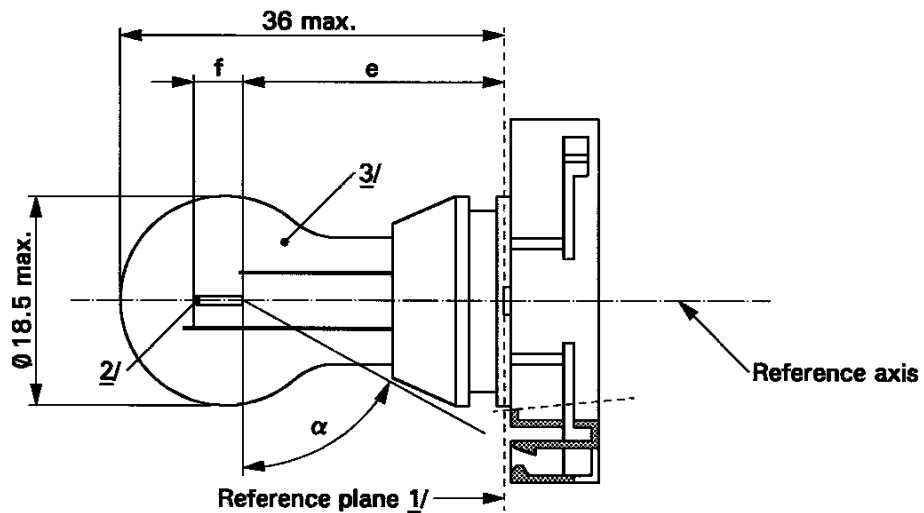

- 1/ The reference plane is defined by the meeting points of the cap-holder fit.
- 2/ No actual filament diameter restrictions apply but the objective is $d \text{ max.} = 1.1 \text{ mm}$.
- 3/ The light emitted from normal production lamps shall be white for categories P19W and PS19W; amber for categories PY19W and PSY19W; red for categories PR19W and PSR19W. (See also note 8/)

CATEGORIES P19W, PY19W, PR19W, PS19W, PSY19W AND PSR19W **Sheet P19W/2**

Dimensions in mm	<u>4/</u>	Filament lamps of normal production			Standard filament lamp	
		min.	nom.	max.	<u>8/</u>	
e	<u>5/</u> <u>6/</u>		24.0		24.0	
f	<u>5/</u> <u>6/</u>		4.0		4.0 ± 0.2	
α	<u>7/</u>	61.5°			61.5° min.	
P19W Cap PGU20-1 PY19W Cap PGU20-2 PR19W Cap PGU20-5 PS19W Cap PG20-1 PSY19W Cap PG20-2 PSR19W Cap PG20-5 <p style="text-align: center;">in accordance with IEC Publication 60061 (sheet 7004-127-1)</p>						
ELECTRICAL AND PHOTOMETRIC CHARACTERISTICS						
Rated values	Volts	12			12	
	Watts	19			19	
Test voltage	Volts	13.5			13.5	
Objective values	Watts	20 max.			20 max.	
	Luminous flux	P19W PS19W	350 ± 15 %			
		PY19W PSY19W	215 ± 20 %			
		PR19W PSR19W	80 ± 20 %			
Reference luminous flux at approximately 13.5 V		White: 350 lm Amber: 215 lm Red: 80 lm				

- 4/ For categories PS19W, PSY19W and PSR19W, dimensions shall be checked with O-ring removed.
- 5/ The filament position is checked by means of a "box-system"; sheet P19W/3.
- 6/ The ends of the filament are defined as the points where, when the viewing direction is perpendicular to the plane through the filament lead-in wires as showed in the drawing on sheet P19W/1, the projection of the outside of the end turns crosses the filament axis.
- 7/ No part of the cap beyond the reference plane shall interfere with angle α. The bulb shall be optically distortion free within the angle 2α + 180°.
- 8/ The light emitted from standard filament lamps shall be white for categories P19W and PS19W; white or amber for categories PY19W and PSY19W; white or red for categories PR19W and PSR19W.

CATEGORIES P19W, PY19W, PR19W, PS19W, PSY19W AND PSR19W

Sheet P19W/3

Screen projection requirements

This test is used to determine, by checking whether the filament is correctly positioned relative to the reference axis and reference plane, whether a filament lamp complies with the requirements.

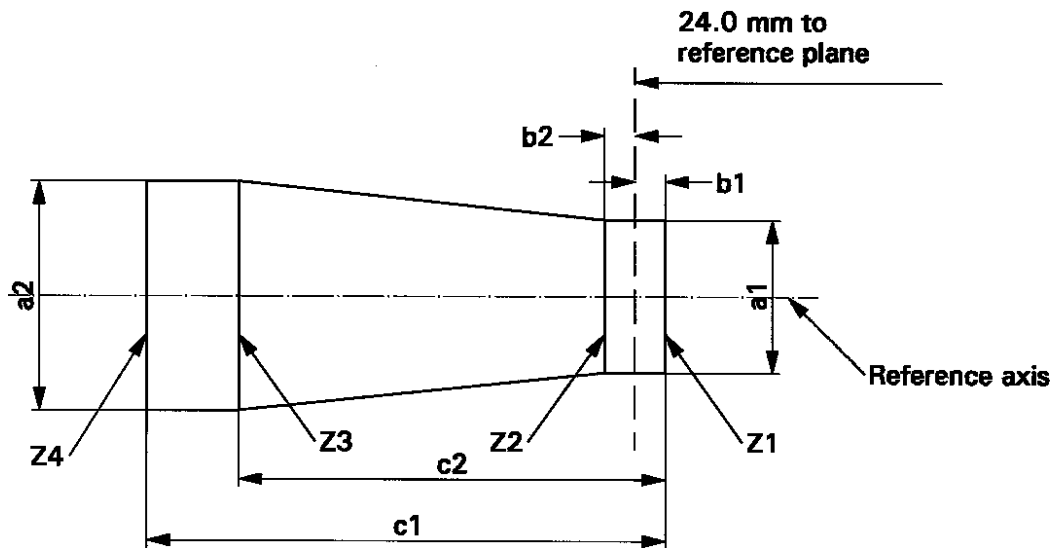

	a1	a2	b1, b2	c1	c2
Filament lamps of normal production	2.9	3.9	0.5	5.2	3.8
Standard filament lamps	1.5	1.7	0.25	4.7	3.8

The filament position is checked in two mutually perpendicular planes, one of them being the plane through the lead-in wires.

The ends of the filament as defined on sheet P19W/2, note 6/, shall lie between Z1 and Z2 and between the lines Z3 and Z4

The filament shall lie entirely within the limits shown.

CATEGORIES P24W, PY24W, PR24W, PS24W, PSY24W AND PSR24W

Sheet P24W/1

The drawings are intended only to illustrate the essential dimensions (in mm) of the filament lamp

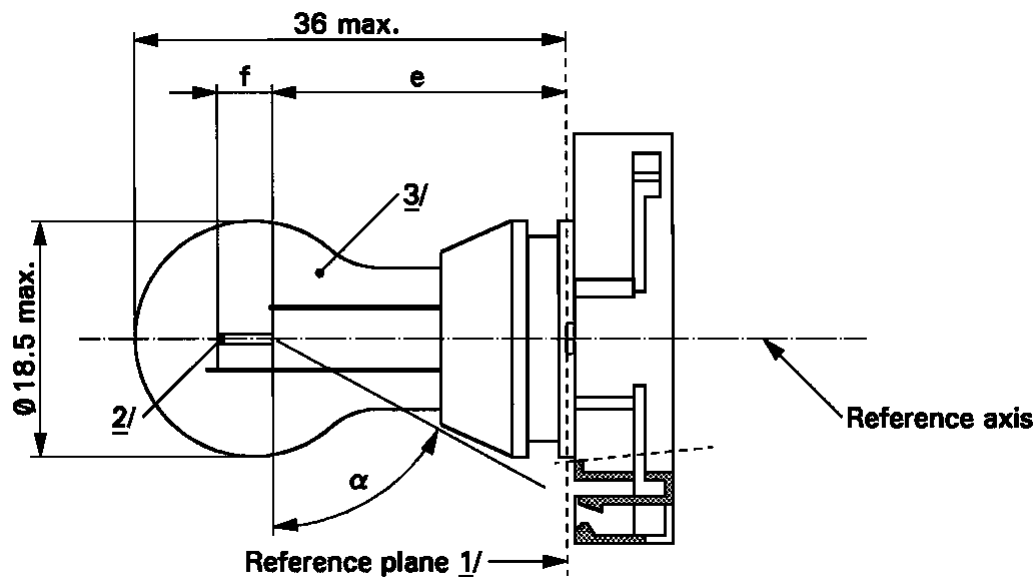

- 1/ The reference plane is defined by the meeting points of the cap-holder fit.
- 2/ No actual filament diameter restrictions apply but the objective is $d_{max} = 1.1$ mm.
- 3/ The light emitted from normal production lamps shall be white for categories P24W and PS24W; amber for categories PY24W and PSY24W; red for the categories PR24W and PSR24W. (See also note 8/)

CATEGORIES P24W, PY24W, PR24W, PS24W, PSY24W AND PSR24W

Sheet P24W/2

Dimensions in mm		Filament lamps of normal production			Standard filament lamp	
		min.	nom.	max.		
e	<u>4/</u> <u>5/</u> <u>6/</u>		24.0		<u>8/</u> 24.0	
f	<u>5/</u> <u>6/</u>		4.0		4.0 ± 0.2	
α	<u>7/</u>	61.5°			61.5° min.	
P24W Cap PGU20-3 PY24W Cap PGU20-4 PR24W Cap PGU20-6 PS24W Cap PG20-3 PSY24W Cap PG20-4 PSR24W Cap PG20-6 <p style="text-align: center;">in accordance with IEC Publication 60061 (sheet 7004-127-1)</p>						
ELECTRICAL AND PHOTOMETRIC CHARACTERISTICS						
Rated values	Volts	12			12	
	Watts	24			24	
Test voltage	Volts	13.5			13.5	
Objective values	Watts	25 max.			25 max.	
	Luminous flux	P24W PS24W	500 +10/-20 %			
		PY24W PSY24W	300 +15/-25 %			
		PR24W PSR24W	115 +15/-25 %			
Reference luminous flux at approximately 13.5 V		White: 500 lm Amber: 300 lm Red: 115 lm				

- 4/ For categories PS24W, PSY24W and PSR24W, dimensions shall be checked with O-ring removed.
- 5/ The filament position is checked by means of a "box-system"; sheet P24W/3.
- 6/ The ends of the filament are defined as the points where, when the viewing direction is perpendicular to the plane through the filament lead-in wires as showed in the drawing on sheet P24W/1, the projection of the outside of the end turns crosses the filament axis.
- 7/ No part of the cap beyond the reference plane shall interfere with angle α. The bulb shall be optically distortion free within the angle 2α + 180°.
- 8/ The light emitted from standard filament lamps shall be white for categories P24W and PS24W; white or amber for categories PY24W and PSY24W; white or red for categories PR24W and PSR24W.

CATEGORIES P24W, PY24W, PR24W, PS24W, PSY24W AND PSR24W

Sheet P24W/3

Screen projection requirements

This test is used to determine, by checking whether the filament is correctly positioned relative to the reference axis and reference plane, whether a filament lamp complies with the requirements.

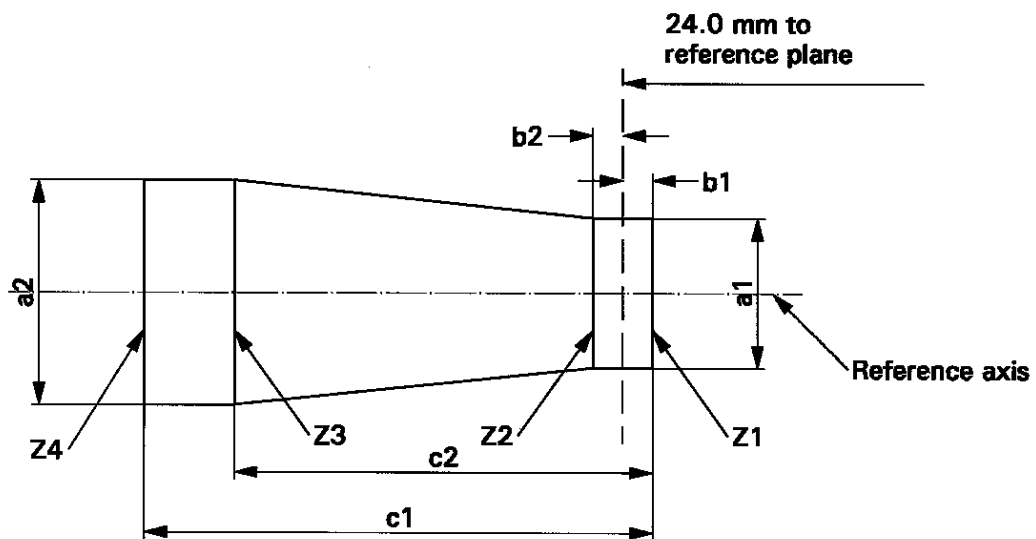

	a1	a2	b1, b2	c1	c2
Filament lamps of normal production	2.9	3.9	0.5	5.2	3.8
Standard filament lamps	1.5	1.7	0.25	4.7	3.8

The filament position is checked in two mutually perpendicular planes, one of them being the plane through the lead-in wires.

The ends of the filament as defined on sheet P24W/2, note 6/, shall lie between Z1 and Z2 and between the lines Z3 and Z4.

The filament shall lie entirely within the limits shown.

CATEGORY PR21W

Sheet PR21W/1

The drawings are intended only to illustrate the essential dimensions (in mm) of the filament lamp

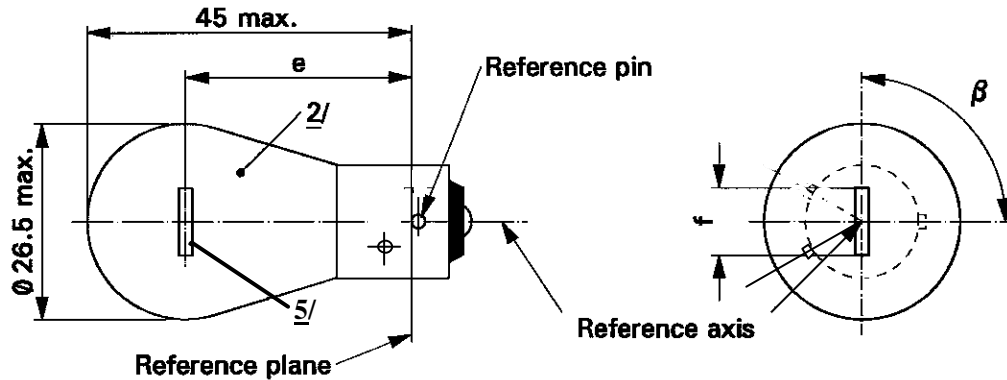

Dimensions in mm		Filament lamps of normal production			Standard filament lamp
		min.	nom.	max.	<u>4/</u>
E	12 V		31.8 <u>3/</u>		31.8 ± 0.3
	24 V	30.8	31.8	32.8	
F	12 V	5.5	6.0	7.0	6.0 ± 0.5
Lateral <u>1/</u> deviation	12 V			<u>3/</u>	0.3 max
	24 V			1.5	
β		75°	90°	105°	90° ± 5°
Cap BAW15s in accordance with IEC Publication 60061 (sheet 7004-11E-1)					
ELECTRICAL AND PHOTOMETRIC CHARACTERISTICS					
Rated values	Volts	12	24	12	
	Watts	21			21
Test voltage	Volts	13.5	28.0		
Objective values	Watts	26.5 max.	29.7 max.	26.5 max.	
	Luminous flux	110 ± 20 %			
Reference luminous flux at approximately 13.5 V:		White:	460 lm		
		Red:	110 lm		

- 1/ Maximum lateral deviation of filament centre from two mutually perpendicular planes both containing the reference axis and one containing the axis of the reference pin.
2/ The light emitted from normal production lamps shall be red (See also note 4/).
3/ To be checked by means of a "box system", sheet P21W/2.
4/ The light emitted from standard filament lamps shall be white or red.
5/ In this view the filament of the 24 V type may be straight or V-shaped. This shall be indicated in the application of approval. If it is straight, the screen projection requirements, sheet P21W/2, apply. If it is V-shaped, the filament ends shall be at the same distance within ± 3 mm from the reference plane.

CATEGORY PR21/4W

Sheet PR21/4W/1

The drawings are intended only to illustrate the essential dimensions (in mm) of the filament lamp

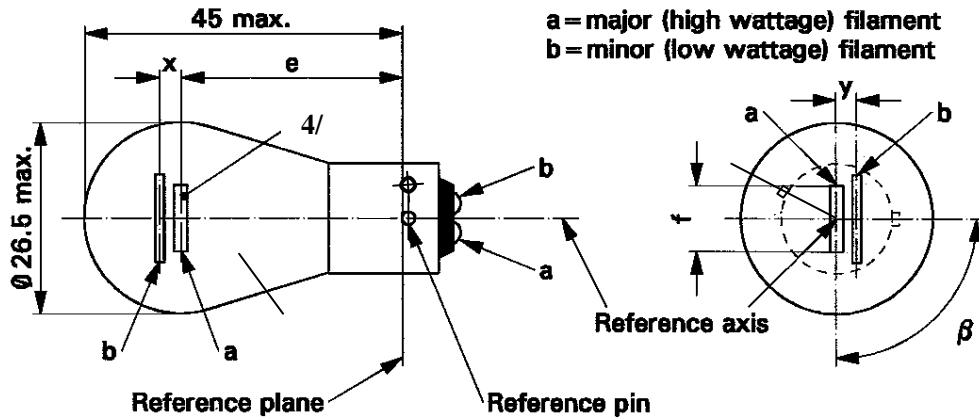

Dimensions in mm	Filament lamps of normal production <u>5/</u>			Standard filament lamp		
	min.	nom.	max.	<u>6/</u>		
E		31.8 <u>1/</u>		31.8 ± 0.3		
F			7.0	7.0 + 0/- 2		
Lateral deviation			<u>1/</u>	0.3 max. <u>2/</u>		
x,y	<u>1/</u>			2.8 ± 0.5		
β	75° <u>1/</u>	90° <u>1/</u>	105° <u>1/</u>	90° ± 5°		
Cap BAU15d in accordance with IEC Publication 60061 (sheet 7004-19-2)						
ELECTRICAL AND PHOTOMETRIC CHARACTERISTICS						
Rated values	Volts	12		24 <u>4/</u>	12	
	Watts	21	4	21	4	21/4
Test voltage	Volts	13.5		28.0		13.5
Objective values	Watts	26.5 max.	5.5 max.	29.7 max.	8.8 max.	26.5/5.5 max.
	Luminous flux ± %	105	4	105	5	
		20	25	20	25	
Reference luminous flux at approximately 13.5 V:	White: 440 lm and 15 lm Red : 105 lm and 4 lm					

- 1/ These dimensions shall be checked by means of a "box-system" 3/ based on the dimensions and tolerances shown above. "x" and "y" refer to the major (high-wattage) filament, not to the reference axis. Means of increasing the positioning accuracy of the filament and of the cap-holder assembly are under consideration.
- 2/ Maximum lateral deviation of the major filament centre from two mutually perpendicular planes both containing the reference axis and one containing the axis of the reference pin.
- 3/ The "Box-System" is the same as for filament lamp P21/5W.
- 4/ The 24-Volt filament lamp is not recommended for future embodiments.
- 5/ The light emitted from normal production lamps shall be red (See also note 6/).
- 6/ The light emitted from standard filament lamps shall be white or red.

CATEGORY PR21/5W

Sheet PR21/5W/1

The drawings are intended only to illustrate the essential dimensions (in mm) of the filament lamp

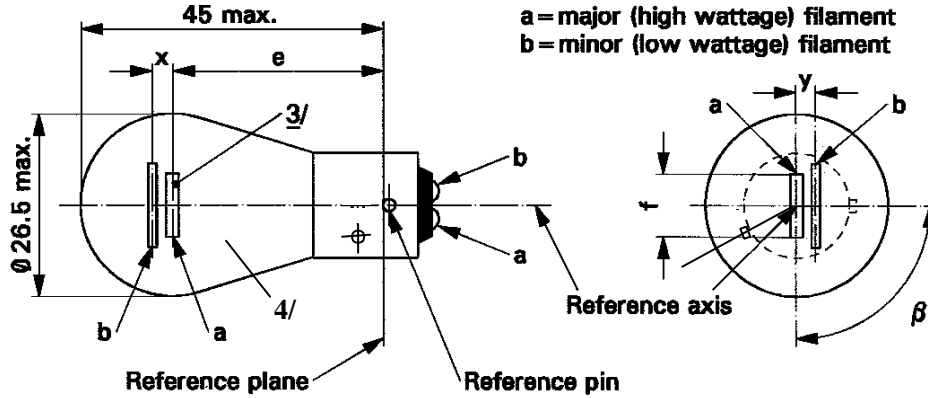

Dimensions in mm		Filament lamps of normal production 4/			Standard filament lamp	
		min.	nom.	max.	5/	
E	12 V		31.8 1/		31.8 ± 0.3	
	24 V	30.8	31.8	32.8		
F	12 V			7.0	7.0 + 0/- 2	
Lateral deviation 2/	12 V			1/	0.3 max.	
	24 V			1.5		
x, y	12 V		1/		2.8 ± 0.3	
X	24 V 3/	-1.0	0	1.0		
Y	24 V 3/	1.8	2.8	3.8		
β		75°	90°	105°	90° ± 5°	
Cap BAW15d in accordance with IEC Publication 60061 (sheet 7004-11E-1)						
ELECTRICAL AND PHOTOMETRIC CHARACTERISTICS						
Rated values	Volts	12		24		12
	Watts	21	5	21	5	21/5
Test voltage	Volts	13.5		28.0		13.5
Objective values	Watts	26.5 max.	6.6 max.	29.7 max.	11.0 max.	26.5 and 6.6 max.
	Luminous flux ± %	105	8	105	10	
		20	25	20	25	
Reference luminous flux at approximately 13.5 V:		White: 440 lm and 35 lm Red: 105 lm and 8 lm				

- 1/ See footnote 1/ on sheet P21/5W/2
 2/ See footnote 2/ on sheet P21/5W/2
 3/ See footnote 3/ on sheet P21/5W/2
 4/ The light emitted from normal production lamps shall be red (See also note 5/).
 5/ The light emitted from standard filament lamps shall be white or red.

CATEGORY PR27/7W

Sheet PR27/7W/1

The drawings are intended only to illustrate the essential dimensions (in mm) of the filament lamp

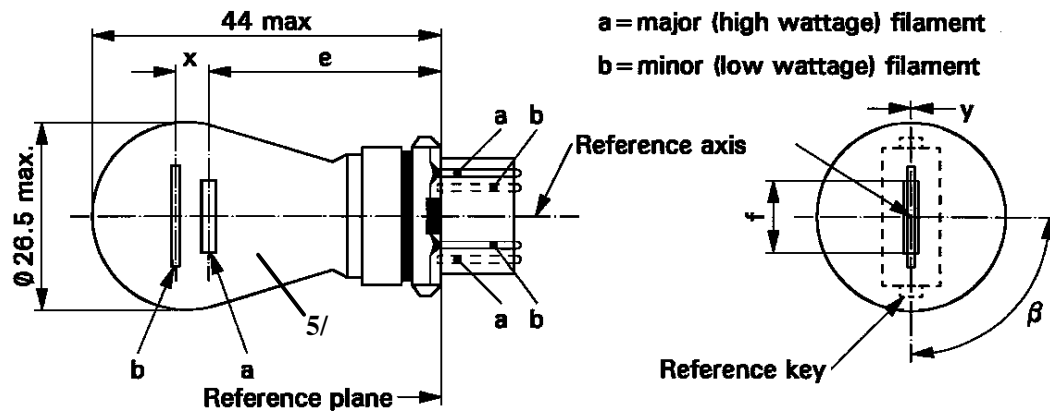

Dimensions in mm	Filament lamps of normal production			Standard filament lamp		
	min.	nom.	max.	6/		
E		27.9 3/		27.9 ± 0.3		
F			9.9	9.9 + 0/ - 2		
Lateral deviation 2/			3/	0.0 ± 0.4		
x 4/		5.1 3/		5.1 ± 0.5		
y 4/		0.0 3/		0.0 ± 0.5		
β	75° 3/	90°	105° 3/	90° ± 5°		
Cap WU2.5x16 in accordance with IEC Publication 60061 (sheet 7004-104D-1)						
ELECTRICAL AND PHOTOMETRIC CHARACTERISTICS						
Rated values	Volts	12			12	
	Watts	27	7	27	7	
Test voltage	Volts	13.5			13.5	
Objective values	Watts	32.1 max.	8.5 max.	32.1 max.	8.5 max.	
	Luminous flux	110 ± 20 %	9 ± 20 %			
Reference luminous flux at approximately 13.5 V:		White: 475 and 36 lm Red: 110 and 9 lm				

- 1/ The reference axis is defined with respect to the reference keys and is perpendicular to the reference plane.
- 2/ Maximum lateral deviation of the major (high wattage) filament centre from two mutually perpendicular planes both containing the reference axis and one containing the axis through the reference keys.
- 3/ To be checked by means of a "box system", sheets P27/7W/2 and 3.
- 4/ "x" and "y" denote the offset of the axis of the minor (low wattage) filament with respect to the axis of the major (high wattage) filament.
- 5/ The light emitted from normal production lamps shall be red (See also note 6/).
- 6/ The light emitted from standard filament lamps shall be white or red.

CATEGORY HS5

Sheet HS5/1

The drawings are intended only to illustrate the essential dimensions (in mm) of the filament lamp

FILAMENT LAMP FOR MOTORCYCLES

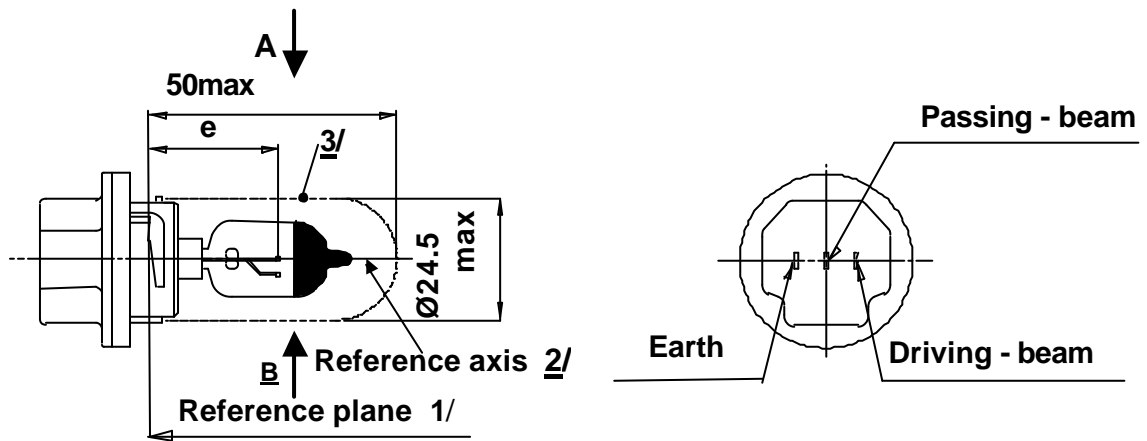

Figure 1 Main drawing

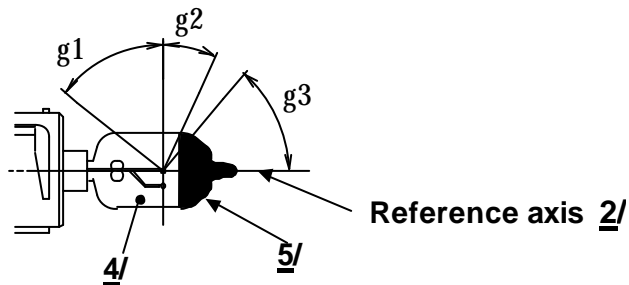

Figure 2 Distortion free area 4/ and black top 5/

- 1/ The reference plane is defined by the three ramp inside surface.
- 2/ The reference axis is perpendicular to the reference plane and passing through the centre of the 23 mm cap diameter.
- 3/ Glass bulb and supports shall not exceed the envelope as indicated in figure 1. The envelope is concentric to the reference axis.
- 4/ Glass bulb shall be optically distortion free within the angles γ_1 and γ_2 . This requirement applies to the whole bulb circumference within the angles γ_1 and γ_2 .
- 5/ The obscuration shall extend at least to angle γ_3 and shall extend at least to the cylindrical part of the bulb on the whole top circumference.

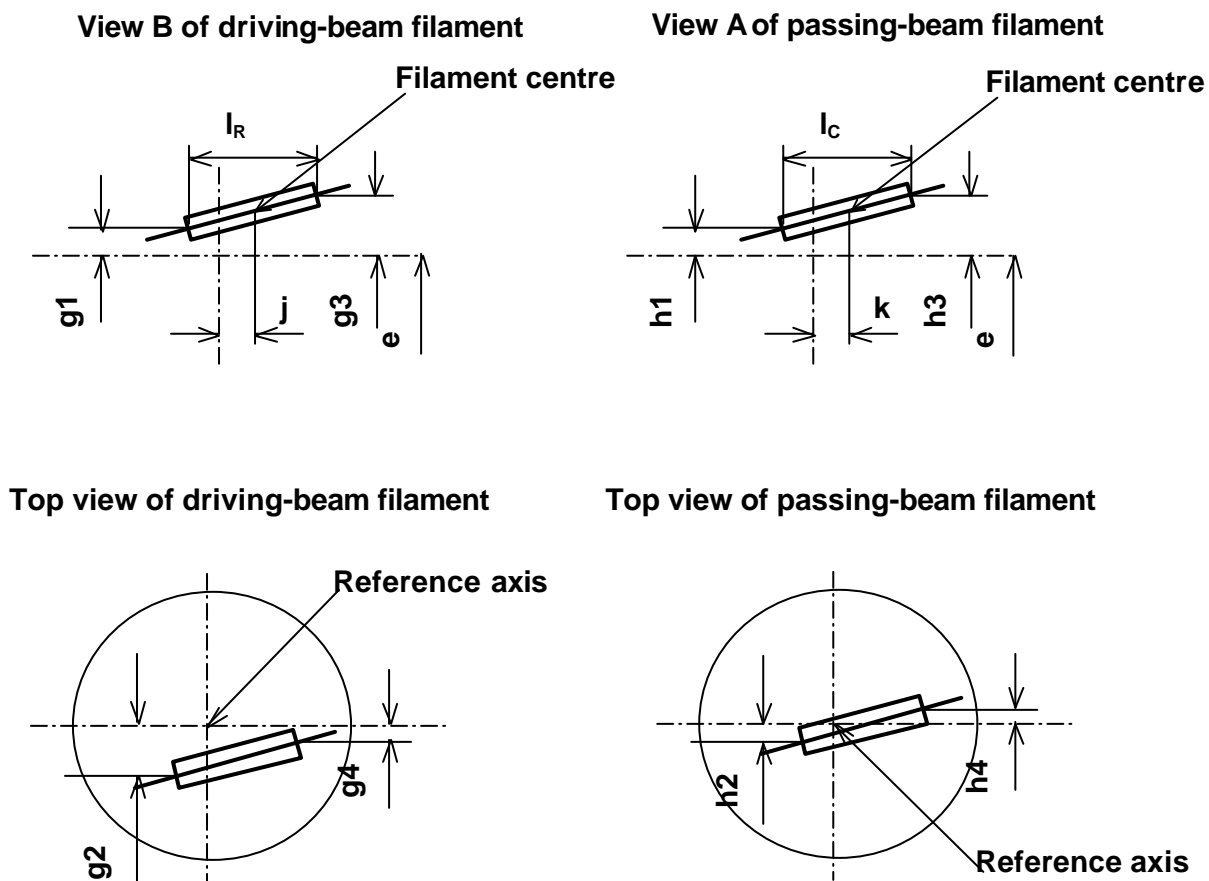

Figure 3
Filament position and dimensions

CATEGORY HS5

Sheet HS5/3

Dimensions in mm		Filament lamps of normal production		Standard filament lamp		
		12V		12V		
e	26	<u>6/</u>		± 0.15		
l _c	<u>Z/</u> 4.6			± 0.3		
k	0			± 0.2		
h ₁ , h ₃	0			± 0.15		
h ₂ , h ₄	0			± 0.20		
l _R	<u>Z/</u> 4.6			± 0.3		
j	0			± 0.2		
g ₁ , g ₃	0			± 0.30		
g ₂ , g ₄	2.5			± 0.40		
γ ₁	50° min.	-		-		
γ ₁	23° min.	-		-		
γ ₁	50° min.	-		-		
Cap P23t in accordance with IEC Publication 60061 (sheet 7004-....-1)						
ELECTRICAL AND PHOTOMETRIC CHARACTERISTICS						
Rated values	Voltage	V	12		12	
	Wattage	W	35	30	35	30
Test voltage		V	13.2		13.2	
Objective Values	Wattage	W	40 max.	37 max.	40 max.	37 max.
	Luminous flux	lm	620	515		
		± %		15	15	
Reference luminous at approximately 12V					460 lm	380 lm

6/ To be checked by means of a "box-system". Sheet HS5/4.

Z/ The positions of the first and the last turn of the filament are defined by the intersections of the outside of the first and the outside of the last light-emitting turn, respectively, with the plane parallel to and 26 mm distant from the reference plane.

Screen projection requirement

This test is used to determine whether a filament lamp complies with the requirements by checking whether:

- (a) the passing-beam filament is correctly positioned relative to the reference axis and the reference plane; and whether
- (b) the driving-beam filament is correctly positioned relative to the passing-beam filament.

Side elevation

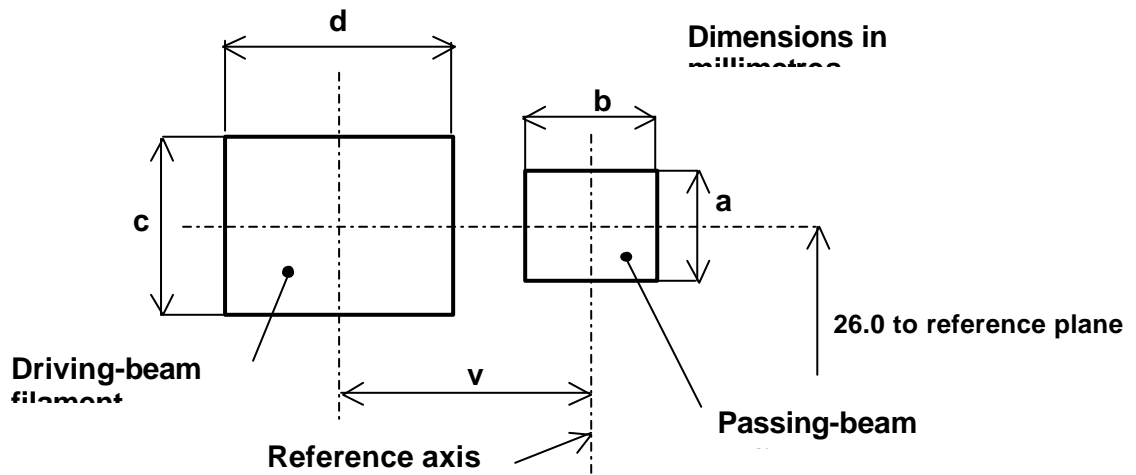

Reference	a	b	c	d	v
Dimensions	$d1+0.6$	$d1+0.8$	$d2+1.2$	$d2+1.6$	2.5

$d1$: Diameter of the passing-beam filament
 $d2$: Diameter of the driving-beam filament

Front elevation

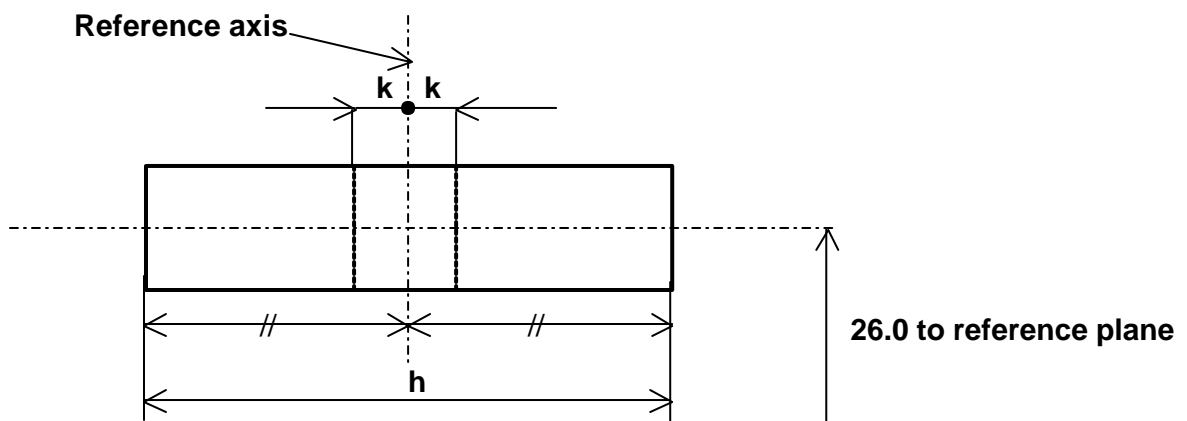

Reference	h	k
Dimensions	6.0	0.5

The filaments shall lie entirely within the limits shown.
 The centre of the filament shall lie within the limits of dimension k.