



**Economic and Social
Council**

Distr.
GENERAL

TRANS/WP.29/932
23 July 2003

ENGLISH
Original: ENGLISH AND FRENCH

ECONOMIC COMMISSION FOR EUROPE

INLAND TRANSPORT COMMITTEE

World Forum for Harmonization of Vehicle Regulations (WP.29)

DRAFT SUPPLEMENT 15 TO THE 04 SERIES
OF AMENDMENTS TO REGULATION No. 16

(Safety-belts)

Note: The text reproduced below was adopted by the Administrative Committee (AC.1) of the amended 1958 Agreement at its twenty-fourth session, following the recommendation of WP.29 at its one-hundred-and-thirtieth session. It is based on document TRANS/WP.29/2003/37, not amended (TRANS/WP.29/926, para. 100).

The title of the Regulation, amend to read:

"UNIFORM PROVISIONS CONCERNING THE APPROVAL OF:

- I. SAFETY-BELTS, RESTRAINT SYSTEMS, CHILD RESTRAINT SYSTEMS AND ISOFIX CHILD RESTRAINT SYSTEMS FOR OCCUPANTS OF POWER-DRIVEN VEHICLES
- II. VEHICLES EQUIPPED WITH SAFETY-BELTS, RESTRAINT SYSTEMS, CHILD RESTRAINT SYSTEMS, AND ISOFIX CHILD RESTRAINT SYSTEMS"

Paragraph 1., amend to read:

- "1. This Regulation applies to safety-belts and restraint systems which are designed for installation in vehicles and are intended for separate use, i.e. as individual fittings, by persons of adult build occupying forward or rearward-facing seats. It also applies to child restraint systems and ISOFIX child restraint systems designated for installation in vehicles of category M1 and N1. */

*/ As defined in the Consolidated Resolution of Construction of Vehicles (R.E.3), annex 7 (document TRANS/WP.29/78/Rev.11/Amend.2)"

Insert new paragraphs 2.28. to 2.37., to read:

- "2.28. "ISOFIX" is a system for the connection of child restraint systems to vehicles which has two vehicle rigid anchorages, two corresponding rigid attachments on the child restraint system, and a mean to limit the pitch rotation of the child restraint system.
- 2.29. "ISOFIX child restraint system" means a child restraint system, fulfilling the requirements of Regulation No. 44, which has to be attached to an ISOFIX anchorages system, fulfilling the requirements of Regulation No. 14.
- 2.30. "ISOFIX position" means a system which allows to install:
 - a) either a universal ISOFIX forward facing child restraint system as defined in Regulation No. 44,
 - b) or a semi-universal ISOFIX forward facing child restraint system as defined in Regulation No. 44,
 - c) or a semi-universal ISOFIX rearward facing child restraint system as defined in Regulation No. 44,

- d) or a semi-universal ISOFIX lateral facing position child restraint system as defined in Regulation No. 44,
 - e) or a specific vehicle ISOFIX child restraint system as defined in Regulation No. 44.
- 2.31. "ISOFIX anchorages system" means a system made up of two ISOFIX low anchorages, fulfilling the requirements of Regulation No. 14, and which is designed for attaching an ISOFIX child restraint system in conjunction with an anti-rotation device.
- 2.32. "ISOFIX low anchorage" means one 6 mm diameter rigid round horizontal bar, extending from vehicle or seat structure to accept and restrain an ISOFIX child restraint system with ISOFIX attachments.
- 2.33. "Anti-rotation device"
- a) An anti-rotation device for an ISOFIX universal child restraint system consists of the ISOFIX top-tether.
 - b) An anti-rotation device for an ISOFIX semi-universal child restraint system consists of a top tether, the vehicle dashboard or a support leg intended to limit the rotation of the restraint during a frontal impact.
 - c) For ISOFIX, universal and semi-universal, child restraint systems the vehicle seat itself does not constitute an anti-rotation device.
- 2.34. "ISOFIX top tether anchorage" means a feature, fulfilling the requirements of Regulation No. 14, such as a bar, located in a defined zone, designed to accept an ISOFIX top tether strap connector and transfer its restraint force to the vehicle structure.
- 2.35. A "guidance device" is intended to help the person installing the ISOFIX child restraint system by physically guiding the ISOFIX attachments on the ISOFIX child restraint into correct alignment with the ISOFIX low anchorages to facilitate engagement.
- 2.36. "ISOFIX marking fixture" means something that informs someone wishing to install an ISOFIX child restraint system of the ISOFIX positions in the vehicle and the position of each corresponding ISOFIX anchorages system.
- 2.37. "Child restraint fixture" (CRF) means a fixture according to one out of the seven ISOFIX size classes defined in paragraph 4. of annex 17 - appendix 2 of this Regulation, and particularly whose dimensions are given from figure 1 to figure 6 in the previous mentioned paragraph 4. Those child restraint fixtures (CRF) are used, in this Regulation, to check what are the ISOFIX child restraint systems size classes which can be accommodated on the vehicle ISOFIX positions. Also one of

the CRF, the so-called ISO/F2 (B), which is described in figure 2 of the previous mentioned paragraph 4., is used in Regulation No. 14 to check the location and the possibility of access to any ISOFIX anchorages system."

Paragraph 5.2.4.1. footnote 1/, amend to read:

" ... 10 for Serbia and Montenegro, 35 (vacant), 36 for Lithuania, ... 38 (vacant), 39 for Azerbaijan,....46 for Ukraine, 47 for South Africa and 48 for New Zealand."

Paragraph 8.2.1., amend to read:

"8.2.1. Safety-belts, restraint systems, and ISOFIX child restraint systems according to table 2 of annex 17 - appendix 3, shall be fixed to anchorages conforming to the specifications of Regulation No. 14, such as the design and dimensional characteristics, the number of anchorages, and the strength requirements."

Paragraph 8.2.2., amend to read:

"8.2.2. The safety-belts, restraint systems, child restraint systems and ISOFIX child restraint systems recommended by the manufacturer according to tables 1 and 2 of annex 17 - appendix 3, shall be so installed that they will work

Paragraph 8.2.2.3., amend to read:

".....vehicle or seat structure, child restraint systems or ISOFIX child restraint systems recommended by the manufacturer according to tables 1 and 2 of annex 17 - appendix 3, is reduced to a minimum."

Paragraph 8.3.5., amend to read:

" requirements of annex 17. Any vehicle of category M1 must be equipped at least with two ISOFIX positions; at least two of them shall be equipped with an ISOFIX top tether anchorage. One of the two ISOFIX positions shall be installed at the second seat row. The first ISOFIX position shall allow at least the installation of one out of the two forward-facing fixtures as defined in appendix 2 of annex 17; the second ISOFIX position allowing at least the installation of one out of the three rear-facing fixtures as defined in appendix 2 of annex 17. For this second ISOFIX position, in case where the installation of the rear-facing fixture is not possible on the second row of seats of the vehicle due to its design, the installation of one out of the five fixtures is allowed in any position of the vehicle."

Paragraph 15.1.1., amend to read:

"15.1.1. As from the official date of entry into force of Supplement 15 to the 04 series of amendments, no Contracting Party as amended by Supplement 15 to the 04 series of amendments."

Paragraph 15.1.2., amend to read:

"15.1.2. As from 2 years after the enter into force of Supplement 15 to the 04 series of amendments to this Regulation, Contracting Parties applying this Regulation shall grant ECE approvals only if the requirements of this Regulation, as amended by Supplement 15 to the 04 series of amendments are satisfied."

Paragraph 15.1.3., amend to read:

"15.1.3. As from 7 years after enter into force of Supplement 15 to the 04 series of amendments to this Regulation, Contracting Parties applying this Regulation may refuse to recognize approvals which were not granted in accordance with Supplement 15 to the 04 series of amendments to this Regulation."

Annex 17.

The title of annex 17., amend to read:

"Annex 17

"REQUIREMENTS FOR THE INSTALLATION OF SAFETY-BELTS
....ON FORWARD FACING SEATS,
AND FOR THE INSTALLATION OF ISOFIX CHILD RESTRAINT SYSTEMS"

Paragraph 1.1., amend to read:

".... of the country in which the vehicle is offered for sale.

For each forward facing passenger seat position, and for each ISOFIX position, the vehicle manufacturer shall either:

- a)
- b) Indicate if the ISOFIX_{position} is suitable for ISOFIX child restraint systems of the universal category (see paragraph 1.2. below)
- c) Provide a list of ISOFIX child restraint systems child restraint systems of the "semi-universal", "restricted" or "vehicle specific" categories, suitable for that vehicle seating position, ..."
- d) Provide a list of ISOFIX child restraint systems of the "semi-universal", "restricted" or "vehicle specific" categories, suitable for that vehicle ISOFIX position, indicating the mass group and the ISOFIX size class for which the ISOFIX child restraint are intended.
- e) Provide a built-in child restraint system, indicating

- f) Provide any combination of (a),(b), (c), (d),(e).
- g) Indicate the mass

If a seat forward-facing child restraint systems, this shall be indicated.

Tables in a suitable format for the above information are given in appendix 3 to this annex."

Paragraph 1.2., amend to read:

"1.2. A child restraint system or ISOFIX child restraint system, of the universal category means a child restraint approved to the "universal" category of Regulation No. 44, Supplement 5 to 03 series of amendments. Seat positions, or ISOFIX positions, which are indicated by the vehicle manufacturer as being suitable for the installation of child restraints systems or ISOFIX child restraints systems shall comply with the provisions of appendix 1 or 2 to this annex. Where applicable any restriction on the simultaneous use on adjacent positions of ISOFIX child restraint systems and/or between ISOFIX positions and adult seating positions shall be reported in the table 2 of appendix 3 to this annex."

Annex 17 – Appendix 1,

Paragraph 3.3., amend to read:

"... again verified and met. This alternative position shall be included as an information in the table 1 given in appendix 3 to this annex."

Insert a new appendix 2 to annex 17, to read:

"Annex 17 - Appendix 2

PROVISIONS CONCERNING THE INSTALLATION OF FORWARD-FACING AND
REARWARD-FACING ISOFIX CHILD RESTRAINT SYSTEMS OF UNIVERSAL AND SEMI-
UNIVERSAL CATEGORIES INSTALLED ON ISOFIX POSITIONS

- 1. General
 - 1.1. The test procedure and the requirements in this appendix shall be used to determine the suitability of ISOFIX positions for the installation of ISOFIX child restraint systems of universal and semi-universal categories.
 - 1.2. The tests may be carried out in the vehicle or in a representative part of the vehicle.

2. Test procedure

For any ISOFIX position in the vehicle, as indicated by the car manufacturer, in table 2 of appendix 3, it has to be checked that it is possible to accommodate the corresponding child restraint fixture(s) (CRF):

2.1. When checking a CRF on a seat, this seat may be adjusted longitudinally to its rearmost position and in its lowest position.

2.2. Adjust the seat-back angle to the manufacturer's design position and the head restraint in the lowest and rearmost position. In the absence of any specification an angle of the seat-back corresponding to a torso angle of 25° from the vertical, or the nearest fixed position of the seat-back, shall be used.

When checking a CRF on a rear seat, the vehicle seat located in front of this rear seat may be adjusted longitudinally forward but not further than the mid position between its rearmost and fore most positions. The seat backrest angle may also be adjusted, but not to a more upright angle than corresponding to a torso angle of 15° .

2.3. Place a cotton cloth on the seat-back and cushion.

2.4. Place the CRF on the ISOFIX position.

2.5. Push, towards ISOFIX anchorages system, on the center between the ISOFIX anchorages with a force of $100\text{ N} \pm 10\text{ N}$, applied parallel to the lower surface, and remove the force.

2.6. Attach the CRF to the ISOFIX anchorages system.

2.7. Push vertically downwards on the centre of the upper surface of the fixture with a force of $100\text{ N} \pm 10\text{ N}$, and remove the force.

3. Requirements

The following testing conditions only apply for the CRF(s) when accommodated in the ISOFIX position. It is not required that the CRF(s) shall be possible to move in and out of the ISOFIX position under these conditions.

3.1. It has to be possible to accommodate the CRF(s) without interference with the vehicle interior. The CRF base shall have a pitch angle of $15^\circ \pm 10^\circ$, above the horizontal plane passing through the ISOFIX anchorages system.

3.2. The ISOFIX top tether anchorage, if any, shall remain accessible.

3.3. Should the above requirements not be met with the adjustments indicated in paragraph 2. above, the seats, the seat-backs, the head restraints may be adjusted to alternative positions designated by the manufacturer for normal use following

which the above installation procedure shall be repeated and the requirements verified and met. These alternative positions shall be included as information in table 2 given in appendix 3 to this annex.

3.4 Should the above requirements not be fulfilled when some removable interior fittings were present, such fittings may be removed and then requirements of paragraph 3. have to be verified again and fulfilled. In such a case corresponding information shall be included in table 2 of appendix 3 of this annex.

4. ISOFIX child restraint system size classes and fixtures

A - ISO/F3: Full-Height Forward Facing toddler CRS

B - ISO/F2: Reduced-Height Forward Facing toddler CRS

C - ISO/R3: Full-Size Rearward Facing toddler CRS

D - ISO/R2: Reduced-Size Rearward Facing toddler CRS

E - ISO/R1: Rearward Facing infant CRS

F – ISO/L1: Left Lateral Facing position CRS (carry-cot)

G - ISO/L2: Right Lateral Facing position CRS (carry-cot)

Mass group	ISOFIX size class	Fixture (CRF)
group 0 up to 10 kg	F	ISO/L1
	G	ISO/L2
	E	ISO/R1
group 0+ up to 13 kg	C	ISO/R3
	D	ISO/R2
	E	ISO/R1
group I 9 to 18 kg	A	ISO/F3
	B	ISO/F2
	C	ISO/R3
	D	ISO/R2

4.1. Full-height forward-facing toddler child restraint systems envelope.

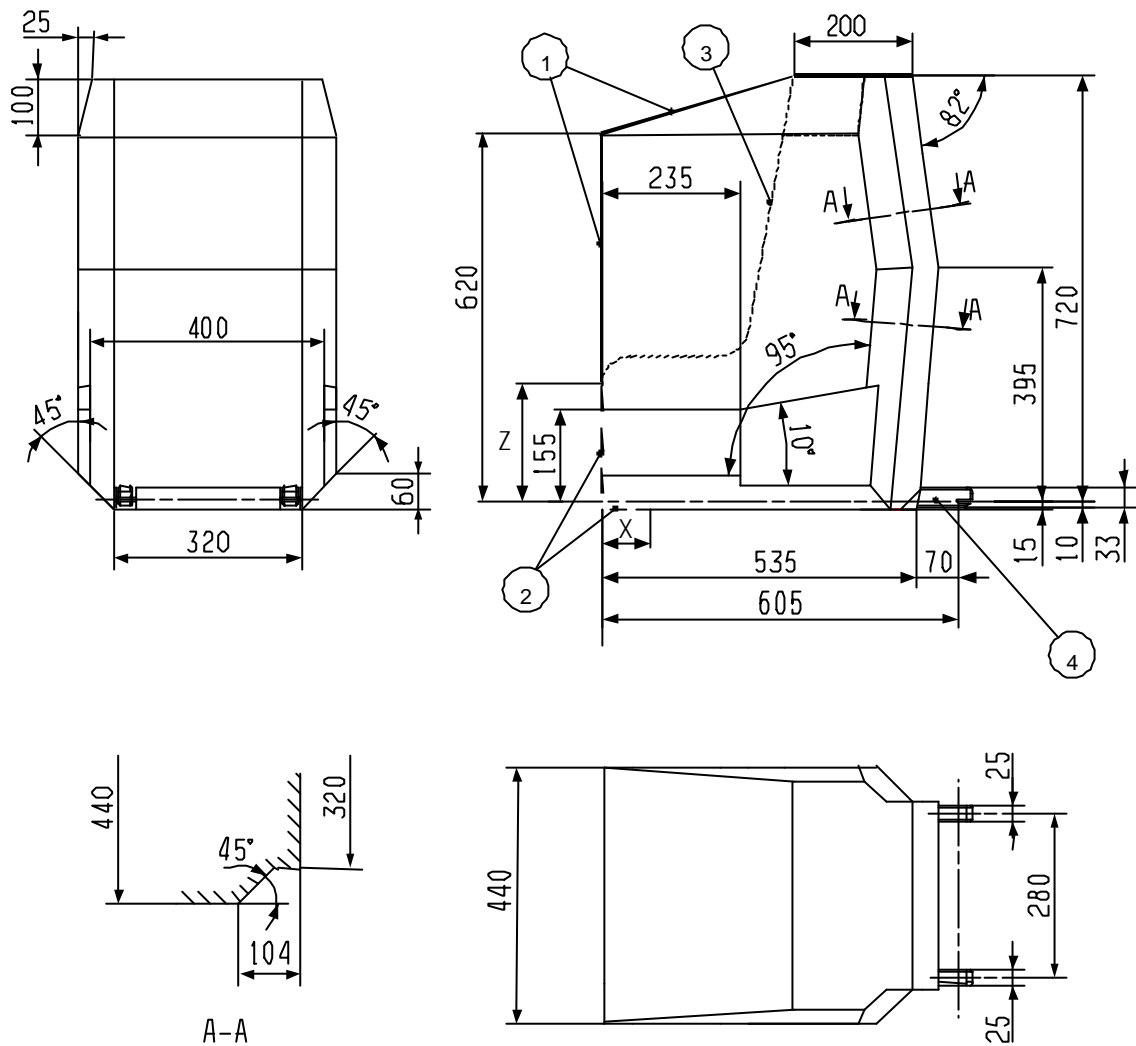

Key

- 1 Limits in the forward and upwards directions
- 2 Dashed line marks area where a support leg, or similar, is allowed to protrude
- 3 N/A
- 4 Further specifications of the connector area is given in R44

Figure 1 – ISO/F3 envelope dimensions for a full-height forward-facing toddler CRS (height 720 mm) - ISOFIX SIZE CLASS A

4.2. Reduced-height forward-facing toddler child restraint systems envelope.

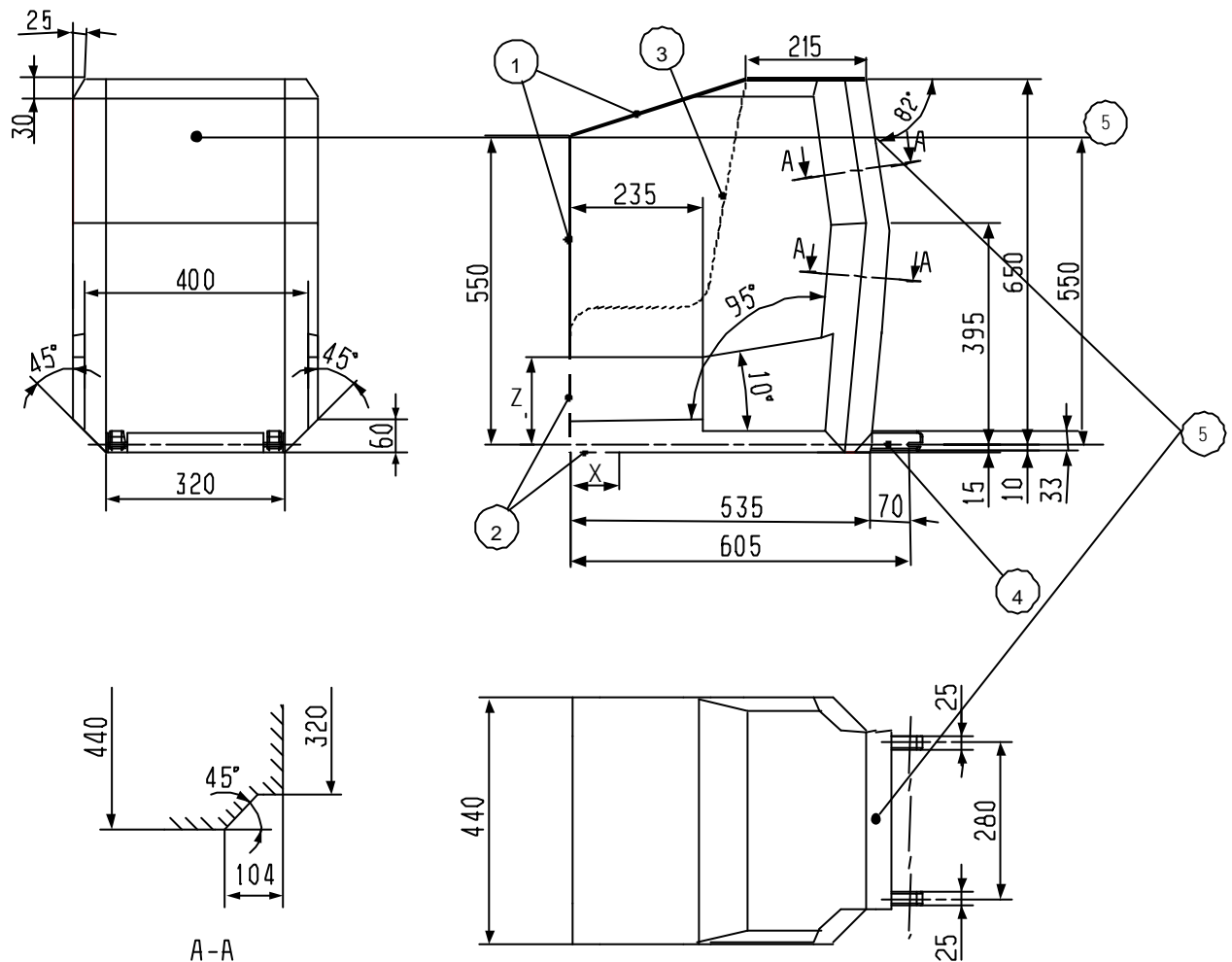

Key

- 1 Limits in the forward and upwards directions
- 2 Dashed line marks area where a support leg, or similar, is allowed to protrude
- 3 Shape of CRF for positioning purpose in R14
- 4 Further specifications of the connector area is given in R44
- 5 ISOFIX top tether attachment

Figure 2 – ISO/F2 envelope dimensions for a reduced-height forward-facing toddler CRS, (height 650 mm) – ISOFIX SIZE CLASS B

4.3. Full-size rearward facing toddler child restraint systems envelope

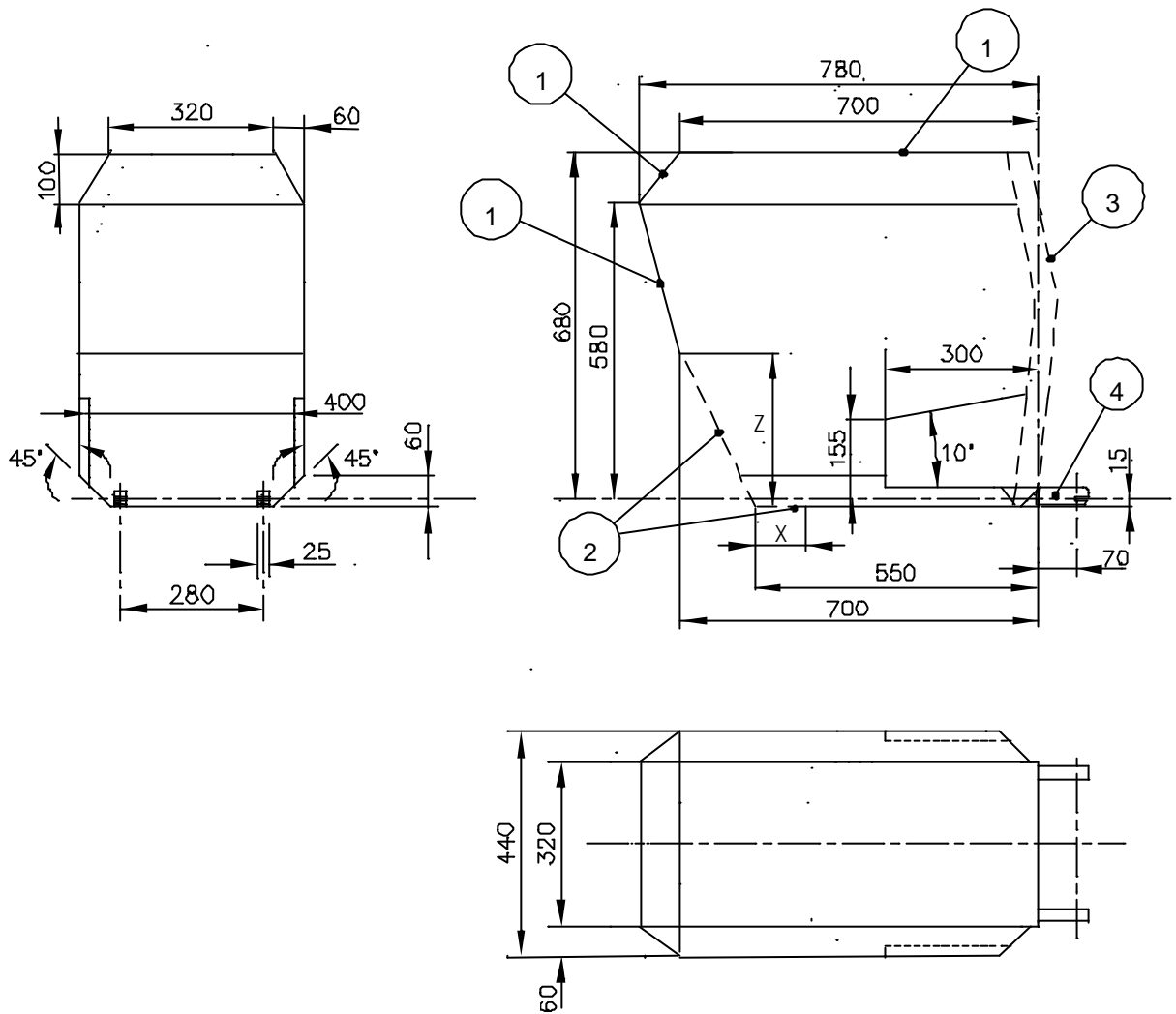

Key

- 1 Limits in the rearward and upwards directions
- 2 Dashed line marks area where a support leg, or similar, is allowed to protrude
- 3 The backwards limitation (to the right in the figure) is given by the forward-facing envelope in Figure 2
- 4 Further specifications of the connector area is given in R44

Figure 3 – ISO/R3 envelope dimensions for a full-size rearward-facing toddler CRS – ISOFIX SIZE CLASS C

4.4. Reduced-size rearward-facing toddler child restraint systems envelope

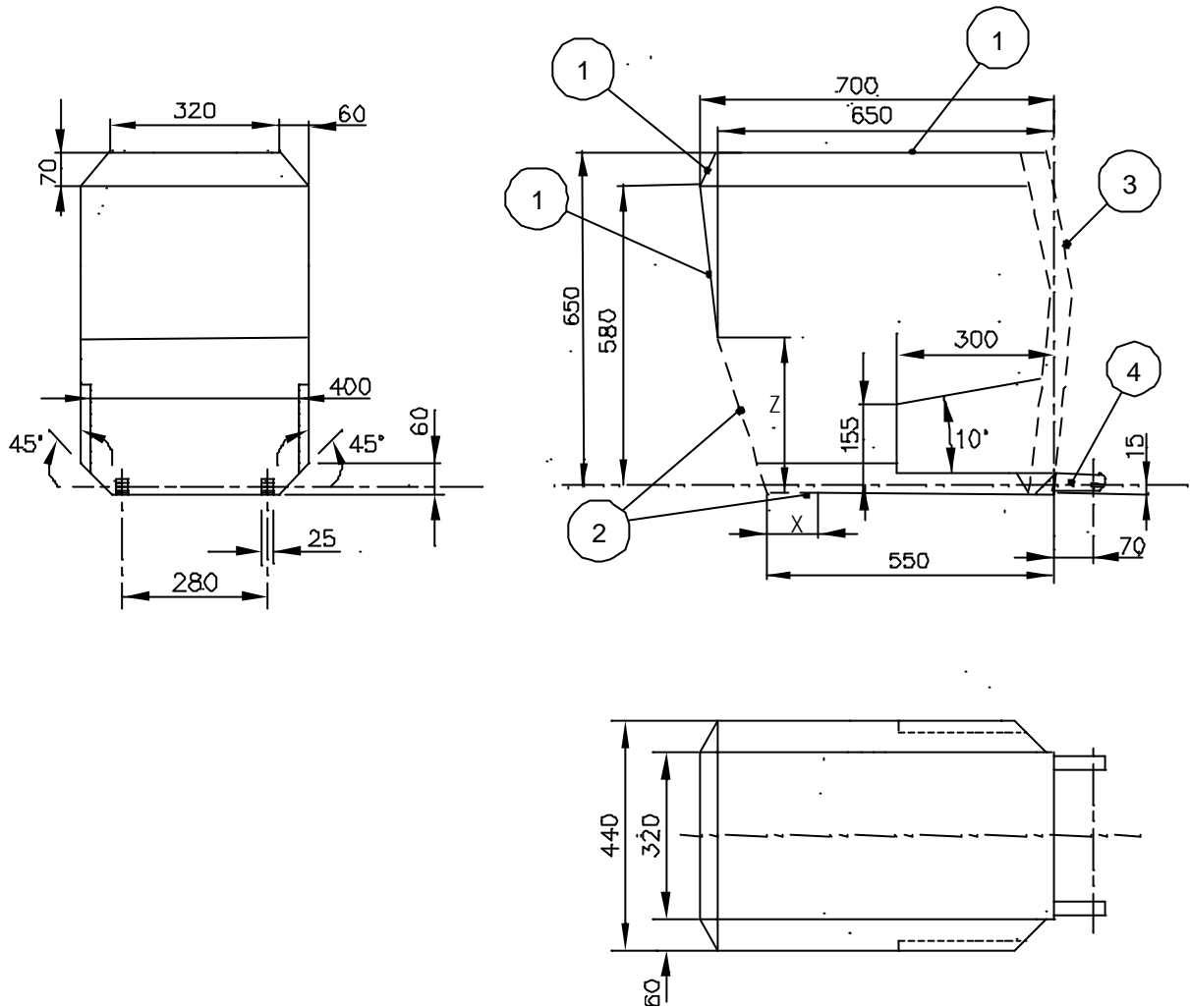
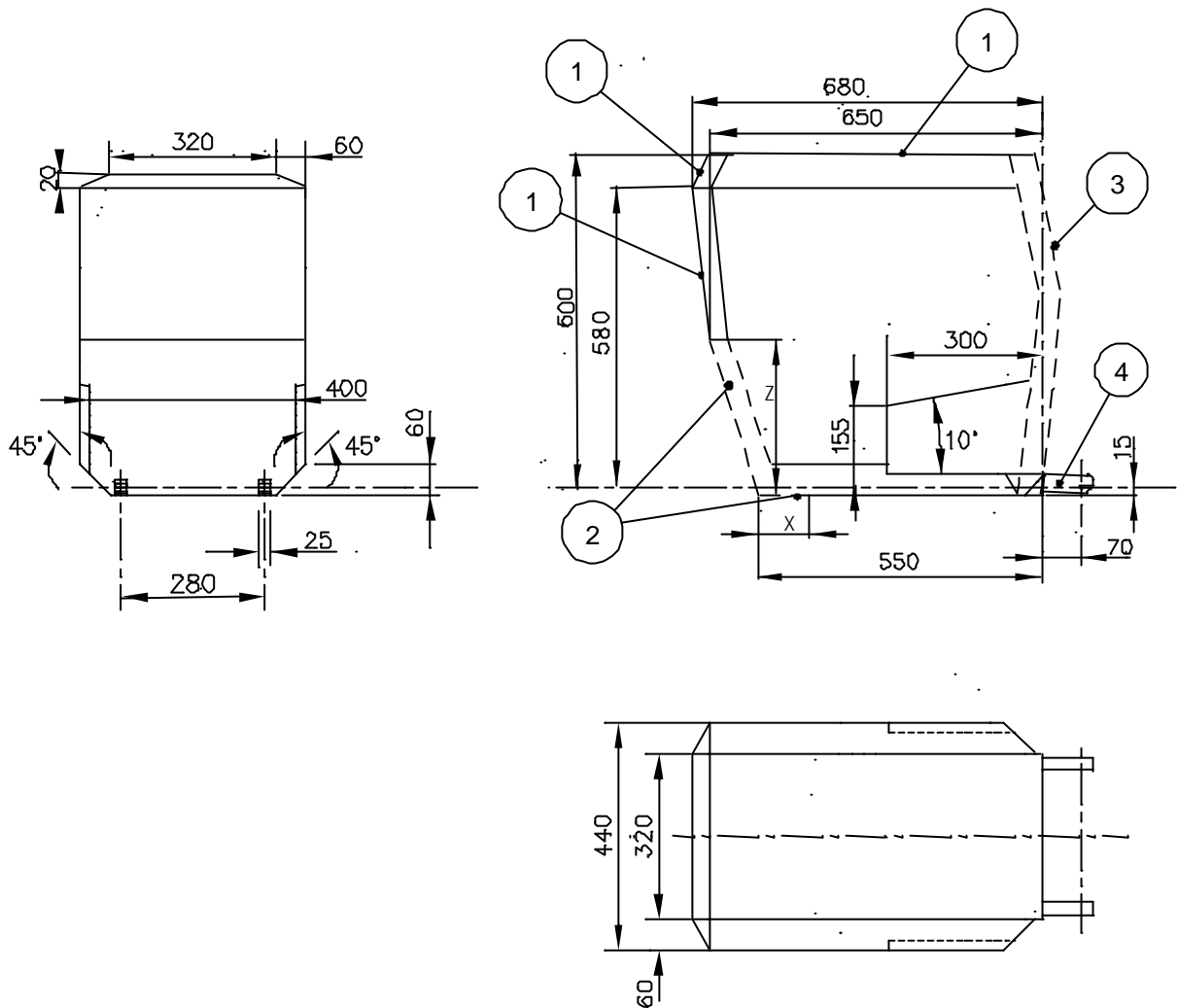

Figure 4 – ISO/R2 envelope dimensions for a reduced-size rearward-facing toddler CRS – ISOFIX SIZE CLASS D

4.5. Rearward-facing infant child restraint systems envelope



Key

- 1 Limits in the rearward and upward directions
- 2 Dashed line marks area where a support leg, or similar, is allowed to protrude
- 3 The backwards limitation (to the right in the figure) is given by the forward-facing envelope in Figure 2
- 4 Further specifications of the connector area is given in R44

Figure 5 – ISO/R1 envelope dimensions for an infant-size rearward-facing CRS – ISOFIX SIZE CLASS E

4.6. Lateral facing child restraint systems envelope

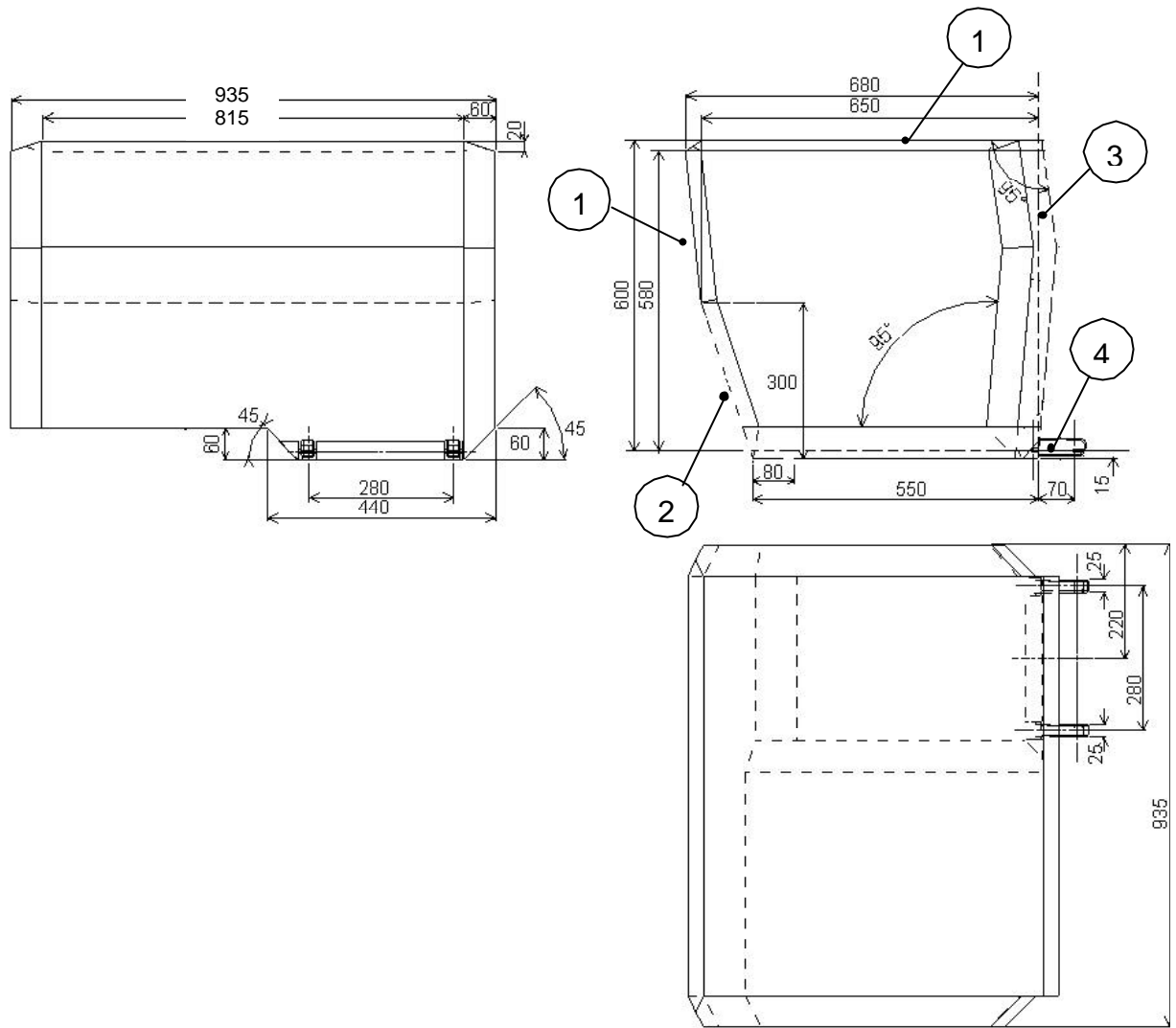

Key

1 Limits in the rearward and upward directions

2 Dashed line marks area where a support leg, or similar, is allowed to protrude

3 The backward limitation (to the right in the figure) is given by the forward facing envelope in Figure 2

4 Further specifications of the connector area is given in ISO 13216-1, Figures 2 and 3

Figure 6 — Envelope dimensions for Lateral facing position CRS – ISO/L1 – ISOFIX SIZE CLASS F or symmetrically opposite – ISO/L2 – ISOFIX SIZE CLASS G

Annex 17 – Appendix 2 (former), renumber as appendix 3, and

The table, amend to read:

"Table 1

TABLE OF VEHICLE HANDBOOK INFORMATION ON CHILD RESTRAINT SYSTEMS
INSTALLATION SUITABILITY FOR VARIOUS SEATING POSITIONS

Mass Group	Seating position (or other site)				
	Front Passenger	Rear Outboard	Rear Centre	Intermediate Outboard	Intermediate Centre
group 0 up to 10 kg					
group 0+ up to 13 kg					
group I 9 to 18 kg					
group II 15 to 25 kg					
group III 22 to 36 kg					

"

Insert a new table 2, to read:

"Table 2

TABLE OF VEHICLE HANDBOOK INFORMATION ON ISOFIX CHILD RESTRAINT SYSTEMS INSTALLATION SUITABILITY FOR VARIOUS ISOFIX POSITIONS

Mass Group	Size class	Fixture	Vehicle ISOFIX positions					
			Front Passenger	Rear Outboard	Rear Centre	Intermediate Outboard	Intermediate Centre	Others sites
carrycot	F	ISO/L1						
	G	ISO/L2						
		(1)						
group 0 up to 10 kg	E	ISO/R1						
		(1)						
group 0+ up to 13 kg	E	ISO/R1						
	D	ISO/R2						
	C	ISO/R3						
		(1)						
group I 9 to 18 kg	D	ISO/R2						
		ISO/R3						
	B	ISO/F2						
	A	ISO/F3						
		(1)						
group II 15 to 25 kg		(1)						
group III 22 to 36 kg		(1)						

- (1) For the CRS which do not carry the ISO/XX size class identification (A to G), for the applicable mass group, the car manufacturer shall indicate the vehicle specific ISOFIX child restraint system(s) recommended for each position.

Key of letters to be inserted in the above table

IUF = suitable for ISOFIX forward child restraints systems of universal category approved for use in the mass group

IL = suitable for particular ISOFIX child restraint systems (CRS) given in the attached list. These ISOFIX CRS are those of the "specific vehicle", "restricted" or "semi-universal" categories.

X = ISOFIX position not suitable for ISOFIX child restraint systems in this mass group and / or this size class."