

E/ECE/324

E/ECE/TRANS/505

} Rev.1/Add.51/Rev.2

8 July 2003

AGREEMENT

CONCERNING THE ADOPTION OF UNIFORM TECHNICAL PRESCRIPTIONS FOR WHEELED VEHICLES, EQUIPMENT AND PARTS WHICH CAN BE FITTED AND/OR BE USED ON WHEELED VEHICLES AND THE CONDITIONS FOR RECIPROCAL RECOGNITION OF APPROVALS GRANTED ON THE BASIS OF THESE PRESCRIPTIONS */

(Revision 2, including the amendments which entered into force on 16 October 1995)

Addendum 51: Regulation No. 52

Revision 2

Incorporating all valid text up to:

Supplement 1 to the 01 series of amendments - Date of entry into force: 3 January 1998

Supplement 2 to the 01 series of amendments - Date of entry into force: 29 December 2000

Supplement 3 to the 01 series of amendments - Date of entry into force: 21 February 2002 **/

Supplement 4 to the 01 series of amendments - Date of entry into force: 15 August 2002 ***/

Supplement 5 to the 01 series of amendments - Date of entry into force: 7 December 2002

Corrigendum 1 to Supplement 5 to the 01 series of amendments subject of Depository Notification C.N.35.2003.TREATIES-1 dated 17 January 2003

UNIFORM PROVISIONS CONCERNING THE APPROVAL OF M2 AND M3 SMALL CAPACITY VEHICLES WITH REGARD TO THEIR GENERAL CONSTRUCTION



UNITED NATIONS

*/ Former title of the Agreement:

Agreement Concerning the Adoption of Uniform Conditions of Approval and Reciprocal Recognition of Approval for Motor Vehicle Equipment and Parts, done at Geneva on 20 March 1958.

**/ For New Zealand the date of entry into force is 21 April 2001.

***/ For Ukraine, the date of entry into force is 15 October 2002.

UNIFORM PROVISIONS CONCERNING THE APPROVAL OF M₂ AND M₃
SMALL CAPACITY VEHICLES WITH REGARD TO THEIR GENERAL
CONSTRUCTION

CONTENTS

	Page
1. Scope	4
2. Definitions	4
3. Application for approval	7
4. Approval	8
5. Specifications	10
6. Modification and Extension of Approval of a type of vehicle	42
7. Conformity of production	43
8. Penalties for non-conformity of production	43
9. Production definitely discontinued	43
10. Transitional provisions	44
11. Names and addresses of technical services responsible for conducting approval tests, and of administrative departments	44

ANNEXES

Annex 1 - Communication concerning the approval or extension or refusal or withdrawal of approval or production definitely discontinued of a vehicle type with regard to its structural features, pursuant to Regulation No. 52

Annex 2 - Arrangements of approval marks

Annex 3 - Explanatory diagrams

Annex 4 - Guidelines for measuring the closing forces of power-operated doors

1. SCOPE

This Regulation applies to single-deck rigid vehicles of categories M₂ and M₃ 1/ designed and constructed for the carriage of seated or standing persons and having a capacity not exceeding 22 passengers in addition to the driver.

- 1.1. Technical provisions for the carriage of passengers with reduced mobility are outside of the scope of this Regulation. Until harmonized provisions for accessibility are finalized and included in an annex to this Regulation, Contracting Parties may apply additional requirements to ensure access to vehicles and the safety of such passengers.

2. DEFINITIONS

For the purposes of this Regulation:

- 2.1. "Vehicle" means a single-deck vehicle of category M₂ or M₃ 1/ designed and constructed for the carriage of seated, or seated and standing persons and having a capacity not exceeding 22 passengers in addition to the driver;

There are two classes of vehicles:

- 2.1.1. Class A: Vehicles designed to carry standing passengers; a vehicle of this class has seats and may have provision for standing passengers.

- 2.1.2. Class B: Vehicles not designed to carry standing passengers; a vehicle of this class has no provisions for standing passengers.

- 2.1.3. "Low floor vehicle" means a vehicle in which at least 35 per cent of the area available for standing passengers forms a single area without steps, reached through at least one service door by a single step from the ground.

- 2.2. "Vehicle type" means a category of vehicles which do not differ essentially with regard to the constructional features specified in this Regulation;

- 2.3. "Approval of a vehicle" means the approval of a vehicle type with regard to the constructional features specified in this Regulation;

1/ As defined in annex 7 of the Consolidated Resolution on the Construction of Vehicles (R.E.3) (document TRANS/WP.29/78/Rev.1/Amend.2).

- 2.4. "Service door" means a door used by passengers in normal circumstances with the driver seated;
- 2.5. "Double door" means a door affording two, or the equivalent of two, access passages;
- 2.6. "Emergency door" means a door additional to the service doors intended for use by passengers as an exit only exceptionally and, in particular, in an emergency;
- 2.7. "Emergency window" means a window, not necessarily glazed, intended for use as an exit by passengers in an emergency only;
- 2.8. "Double window" means an emergency window which, when divided into two by an imaginary vertical line (or plane), exhibits two parts each of which complies as to dimensions and access with the requirements applicable to a normal emergency window;
- 2.9. "Escape hatch" means a roof-opening intended for use as an exit by passengers in an emergency only;
- 2.10. "Emergency exit" means an emergency door, emergency window or escape hatch;
- 2.11. "Exit" means a service door or emergency exit;
- 2.12. "Sliding door" means a door, which can be opened or closed only by sliding it along one or more rectilinear or approximately rectilinear rails;
- 2.13. "Floor or deck" means that part of the bodywork whose upper surface supports standing passengers, the feet of seated passengers and of the driver, and seat mountings;
- 2.14. "Gangway" means the space providing access by passengers from any seat or row of seats to any other seat or row of seats or to any access passage from or to any service door; it does not include:
- 2.14.1. the space required to accommodate the feet of seated passengers;
- 2.14.2. the space above the surface of any step or staircase; or
- 2.14.3. any space which affords access solely to one seat or to one row of seats.

- 2.15. "Access passage" means the space extending inwards into the vehicle from the service door up to the outermost edge of the upper step (edge of the gangway). Where there is no step at the door, the space to be considered as access passage shall be that which is measured according to paragraph 5.7.1.1. up to a distance of 30 cm from the starting position of the inner face of the dual panel.
- 2.16. "Driver's compartment" means the space intended for the driver's exclusive use, except in emergency, and containing the steering wheel, controls, instruments and other devices necessary for driving the vehicle.
- 2.17. "Unladen kerb mass" (MK) (kg) means the mass of the vehicle in running order, unoccupied and unladen but with the addition of 75 kg for the mass of the driver, the mass of fuel corresponding to 90 per cent of the capacity of the fuel tank specified by the manufacturer, and the masses of coolant, lubricant, tools and spare wheel, if any;
- 2.17.1. "Unladen mass" (MV) (kg) means the unladen kerb mass (MK) (kg) of the vehicle as defined in paragraph 2.17., with the addition of 75 kg for the mass of the crew member corresponding to the seat, if any, specially assigned to this crew member as described in paragraph 5.7.1.8. The vehicle shall be complete with 90 per cent of the capacity of all additional liquid tanks (e.g. fuel for combustion heaters, screen washers, etc.). Where facilities such as a kitchen or toilet are fitted, the fresh water tanks shall be full and the waste tanks empty.
- 2.18. "Technical maximum mass" means the technically permissible maximum mass declared by the manufacturer of the vehicle. (This mass may be greater than the "permissible maximum mass" to be prescribed by national administrations).
- 2.19. "Technically permissible maximum axle mass" means that part of the technically permissible maximum mass of the vehicle, declared by the manufacturer, which results in the vertical force at the road surface in the contact area on the wheel/wheels of an axle. This mass may be greater than the maximum permissible axle mass authorized by national administrations.
- The sum of all technically permissible maximum axle masses of the vehicle may be greater than the technically permissible maximum mass of that vehicle.
- 2.20. "Passenger" means a person other than the driver or a member of the crew;
- 2.20.1. "Passenger with reduced mobility" means all passengers who have a special difficulty when using public transport, especially elderly and disabled people. Reduced mobility does not necessarily imply any form of medical impairment.

- 2.21. "Passenger compartment" means the space intended for passengers use excluding any space occupied by fixed appliances such as bars, kitchenettes or toilets or luggage compartment;
- 2.22. "Automatically operated service door" means a power-operated service door which can be opened (other than by means of emergency controls) only after a control is operated by a passenger, and after activation of the controls by the driver, and which closes again automatically;
- 2.23. "Starting prevention device" means a device which prevents the vehicle being driven away from rest when a door is not fully closed;
- 2.24. "Driver operated service door" means a service door which normally is opened and closed by the driver.
- 2.25. Unless otherwise stated, all measurements shall be made when the vehicle is at its unladen kerb mass (MK) (kg) and it is standing on a smooth and horizontal ground surface. If a kneeling system is fitted to the vehicle, it shall not be in operation.
- 2.26. Wherever there is a requirement in this Regulation for a surface in the vehicle to be horizontal or at a specific angle when the vehicle is at its unladen kerb mass (MK) (kg), in the case of a vehicle with mechanical suspension, the surface may exceed this slope or possess a slope when the vehicle is at its unladen kerb mass (MK) (kg), provided that this requirement is met when the vehicle is in the loading condition declared by the manufacturer. If a kneeling system is fitted to the vehicle, it shall not be in operation.
3. APPLICATION FOR APPROVAL
- 3.1. The application for approval of a vehicle type with regard to its constructional features shall be submitted by the vehicle manufacturer or by his duly accredited representative.
- 3.2. It shall be accompanied by the undermentioned documents in triplicate and by the following particulars:
- 3.2.1. a detailed description of the vehicle type with respect to its structure, dimensions, configuration and constituent materials;
- 3.2.2. drawings of the vehicle and its interior arrangements; and
- 3.2.3. particulars of

- 3.2.3.1. the technical maximum mass (MT) (kg);
- 3.2.3.2. the technical maximum load for each axle (kg);
- 3.2.3.3. the unladen mass of the vehicle MV (kg);
- 3.2.4. provision made, if any, for the carriage of baggage or goods;
- 3.2.5. where one or more baggage compartments have been provided for baggage other than hand baggage, the total volume of such compartments (V) (m³) and the total mass of the baggage that they can obtain (B) (kg);
- 3.2.6. where the vehicle is equipped to carry baggage on the roof, the total surface area available for such baggage (VX) (m²) and the total mass of baggage that can be placed on it (BX) (kg);
- 3.2.7. the horizontal projection of the total surface area intended for seated and standing passengers (S_o)(m²);
- 3.2.8. the horizontal projection of the total surface area intended for standing passengers (S₁)(m₂) in accordance with paragraph 5.2.;
- 3.2.9. the number of seating places intended for use by passengers and crew (if any). Sleeping places and other accommodations which are intended to be temporarily used instead of a seating place shall not count as seating places.
- 3.2.10. the intended total number of passengers (N);
- 3.2.11. the class (A or B) for which the approval is requested.
- 3.3. A vehicle representative of the type to be approved shall be submitted to the technical service responsible for conducting the approval tests.

4. APPROVAL

- 4.1. If the vehicle submitted for approval pursuant to this Regulation meets the requirements of paragraph 5 below, approval of that vehicle type shall be granted.
- 4.2. An approval number shall be assigned to each type approved. Its first two digits (at present 01 corresponding to the 01 series of amendments which entered into force on 12 September 1995) shall indicate the series of amendments incorporating the most recent major technical amendments made to the

Regulation at the time of issue of the approval. The same Contracting Party shall not assign the same number to another vehicle type.

- 4.3. Notice of approval or of extension or refusal of approval of a vehicle type pursuant to this Regulation shall be communicated to the Parties to the Agreement which apply this Regulation by means of a form conforming to the model in annex 1 to this Regulation.
- 4.4. There shall be affixed, conspicuously and in a readily accessible place specified on the approval form, to every vehicle conforming to a vehicle type approved under this Regulation an international approval mark consisting of:
- 4.4.1. a circle surrounding the letter "E" followed by the distinguishing number of the country which has granted approval; 2/
- 4.4.2. the number of this Regulation, followed by the letter "R", a dash and the approval number to the right of the circle prescribed in paragraph 4.4.1.; and
- 4.4.3. an additional symbol consisting of the letter A or B indicating the Class in which the vehicle has been approved.
- 4.5. If the vehicle conforms to a vehicle type approved under one or more other Regulations annexed to the Agreement, in the country which has granted approval under this Regulation, the symbol prescribed in paragraph 4.4.1. need not be repeated; in such a case, the regulation and approval numbers and the

2/ 1 for Germany, 2 for France, 3 for Italy, 4 for the Netherlands, 5 for Sweden, 6 for Belgium, 7 for Hungary, 8 for the Czech Republic, 9 for Spain, 10 for Serbia and Montenegro, 11 for the United Kingdom, 12 for Austria, 13 for Luxembourg, 14 for Switzerland, 15 (vacant), 16 for Norway, 17 for Finland, 18 for Denmark, 19 for Romania, 20 for Poland, 21 for Portugal, 22 for the Russian Federation, 23 for Greece, 24 Ireland, 25 for Croatia, 26 for Slovenia, 27 for Slovakia, 28 for Belarus, 29 for Estonia, 30 (vacant), 31 for Bosnia and Herzegovina, 32 for Latvia, 33 (vacant), 34 for Bulgaria, 35 (vacant), 36 for Lithuania, 37 for Turkey, 38 (vacant), 39 Azerbaijan, 40 for The former Yugoslav Republic of Macedonia, 41 (vacant), 42 for the European Community (Approvals are granted by its Member States using their respective ECE symbol), 43 for Japan, 44 (vacant), 45 for Australia, 46 for Ukraine, 47 for South Africa and 48 for New Zealand. Subsequent numbers shall be assigned to other countries in the chronological order in which they ratify or accede to the Agreement Concerning the Adoption of Uniform Technical Prescriptions for Wheeled Vehicles, Equipment and Parts which can be Fitted and/or be Used on Wheeled Vehicles and the Conditions for Reciprocal Recognition of Approvals Granted on the Basis of these Prescriptions, and the numbers thus assigned shall be communicated by the Secretary-General of the United Nations to the Contracting Parties to the Agreement.

additional symbols of all the Regulations under which approval has been granted in the country which has granted approval under this Regulation shall be placed in vertical columns to the right of the symbol prescribed in paragraph 4.4.1.

- 4.6. The approval mark shall be clearly legible and be indelible.
- 4.7. The approval mark shall be placed close to or on the vehicle data plate affixed by the manufacturer.
- 4.8. Annex 2 to this Regulation gives examples of arrangements of approval marks.

5. SPECIFICATIONS

5.1. Load distribution between axles and loading conditions

5.1.1. The load distribution of a stationary vehicle on level ground shall be determined in two conditions:

5.1.1.1. unladen, as specified in paragraph 5.1.3., and

5.1.1.2. laden, as specified in paragraph 5.1.4.

5.1.2. The front axle (or axles) shall carry not less than the percentage of mass shown in the table below:

Loading Conditions	Class A	Class B
Unladen	20	25
Laden	25	25

5.1.3. Unladen, for the purpose of this paragraph (5.1.) and paragraph 5.3., means the vehicle in the condition described in paragraph 2.17.1.

5.1.4. Laden, for the purpose of this paragraph (5.1.), means the vehicle unladen as described in paragraph 5.1.3. with the addition of a mass Q on each passenger seat, a number, corresponding to the authorized number of standing passengers, of mass Q uniformly distributed over the area S_1 , a mass equal to B uniformly distributed in the baggage compartments and, where appropriate, a mass equal to BX uniformly distributed over the surface area of the roof equipped for the carriage of baggage (MT) (kg).

- 5.1.5. The values of Q for the different classes of vehicles are specified in paragraph 5.3.2.
- 5.1.6. B (kg) shall have a numerical value not less than $100 V$ (m^3).
- 5.1.7. BX shall exert a pressure of not less than 75 kg/m^2 over the whole surface area of the roof equipped for the carriage of baggage.
- 5.2. Area available for passengers
- 5.2.1. The total surface area S_o available for passengers is calculated by deducting from the total area of the vehicle:
- 5.2.1.1. the area of the driver's compartment;
- 5.2.1.2. the area of steps at doors and the area of any step with a depth of less than 30 cm;
- 5.2.1.3. the area of any part over which the vertical clearance is less than 135 cm measured from the floor, according to paragraph 5.7.8. and disregarding intrusions permitted. In the case of vehicles to which paragraph 5.7.1.9. applies, this dimension may be reduced to 120 cm.
- 5.2.2. The surface area S_1 available for standing passengers (only in the case of class A vehicles) is calculated by deducting from S_o :
- 5.2.2.1. the area of all parts of the floor in which the slope exceeds 8 per cent;
- 5.2.2.2. the area of all parts which are not accessible to a standing passenger when all the seats are occupied; with the exception of folding seats;
- 5.2.2.3. the area of all parts where the clear height above the floor is less than 190 cm or in the case of the section of the gangway situated above and behind the rear axle, and the attaching parts thereof - less than 180 cm (handholds shall not be taken into account in this connection);
- 5.2.2.4. the area forward of a vertical plane passing through the centre of the seating surface of the driver's seat (in its rearmost position) and through the centre of the exterior rear-view mirror mounted on the opposite side of the vehicle; and
- 5.2.2.5. the area 30 cm in front of all seats other than folding seats;

5.2.2.6. any surface not being excluded by the provisions in paragraphs 5.2.2.1. to 5.2.2.5. above, on which it is not possible to place a rectangle of 400 mm x 300 mm.

5.3. Passenger capacity

5.3.1. There shall be on the vehicle a number (P_s) of seating places (see paragraph 3.2.9. above), other than folding seats, which conform to the requirements of paragraph 5.7.8. For a vehicle of Class A the number P_s shall be at least equal to the number of square metres of floor available for passengers and crew (if any) (S_o) rounded down to the nearest whole number.

5.3.2. The total number N of seating and standing places in vehicles shall be calculated such that both of the following conditions are fulfilled:

$$N = P_s + \frac{S_1}{S_{sp}}$$

and

$$N \leq \frac{MT - MV - L \cdot V - R \cdot VX}{Q}$$

where:

- P_s = Number of seating places (see paragraphs 3.2.9. and 5.3.1.);
- S_1 = Surface area (m²) (see paragraph 5.2.2.) available for standing passengers;
- S_{sp} = Area assumed for one standing passenger (m²/standing passenger) (see paragraph 5.3.2.2.);
- MT = Technically permissible maximum mass (kg) (see paragraph 2.18.);
- MV = Unladen mass (kg) as defined in paragraph 2.17.1.;
- L = Specific load of baggage (kg/m³) in the baggage compartment(s);
- V = Total volume (m³) of the baggage compartments (see paragraph 3.2.5.);
- R = Specific mass of baggage in the roof area (kg/m²);
- VX = Total surface area (m²) available for baggage to be carried on the roof (see paragraph 3.2.6.);
- Q = Mass (kg) assumed for the load on each passenger seating and standing place, if any (see paragraph 5.3.2.2.).

5.3.2.1. In vehicles of Class B, $S_1 = 0$.

5.3.2.2. The values of Q, S_{sp}, L and R for both classes of vehicles are as follows:

Class	Q (kg)	S _{sp} (m ² /standing passenger)	L (kg/m ³)	R (kg/m ²)
A	68	0,125	100	75
B	71 <u>*/</u>	(no standing passengers)	100	75

*/ Including 3 kg of hand baggage.

5.3.2.3. If a vehicle of Class B is approved as a Class A vehicle, the mass of baggage carried in the baggage compartments accessible only from outside the vehicle is not taken into account.

5.3.3. When calculated according to paragraph 5.3.2., the mass on each axle of the vehicle shall not exceed the values of their respective technically permissible maximum values.

5.3.4. The vehicle shall be clearly marked in a manner visible on the inside in the vicinity of the front door in letters or pictograms not less than 15 mm high and numbers not less than 25 mm high, with

5.3.4.1. the number of seating places for which the vehicle is designed (Ps);

5.3.4.2. the total number of passengers for which the vehicle is designed (N);

5.3.4.3. the number of wheelchairs, if any, for which the vehicle is designed.

5.4. Strength of the superstructure

In the case of class B vehicles only, it must be shown by calculation or by any other suitable method that the structure of the vehicle is strong enough to withstand an evenly-distributed static load on the roof equal to the technical maximum mass (MT) of the vehicle. 3/

3/ This paragraph will be reconsidered when Regulation No. 66 is next amended.

5.5. Protection against fire risks

5.5.1. Engine compartment

5.5.1.1. No inflammable soundproofing material or material liable to become impregnated with fuel or lubricant shall be used in the engine compartment unless the material is covered by an impermeable sheet.

5.5.1.2. Precautions shall be taken, either by a suitable layout of the engine compartment or by the provision of drainage orifices, to avoid so far as possible the accumulation of fuel or lubricating oil in any part of the engine compartment.

5.5.1.3. A barrier of heat-resisting material shall be fitted between the engine compartment or any other source of heat (such as a device designed to absorb the energy liberated when a vehicle is descending a long gradient, e.g. a retarder or a device for heating the interior of the body other, however, than a device functioning by warm water circulation) and the rest of the vehicle. A heating device operating other than by hot water may be provided in the passenger compartment if it is encased in material designed to resist the temperatures generated by the device, emits no toxic fumes and is positioned such that no passenger is likely to come into contact with any hot surface.

5.5.2. Fuel filler-holes

5.5.2.1. Fuel filler-holes shall be accessible only from outside the vehicle.

5.5.2.2. Fuel filler-holes shall not be underneath a door aperture; they shall moreover, not be in the passenger compartment or the driver's compartment. Fuel filler-holes shall not be located such that there is a risk of fuel falling onto the engine or exhaust system during fillings.

5.5.2.3. The fuel shall not be able to run out through the filler-hole cap or through the devices provided to stabilize the pressure in the tank, even if the tank is completely overturned; slight drip shall however be tolerated if it does not exceed 30 g/min. If the vehicle is fitted with several interconnected fuel tanks, the pressure during the test shall correspond to the most unfavourable position for the fuel tanks.

5.5.2.4. If the filler-hole is situated on a side of the vehicle, the cap shall, when closed, not project beyond the adjacent surfaces of the bodywork.

5.5.2.5. Fuel filler-hole caps shall be so designed and constructed that they cannot be opened accidentally.

5.5.3. Fuel tanks

- 5.5.3.1. All of the vehicle's fuel tanks shall be securely fixed and so situated as to be protected by the structure of the vehicle in the event of a frontal or rear collision. No part of a fuel tank shall be less than 60 cm from the front and less than 30 cm from the rear of the vehicle unless the vehicle has successfully complied with the frontal-impact and the rear-end impact requirement of Regulation No. 34; there shall be no protruding parts, sharp edges, etc., near the tanks.
- 5.5.3.2. No part of a fuel tank shall project beyond the overall width of the bodywork.
- 5.5.3.3. Fuel tanks must be made so as to be corrosion resistant.
- 5.5.3.4. Any excess pressure or any pressure exceeding the working pressure shall be automatically compensated by suitable devices (vents, safety valves, etc.). The vents shall be designed in such a way as to prevent any fire risks.
- 5.5.3.5. All tanks shall be subjected to a hydraulic internal-pressure test, which shall be carried out on an isolated unit complete with standard filler-pipe, filler-neck and cap. The tank shall be completely filled with water. After all communication with the outside has been cut off, the pressure shall be gradually increased, through the pipe connection through which fuel is fed to the engine, to a relative pressure which is double the service pressure, but not less than 0.3 bar, which shall be maintained for one minute. During this time the tank shell shall not crack or leak; it may, however, be permanently distorted.

5.5.4. Fuel-feed systems

- 5.5.4.1. No apparatus used for the fuel feed shall be placed in the driver's compartment or the passenger compartment.
- 5.5.4.2. Fuel lines and all other parts of the fuel-feed system shall be accommodated in positions on the vehicle where they have the fullest reasonable protection.
- 5.5.4.3. Twisting or bending movements and vibration of the vehicle structure or the power unit shall not subject the fuel lines to abnormal stress.
- 5.5.4.4. The unions of pliable or flexible pipes with rigid parts of the fuel-feed system shall be so designed and constructed as to remain leakproof in the various conditions of use of the vehicle, despite aging, twisting or bending movements, or vibration of the vehicle structure or the power unit.

5.5.4.5. Fuel leaking from any part of the system shall be able to flow away freely to the road surface, but never onto the exhaust system.

5.5.5. Emergency switch, if fitted

If an emergency switch is fitted to reduce the risk of fire after the vehicle has come to a standstill, this emergency switch shall have the following characteristics:

5.5.5.1. It shall be located within immediate reach of the driver seated in the driver's seat;

5.5.5.2. It shall be clearly marked and be provided with a protective cover or other suitable means to prevent inadvertent operation. Clear instructions concerning the method of operation shall be displayed in the immediate vicinity of the emergency switch, e.g. "Remove cover and move lever downwards! Actuate only when the vehicle has been brought to a stop";

5.5.5.3. Its actuation shall cause simultaneous performance of the following functions:

5.5.5.3.1. quick stoppage of the engine;

5.5.5.3.2. operation of a battery isolating switch, fitted as close to the batteries as possible, and which isolates at least one battery terminal from the electrical circuit, with the exception of the circuit permitting the function required by paragraph 5.5.5.3.3. below, the circuits which ensure the uninterrupted function of the tachograph as well as those devices whose sudden removal from service could provoke a greater risk than the one avoided, for example:

5.5.5.3.2.1. emergency interior lighting;

5.5.5.3.2.2. cooling scavenger of auxiliary heaters;

5.5.5.3.2.3. centralized electronic door locking.

5.5.5.3.3. Switching-on of the vehicle's hazard warning signal.

5.5.5.4. Performance of the functions mentioned in paragraph 5.5.5.3. above may be initiated not only by the emergency switch, but also by separate controls, provided that these do not in an emergency interfere with the functioning of the emergency switch.

5.5.6. Electrical equipment and wiring

5.5.6.1. All cables shall be well insulated and all cables and electrical equipment shall be able to withstand the temperature and humidity conditions to which they are exposed. In the engine compartment,

particular attention shall be paid to their suitability to withstand the environmental temperature, oil and vapour.

5.5.6.2. No cable used in an electrical circuit shall carry a current in excess of that acceptable for such a cable in the light of its mode of installation and the maximum ambient temperature.

5.5.6.3. Every electrical circuit feeding an item of equipment other than the starter, the ignition circuit (positive ignition), the glow-plugs, the engine-stopping device, the charging circuit and the battery earth connection shall include a fuse or a circuit breaker. Circuits feeding low consumption equipment may, however, be protected by a common fuse or a common circuit-breaker, provided that its rated capacity does not exceed 16 A. In the case where electronics are incorporated, these circuits may be protected by protection devices integrated into the electronic components or systems. In such a case, the manufacturer shall give all the relevant technical information at the request of the technical service responsible for conducting the tests.

5.5.6.4. All cables shall be suitably protected and shall be held securely in position in such a way that they cannot be damaged by cutting, abrasion or chafing.

5.5.7. Batteries

5.5.7.1. All batteries shall be well secured and easily accessible.

5.5.7.2. The battery compartment shall be separated from the passenger compartment and the driver's compartment and ventilated to outside air.

5.5.8. Fire extinguishers and first-aid equipment

5.5.8.1. The vehicle shall be fitted with one or more fire extinguishers, one being near the driver's seat. Each extinguisher shall have a minimum test rating of 8A or 21B to CEN Standard EN3 Part 1 or an equivalent national standard.

5.5.8.2. Space shall be provided for the fitting of one or more first-aid kits. The space provided shall not be less than 7 dm³, the minimum dimension shall not be less than 80 mm.

5.5.8.3. Fire extinguishers and first aid kits may be secured against theft or vandalism (e.g. in an internal locker or behind breakable glass), provided that the locations of these items are clearly marked and means are provided for persons to easily extract them in an emergency.

5.5.9. Materials

No flammable material shall be permitted within 10 cm of the exhaust pipe unless the material is effectively shielded.

5.6. Exits

5.6.1. Number

5.6.1.1. Every vehicle shall have at least two doors, i.e. either one service door and one emergency door or two service doors.

5.6.1.2. For the purpose of this requirement, service doors equipped with a power-operated control system shall not be deemed to be exits unless they can be readily opened by hand once the control prescribed in paragraph 5.6.5.1. has been actuated, if necessary.

5.6.1.3. The minimum number of emergency exits shall be such that the total number of exits and of escape hatches is as follows:

Number of passengers	Minimum number of exits	Number of escape hatches counted as emergency exits	
		permitted	required
# 16	3	1	
> 16	4		1

5.6.1.4. Where the driver's compartment does not communicate with the inside of the vehicle it shall have two exits, which shall not both be in the same lateral walls; where one of the exits is a window it shall comply with the requirements set out in paragraphs 5.6.3.1., 5.6.8.1. and 5.6.8.2. for emergency windows.

5.6.1.5. A double service door shall count as two doors and a double window as two emergency windows.

5.6.2. Siting of exits

- 5.6.2.1. The service door(s) shall be situated on the side of the vehicle that is nearer to the side of the road corresponding to the direction of traffic, 4/ or in the rear face of the vehicle.
- 5.6.2.2. The exits shall be placed in such a way that there is at least one exit on each side of the vehicle.
- 5.6.2.3. The forward half and the rearward half of the passenger space shall each contain at least one exit.
- 5.6.2.4. At least one exit shall be situated either in the rear face or in the front face of the vehicle unless an escape hatch is fitted in the roof.
- 5.6.2.5. If the space reserved for the driver's seat and the passenger's seats beside the driver's seat does not communicate with the main passengers' compartment by means of a suitable passageway
- 5.6.2.5.1. the main compartment reserved for passengers shall contain exits satisfying the requirement of paragraph 5.6.1 with respect to number and those of paragraphs 5.6.2.1., 5.6.2.2. and 5.6.2.3. above with respect to siting;
- 5.6.2.5.2. the driver's door shall be accepted as the emergency door for the occupants of the seats situated beside the driver's seat provided that the driver's seat, the steering wheel, the engine housing, the gear lever and handbrake control, etc., do not constitute too great an obstruction. 5/ The service door provided for the passengers shall be in the side of the vehicle opposite to that containing the driver's door and shall be accepted as the emergency door for the driver;
- 5.6.2.5.3. the doors referred to in paragraph 5.6.2.5.2. shall not be subject to the requirements of paragraphs 5.6.3., 5.7.1., 5.7.2., 5.7.7. and 5.10.1.

5.6.3. Minimum dimensions

- 5.6.3.1. The several kinds of exits shall have the following minimum dimensions: (see also annex 3, figure 17):

4/ In the country in which the vehicle is licensed for operation.

5/ An objective method of verifying that this requirement is satisfied may be established for the use of testing laboratories.

Aperture	Dimensions	Remarks
Service door	<u>Entry height:</u> Class A - 165 cm Class B - 150 cm	The service door entry height shall be measured as the vertical distance, measured on a vertical plane of the horizontal projections of the mid point of the door aperture and the top surface of the lowest step.
	Aperture height	The vertical height of the service door aperture shall be such as to permit the free passage of the dual panel referred to in paragraph 5.7.1.1. The height at the upper corners may be reduced with round-offs, with a radius of not more than 15 cm.
	<u>Width:</u> Single door: 65 cm Double door: 120 cm	For vehicles of class B where the service door aperture height lies between 140 and 150 cm a minimum single door aperture width of 75 cm shall apply. For all the vehicles the width of any service door may be reduced by 10 cm when the measurement is made at the level of the hand-holds and by 25 cm in cases where intruding wheel arches or the actuating mechanism for automatic or remote-control doors or the rake of the windscreen so require.
Emergency door	Height: 125 cm Width: 55 cm	The width may be reduced to 30 cm in cases where intruding wheel arches so require, providing that the width of 55 cm is respected at the minimum height of 40 cm above the lowest part of the door aperture. The height at the upper corners may be reduced with round-offs, with a radius of not more than 15 cm.
Emergency window	Aperture area: 4,000 cm ²	It shall be possible to inscribe in this area a rectangle 50 cm high and 70 cm wide. A 5 per cent tolerance shall, however, be permitted in respect of this area for type approvals issued for one year following the entry into force of this Regulation.
		Emergency window situated in the rear face of the vehicle if the manufacturer does not provide an emergency window of the minimum dimensions prescribed above
Escape hatch	Aperture area: 4,000 cm ²	It shall be possible to inscribe in this area a rectangle measuring 50 x 70 cm.

5.6.3.2. A vehicle to which paragraph 5.7.1.9. applies shall meet the requirements of paragraph 5.6.3.1. above in respect of emergency windows and escape hatches, and the following requirements in respect of service doors and emergency doors:

Aperture	Dimensions	Remarks
Service door	Aperture height: 110 cm	This dimension may be reduced by a radius at the corners of the aperture not exceeding 15 cm radius.
	Width: Single door: 65 cm Double door: 120 cm	This dimension may be reduced by a radius at the corners of the aperture not exceeding 15 cm radius. The width may be reduced by 10 cm when the measurement is made at the level of the hand-holds and by 25 cm in cases where intruding wheel arches or the actuating mechanism for automatic or remote-control doors or the rake of the windscreen so require.
Emergency door	Height: 110 cm Width: 55 cm	The width may be reduced to 30 cm in cases where intruding wheel arches so require, providing that the width of 55 cm is respected at the minimum height of 40 cm above the lowest part of the door aperture. The height and width at the upper corners may be reduced with round-offs, with a radius of not more than 15 cm.

5.6.4. Technical conditions for the all service doors

5.6.4.1. Every service door shall be capable of being easily opened from inside and from outside the vehicle when the vehicle is stationary (but not necessarily when the vehicle is moving). However, this requirement shall not be construed as precluding the possibility of locking the door from outside, provided that the door can always be opened from inside.

5.6.4.2. Every control or device for opening a service door from the outside shall not be more than 180 cm above the ground when the vehicle is standing unladen on a level surface.

- 5.6.4.3. Every one-piece manually-operated service door which is hinged or pivoted shall be so hinged or pivoted that if the open door comes into contact with a stationary object while the vehicle is moving forwards it tends to close.
- 5.6.4.4. If a manually-operated service door is fitted with a slam lock it shall be of the two-stage type.
- 5.6.4.5. On the inside of a service door there shall not be any device intended to cover the inside steps when the door is closed.
- 5.6.4.6. If the direct view is not adequate, optical or other devices shall be installed to enable the driver to detect from his seat the presence of a passenger in the immediate interior and exterior vicinity of every service door which is not an automatically-operated service door.
- 5.6.4.7. Every door which opens towards the interior of the vehicle shall be so constructed that its movement is not likely to cause injury to passengers in normal conditions of use. Where necessary, appropriate protection devices shall be fitted.
- 5.6.4.8. If a service door is located adjacent to a toilet door or a door to another internal compartment the service door shall be proofed against an unintentional operation. However, this requirement shall not apply if the service door is locked automatically when the vehicle is moving at a speed exceeding 5 km/h.
- 5.6.4.9. On service doors which are in the rear face of the vehicle, the leaves shall not be capable of being opened more than 115° nor less than 85° and, when open, shall be capable of being held automatically in that position. This does not preclude the ability to override that stop and open the door beyond that angle when it is safe to do so; for example, to enable reversing against a high platform for loading or to open the doors through 270° to allow a clear loading area behind the vehicle.
- 5.6.4.10. The service door in any open position shall not obstruct the use of or required access to any mandatory exit.
- 5.6.5. Additional technical requirements for power-operated service doors
- 5.6.5.1. In the event of the emergency every power-operated service door shall be capable, when the vehicle is stationary (but not necessarily when the vehicle is moving), of being opened from inside and, when not locked, from outside by controls which, whether or not the power supply is operating:

- 5.6.5.1.1. override all other controls;
- 5.6.5.1.2. in the case of interior controls, are placed on, or within 300 mm of, the door, at a height of not less than 1,600 mm above the first step;
- 5.6.5.1.3. can be easily seen and clearly identified when approaching the door and when standing in front of the door;
- 5.6.5.1.4. can be operated by one person when standing immediately in front of the door;
- 5.6.5.1.5. cause the door to open, or enable the door to be easily opened by hand;
- 5.6.5.1.6. may be protected by a device which can be easily removed or broken to gain access to the emergency control; the operation of the emergency control, or the removal of a protective cover over the control, shall be indicated to the driver both audibly and visually, and
- 5.6.5.1.7. in the case of a driver-operated door which does not comply with the requirements of paragraph 5.6.5.6.2. shall be such that after they have been operated to open the door and returned to their normal position the doors will not close again until the driver subsequently operates a closing control.
- 5.6.5.2. A device may be provided which is operated by the driver from his seat to deactivate the outside emergency controls in order to lock the service doors from outside. In this case, the outside emergency controls shall be reactivated automatically either by the starting of the engine or before the vehicle reaches a speed of 20 km/h. Subsequently, deactivation of the outside emergency controls shall not occur automatically, but shall require a further action by the driver.
- 5.6.5.3. Every driver-operated service door shall be capable of operation by the driver when in the driving seat using controls which, except in the case of a foot control, are clearly and distinctively marked.
- 5.6.5.4. Every power-operated service door shall activate a visual tell-tale, which shall be plainly visible to the driver when seated in the normal driving position in any ambient lighting condition, to warn that a door is not fully closed. This tell-tale shall signal whenever the rigid structure of the door is between the fully open position and a point 30 mm from the fully closed position. One tell-tale may serve for one or more doors. However, no such tell-tale shall be fitted in respect of a front service door which does not comply with the requirements of paragraphs 5.6.5.6.2. and 5.6.5.6.3.

- 5.6.5.5. Where controls are provided for the driver to open and close a power-operated service door, they shall be such that the driver

is able to reverse the movement of the door at any time during the closing or opening process.
- 5.6.5.6. The construction and control system of every power-operated service door shall be such that a passenger is unlikely to be injured by the door or trapped in the door as it closes.
- 5.6.5.6.1. Except in the case of the front service door, this requirement shall be considered satisfied if the following two requirements are met:
- 5.6.5.6.2. The first requirement is that when the closing of the door at any measuring point described in annex 4 to this Regulation is resisted by a clamping force not exceeding 150 N, the door shall reopen automatically to its fullest extent and, except in the case of an automatically-operated service door, remain open until a closing control is operated. The clamping force may be measured by any method to the satisfaction of the competent authority. Guidelines are given in annex 4 to this Regulation. The peak force may be higher than 150 N for a short time provided that it does not exceed 300 N. The reopening system may be checked by means of a test bar having a section of height 60 mm, width 30 mm with corners radiused to 5 mm.
- 5.6.5.6.3. The second requirement is that whenever the doors are closed onto the wrist or fingers of a passenger:
- 5.6.5.6.3.1. the door reopens automatically to its fullest extent and, except in the case of an automatically-operated service door, remains open until a closing control is operated, or
- 5.6.5.6.3.2. the wrist or fingers can be readily extracted from the doors without risk of injury to the passenger. This requirement may be checked by hand, or by means of the test bar mentioned in paragraph 5.6.5.6.2., tapered at one end over a length of 300 mm from a thickness of 30 mm to a thickness of 5 mm. It shall not be treated with polish nor lubricated. If the door traps the bar it shall be capable of being easily removed, or
- 5.6.5.6.3.3. the door is maintained at a position allowing the free passage of a test bar having a section of height 60 mm, width 20 mm with corners radiused to 5 mm. This position shall not be more than 30 mm distant from the fully closed position.

- 5.6.5.6.4. In the case of a front service door the requirement of paragraph 5.6.5.6. shall be considered satisfied if the door:
- 5.6.5.6.4.1. fulfils the requirements of paragraphs 5.6.5.6.2. and 5.6.5.6.3., or
- 5.6.5.6.4.2. is fitted with soft edges; these shall not, however be so soft that if the doors are closed onto the test bar mentioned in paragraph 5.6.5.6.2. the rigid structure of the doors will reach the fully closed position.
- 5.6.5.7. Where a power-operated service door is held closed only by the continued application of the power supply there shall be provided a visual warning device to inform the driver of any failure in the power supply to the doors.
- 5.6.5.8. A starting prevention device, if fitted, shall be effective only at speeds of less than 5 km/h and shall be incapable of operation above that speed.
- 5.6.5.9. An audible warning to the driver may be activated if the vehicle is driven away from rest when any power-operated service door is not fully closed. This audible warning shall be activated at a speed exceeding 5 km/h for doors complying with the requirements of paragraph 5.6.5.6.3.3.
- 5.6.6. Additional technical requirements for automatically-operated service doors
- 5.6.6.1. Activation of the opening controls
- 5.6.6.1.1. Except as provided in paragraph 5.6.5.1., the opening controls of every automatically-operated service door shall be capable of being activated and deactivated only by the driver from his seat.
- 5.6.6.1.2. Activation and deactivation may be either direct, by means of a switch, or indirect, for example by opening and closing the front service door.
- 5.6.6.1.3. Activation of the opening controls by the driver shall be indicated inside and, where a door is to be opened from outside, also on the outside of the vehicle; the indicator (e.g. illuminated push button, illuminated sign) shall be on or adjacent to the door to which it relates.
- 5.6.6.1.4. In the case of direct actuation by means of a switch the functional state of the system shall be clearly indicated to the driver, for example by the position of a switch or an indicator lamp or an illuminated switch. The switch shall be specially marked and arranged in such a way that it cannot be confused with other controls.

5.6.6.2. Opening of automatically-operated service doors

5.6.6.2.1. After activation of the opening controls by the driver it shall be possible for passengers to open the door as follows:

5.6.6.2.1.1. from inside, for example by pressing a push button or passing a light barrier, and

5.6.6.2.1.2. from outside, except in the case of a door intended only for use as an exit and marked as such, for example by pressing an illuminated push button, a push button beneath an illuminated sign, or a similar device marked with a suitable instruction.

5.6.6.2.2. The pressing of the push buttons mentioned in paragraph 5.6.6.2.1.1. may send a signal which is stored and which, after the activation of the opening controls by the driver, effects the opening of the door.

5.6.6.3 Closing of automatically-operated service doors

5.6.6.3.1. When an automatically-operated service door has opened it shall close again automatically after a time interval has elapsed. If a passenger enters or leaves the vehicle during this time interval, a safety device (e.g. a footboard contact, light barrier, one-way gate) shall ensure that the time until the door closes is sufficiently extended.

5.6.6.3.2. If a passenger enters or leaves the vehicle while the door is closing, the closing process shall be interrupted automatically and the door shall return to the open position. The reversal may be actuated by one of the devices referred to in paragraph 5.6.6.3.1. or by any other device.

5.6.6.3.3. A door that has closed automatically in accordance with paragraph 5.6.6.3.1. shall be capable of being opened again by a passenger in accordance with paragraph 5.6.6.2.; this shall not apply if the driver has deactivated the opening controls.

5.6.6.3.4. After deactivation of the opening controls of the automatically-operated service doors by the driver, open doors shall close in accordance with paragraphs 5.6.6.3.1. to 5.6.6.3.3.

5.6.6.4. Inhibition of the automatic closing process on doors marked for special service, e.g. for passengers with prams, disabled persons, etc.

- 5.6.6.4.1. The driver shall be able to inhibit the automatic closing process by actuation of a special control. A passenger shall also be able to inhibit the automatic closing process directly by pressing a special push button.
- 5.6.6.4.2. The inhibition of the automatic closing process shall be indicated to the driver e.g. by a visual tell-tale.
- 5.6.6.4.3. The cancellation of the reversing of the automatic closing process shall be capable of being done only by the driver.
- 5.6.6.4.4. Paragraph 5.6.6.3. shall apply to the subsequent closing of the door.
- 5.6.7. Technical requirements for emergency doors
- 5.6.7.1. Emergency doors shall be capable of being easily opened from inside and from outside when the vehicle is stationary. However, this requirement shall not be construed as precluding the possibility of locking the door from the outside, provided that the door can always be opened from the inside by the use of the normal opening mechanism.
- 5.6.7.2. Emergency doors shall not be fitted with a power-operated system or be of the sliding type. If a sliding door has been shown to be capable of being opened without the use of tools after a frontal barrier collision test, in accordance with Regulation No. 33, it can be accepted as an emergency door.
- 5.6.7.3. The outside handles of emergency doors shall be not more than 180 cm from the ground when the vehicle is standing unladen on level ground.
- 5.6.7.4. Hinged emergency doors fitted to the side of the vehicle shall be hinged at their forward edge and shall open outwards. Check straps, chains or other restraining devices shall be permitted, provided that they do not prevent the door from opening to and remaining open at an angle of at least 100E. If a means is provided sufficient to give free passage to the emergency door access gauge, the 100E minimum angle requirement shall not apply.
- 5.6.7.5. If an emergency door is located adjacent to a toilet door or a door to another internal compartment the emergency door shall be protected against unintentional operation. However, this requirement shall not apply if the emergency door is locked automatically when the vehicle is moving at a speed exceeding 5 km/h.
- 5.6.7.6. All emergency doors which cannot easily be seen from the driver's seat shall be provided with an audible device to warn the driver when they are not securely

closed. The warning device shall be operated by the movement of the door catch and not by the movement of the door itself.

5.6.8. Technical requirements for emergency windows

5.6.8.1. Every hinged emergency window shall open outwards.

5.6.8.2. Every emergency window shall:

5.6.8.2.1. either be capable of being easily and instantaneously operated from inside and from outside the vehicle by means of a device recognized as satisfactory by the competent authority,

5.6.8.2.2. or be made of readily-breakable safety glass. This latter provision precludes the possibility of using panes of laminated glass or of plastic material.

5.6.8.3. Every emergency window which can be locked from the outside shall be so constructed as to be capable of being opened at all times from inside the vehicle.

5.6.8.4. If the emergency window is of a type horizontally hinged at the top edge, an appropriate device shall be provided to hold it open. Emergency windows which open or eject shall do so towards the exterior.

5.6.8.5. The height of the lower edge of an emergency window fitted in the side of the vehicle from the level of the floor immediately below it shall not be more than 100 cm nor less than 65 cm in the case of a hinged emergency window, or 50 cm in the case of a window made of breakable glass. However, in the case of a hinged emergency window the height of the lower edge may be reduced to a minimum of 50 cm provided that the window aperture is equipped with a guard up to a height of 65 cm to prevent the possibility of passengers falling out of the vehicle. Where the window aperture is equipped with a guard, the size of the window aperture above the guard shall not be less than the minimum size prescribed for an emergency window.

5.6.8.6. Every hinged emergency window which is not clearly visible from the driver's seat shall be fitted with an audible warning device to warn the driver when it is not completely closed. The window lock, and not the movement of the window itself, shall actuate this device.

5.6.9. Technical requirements for escape hatches

5.6.9.1. Every escape hatch shall operate so as not to obstruct clear passage from inside or outside the vehicle. The operation of ejectable escape hatches shall be such that inadvertent ejection is effectively prevented.

5.6.9.2. Escape hatches shall be capable of being easily opened or removed from the inside and from the outside. However, this requirement shall not be construed as precluding the possibility of locking the escape hatch for the purpose of securing the vehicle when unattended provided the escape hatch can always be opened from the inside by the use of the normal opening or removal mechanism.

5.6.10. Retractable steps

Retractable steps, if fitted, shall comply with the following requirements:

5.6.10.1. If power operated, their operation shall be synchronized with that of the corresponding service or emergency door;

5.6.10.2. When the door is closed no part of the retractable step shall project more than 10 mm beyond the adjacent line of the bodywork;

5.6.10.3. When the door is open and the retractable step is in the extended position, the surface area shall conform to the requirements of paragraph 5.7.7. of this Regulation.

5.6.10.4. In the case of the power operated step it shall not be possible for the vehicle to move from rest, under its own power, when the step is in the extended position. In the case of a manually operated step, an audible or visual indication shall alert the driver when the step is not fully retracted;

5.6.10.5. The step shall not be capable of being extended when the vehicle is in motion. If the device to operate the power operated step fails, the step shall retract and remain in the retracted position. However, the operation of the corresponding door shall not be hindered in the event of such a failure, or if the step is damaged;

5.6.10.6. When a passenger is standing on the power operated retractable step, the corresponding door shall be incapable of being closed. Compliance with this requirement shall be checked by placing a mass of 15 kg, representing a small child, as the centre of the step. This requirement shall not apply to any door within the driver's direct field of view;

5.6.10.7. The movement of the retractable step shall not be liable to cause any bodily harm either to passengers or to persons waiting at bus stops;

5.6.10.8. The corners of retractable steps facing forwards or rearwards shall be rounded to a radius of not less than 5 mm, the edges shall be rounded to a radius of not less than 2.5 mm;

5.6.10.9. When the passenger door is open, the retractable step shall be securely held in the extended position. When a mass of 136 kg is placed in the centre of a single step or a mass of 272 kg is placed in the centre of a double step, the deflection at any point on the step shall not exceed 10 mm.

5.6.11. Markings

5.6.11.1. Each emergency exit shall be marked by an inscription reading "Emergency exit" inside and outside the vehicle.

5.6.11.2. The emergency controls of service doors and of all emergency exits shall be marked as such inside and outside the vehicle either by a representative symbol or by a clearly-worded inscription.

5.6.11.3. Clear instructions concerning the method of operation shall be placed on or close to every emergency control of an exit.

5.6.11.4. The language in which the markings referred to in paragraphs 5.6.11.1. to 5.6.11.3. above are to be inscribed shall be determined by the competent administrative department of the country of registration of the vehicle.

5.7. Interior arrangements

5.7.1. Access to service door (see annex 3, figure 1)

5.7.1.1. The free space extending inwards into the vehicle from the sidewall in which the door is mounted shall permit the free passage of a vertical rectangular panel 2 cm thick, 40 cm wide, and 70 cm in height above the floor, having a second panel superimposed above it with the following dimensions:

Vehicles of class A: 55 cm wide and 95 cm high;

Vehicles of class B: 55 cm wide and 70 cm high.

The width of the upper panel may be reduced at the top to 40 cm when a chamfer not exceeding 30 degrees from the horizontal is included (annex 3, figure 1).

The lower panel shall be within the projection of the upper panel. A relative displacement between the two panels shall be allowed provided that it is always in the same direction.

The dual panel shall be maintained parallel with the door aperture as it is moved from the starting position, where the plane of the face nearest to the interior of the vehicle is tangential to the outermost edge of the aperture, to the position where it touches the first step, after which it shall be kept at right angles to the probable direction of motion of a person using the entrance.

- 5.7.1.2. As an alternative, a trapezoidal section, having a height of 50 cm, forming the transition between the width of the upper and the lower panel, may be used. In this case, the total height of the rectangular section and this trapezoidal section of the upper panel shall be 95 cm.
- 5.7.1.3. When the centreline of this dual panel has traversed a distance of 30 cm from its starting position and the dual panel is touching the step surface, it shall be retained in that position.
- 5.7.1.4. The cylindrical figure (annex 3, figure 3) used for testing the gangway clearance shall then be moved starting from the gangway, in the probable direction of motion of a person leaving the vehicle, until its centreline has reached the vertical plane which contains the top edge of the uppermost step, or until a plane tangential to the upper cylinder touches the dual panel, whichever occurs first, and retained in that position (see annex 3, fig. 17).
- 5.7.1.5. Between the cylindrical figure, at the position set out in paragraph 5.7.1.4. and the dual panel, at the position set out in paragraph 5.7.1.3., there shall be a free space whose upper and lower limits are shown in annex 3, figure 17. This free space shall permit the free passage of a vertical panel whose form and dimensions are the same as the cylindrical form (paragraph 5.7.5.1.) central section and a thickness of no more than 2 cm. This panel shall be moved, from the cylindrical form tangential position, until its external side is in contact with the dual panel interior side, touching the plane or planes defined by the step upper edges, in the probable direction of motion of a person using the entrance (see annex 3, figure 17).
- 5.7.1.6. The free passage clearance for this figure shall not include any space extending to 30 cm in front of any undepressed seat cushion and to the height of the top of the seat cushion.
- 5.7.1.7. In the case of folding seats, this space shall be required to be determined with the seat in the position of use.

- 5.7.1.8. However, a folding seat for use by the crew may obstruct the access passage to a service door when in the position of use provided that:
- 5.7.1.8.1. it is clearly indicated, both in the vehicle itself and on the communication form (annex 1), that the seat is for the use of crew only;
- 5.7.1.8.2. when the seat is not in use it folds automatically as necessary to comply with the requirements of paragraphs 5.7.1.1. or 5.7.1.2. and 5.7.1.3. to 5.7.1.5.;
- 5.7.1.8.3. the door is not considered to be a mandatory exit for the purpose of paragraph 5.6.1.3.;
- 5.7.1.8.4. the seat is fitted with a retractable safety-belt; and
- 5.7.1.8.5. when the seat is in the position of use, and when it is in the folded position, no part of it shall be forward of a vertical plane passing through the centre of the seating surface of the driver's seat in its rearmost position and through the centre of the exterior rear-view mirror mounted on the opposite side of the vehicle.
- 5.7.1.9. The service door and emergency door dimensions in paragraph 5.6.3.1. and the requirements of paragraphs 5.7.1.1. to 5.7.1.7., 5.7.2.1. to 5.7.2.3., 5.7.5.1. and 5.7.8.5. shall not apply to a vehicle of class B with a mass not exceeding 3.5 tonnes and up to 12 passenger seats in which each seat has unobstructed access to at least two doors.
- 5.7.1.10. A doorway and the route by which passengers gain access to it shall be considered unobstructed if they have:
- 5.7.1.10.1. measured parallel with the longitudinal axis of the vehicle, there is a clearance of not less than 22 cm at any point and 55 cm at any point being more than 50 cm above the floor or steps (annex 3, figure 19);
- 5.7.1.10.2. measured perpendicular to the longitudinal axis of the vehicle, there is a clearance of not less than 30 cm at any point and 55 cm at any point being more than 120 cm above the floor or steps or less than 30 cm below the ceiling (annex 3, figure 20).
- 5.7.1.11. Gangways and access passages shall be covered with an anti-slip material.
- 5.7.1.12. The maximum slope of the floor in the access passage shall not exceed 5 per cent.

5.7.2. Access to emergency doors (see annex 3, figure 2)

5.7.2.1. The free space between the gangway and the emergency door aperture shall permit the free passage of a vertical cylinder 30 cm in diameter and 70 cm high from the floor and supporting a second vertical cylinder 55 cm in diameter, the aggregate height of the assembly being 140 cm.

5.7.2.2. The base of the first cylinder shall be within the projection of the second cylinder.

5.7.2.3. Where folding seats are installed alongside this passage, the free space for the cylinder shall be required to be determined with the seat in the opened position.

5.7.2.4. For the driver's door to be accepted as an emergency door for the main passengers' compartment, it shall:

5.7.2.4.1. either satisfy all the requirements as to dimensions of the door aperture and accessibility, or

5.7.2.4.2. satisfy the requirements relating to the dimensions of emergency doors indicated in paragraph 5.6.3.1., fulfil the requirements indicated in paragraph 5.6.2.5.2., and exclude any possibility of encountering an obstacle between the driver's seat and the driver's service door.

5.7.2.5. If there is a door opposite the driver's door, the provisions of paragraph 5.7.2.4. shall apply to it, provided that there is not more than one passenger's seat beside the driver.

5.7.2.6. In the case of a vehicle to which paragraph 5.7.1.9. applies, access to the doors shall be provided in accordance with that paragraph.

5.7.3. Access to emergency windows

5.7.3.1. It shall be possible to move a test gauge from the gangway to the exterior of the vehicle through every emergency window.

5.7.3.2. The direction of motion of the test gauge shall be in the direction in which a passenger evacuating the vehicle would be expected to move. The test gauge shall be kept perpendicular to that direction of motion.

5.7.3.3. The test gauge shall be in the form of a thin plate having a size of 60 x 40 cm with corners radiused by 20 cm. However, in the case of an emergency window

in the rear face of the vehicle, the test gauge may alternatively have a size of 140 cm x 35 cm with corners radiused by 17.5 cm.

5.7.4. Access to escape hatches

Escape hatches shall be situated above at least part of a seat or some other equivalent support affording access to them.

- 5.7.4.1. If an escape hatch is fitted in a Class B vehicle, at least one escape hatch shall be located such that a four-sided truncated pyramid having a side angle of 20° and a height of 1,600 mm touches part of a seat or equivalent support. The axis of the pyramid shall be vertical and its smaller section shall contact the aperture area of the escape hatch. Supports may be foldable or movable provided they can be locked in their position of use. This position shall be taken for verification.

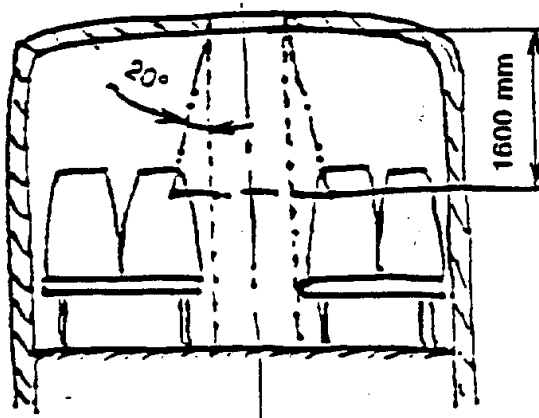

- 5.7.4.2. When the structural thickness of the roof is more than 150 mm, the smaller section of the pyramid shall contact the aperture area of the escape hatch at the level of the outside surface of the roof.

5.7.5. Gangways (see annex 3, figure 3)

- 5.7.5.1. The gangway of a vehicle shall be so designed and constructed as to permit the free passage of a gauging device consisting of two coaxial cylinders with an inverted truncated cone interposed between them, the gauging device having the following dimensions (in cm):

		Class A	Class B
Lower Cylinder	Diameter	35	30
	Height	90	90
Upper Cylinder	Diameter	55 <u>*/</u>	45 <u>*/</u>
	Height	50 (40) <u>±/</u>	30
Overall Height		190 (180) <u>±/</u>	150

*/ The diameter of the upper cylinder may be reduced to 30 cm at the top when a chamfer not exceeding 30E from the horizontal is included (see annex 3, figure 3).

±/ The height of the upper cylinder may be reduced by 10 cm in any part of the gangway which is located to the rear of the most forward of the following two planes:
a transverse vertical plane situated 1.5 m forward of the centreline of the rear axle (foremost rear axle in the case of vehicles with more than one rear axle), and
a transverse vertical plane situated at the rear edge of the rearmost service door.

The gauging device may come into contact with strap hangers, if fitted, and move them away.

- 5.7.5.1.1. On vehicles of Class A, the diameter of the lower cylinder may be reduced from 35 cm to 30 cm in any part of the gangway which is located to the rear of the most forward of the following two planes:
- 5.7.5.1.1.1. a transverse vertical plane situated 1.5 m forward of the centreline of the rear axle (foremost rear axle in the case of vehicles with more than one rear axle);
- 5.7.5.1.1.2. a transverse vertical plane situated at the rear edge of the rearmost service door in between the axles.
- 5.7.5.2. Steps may be fitted in the gangways. The width of such steps shall not be less than the width of the gangway at the top of the steps.
- 5.7.5.3. Folding seats allowing passengers to sit in the gangway shall not be permitted.

5.7.5.4. In the case of vehicles to which paragraph 5.7.1.9. applies, a gangway shall not be necessary provided the access dimensions specified in that paragraph are respected.

5.7.6. Slope of the gangway

The slope of the gangway shall not exceed:

5.7.6.1. In the longitudinal direction:

5.7.6.1.1. 8 per cent in the case of a vehicle of Class A, or

5.7.6.1.2. 12.5 per cent in the case of a vehicle of Class B.

5.7.6.2. In the transversal direction 5 per cent for all classes.

5.7.7. Steps (See annex 3, figure 4)

5.7.7.1. the maximum and minimum height, and the minimum depth, of steps for passengers at service and emergency doors and within the vehicle are specified in annex 3, figure 4.

5.7.7.1. The maximum and minimum height, and the minimum depth, of steps for passengers at service and emergency doors and within the vehicle are specified in annex 3, figure 4.

5.7.7.2. For the purpose of this paragraph the height of a step shall be measured at the centre of its width. Furthermore, manufactures should specifically take account of access by handicapped particularly in relation to a step height to be kept to a minimum.

5.7.7.3. Any transition from a sunken gangway to a seating area shall not be considered to be an step. However, the vertical distance between the gangway surface and the floor of the seating area shall not exceed 35 cm.

5.7.7.4. The height of the first step in relation to the ground shall be measured with the vehicle being at its unladen kerb mass, the tyre equipment and pressure being as specified by the manufacturers for the maximum technical mass declared in accordance with paragraph 3.2.3.

5.7.7.5. Where there is more than one step, each step may extend into the area of the vertical projection of the next step 10 cm and the projection over the tread below shall leave a free surface of at least 20 cm (see annex 3, figure 4).

- 5.7.7.6. The area of any step shall be not less than 800 cm².
- 5.7.7.7. The maximum slope of the step in any direction shall not exceed 5 per cent.
- 5.7.8. Passenger seats (including folding seats) and space for seated passengers
- 5.7.8.1. Each seating place shall have a vertical clearance of not less than 90 cm from the highest point of the undepressed seat cushion and at least 135 cm from the floor where the feet of the seated passenger rest. In the case of vehicles to which paragraph 5.7.1.9. applies, this dimension may be reduced to 120 cm.
- 5.7.8.1.1. This clear space shall extend over the whole horizontal area defined below:
- 5.7.8.1.1.1. the rectangular area of 40 cm in width, symmetrical in relation to the median vertical plane of the seat, and having a length "L" defined in figure 5, annex 3, which represents a section through the median vertical plane of the seat;
- 5.7.8.1.1.2. the area intended for the feet of the seated passenger, over the same width of 40 cm and a depth of 30 cm.
- 5.7.8.1.2. However, this space shall not include, in its upper part adjacent to the wall of the vehicle, a rectangular area 15 cm in height and 10 cm in width (see annex 3, figure 6).
- 5.7.8.1.3. In the space extending above the area mentioned in paragraph 5.7.8.1.1.2. the following intrusions shall be permitted:
- 5.7.8.1.3.1. intrusion of the back of another seat;
- 5.7.8.1.3.2. intrusion of a structural member provided that intrusion is included within a triangle whose peak is situated 65 cm from the floor and whose base is 10 cm in width and is situated in the upper part of the space in question, adjacent to the side wall of the vehicle (annex 3, fig. 7);
- 5.7.8.1.3.3. Intrusion situated in the lower part of the space in question, adjacent to the sidewall of the vehicle, of a cross-sectional area not exceeding 200 cm² and having a maximum width of 10 cm (annex 3, figure 8).
- 5.7.8.1.3.4. Intrusion of a wheel arch provided that one of the following two conditions is fulfilled:
- 5.7.8.1.3.4.1. the intrusion does not extend beyond the vertical centreline of the seat (annex 3, figure 9), or

- 5.7.8.1.3.4.2. the area 30 cm in depth available for the feet of the seated passenger is advanced by not more than 20 cm from the edge of the seat cushion and not more than 60 cm in front of the squab of the seat (annex 3, figure 10), these measurements being made in the median vertical plane of the seat.
- 5.7.8.1.3.5. In the case of the seats of the first row, intrusion of the instrument panel in the limit of 10 cm and only at heights from the floor greater than 65 cm.
- 5.7.8.1.3.6. Intrusion of hopper type windows when open and their fittings.
- 5.7.8.1.4. In the case of the two rear side seating places, the rear edge adjacent to the side wall of the vehicle of the space situated above the area mentioned in paragraph 5.7.8.1.1.1. may be replaced by a cylindrical segment 15 cm in radius (annex 3, figure 11).
- 5.7.8.1.5. In the case of the seats of the first row, the front upper edge of the space extending over the area defined in paragraph 5.7.8.1.1.2. may be replaced by a plane parallel to this edge, making an angle of 45° with the horizontal and passing through the rear upper edge of this space.
- 5.7.8.2. Seat dimensions (see annex 3, figures. 12 and 13)
- 5.7.8.2.1. The minimum dimensions for each seating place, as measured from a vertical plane passing through the centre of that seating place, shall be as follows:

Individual seats	Width of the seat cushion on each side	20 cm
	Width of the available space, measured in a horizontal plane along the seat back at heights between 27 and 65 cm above the undepressed seat cushion	25 cm
Continuous seats for two or more passengers	Width of the seat cushion per passenger, on each side	20 cm
	Width of the available space, measured in a horizontal plane along the seat-back at heights between 27 and 65 cm above the undepressed seat cushion	22.5 cm

- 5.7.8.2.2. In the case of seats adjacent to the wall of the vehicle, the available space does not include, in its upper part, a triangular area 2 cm wide by 10 cm high (see annex 3, figure 13).

5.7.8.3. Seat cushions (see annex 3, figure. 14)

5.7.8.3.1. The height of the undepressed seat cushion relative to the floor under the passenger's feet shall be such that the distance from the floor to a horizontal plane tangent to the front upper surface of the seat cushion is between 40 and 50 cm; this height may, however, be reduced to not less than 35 cm at the wheel arches.

5.7.8.3.2. The depth of the seat cushion shall be at least 35 cm.

5.7.8.4. Seat spacing (see annex 3, figure 15)

5.7.8.4.1. In the case of seats facing in the same direction, the distance between the front of a seat squab and the back of the squab of the seat preceding it shall, when measured horizontally and at all heights above the floor between the level of the top surface of the seat cushion and a point 62 cm above the floor, be not less than 65 cm.

5.7.8.4.2. All measurements shall be taken, with the seat cushion and squab undepressed in a vertical plane passing through the centreline of the individual seating place.

5.7.8.4.3. Where transverse seats face one another the minimum distance between the front faces of the seat squabs of facing seats, as measured across the highest points of the seat cushions, shall be not less than 130 cm.

5.7.8.5. Space for seated passengers (see annex 3, figure 16)

5.7.8.5.1. A minimum clear space in front of each passenger seat shall be provided as shown in annex 3, figure 16. The seat back of another preceding seat or a partition whose contour corresponds approximately to that of the inclined seat back may intrude into this space as provided by paragraph 5.7.8.4.; the local presence in this space of seat legs shall also be permitted provided that adequate space remains for the passenger's feet.

5.7.8.5.2. However, at least two forward or rearward facing seats specifically intended and marked for disabled passengers shall be provided in that part of the vehicle which is most suitable for boarding. These seats shall be designed for the disabled so as to provide enough space, shall have suitably designed and placed handholds to facilitate entry and exit of the seat and provide communication from the seated position with the driver if necessary.

5.8. Artificial interior lighting

5.8.1. Internal electrical lighting shall be provided for the illumination of:

5.8.1.1. the passenger compartment;

5.8.1.2. any step or steps;

5.8.1.3. the access to any exits;

5.8.1.4. the internal markings and internal controls of all exits;

5.8.1.5. all places where there are obstacles.

5.9. Handrails and handholds

5.9.1. General requirements

5.9.1.1. Handrails and handholds shall be of adequate strength.

5.9.1.2. They shall be so designed and installed as to present no risk of injury to passengers.

5.9.1.3. Handrails and handholds shall be of a section enabling passengers to grasp them easily and firmly. Every handrail shall provide a length of at least 10 cm to accommodate a hand. No dimension of the section shall be smaller than 2 cm or greater than 4.5 cm except in the case of handrails on doors and seats and in the case of a vehicle of class B, in access passages. In these cases handrails having a minimum dimension of 1.5 cm shall be permitted provided that one other dimension is of at least 2.5 cm.

5.9.1.4. The clearance between a handhold and the adjacent part of the vehicle body or walls shall be of at least 4 cm. However, in the case of a handrail on a door or a seat, or in the access passage of a vehicle of class B a minimum clearance of 3.5 cm shall be permitted.

5.9.1.5. The surface of every handrail, handhold or stanchion shall be colour contrasting and non-slip.

5.9.2. Handrails and handholds for class A vehicles

5.9.2.1. Handrails and/or handholds shall be provided in sufficient number for each point of the floor area intended, in conformity with paragraph 5.2.2., for standing passengers. This requirement shall be deemed to be fulfilled if, for all possible sites of the testing device shown in annex 3, figure 18 of this Regulation at least two handrails and/or handholds can be reached by the device's movable arm. For this purpose, strap hangers, if fitted, may be counted as handholds provided that they are held in their position by suitable means. The testing device may be freely turned about its vertical axis.

5.9.2.2. When applying the procedure described in paragraph 5.9.2.1. above, only such handrails and/or handholds shall be considered as are not less than 80 cm and not more than 190 cm above the floor.

5.9.2.3. For every position that can be occupied by a standing passenger, at least one of the two required handrails and/or handholds shall not be more than 150 cm above the level of the floor at that position. Exception may be given in the middle of large platforms, but the sum of these exceptions shall not exceed 20 per cent of the total standing area.

5.9.2.4. Areas which can be occupied by standing passengers and are not separated by seats from the side walls or rear wall of the vehicle shall be provided with horizontal handrails parallel to the walls and installed at a height of between 80 cm and 150 cm above the floor.

5.9.3. Handrails and handholds for service doors

5.9.3.1. Door apertures shall be fitted with handholds on each side of the passage for access by passengers. For double doors, this requirement may be met by one central stanchion or handhold.

5.9.3.2. Handrails and/or handholds to be provided for service doors shall be such that they include a grasping point available to a person standing on the ground adjacent to the service door or on any of the successive steps. Such points shall be situated, vertically, between 80 and 110 cm above the ground or above the surfaces of each step, and horizontally,

5.9.3.2.1. for the position appropriate to a person standing on the ground, not more than 40 cm inwards from the outer edge of the first step; and

5.9.3.2.2. for the position appropriate to a particular step, not outwards from the outer edge of the step considered, and not more than 60 cm inwards from the inboard edge of that step.

5.9.4. Handrails and handholds for the handicapped

5.9.4.1. Handrails and handholds between the service door and the seats identified in accordance with paragraph 5.7.8.5.2. shall be designed to specifically take into account the needs of the handicapped.

5.10. Guarding of stepwells

5.10.1. Where any seated passenger is likely to be thrown forward into a step well as a result of heavy braking, either a guard or a safety-belt shall be fitted. Where a guard is provided, it shall have a minimum height from the floor on which the passenger's feet rest of 80 cm and shall extend inwards from the wall of the vehicle at least as far as 10 cm beyond the longitudinal centre line of any seating position where the passenger is at risk or to the riser of the innermost step; whichever is the lesser dimension.

5.11. Luggage racks, if fitted, driver protection

5.11.1. The driver shall be protected from objects liable to fall from luggage racks in the case of heavy braking.

5.12. Trap doors, if fitted

5.12.1. Every trap door in the floor of a vehicle shall be so fitted and secured that it cannot be dislodged or opened without the use of tools or keys and no lifting or securing device shall project by more than 8 mm above floor level. Edges of projections shall be rounded.

5.13. Reversing lights

5.13.1. All vehicles having a service door in their rear face shall be equipped with reversing lights, the installation of which must conform to the provisions of Regulation No. 48.

6. MODIFICATION AND EXTENSION OF APPROVAL OF A TYPE OF VEHICLE

6.1. Every modification of the vehicle type shall be notified to the administrative department which approved the vehicle type. That department may then either:

- 6.1.1. consider that the modifications made are unlikely to have an appreciable adverse effect and that, in any case, the vehicle still meets the requirements; or
- 6.1.2. require a further test report from the technical service responsible for conducting the tests.
- 6.2. Confirmation or refusal of approval, specifying the modifications, shall be communicated by the procedure specified in paragraph 4.3. above to the Contracting Parties to the Agreement which apply this Regulation.
- 6.3. The competent authority issuing the extension of approval shall assign a series number for such an extension and inform thereof the other Parties to the 1958 Agreement applying this Regulation by means of a communication form conforming to the model in annex 1 to this Regulation.
7. CONFORMITY OF PRODUCTION
- 7.1. Every vehicle bearing an approval mark as prescribed under this Regulation shall conform to the vehicle type approved.
- 7.2. In order to verify conformity as prescribed in paragraph 7.1. above, a sufficient number of random checks shall be made on serially-manufactured vehicles bearing the approval mark required by this Regulation.
8. PENALTIES FOR NON-CONFORMITY OF PRODUCTION
- 8.1. The approval granted in respect of a vehicle type pursuant to this Regulation may be withdrawn if the requirement laid down in paragraph 7.1. above is not complied with or if the vehicle fails to pass the test provided for in paragraph 7 above.
- 8.2. If a Contracting Party to the Agreement applying this Regulation withdraws an approval it has previously granted, it shall forthwith notify the other Contracting Parties applying this Regulation, by means of a communication form conforming to the model in annex 1 to this Regulation.
9. PRODUCTION DEFINITELY DISCONTINUED
- If the holder of the approval completely ceases to manufacture a vehicle type approved in accordance with this Regulation, he shall so inform the authority which granted the approval. Upon receiving the relevant communication, that authority shall inform thereof the other Parties to the 1958 Agreement applying

this Regulation by means of a communication form conforming to the model in annex 1 to this Regulation.

10. TRANSITIONAL PROVISIONS

10.1. As from the official date of entry into force of the 01 series of amendments to this Regulation, no Contracting Party applying this Regulation shall refuse approval under this Regulation as amended by the 01 series of amendments.

10.2. As from 3 years after the official date of entry into force mentioned in paragraph 10.1. above, Contracting Parties applying this Regulation shall grant approvals only if the type of vehicle corresponds to the requirements of this Regulation as amended by the 01 series of amendments.

10.3. As from 6 years after the official date of entry into force mentioned in paragraph 10.1. above, Contracting Parties applying this Regulation may refuse to recognize approvals which were not granted in accordance with the 01 series of amendments to this Regulation.

11. NAMES AND ADDRESSES OF TECHNICAL SERVICES RESPONSIBLE FOR CONDUCTING APPROVAL TESTS, AND OF ADMINISTRATIVE DEPARTMENTS

The Parties to the Agreement applying this Regulation shall communicate to the United Nations Secretariat the names and addresses of the technical services responsible for conducting approval tests and of the administrative departments which grant approval and to which forms certifying approval or extension or refusal or withdrawal of approval, issued in other countries, are to be sent.

Annex 1
(Maximum format: A4 (210 x 297 mm))

COMMUNICATION



issued by: Name of administration:

.....
.....
.....

concerning: 2/ APPROVAL GRANTED
APPROVAL EXTENDED
APPROVAL REFUSED
APPROVAL WITHDRAWN
PRODUCTION DEFINITELY DISCONTINUED

of a vehicle type class A/class B 2/ with regard to its general construction, pursuant to Regulation No. 52.

Approval No.:

Extension No.:

1. Trade name or mark of the power-driven vehicle
2. Vehicle type
3. Name and address of applicant for approval
4. If applicable, name and address of representative of applicant for approval
5. Brief description of the vehicle type as regards its structure, dimensions, configuration and constituent material
6. Technical maximum mass of vehicle when tested (kg):
 - 6.1. front axle load (kg)
 - 6.2. rear axle load (kg)
 - 6.3. total (MT) (kg)
7. Unladen mass (MV) (kg)
8. Carriage of baggage or goods
 - 8.1. total volume of baggage compartments or goods compartments (V)(m³)
 - 8.2. total mass of baggage or goods these compartments can contain (B) (kg)
 - 8.3. carriage of baggage or goods on the roof provided for: yes/no 2/

- 8.3.1. total area of roof equipped for carriage of baggage or goods (VX)(m²)
- 8.3.2. total mass of baggage or goods which may be carried in this area (BX)
(kg)
- 9. Area for passengers:
 - 9.1. total (S₀) (m²)
 - 9.2. for standing passengers (S₁) (m²)
- 10. Calculated values:
 - 10.1. Number of seating and standing places according to paragraph 5.3.2. of this Regulation:
 - 10.1.1. Total (N = P_s + P_{st}):
 - 10.1.2. Seating places (P_s):
 - 10.1.3. Standing places (P_{st}):
- 11. Masses according to paragraph 5.3.3. of this Regulation:
 - 11.1. Total vehicle mass: (kg)
 - 11.2. First axle mass: (kg)
 - 11.3. Second axle mass: (kg)
 - 11.4. Third axle mass (if any): (kg)
- 12. Vehicle submitted for approval on
- 13. Technical service responsible for conducting approval tests
- 14. Date of report issued by that service
- 15. Number of report issued by that service
- 16. Approval is granted/extended/refused/withdrawn 1/
- 17. Position of approval mark on the vehicle
- 18. Place
- 19. Date
- 20. Signature
- 21. The list of documents filed with the administration service which has granted approval and available on request is annexed to this communication.

1/ Distinguishing number of the country which has granted/extended/refused/withdrawn approval (see approval provisions in the Regulations).
2/ Strike out what does not apply.

Annex 2

ARRANGEMENTS OF APPROVAL MARK

Model A

(See paragraph 4.4. of this Regulation)

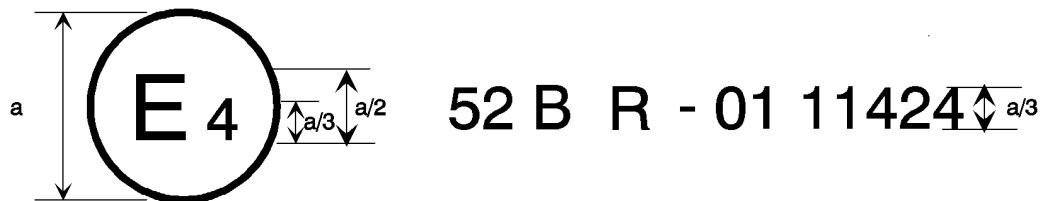

a = 8 mm min.

The above approval mark affixed to a vehicle shows that the vehicle type concerned has, with regard to its general construction, been approved in the Netherlands (E 4) for class B pursuant to Regulation No. 52 under approval No. 011424. The first two digits of the approval number indicate that the approval was granted in accordance with the requirements of Regulation No. 52 as amended by the 01 series of amendments.

Model B

(See paragraph 4.5. of this Regulation)

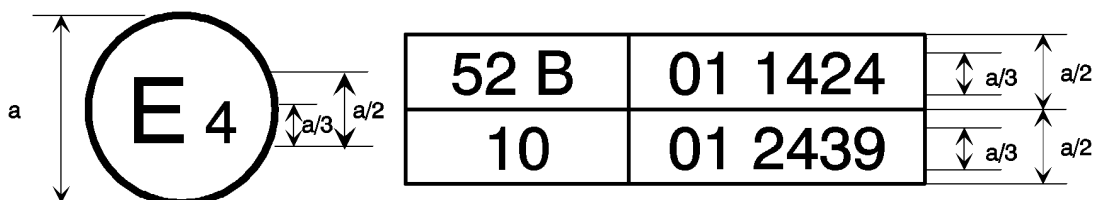

a = 8 mm min.

The above approval mark affixed to a vehicle shows that the vehicle type concerned has been approved in the Netherlands (E 4) for class B pursuant to Regulations Nos. 52 and 10. 1/ The approval numbers indicate that, at the dates when the respective approvals were given, Regulation No. 52 included the 01 series of amendments, as well as Regulation No. 10.

1/ This number is given merely as an example.

Annex 3

EXPLANATORY DIAGRAMS

Figure 1
Access to service doors
(See paragraph 5.7.1.)

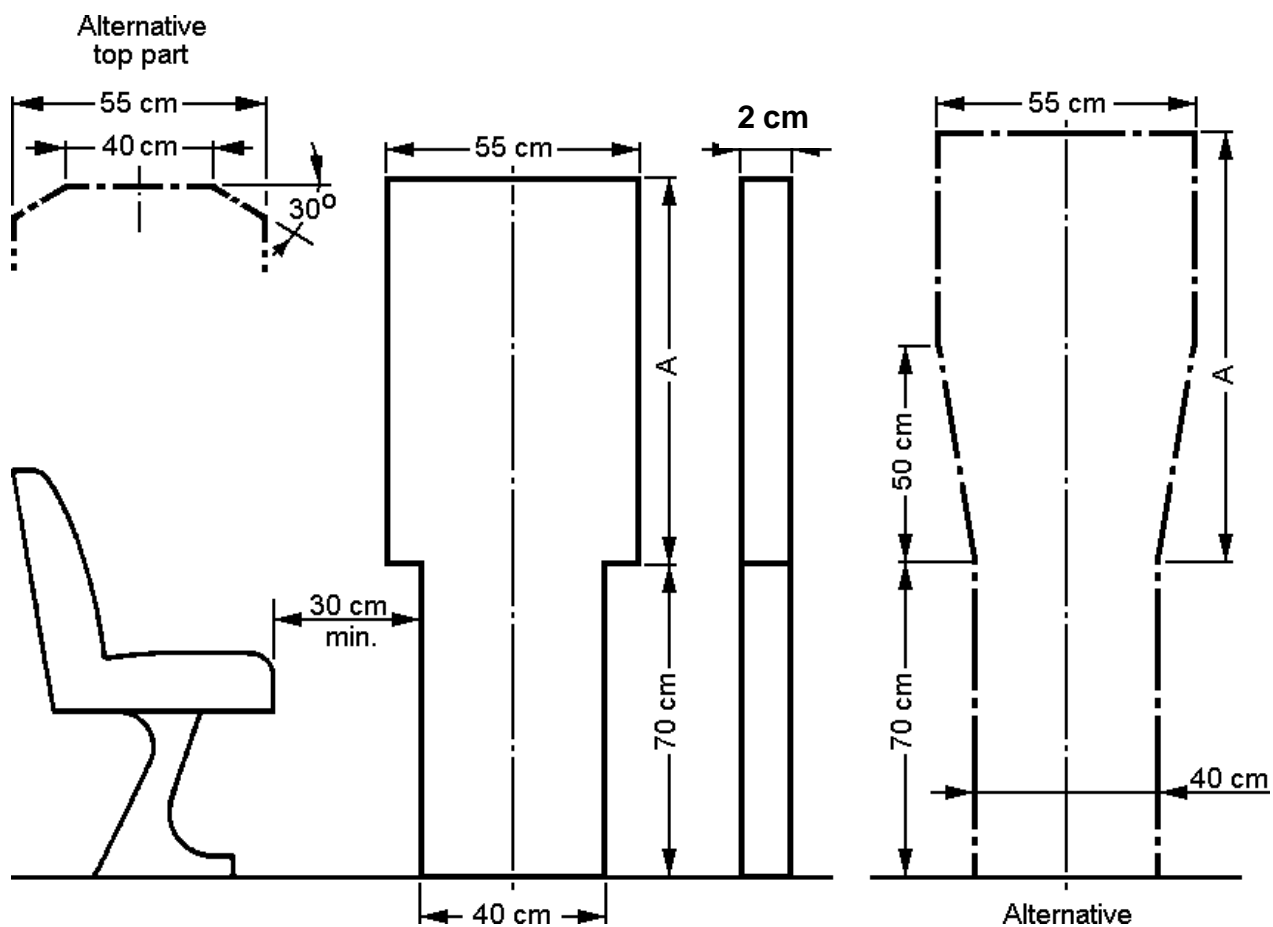

Figure 2

Access to emergency doors
(See paragraph 5.7.2.)

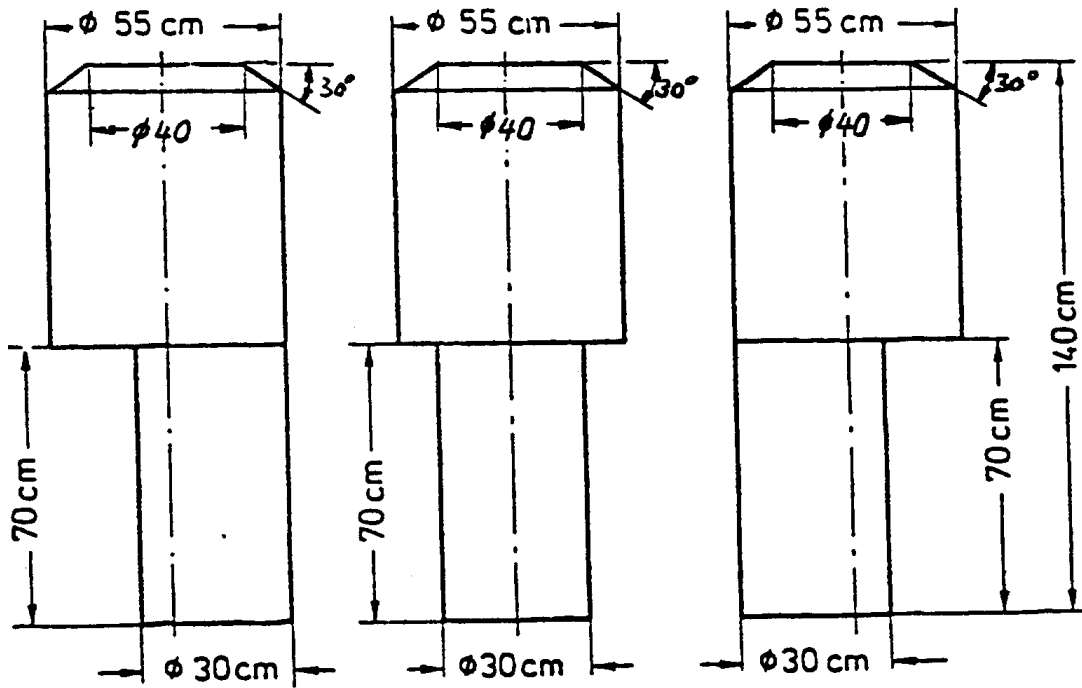
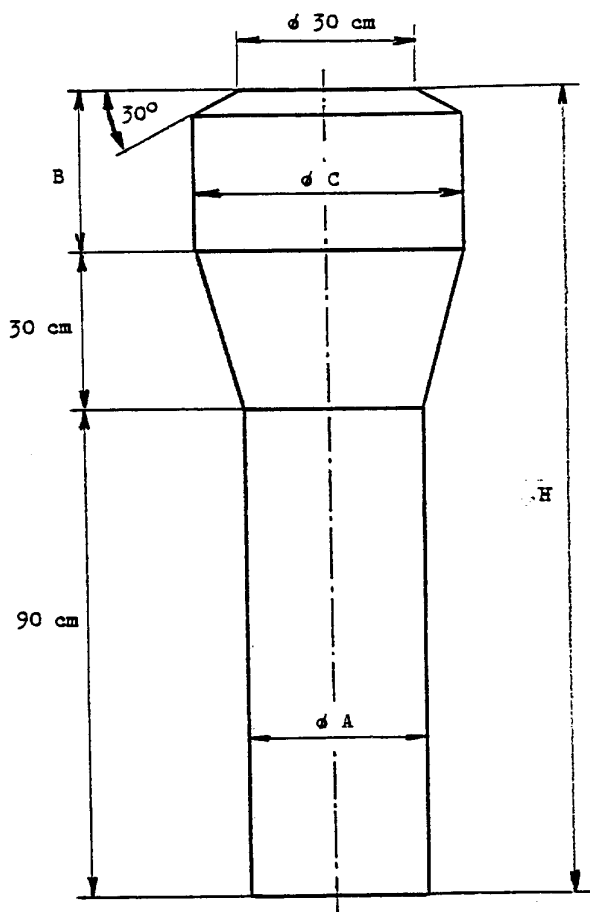

Figure 3

Gangways
 (see paragraph 5.7.5.)



Dimensions in cm

Dimensions (cm)	Ø A	B	Ø C	H
Class A	35	50 (40) ±/	55	190 (180) ±/
Class B	30	30	45	150

*/ See the respective footnote ("±/") of paragraph 5.7.5.1.

Figure 4

Steps at service doors
 (See paragraph 5.7.7.)

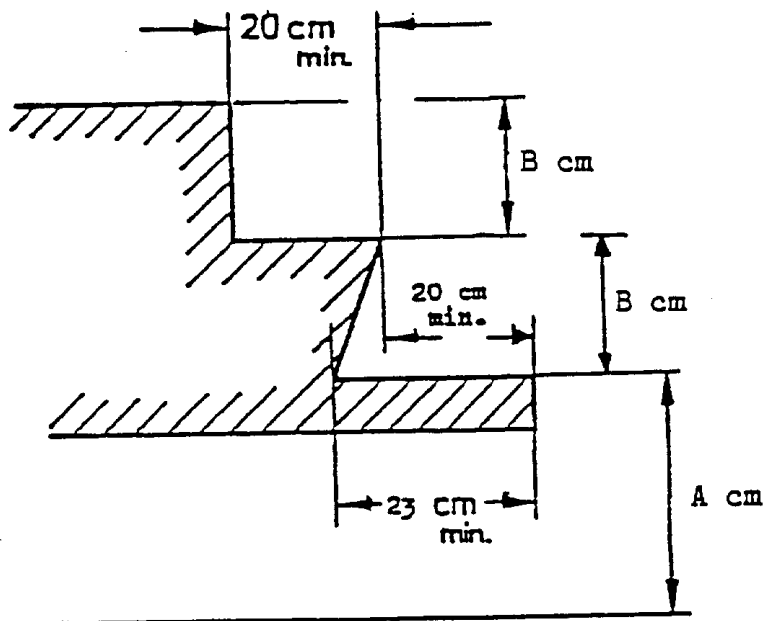

	A (cm) <u>1/ 3/</u>	B (cm) <u>1/ 2/</u>	
	max.	min.	max.
Class A	36	12	25 <u>4/</u>
Class B	40	12	35
mechanical suspension solely	43		

Notes:

- 1/ At a double doorway the steps in each half of the access passage shall be treated separately.
- 2/ B need not be the same for each step.
- 3/ 70 cm in the case of an emergency door.
- 4/ 30 cm in the case of steps at a door behind the rearmost axle.”

Figure 5

Length of prescribed seat area
(See paragraph 5.7.8.1.1.1.)

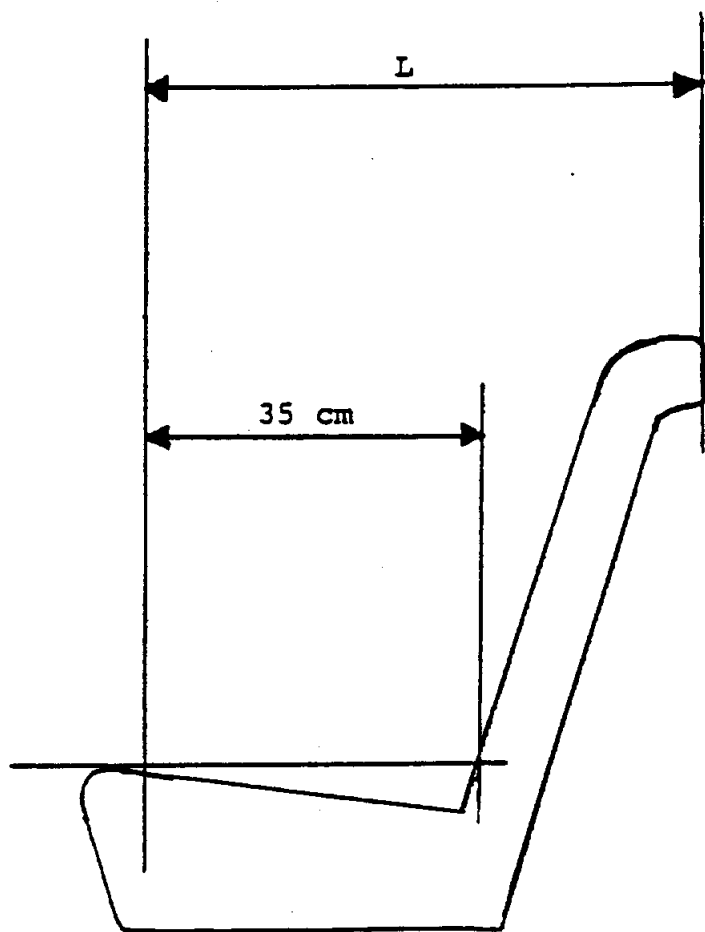

Figure 6

Permitted intrusion into space above seat

Transversal section of the minimum free space above a seating place adjacent to the wall of the vehicle

(See paragraph 5.7.8.1.2.)

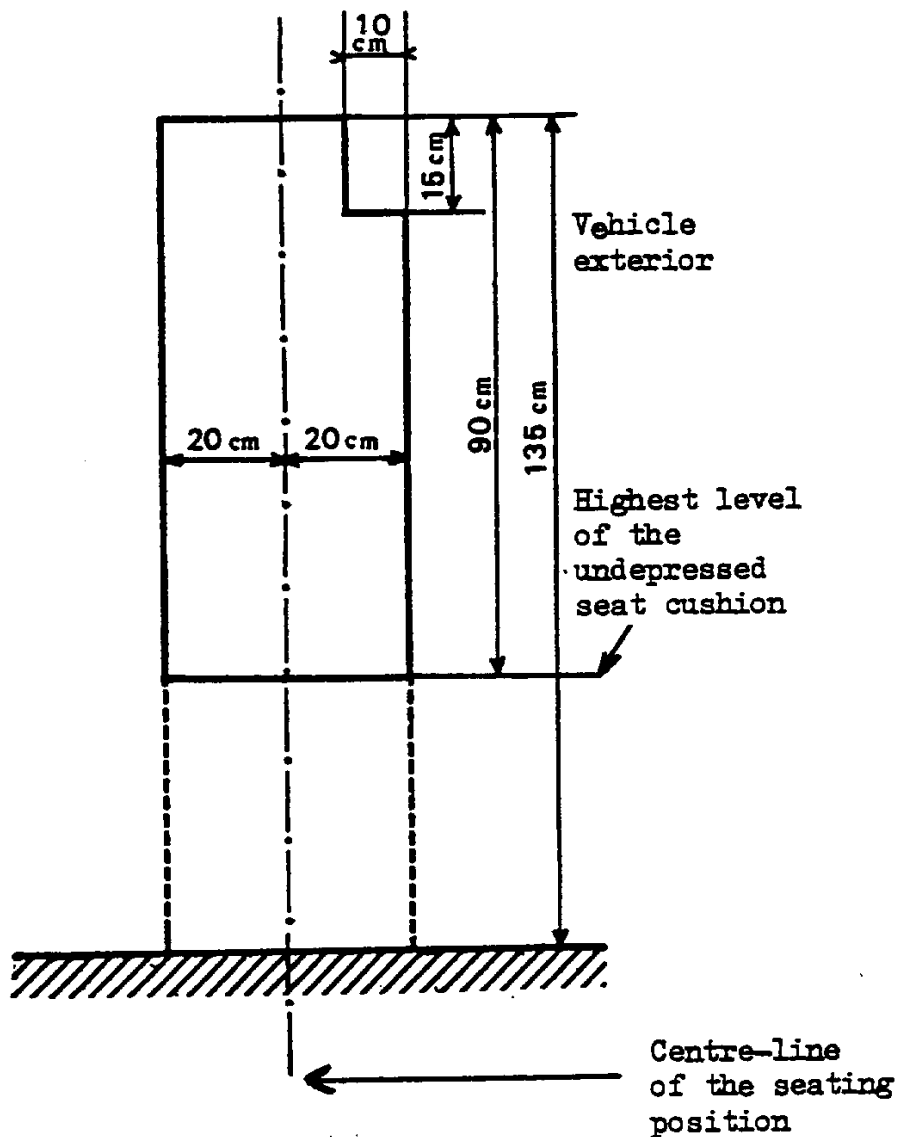

Figure 7

Permitted intrusion of a structural member

Definition of the triangle allowing for the intrusion of a structural member
(See paragraph 5.6.8.1.3.2)

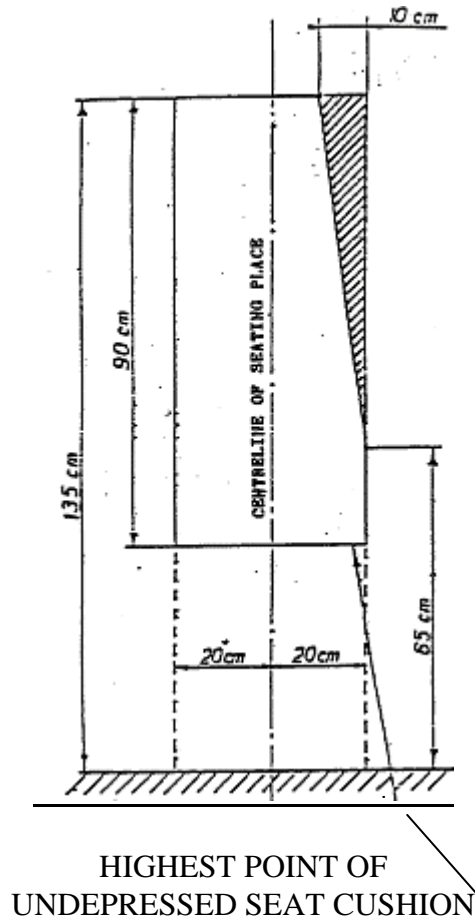
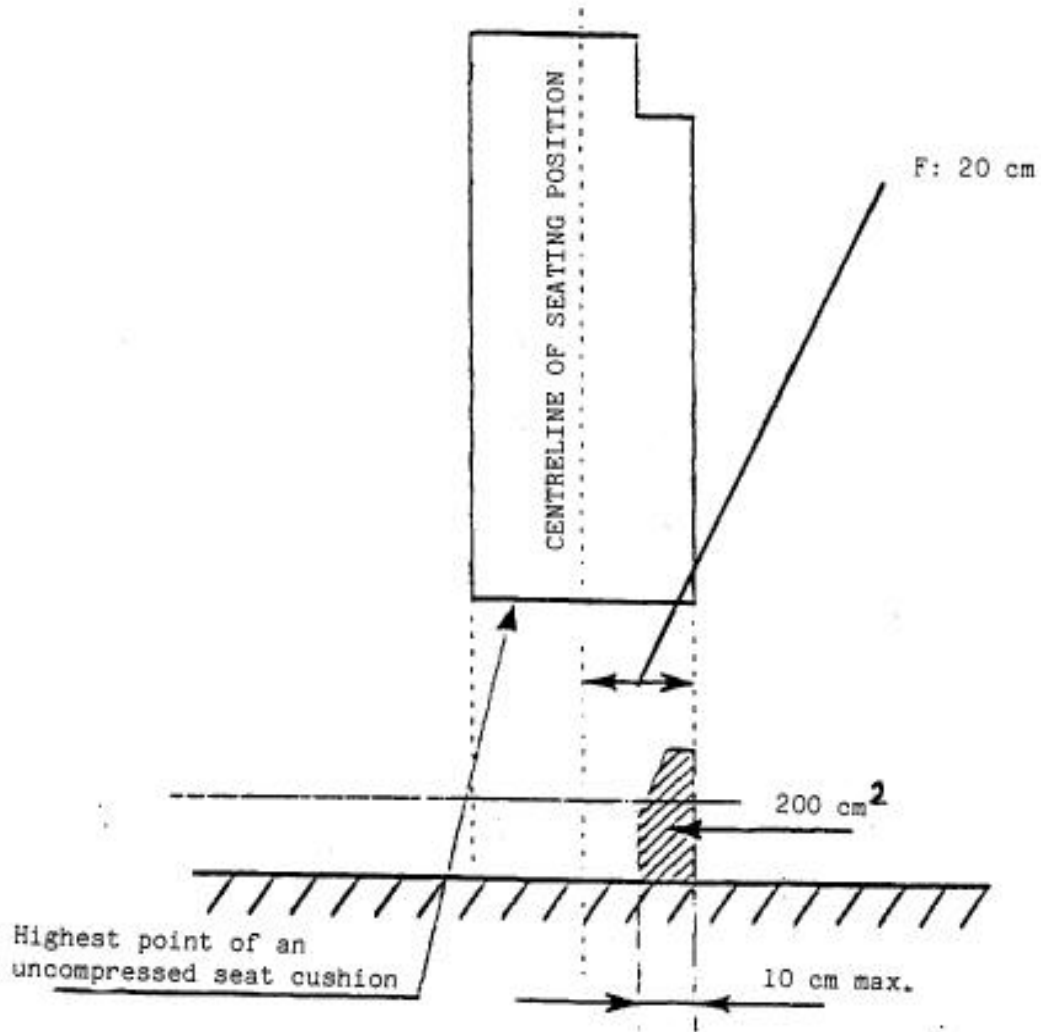

Figure 8

PERMITTED INTRUSION IN LOWER PART OF PASSENGER SPACE

(See paragraph 5.7.8.1.3.3.)



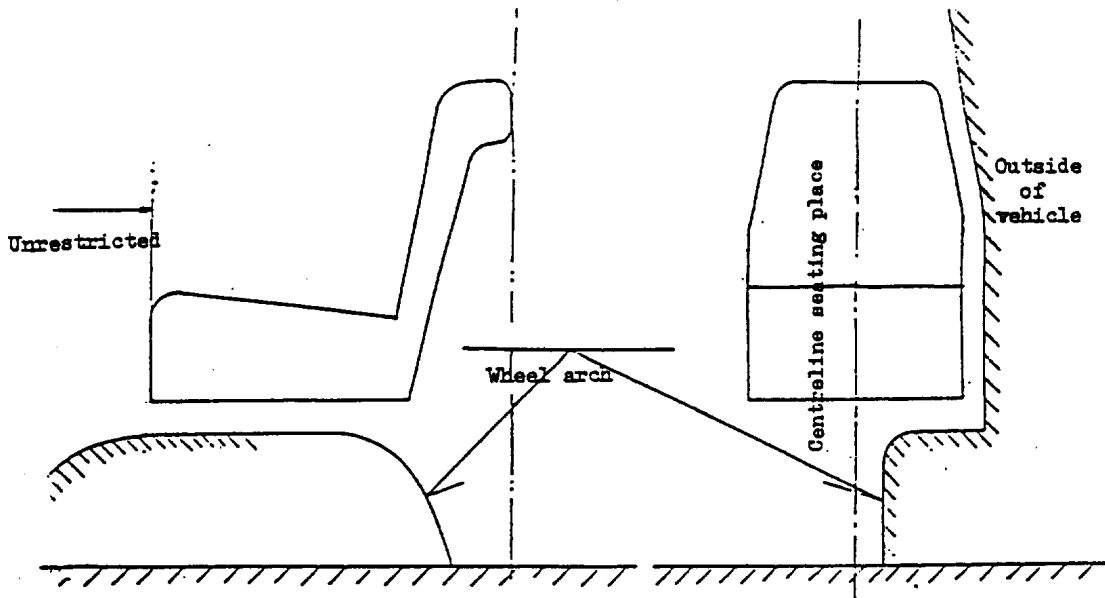

Figure 9
Permitted intrusion of a wheel arch not extending beyond the vertical centreline of the side seat
(See paragraph 5.7.8.1.3.4.)

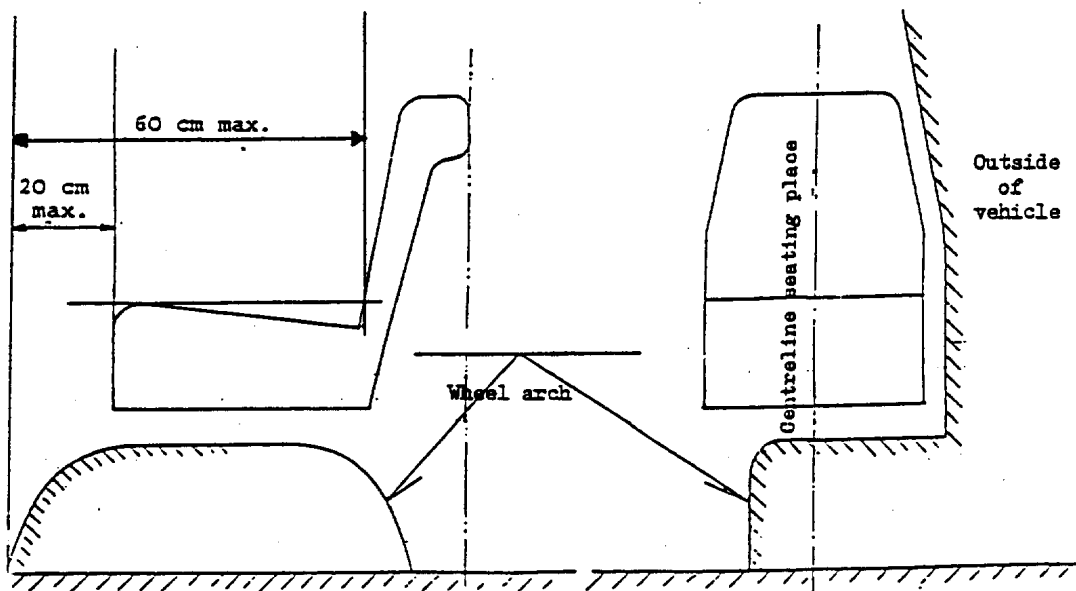

Figure 10
Permitted intrusion of a wheel arch extending beyond the vertical centreline of the side seat
(See paragraph 5.7.8.1.3.4.)

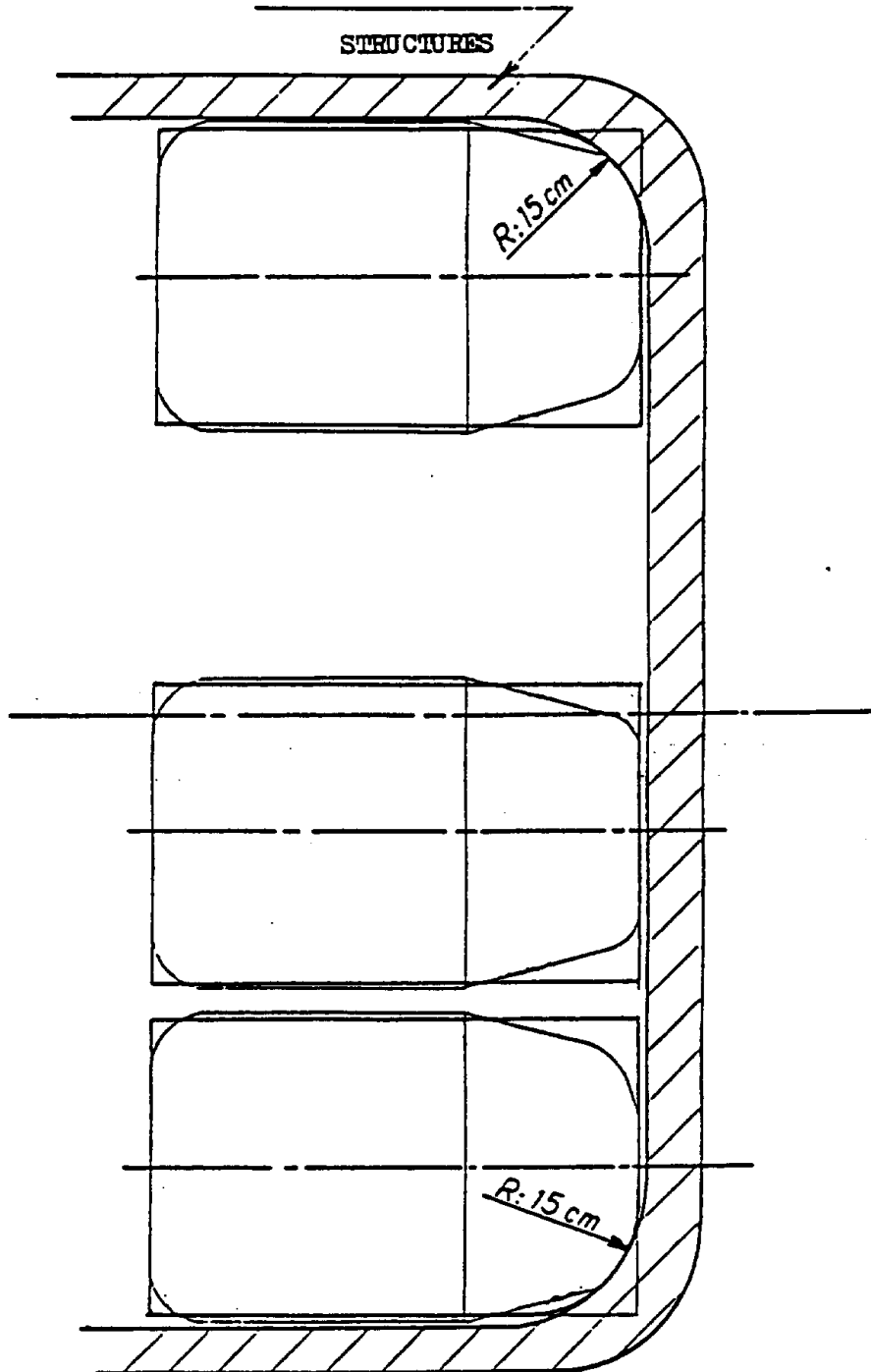

Figure 11

Permitted intrusion at rear corner seats

View of the prescribed area of the seat - (2 side seats at the rear)
(See paragraph 5.7.8.1.4.)

Figure 12

Dimensions of passenger seats
 (See paragraph 5.7.8.2.)

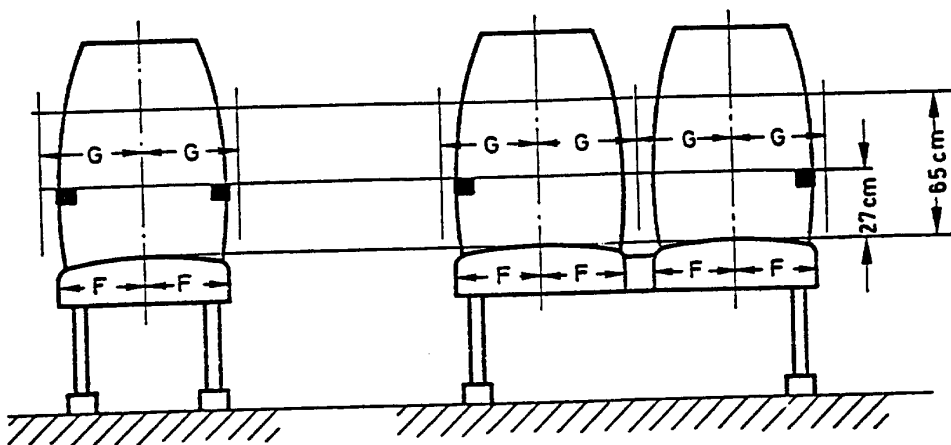

Individual seat

Continuous seat

F (cm) min	G (cm) min	
	continuous seat	Individual seats
20	22.5	25

Figure 13

Permitted intrusion at shoulder height

Transversal section of the minimum available space at shoulder height for a seat adjacent to the wall of the vehicle
 (See paragraph 5.7.8.2.2.)

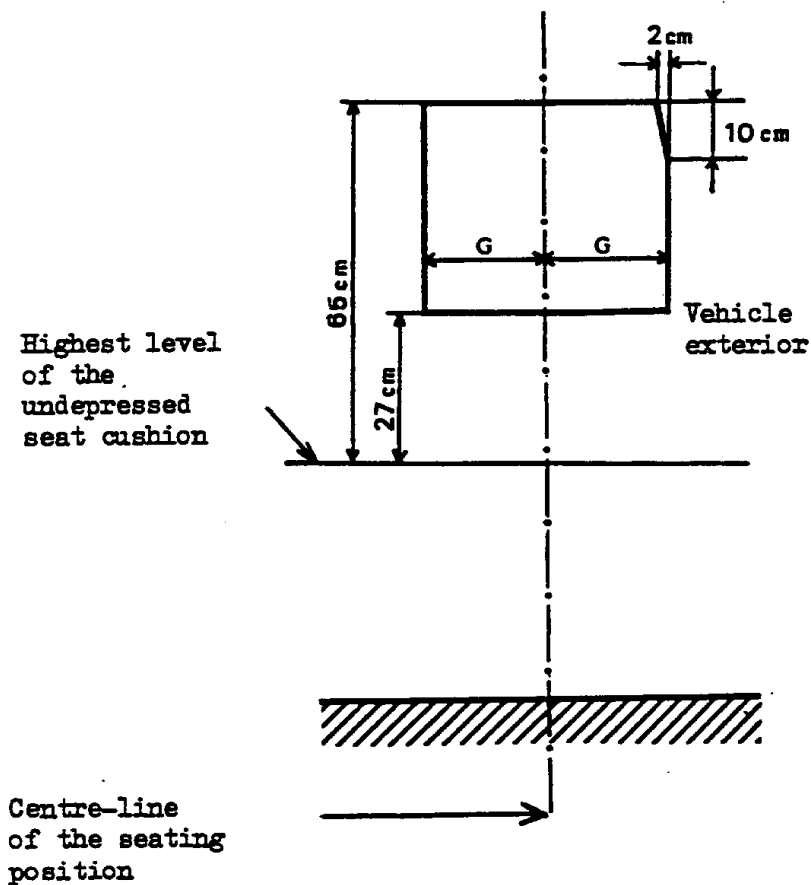

G = (22.5 cm if continuous seat
 (25 cm if individual seat

Figure 14

Seat-cushion depth
(See paragraph 5.7.8.3.)

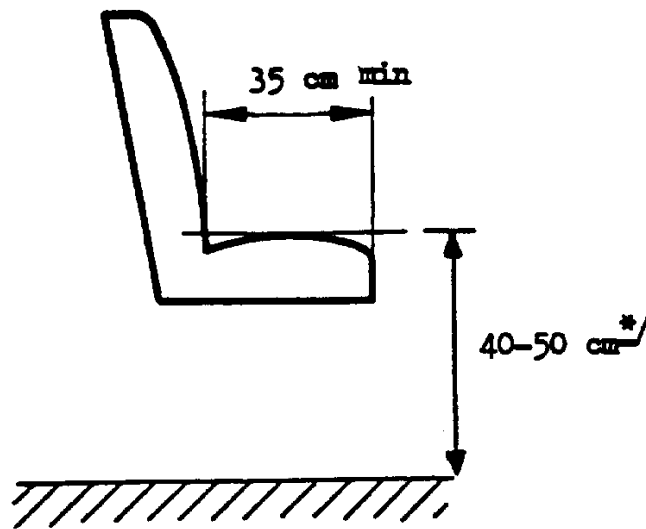

* / 35 cm at wheel arches

Figure 15

Seat spacing
(See paragraph 5.7.8.4.)

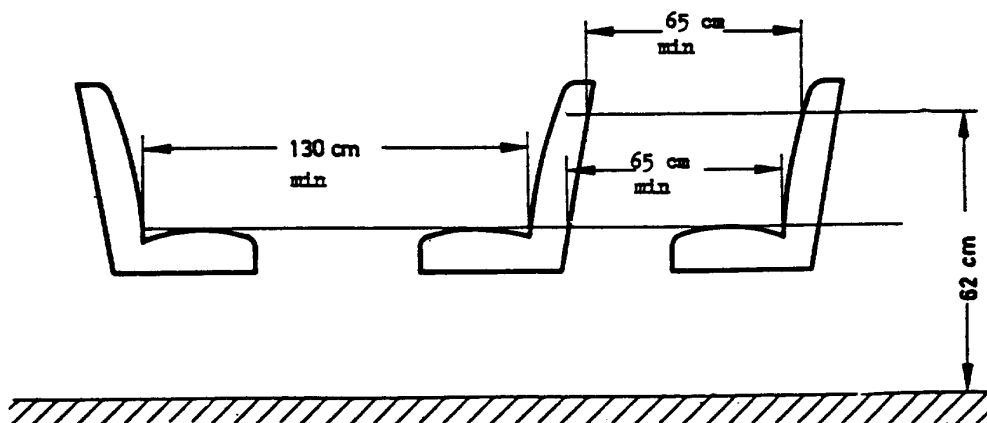
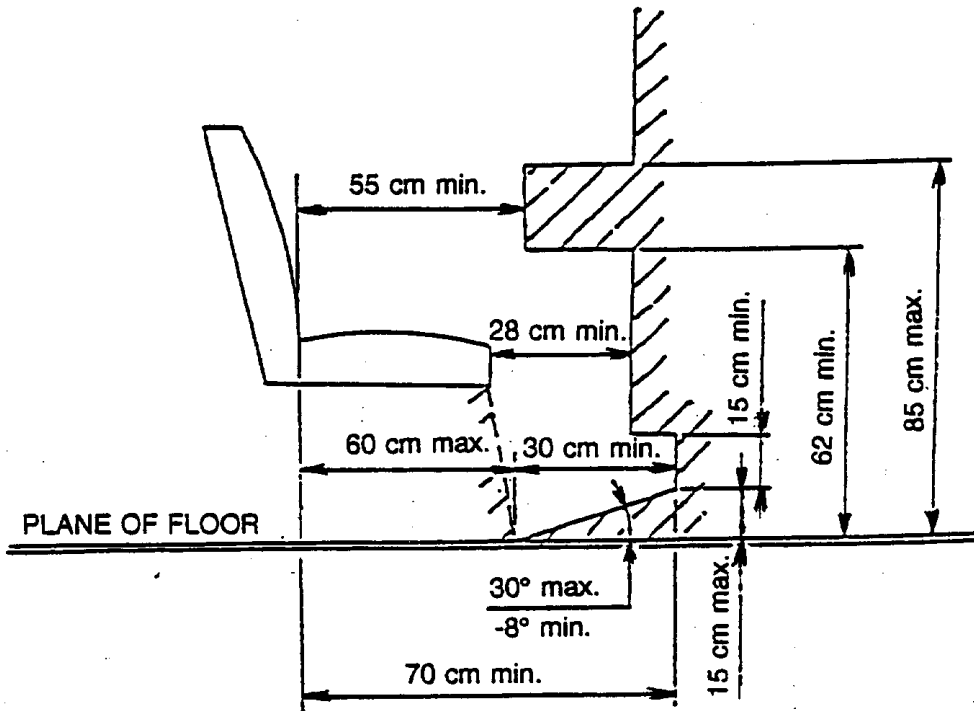

Figure 16

Space for seated passengers



(See paragraph 5.7.8.5.)

Figure 17 (See paragraph 5.7.1.4.)

Service door entry

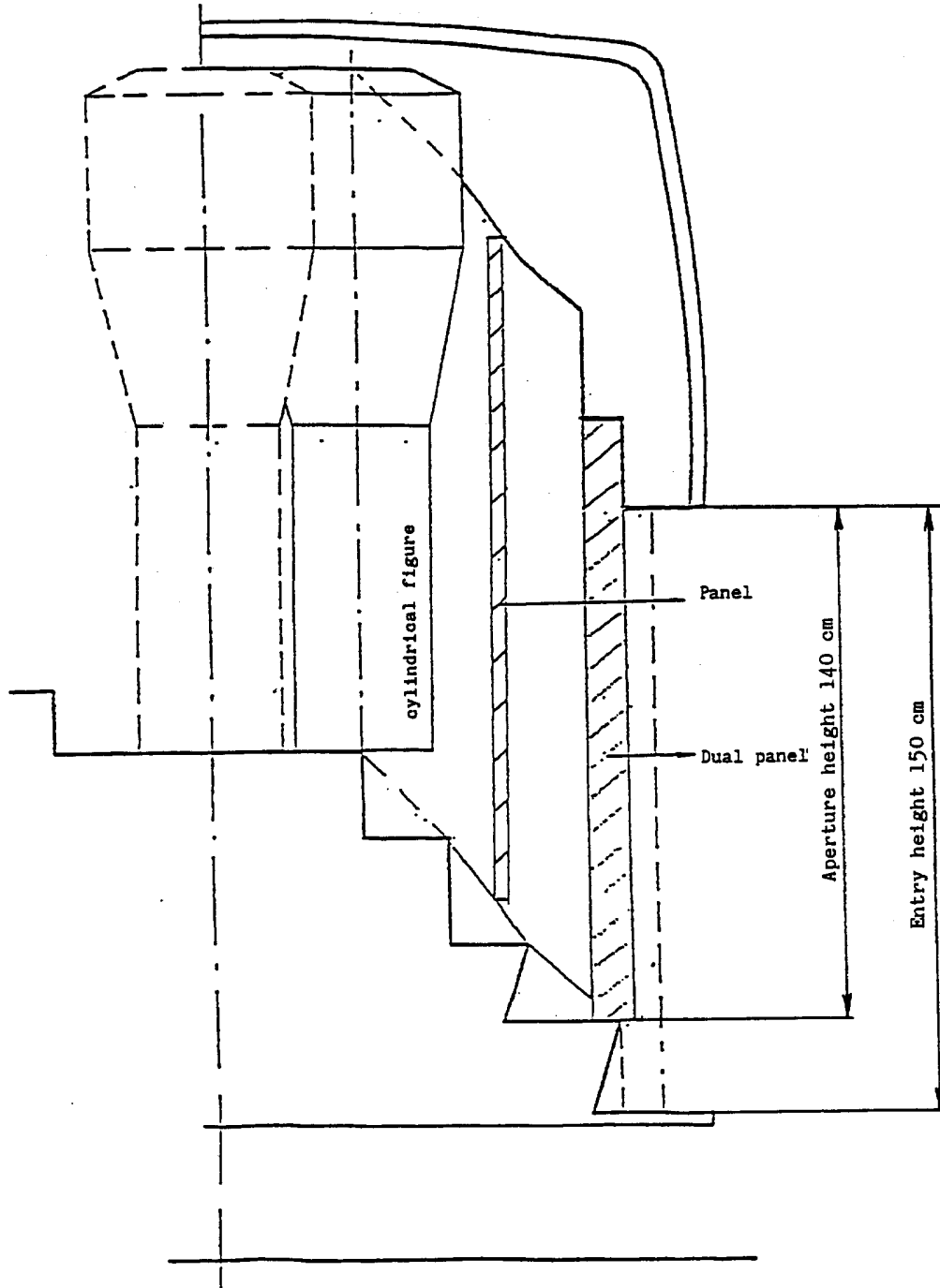

Figure 18

Testing device for siting of handrails and handholds

(See paragraph 5.9.2.1.)

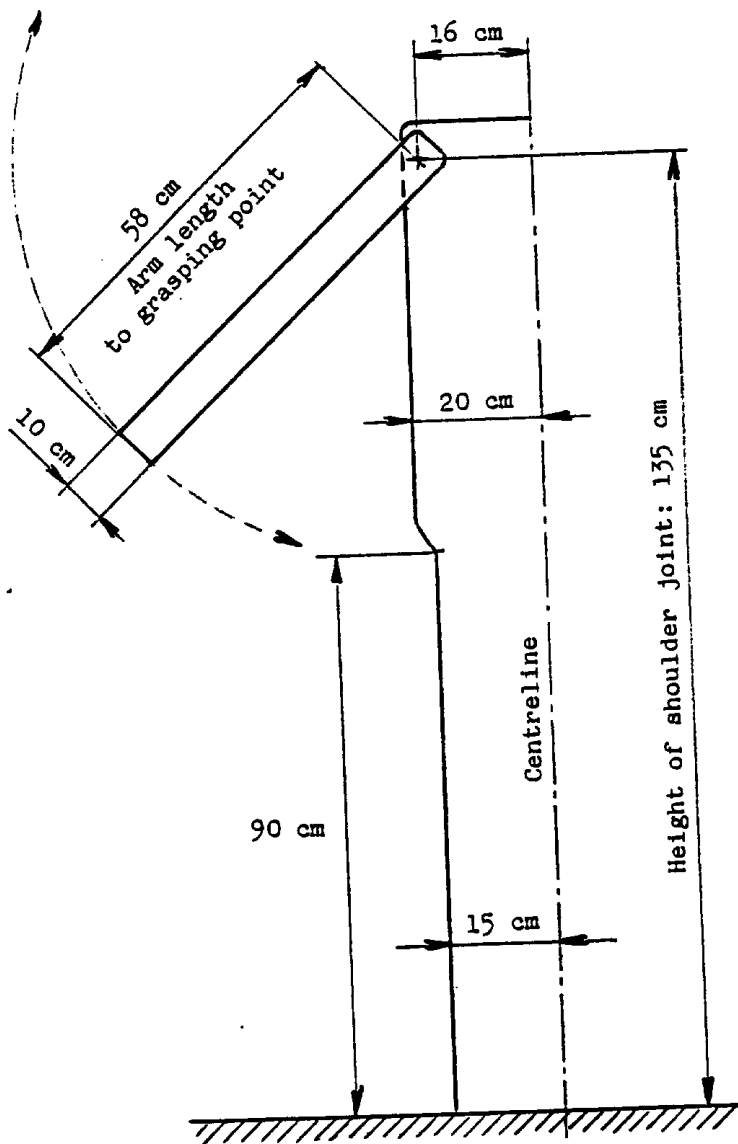

Figure 19
Determination of unobstructed access to door
(See paragraph 5.7.1.10.1.)

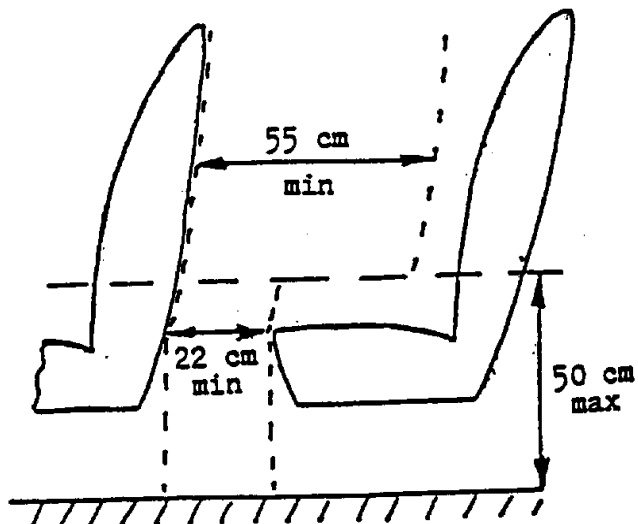
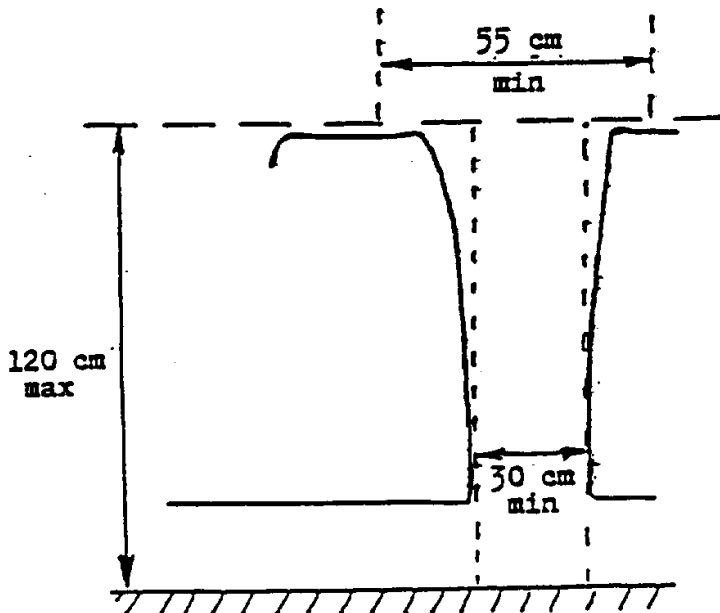

Figure 20
Determination of unobstructed access to door
(See paragraph 5.7.1.10.2.)



Annex 4

(See paragraph 5.6.5.6.2.)

GUIDELINES FOR MEASURING THE CLOSING FORCES OF
POWER-OPERATED DOORS

1. General

The closing of power-operated door is a dynamic process. When a moving door hits an obstacle, the result is a dynamic reaction force, the history of which (in time) depends upon several factors (e.g. mass of the door, acceleration, dimensions).

2. Definitions

2.1. Closing force $F(t)$ is a time function, measured at the closing edges of the door (see paragraph 3.2. below).

2.2. Peak force F_S means the maximum value of the closing force.

2.3. Effective force F_E is the average value of the closing force related to the pulse duration:

$$F_E = \frac{1}{T} \cdot \int_{t_1}^{t_2} F(t) dt$$

2.4. Pulse duration T is the time between t_1 and t_2 :

$$T = t_2 - t_1$$

where t_1 = threshold of sensitivity, where the closing force exceeds 50 N

t_2 = fade-away threshold, where the closing force becomes less than 50 N.

2.5. The relations between the above parameters is shown in figure 1 below (as an example):

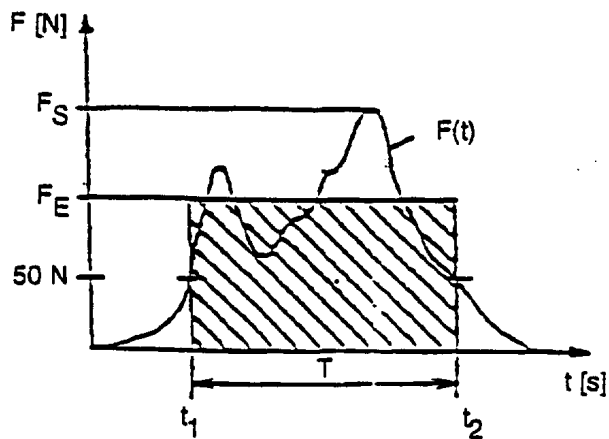

Figure 1

2.6. Clamping force F_C is the arithmetical mean value of the effective forces, measured at the same measuring point subsequently more times:

$$F_C = \frac{\sum_{i=1}^n (F_E)_i}{n}$$

3. Measurements

3.1. Conditions of measurement:

3.1.1. temperature range 10E-30E C.

3.1.2. the vehicle shall stay on a horizontal surface.

3.2. Measurements points shall be:

3.2.1. At the main closing edges of the door:

one in the middle of the door;
 one 150 mm above the lower edge of the door.

3.2.2. In the case of doors equipped with clamping prevention devices for the opening process:

At the secondary closing edges of the door at that point which is considered to be the most dangerous place of clamping.

- 3.3. At least three measurements shall be taken at each of the measuring points to determine the clamping force according to paragraph 2.6. above.
- 3.4. The signal of the closing force shall be recorded by means of a low-pass filter with a limiting frequency of 100 Hz. Both the threshold of sensitivity and the fade-away threshold to limit the pulse duration shall be set at 50 N.
- 3.5. The deviation of the reading from the rated value shall not be more than " 3%.

4. Measuring device

- 4.1. The measuring device shall consist of two parts: one handle and one measuring part which is a load cell (see figure 2).
- 4.2. The load cell shall have the following characteristics:
- 4.2.1. It shall consist of two sliding housings with the outer dimension of 100 mm in diameter and 115 mm in width. Inside the load cell a compression spring shall be fitted between the two housings such that the load cell can be pressed together if an appropriate force is applied.
- 4.2.2. The stiffness of the load cell shall be 10 " 0.2 N/mm. The maximum spring deflection shall be limited to 30 mm so that a maximum peak force of 300 N is achieved.

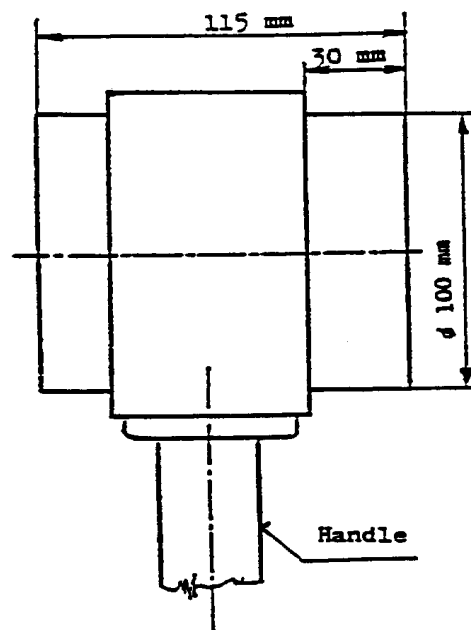

Figure 2