



**Economic and Social  
Council**

Distr.  
GENERAL

TRANS/WP.29/2003/36  
4 April 2003

ENGLISH  
Original: ENGLISH AND FRENCH

**ECONOMIC COMMISSION FOR EUROPE**

INLAND TRANSPORT COMMITTEE

World Forum for Harmonization of Vehicle Regulations (WP.29)  
(One-hundred-and-thirtieth session,  
24-27 June 2003, agenda item 4.2.5.)

PROPOSAL FOR DRAFT 06 SERIES OF AMENDMENTS TO REGULATION No. 14

(Safety-belts anchorages)

Transmitted by the Working Party on Passive Safety (GRSP)

Note: The text reproduced below was adopted by GRSP at its thirty-second session, and is transmitted for consideration to WP.29 and to AC.1. It is based on document TRANS/WP.29/GRSP/2001/14/Rev.2, as amended (TRANS/WP.29/GRSP/32, para. 26 and annex 2).

This document is a working document circulated for discussion and comments. The use of this document for other purposes is the entire responsibility of the user. Documents are also available via the INTERNET:

<http://www.unece.org/trans/main/welcwp29.htm>

The title of the Regulation, amend to read:

"UNIFORM PROVISIONS CONCERNING THE APPROVAL OF VEHICLES WITH REGARD TO SAFETY-BELT ANCHORAGES, ISOFIX ANCHORAGES SYSTEMS AND ISOFIX TOP TETHER ANCHORAGES."

Paragraph 1., amend to read (footnote 1/ not amended):

"..... of categories M and N 1/."

It also applies to ISOFIX anchorages systems and ISOFIX top tether anchorages intended to ISOFIX child restraint systems installed in vehicles of category M1. N1 vehicles fitted with ISOFIX anchorages have also to comply with the provisions of this Regulation."

Paragraph 2.2., amend to read:

" .....to which the safety-belts anchorages and the ISOFIX anchorages systems and ISOFIX top tether anchorages if any are attached ....." "

Insert new paragraphs 2.17. to 2.31., to read:

"2.17. "ISOFIX" is a system for the connection of child restraint systems to vehicles which has two vehicle rigid anchorages, two corresponding rigid attachments on the child restraint system and a mean to limit the pitch rotation of the child restraint system.

2.18. "ISOFIX position" means a system which allows to install:

- a) either an universal ISOFIX forward facing child restraint system as defined in Regulation No. 44,
- b) or a semi-universal ISOFIX forward facing child restraint system as defined in Regulation No. 44,
- c) or a semi-universal ISOFIX rearward facing child restraint system as defined in Regulation No. 44,
- d) or a semi-universal ISOFIX lateral facing position child restraint system as defined in Regulation No. 44,
- d) or a specific vehicle ISOFIX child restraint system as defined in Regulation No. 44.

2.19. "ISOFIX low anchorage" means one 6 mm diameter rigid round horizontal bar, extending from vehicle or seat structure to accept and restrain an ISOFIX child restraint system with ISOFIX attachments.

- 2.20. "ISOFIX anchorages system" means a system made up of two ISOFIX low anchorages which is designed for attaching an ISOFIX child restraint system in conjunction with an anti-rotation device.
- 2.21. "ISOFIX attachment" means one of the two connections, fulfilling the requirements of Regulation No. 44, extending from the ISOFIX child restraint system structure, and compatible with an ISOFIX low anchorage.
- 2.22. "ISOFIX child restraint system" means a child restraint system, fulfilling the requirements of Regulation No. 44, which has to be attached to an ISOFIX anchorages system.
- 2.23. "Static force application device (SFAD)" means a test fixture that engages the vehicle ISOFIX anchorages systems and that is used to verify their strength and the ability of the vehicle or seat structure to limit the rotation in a static test. The test fixture is described in the figures 1 and 2 annex 9.
- 2.24. "Anti-rotation device"
- a) An anti-rotation device for an ISOFIX universal child restraint system consists of the ISOFIX top-tether.
  - b) An anti-rotation device for an ISOFIX semi-universal child restraint system consists of either a top tether, the vehicle dashboard or a support leg intended to limit the rotation of the restraint during a frontal impact.
  - c) For ISOFIX, universal and semi-universal, child restraint systems the vehicle seat itself does not constitute an anti-rotation device.
- 2.25. "ISOFIX top tether anchorage" means a feature, such as a bar, located in a defined zone, designed to accept an ISOFIX top tether strap connector and transfer its restraint force to the vehicle structure.
- 2.26. "ISOFIX top tether connector" means a device intended to be attached to an ISOFIX top tether anchorage.
- 2.27. "ISOFIX top tether hook" means an ISOFIX top tether connector typically used to attach an ISOFIX top tether strap to an ISOFIX top tether anchorage as defined in figure 3 of annex 9 of this Regulation.
- 2.28. "ISOFIX top tether strap" means a webbing strap (or equivalent) which extends from the top of an ISOFIX child restraint system to the ISOFIX top tether anchorage, and which is equipped with an adjustment device, a tension-relieving device, and an ISOFIX top tether connector.
- 2.29. "A guidance device" is intended to help the person installing the ISOFIX child restraint system by physically guiding the ISOFIX attachments on the ISOFIX child

restraint into correct alignment with the ISOFIX low anchorages to facilitate engagement.

2.30 "ISOFIX marking fixture" means something that informs someone wishing to install an ISOFIX child restraint system of the ISOFIX positions in the vehicle and the position of each ISOFIX corresponding ISOFIX anchorages systems.

2.31. "A child restraint fixture" means a fixture according to one out of the seven ISOFIX size classes defined in paragraph 4. of annex 17 – appendix 2 of Regulation No. 16 and particularly whose dimensions are given from figure 1 to figure 6 in the previous mentioned paragraph 4. Those child restraint fixtures (CRF) are used in Regulation No. 16, to check what are the ISOFIX child restraint systems size classes which can be accommodated on the vehicle ISOFIX positions. Also one of the CRF, the so-called ISO/F2 (B) which is described in figure 2 of the previous mentioned paragraph 4., is used in this Regulation to check the location and the possibility of access to any ISOFIX anchorages system."

Paragraph 3.1., amend to read:

".....with regard to the belt anchorages, the ISOFIX anchorages systems and the ISOFIX top tether anchorages if any shall be submitted ....."

Paragraph 3.2.1., amend to read:

"..... showing the positions of the belt anchorages, of the effective belt anchorages (where appropriate), of the ISOFIX anchorages systems and of ISOFIX top tether anchorages if any and detailed drawings of the belt anchorages, of the ISOFIX anchorages systems if any, of the ISOFIX top tether anchorage if any, and of the point "

Paragraph 3.2.2., amend to read:

".....of the belt anchorages, of the ISOFIX anchorages systems and of ISOFIX top tether anchorages if any;"

Paragraph 3.2.3., amend to read:

".....of the belt anchorages, of the ISOFIX anchorages systems and ISOFIX top tether anchorages if any;"

Paragraph 3.2.4., amend to read:

".....of belt anchorages, of the ISOFIX anchorages systems and of ISOFIX top tether anchorages if any affixed to the seat structure;"

Paragraph 3.3., amend to read:

".....for the belt anchorages test, for the ISOFIX anchorages systems and for ISOFIX top tether anchorages test if any, by the technical ....." "

Paragraph 4.2., amend to read:

".....Its first two digits (at present 06, corresponding to the 06 series of amendments) ....." "

Paragraph 4.4.1. footnote 2/, amend to read:

" ... 10 for Serbia and Montenegro, ... 35 (vacant), 36 for Lithuania, ... 38 (vacant), 39 for Azerbaijan, ..... 46 for Ukraine, 47 for South Africa and 48 for New Zealand. ....  
"

Insert new paragraphs 5.2.2. to 5.2.4.4., to read:

"5.2.2. Any ISOFIX anchorages system and any ISOFIX top tether anchorage, installed or intended to be installed, for ISOFIX child restraint systems shall be so designed, made and situated as to:

5.2.2.1. Any ISOFIX anchorages system and any top tether anchorage shall enable the vehicle, in normal use, to comply with the provisions of this Regulation.

Any ISOFIX anchorages system and ISOFIX top tether anchorage which could be added on any vehicle shall also comply with the provisions of this Regulation. Consequently, such anchorages shall be described on the application document for type approval.

5.2.2.2 ISOFIX anchorages system and ISOFIX top tether anchorage resistance are designed for any ISOFIX child restraint systems of group of mass 0; 0+; 1 as defined in Regulation No. 44.

5.2.3 ISOFIX anchorage systems, design and positioning:

5.2.3.1. Any ISOFIX anchorages system shall be 6 mm ± 0.1 mm diameter transverse horizontal rigid bar(s) which cover(s) two zones of 25 mm minimum effective length located on the same axis as defined in figure 4 annex 9.

5.2.3.2. Any ISOFIX anchorages system installed on a vehicle seating position shall be located not less than 120 mm behind the design H-point as determined in annex 4 to this Regulation, measured horizontally and up to the centre of the bar.

5.2.3.3. For any ISOFIX anchorages system installed in the vehicle, it shall be verified the possibility to attach the ISOFIX child restraint fixture "ISO/F2" (B) described in Regulation No. 16 (annex 17, appendix 2, figure 2).

5.2.3.4. The bottom surface of the fixture "ISO/F2" (B) as defined in Regulation No. 16 (annex 17, appendix 2, figure 2), shall have attitude angles within the following limits, angles measured relatively to the vehicle reference planes as defined in annex 4 appendix 2 to this Regulation:

Pitch:  $15^{\circ} \pm 10^{\circ}$ ,

Roll:  $0^{\circ} \pm 5^{\circ}$ ,

Yaw:  $0^{\circ} \pm 10^{\circ}$

5.2.3.5. ISOFIX anchorage systems shall be permanently in position or storable. In case of storable anchorages, the requirements relating to ISOFIX anchorages system shall be fulfilled in the deployed position.

5.2.3.6. Each ISOFIX low anchorage bar (when deployed for use) or each permanently installed guidance device shall be visible, without the compression of the seat cushion or seat back, when the bar or the guidance device is viewed, in a vertical longitudinal plane passing through the centre of the bar or of the guidance device, along a line making an upward angle of 30 degrees with a horizontal plane.

As an alternative to the above requirement, the vehicle shall be permanently marked adjacent to each bar or guidance device. This marking shall consist in one of the following, at the choice of the manufacturer."

5.2.3.6.1. As a minimum, the symbol of annex 9, figure 12 consisting of a circle with a diameter of minimum 13 mm and containing a pictogram, meeting the following conditions:

- a) the pictogram shall contrast with the background of the circle;
- b) the pictogram shall be located close to each bar of the system;

5.2.3.6.2. The word "ISOFIX" in capital letters of at least 6 mm height.

5.2.4. ISOFIX top tether anchorages, design and positioning:

At the request of the car manufacturer, methods described in paragraphs 5.2.4.1. and 5.2.4.2. can be used alternatively.

Method described in paragraph 5.2.4.1. can only be used if the ISOFIX position is located on a vehicle seat.

5.2.4.1. Subject to paragraph 5.2.4.3., the portion of each ISOFIX top tether anchorage that is designed to bind with an ISOFIX top tether connector shall be located not further than 2000 mm far from the shoulder reference point and within the shaded zone - as shown in figures 6 to 11 of annex 9 - of the designated seating position for which it

is installed, with the reference of a template described in SAE J 826 (July 1995) and shown in figure 5 annex 9, according to the following conditions:

- 5.2.4.1.1. The "H" point of the template is located at the unique design "H" point of the full downward and full rearward position of the seat, except that the template is located laterally midway between the two ISOFIX lower anchorages;
  - 5.2.4.1.2. The torso line of the template is at the same angle to the transverse vertical plane as the seat back in its most upright position, and
  - 5.2.4.1.3. The template is positioned in the vertical longitudinal plane that contains the H-point of the template.
- 5.2.4.2. The ISOFIX top tether anchorage zone may be alternatively located with the aid of the Fixture "ISO/F2" (B), as defined in Regulation No. 16 (annex 17, appendix 2, figure 2), in an ISOFIX position equipped with ISOFIX low anchorages as shown in figure 11 of annex 9. In the side view, the ISOFIX top tether anchorage shall lie behind a lateral plane containing the Fixture "ISO/F2" (B) vertical reference line and below a lateral plane passing through the intersection of the "ISO/F2" (B) fixture reference line and the plane containing the underside of the seat top bar, and extending rearward at an angle of 45° above the horizontal.

In the plan view, the ISOFIX top tether anchorage zone shall lie between the planes extending rearward and laterally from the tether reference point, and separated by an angle of 90°. Further, the ISOFIX top tether anchorage shall be more than 200 mm but not more than 2000 mm from the origin of the ISOFIX top tether strap on the rear face of the "ISO/F2" (B) fixture, measured along the strap when it is drawn over the seat back to the ISOFIX top tether anchorage.

- 5.2.4.3. The portion of the ISOFIX top tether anchorage in a vehicle that is designed to bind with the ISOFIX top tether connector may be located outside the shaded zones referred to paragraphs 5.2.4.1. or 5.2.4.2. if a location within a zone is not appropriate and the vehicle is equipped with a routing device that,
  - 5.2.4.3.1. ensures that the ISOFIX top tether strap functions as if the portion of the anchorage designed to bind with the ISOFIX top tether anchorage were located within the shaded zone; and,
  - 5.2.4.3.2. is at least 65 mm behind the torso line, in case of a non-rigid webbing-type routing device or a deployable routing device, or at least 100 mm behind the torso line, in the case of a fixed rigid routing device; and,
  - 5.2.4.3.3. when tested after being installed as it is intended to be used, the device is of sufficient strength to withstand, with the ISOFIX top tether anchorage the load referred to in paragraph 6.6. of this Regulation.

- 5.2.4.4. The ISOFIX top tether anchorage shall have dimensions to permit the attachment of an ISOFIX top tether hook as specified in figure 3.

Clearance shall be provided around each ISOFIX top tether anchorage to allow latching and unlatching to it. For each ISOFIX top tether anchorage under a cover, the cover shall be identified by for example one of the symbols or the mirror image of one of the symbols set out in figure 13 of annex 9; the cover shall be removable without the use of tools.”

Insert new paragraphs 5.3.10. to 5.3.10.6., to read:

"5.3.10. Minimum number of ISOFIX positions to be provided.

5.3.10.1. Any vehicle of category M1 must be equipped at least with two ISOFIX positions.

At least two of the ISOFIX positions shall be equipped both with an ISOFIX anchorages system and an ISOFIX top tether anchorage.

The type and number of ISOFIX fixtures, defined in Regulation No. 16, which can be installed on each ISOFIX position are defined in Regulation No. 16.

5.3.10.2. Notwithstanding paragraph 5.3.10.1. if a vehicle is only equipped with one seat row, no ISOFIX position is required.

5.3.10.3. Notwithstanding paragraph 5.3.10.1. at least one of the two ISOFIX positions systems shall be installed at the second seat row.

5.3.10.4. If an ISOFIX anchorages system is installed at a front seating position protected with a frontal airbag, a de-activation device for this airbag shall be fitted.

5.3.10.5. Notwithstanding paragraph 5.3.10.1. in case of integrated "built in" child restraint system(s) the number of ISOFIX positions to be provided shall be at least two minus the number of the integrated "built in" child restraint system(s) of mass groups 0, or 0+, or 1.

5.3.10.6. Notwithstanding the provision of the paragraph 5.3.10.1., convertible vehicles as defined in annex 7, paragraph 8.1. of the Consolidated Resolution on the Construction of Vehicles (R.E.3) \*/ with more than one seat row shall be fitted with at least two ISOFIX low anchorages. In case where an ISOFIX top tether anchorage is provided on such vehicles, it shall comply with the suitable provisions of this Regulation.

---

\*/ Document TRANS/WP29/78/Rev.1/Amend.2"

Paragraph 5.3.10. (former), renumber as paragraph 5.3.11.



Paragraphs 6.1. and 6.2., amend to read:

"6.1. General for seat belt anchorages tests.

6.2. Securing the vehicle for seat belt anchorages tests and for ISOFIX anchorages tests."

Paragraph 6.2.1., amend to read:

".....as to strengthen the seat belt anchorages or the ISOFIX anchorages and their anchorage area ....." "

Paragraph 6.3., amend to read:

"6.3. General test requirements for seat belt anchorages."

Paragraph 6.4., amend to read:

"6.4. Particular test requirements for seat belt anchorages."

Insert new paragraphs 6.6. to 6.6.5.1., to read:

"6.6. Static test requirements.

6.6.1. The strength of the ISOFIX anchorage systems shall be tested applying the forces, as prescribed in paragraph 6.6.4.3., to the static force application device (SFAD) with ISOFIX attachments well engaged.

In case of ISOFIX top tether anchorage an additional test shall be performed as prescribed in paragraph 6.6.4.4.

All the ISOFIX positions of a same seat row, which can be used simultaneously, shall be tested simultaneously.

6.6.2. The test may be carried out either on a completely finished vehicle or on sufficient parts of the vehicle so as to be representative of the strength and rigidity of the vehicle structure.

Windows and doors may be fitted or not and closed or not.

Any fitting normally provided and likely to contribute to the vehicle structure may be fitted.

The test may be restricted to the ISOFIX position relating to only one seat or group of seats on the condition that:

- a) The ISOFIX position concerned have the same structural characteristics as the ISOFIX position relating to the other seats or group of seats and,
- b) Where such ISOFIX positions are fitted totally or partially on the seat or group of seats, the structural characteristics of the seat or group of seats are the same as those for the other seats or groups of seats.

6.6.3. If the seats and head restraint are adjustable, they shall be tested in the position defined by the technical service within the limited range prescribed by the car manufacturer as provided in appendix 3 of annex 17 of Regulation No. 16.

6.6.4. Forces, directions and excursion limits.

6.6.4.1. A force of  $135\text{ N} \pm 15\text{ N}$  shall be applied to the centre of the lower front crossbar of the SFAD in order to adjust the fore-aft position of the SFAD rearward extension to remove any slack or tension between the SFAD and its support.

6.6.4.2. Forces shall be applied to the static force application device (SFAD) in forward and oblique directions according to table 1.

Table 1: Directions of test forces

Forward	$0^\circ \pm 5^\circ$	$8\text{ kN} \pm 0.25\text{ kN}$
Oblique	$75^\circ \pm 5^\circ$ (to both sides of straight forward, or if any worst case side, or if both side are symmetric, only one side)	$5\text{ kN} \pm 0.25\text{ kN}$

Each of these test may be performed on different structures if the manufacturer so requests.

Forces in the forward direction shall be applied with an initial force application angle of  $10 \pm 5^\circ$  above the horizontal. Oblique forces shall be applied horizontally  $0^\circ \pm 5^\circ$ . A pre-load force of  $500\text{ N} \pm 25\text{ N}$  shall be applied at the prescribed loading point X indicated in figure 2 annex 9. Full application of the force shall achieved within a period of 2 s or less. The force shall be maintained for a minimum period of 0.2 s.

All measurements shall be made according to ISO 6487 with CFC of 60 Hz or any equivalent method.

6.6.4.3. Tests of ISOFIX anchorages system only:

6.6.4.3.1. Forward direction force test:

Horizontal longitudinal excursion (after pre-load) of point X of SFAD during application of the  $8 \text{ kN} \pm 0.25 \text{ kN}$  force shall be limited to 125 mm and permanent deformation including partial rupture or breakage of any ISOFIX low anchorage or surrounding area shall not constitute failure if the required force is sustained for the specified time.

6.6.4.3.2. Oblique direction force test:

Excursion in the direction of the force (after pre-load) of point X of SFAD during application of the  $5 \text{ kN} \pm 0.25 \text{ kN}$  force shall be limited to 125 mm and permanent deformation including partial rupture or breakage of any ISOFIX low anchorage or surrounding area shall not constitute failure if the required force is sustained for the specified time.

6.6.4.4. Test of ISOFIX anchorages systems and ISOFIX top tether anchorage:

A tension pre-load of  $50 \text{ N} \pm 5 \text{ N}$  must be applied between the SFAD and the top-tether anchorage. Horizontal excursion (after pre-load) of point X during application of the  $8 \text{ kN} \pm 0.25 \text{ kN}$  force shall be limited to 125 mm and permanent deformation including partial rupture or breakage of any ISOFIX low anchorage and top tether anchorage, or surrounding area shall not constitute failure if the required force is sustained for the specified time.

Table 2: Excursions limits

Force direction	Maximum excursion of point X of SFAD
Forward	125 mm longitudinal
Oblique	125 mm force direction

6.6.5. Additional forces.

6.6.5.1. Seat inertia forces.

For the installation position where the load is transferred into a vehicle seat assembly, and not directly into the vehicle structure, a test shall be carried out to ensure that the strength of the vehicle seat anchorages to the vehicle structure is sufficient. In this test, a force equal to 20 times the mass of the relevant parts of the seat assembly shall be applied horizontally and longitudinally in a forward direction to the seat or the relevant part of the seat assembly corresponding to the physical effect of the mass of the seat in question to the seat anchorages. The determination of the additional applied load or loads and the load distribution shall be made by the manufacturer and agreed by the Technical Service.

At the request of the manufacturer, the additional load can be applied at the X point of SFAD during the static tests described above.

If the top tether anchorage is integrated to the vehicle seat, this test shall be performed with the ISOFIX top tether strap.

No breakage shall occur and excursion requirements given in the table 2 have to be fulfilled.

NOTE: This test does not have to be performed in case of any anchorage of the vehicle safety-belt system is integrated to the vehicle seat structure, and the vehicle seat is already tested and approved to meet the anchorage load tests required by this Regulation for adult passenger restraint."

Paragraph 7., amend to read:

"INSPECTION DURING AND AFTER STATIC TESTS FOR SAFETY-BELT ANCHORAGES."

Paragraph 9., amend to read:

".....with regard to details affecting the characteristics of the safety-belt anchorages and the ISOFIX anchorages system and ISOFIX top tether anchorage."

Paragraph 10., amend to read:

"..... complied with or if its safety-belt anchorages or the ISOFIX anchorages system and ISOFIX top tether anchorage failed to pass the checks prescribed ..... "

Paragraph 12.1., amend to read:

"..... a type of safety-belt anchorages or a type of ISOFIX anchorages system and ISOFIX top tether anchorage approved in accordance with this Regulation .... "

Paragraph 14.1., amend to read:

"14.1. As from the official date of entry into force of the 06 series of amendments, no contracting Party ..... as amended by the 06 series of amendments."

Paragraph 14.2., amend to read:

"14.2. As from 2 years after the enter into force of the 06 series of amendments to this Regulation, Contracting parties applying this Regulation shall grant ECE type approvals only if the requirements of this Regulation, as amended by the 06 series of amendments, are satisfied."

Paragraph 14.3., amend to read:

"14.3. As from 7 years after the enter into force of the 06 series of amendments to this Regulation, Contracting parties applying this Regulation may refuse to recognize approvals which were not granted in accordance with the 06 series of amendments to this Regulation."

Annex 1.

The subtitle, amend to read:

"..... of a vehicle type with regard to safety-belt anchorages and ISOFIX anchorages systems and ISOFIX top tether anchorage if any pursuant to ....."

Item 19., amend to read:

"... drawings, diagrams and plans of the belt anchorages, ISOFIX anchorages systems, of the top tether anchorages if any, and of the vehicle structure;"

"... photographs of the belt anchorages, of the ISOFIX anchorages systems, of the top tether if any, and of the vehicle structure."

Annex 2, in the examples of the approval marks and in the captions below amend the approval number "052439" to read "062439" (3 times, related to Regulation No. 14). In addition, in the caption below Model A of the approval mark amend the words "05 series of amendments" to read "06 series of amendments". The caption below Model B of the approval mark amend to read as follows (footnote \*/not modified):

"... on the dates on which these approvals were granted Regulation No. 14 included the 06 series of amendments and Regulation No. 24 was in its 03 series of amendments."

Replace the current reference "14R - 052439" situated on the right of the second drawing of the approval mark by the following one "14R - 062439".

Insert a new annex 9, to read:

"Annex 9

ISOFIX ANCHORAGES SYSTEMS AND ISOFIX TOP TETHER ANCHORAGES

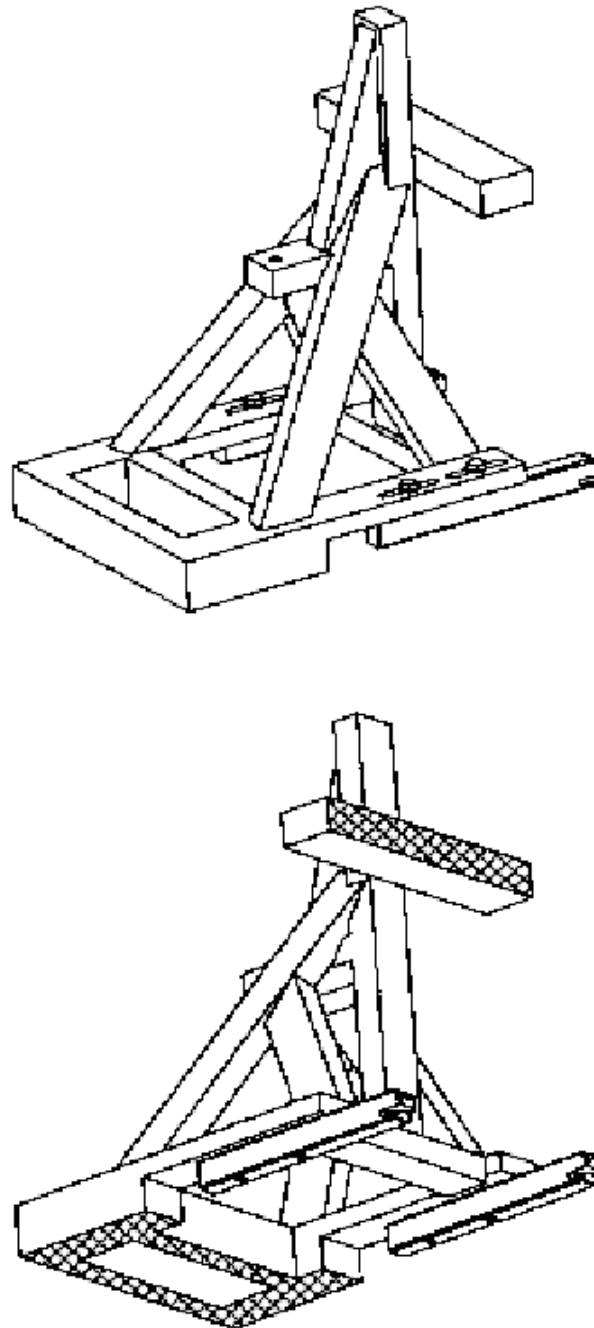
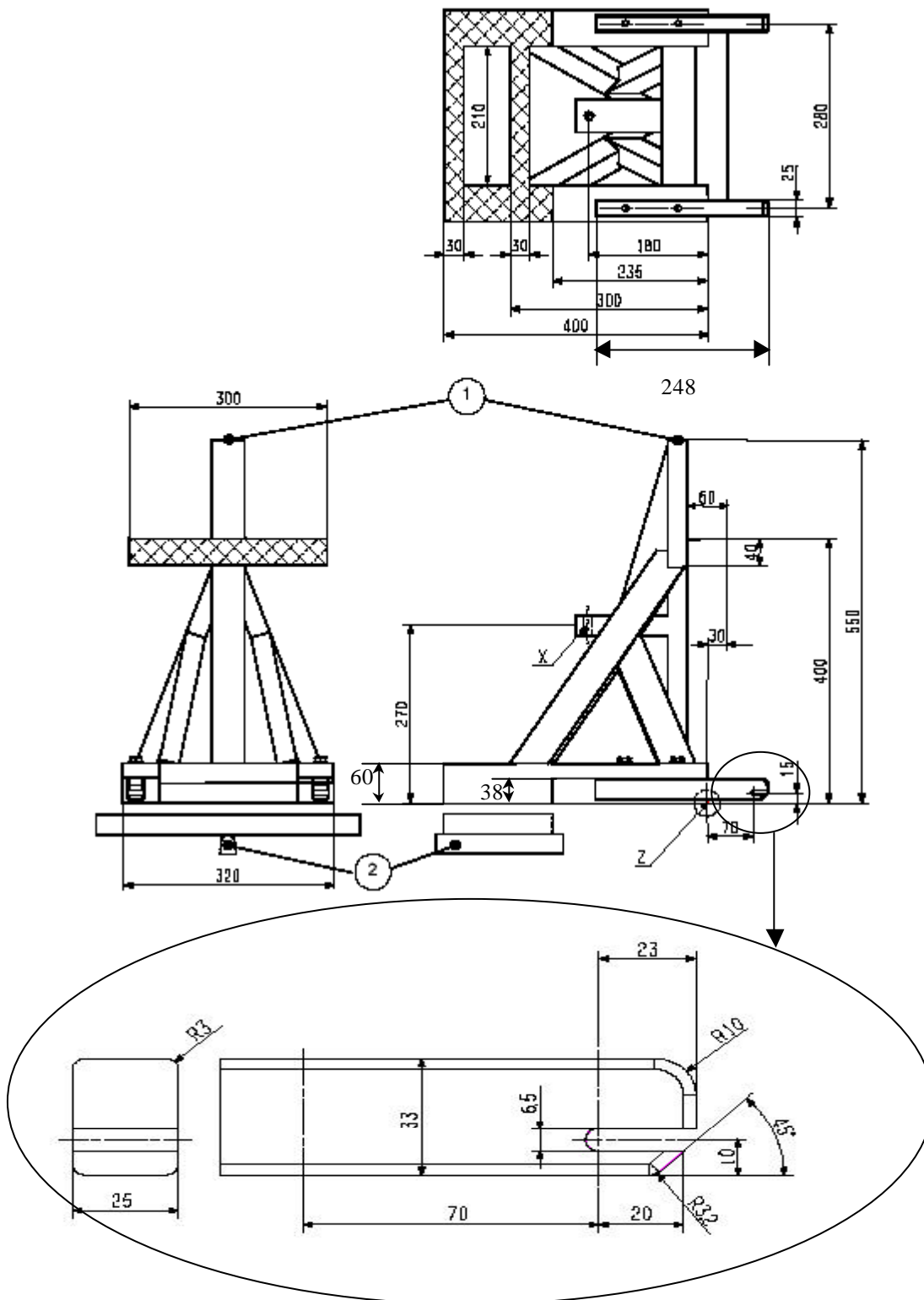

Figure 1: Static force application device (SFAD), isometric views

Dimensions in millimetres



Key

- 1 Top tether attachment point
- 2 Pivot attachment for stiffness testing as described below.

Figure 2: Static force application device (SFAD), dimensions

Stiffness of SFAD: When attached to rigid anchorage bar(s) with the front cross member of the SFAD supported by a rigid bar that is held at the centre by a longitudinal pivot 25 mm below the SFAD base (to allow bending and twisting of the SFAD base) the movement of point X shall not be greater than 2 mm in any direction when forces are applied in accordance with table No. 1 of paragraph 6.6.4. of this Regulation. Any deformation of the ISOFIX anchorages system shall be excluded from the measurements



Dimensions in millimetres

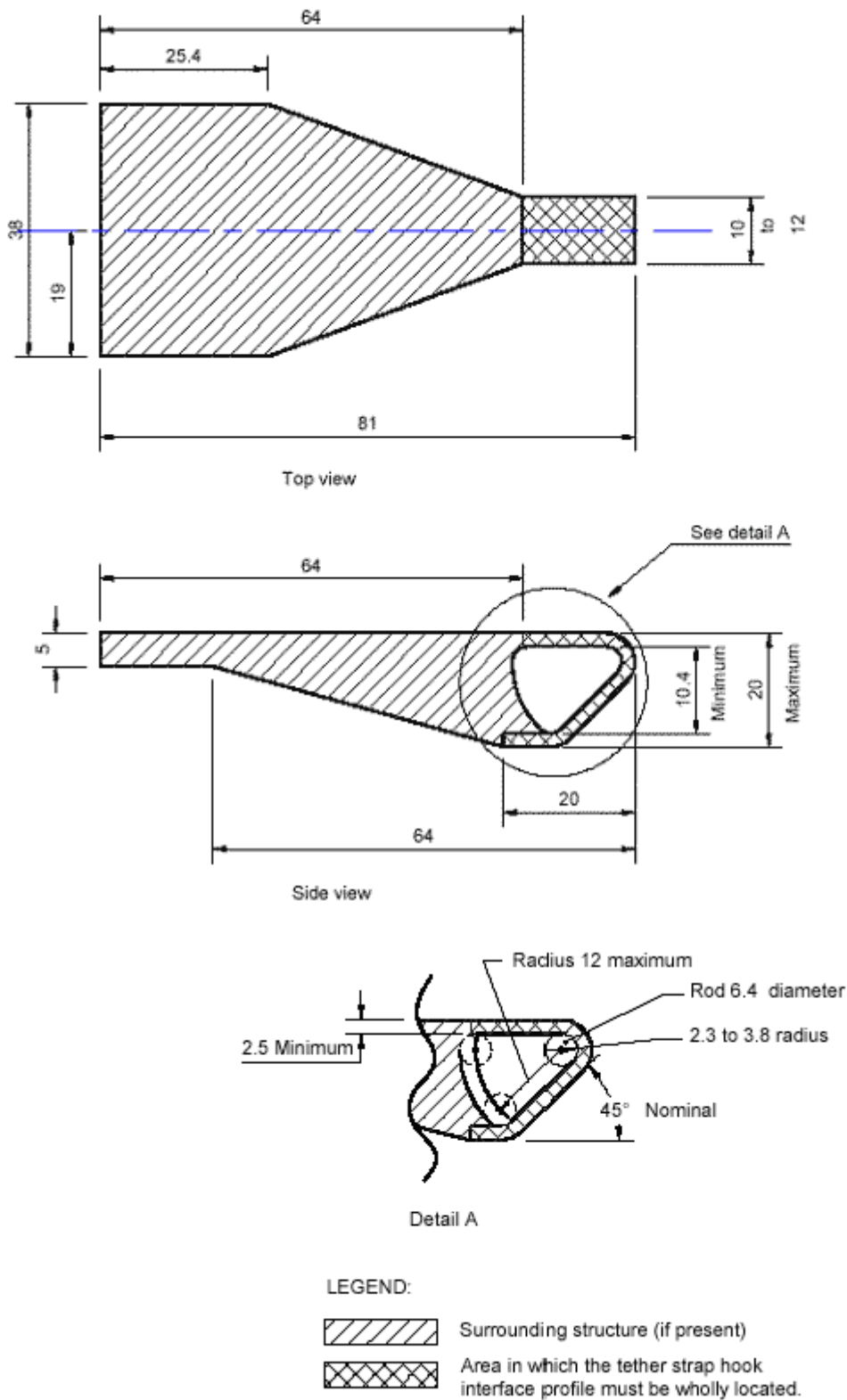

Figure 3: ISOFIX Top tether connector (hook type) dimensions

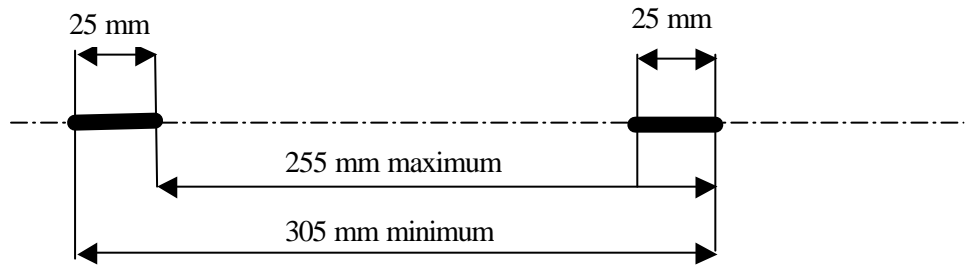

Figure 4: Distance between both low anchorage zones

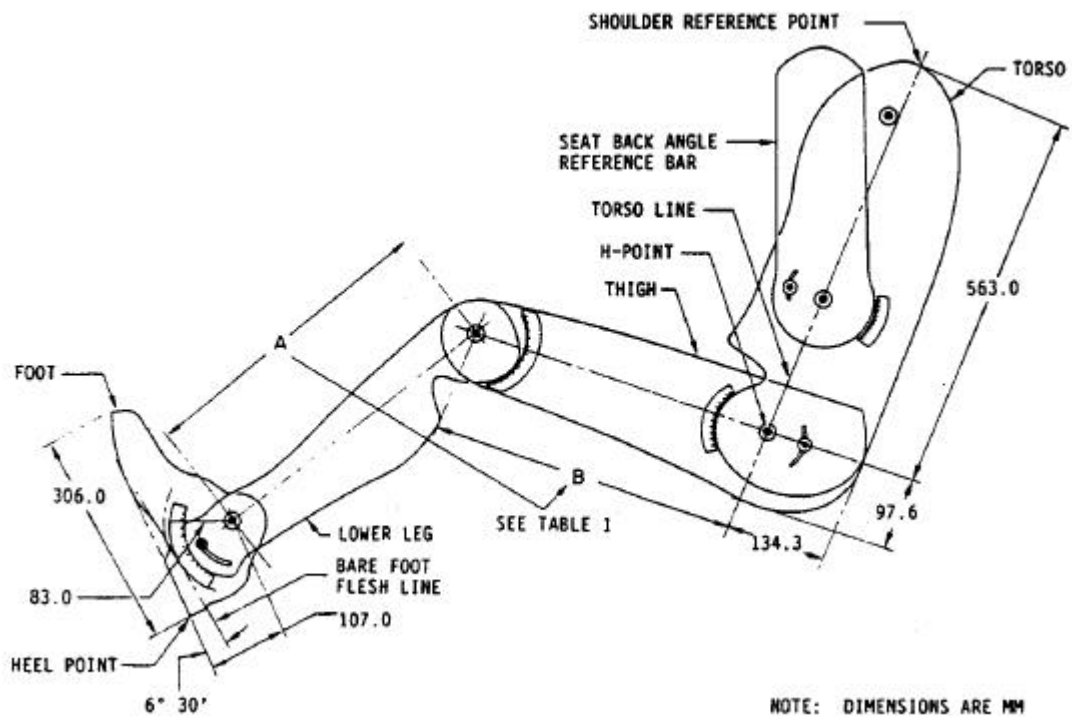
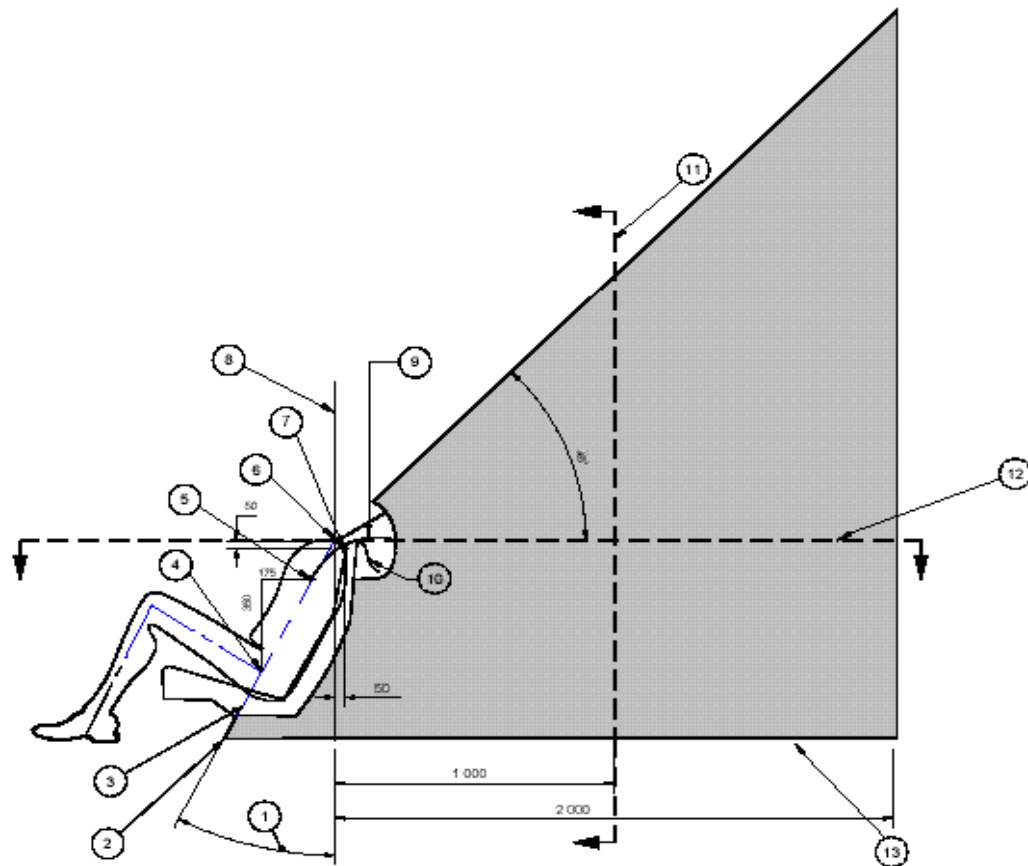

Figure 5: Two dimensions template.

Dimensions in millimetres



**Key**

- 1 Back angle
- 2 Intersection of torso line reference plane and floor pan
- 3 Torso line reference plane
- 4 H-point
- 5 "V" point
- 6 "R" point
- 7 "W" point
- 8 Vertical longitudinal plane
- 9 Strap wrap-around length from "V" point: 250 mm
- 10 Strap wrap-around length from "W" point: 200 mm
- 11 "M" plane cross-section
- 12 "R" plane cross-section
- 13 Line represents the vehicle specific floor pan surface within the prescribed zone

- NOTE 1 Portion of top tether anchorage that is designed to bind with the top tether hook to be located within shaded zone
- NOTE 2 "R" Point: Shoulder reference point
- NOTE 3 "V" Point: V-reference point, 350 mm vertically above and 175 mm horizontally back from H-point
- NOTE 4 "W" Point: W-reference point, 50 mm vertically below and 50 mm horizontally back from "R" point
- NOTE 5 "M" Plane: M-reference plane, 1 000 mm horizontally back from "R" point
- NOTE 6 The forwardmost surfaces of the zone are generated by sweeping the two wraparound lines throughout their extended range in the front part of the zone. The wraparound lines represent the minimum adjusted length of typical top tether straps extending from either the top of the CRS (W-point), or lower on the back of the CRS (V-point).

Figure 6: ISOFIX Top tether anchorage location, ISOFIX zone - Side view

Dimensions in millimetres

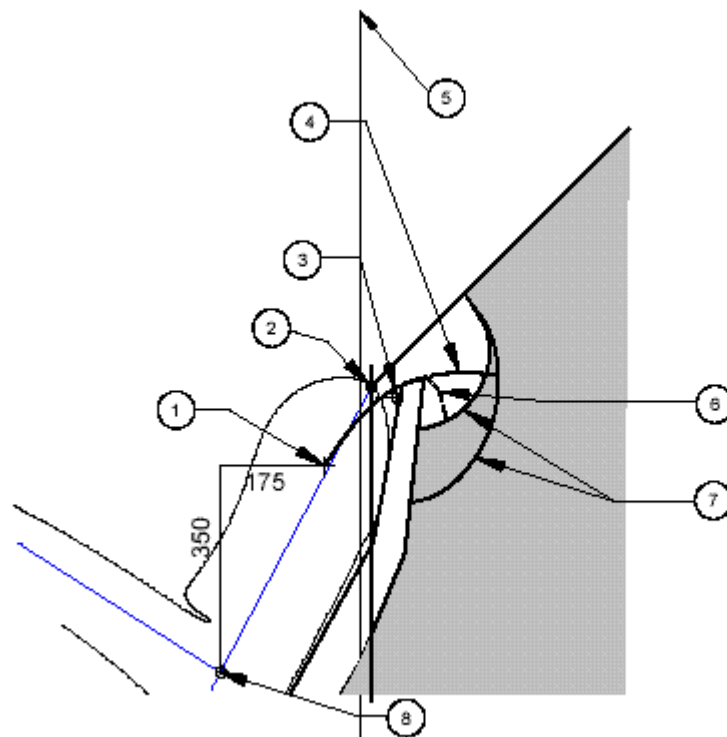

**Key**

- 1 "V" point
- 2 "R" point
- 3 "W" point
- 4 Strap wrap-around length from "V" point: 250 mm
- 5 Vertical longitudinal plane
- 6 Strap wrap-around length from "W" point: 200 mm
- 7 Arcs created by wrap-around lengths
- 8 H-point

NOTE 1 Portion of top tether anchorage that is designed to bind with the top tether hook to be located within shaded zone

NOTE 2 "R" point: Shoulder reference point

NOTE 3 "V" point: V-reference point, 350 mm vertically above and 175 mm horizontally back from H-point

NOTE 4 "W" point: W-reference point, 50 mm vertically below and 50 mm horizontally back from "R" point

NOTE 5 "M" plane: M-reference plane, 1000 mm horizontally back from "R" point

NOTE 6 The forwardmost surfaces of the zone are generated by sweeping the two wraparound lines throughout their extended range in the front part of the zone. The wraparound lines represent the minimum adjusted length of typical top tether straps extending from either the top of the CRS (W-point), or lower on the back of the CRS (V-point).

Figure 7: ISOFIX Top tether anchorage location, ISOFIX zone - Enlarged side view of wrap-around area

Dimensions in millimetres

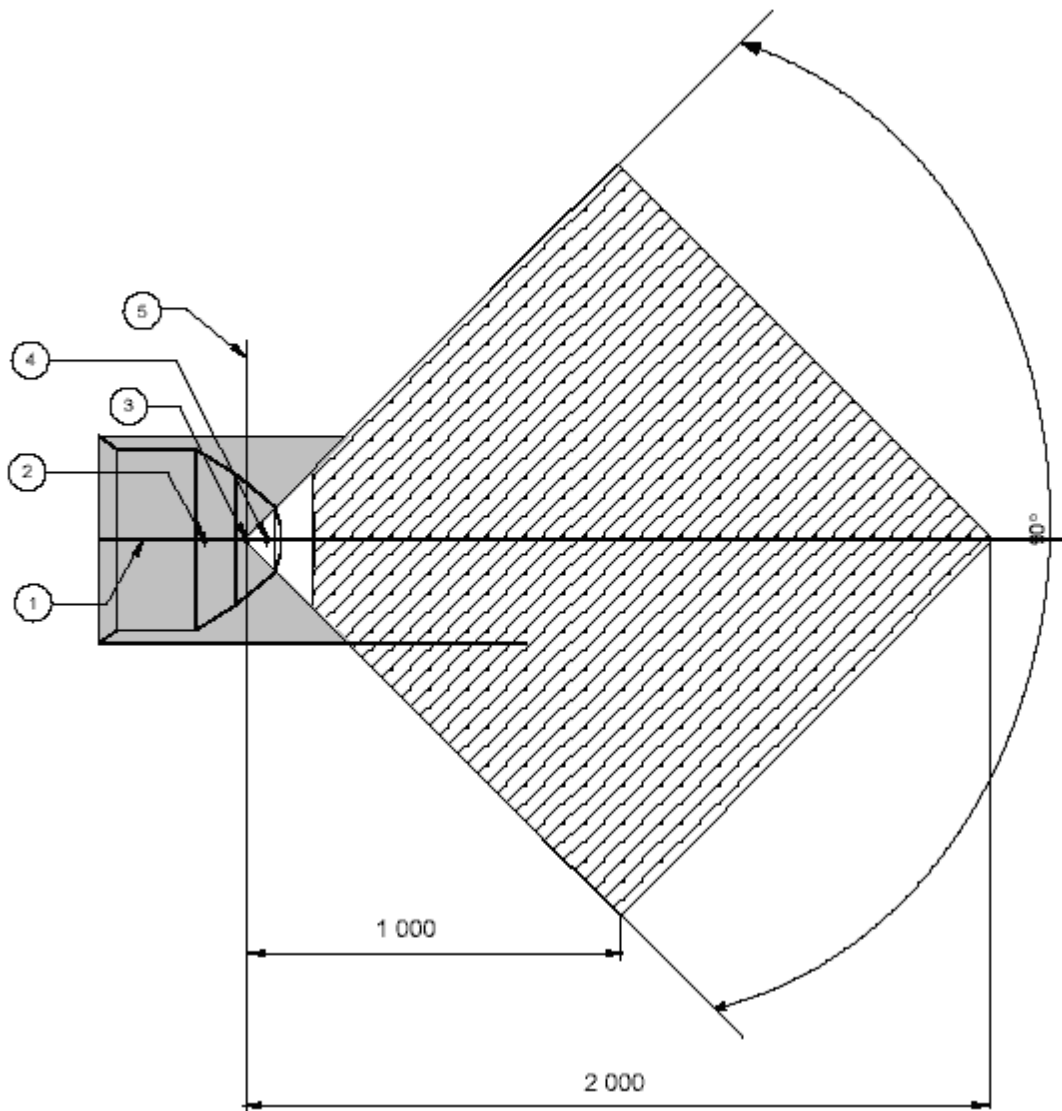

**Key**

- 1 Median plane
- 2 "V" point
- 3 "R" point
- 4 "W" point
- 5 Vertical longitudinal plane

NOTE 1 Portion of top tether anchorage that is designed to bind with the top tether hook to be located within shaded zone

NOTE 2 "R" point: Shoulder reference point

NOTE 3 "V" point: V-reference point, 350 mm vertically above and 175 mm horizontally back from H-point

NOTE 4 "W" point: W-reference point, 50 mm vertically below and 50 mm horizontally back from "R" point

Figure 8: ISOFIX Top tether anchorage location, ISOFIX zone - Plan view  
(R-plane cross section)

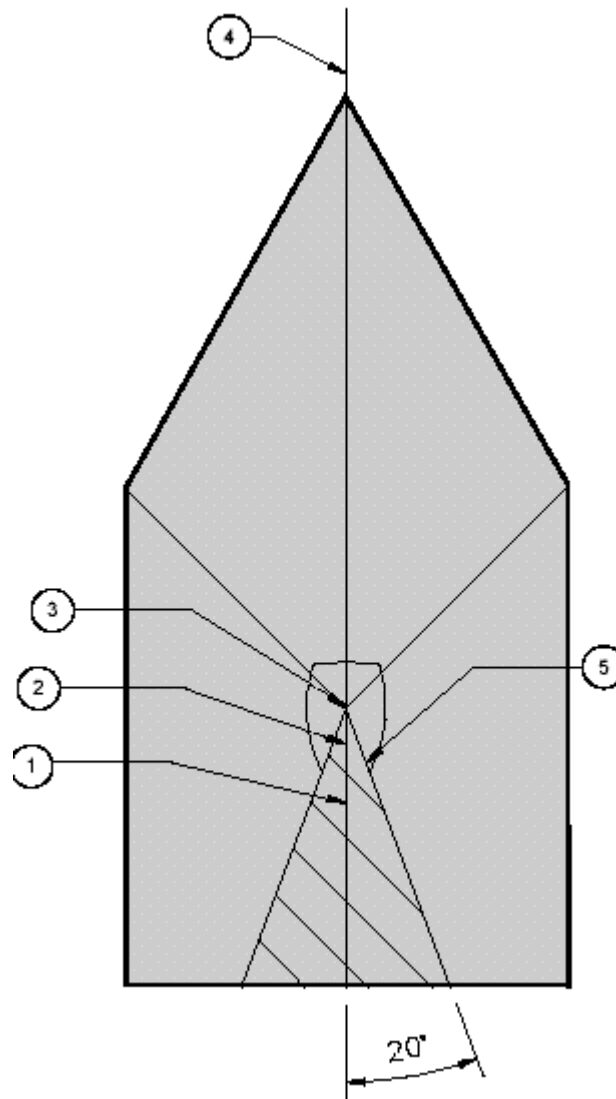

**Key**

- 1 "V" point
- 2 "W" point
- 3 "R" point
- 4 Median plane
- 5 Area view along torso reference plane

NOTE 1 Portion of top tether anchorage that is designed to bind with the top tether hook to be located within shaded zone

NOTE 2 "R" point: Shoulder reference point

NOTE 3 "V" point: V-reference point, 350 mm vertically above and 175 mm horizontally back from H-point

NOTE 4 "W" point: W-reference point, 50 mm vertically below and 50 mm horizontally back from "R" point

Figure 9: ISOFIX Top tether anchorage location, ISOFIX zone - Front view

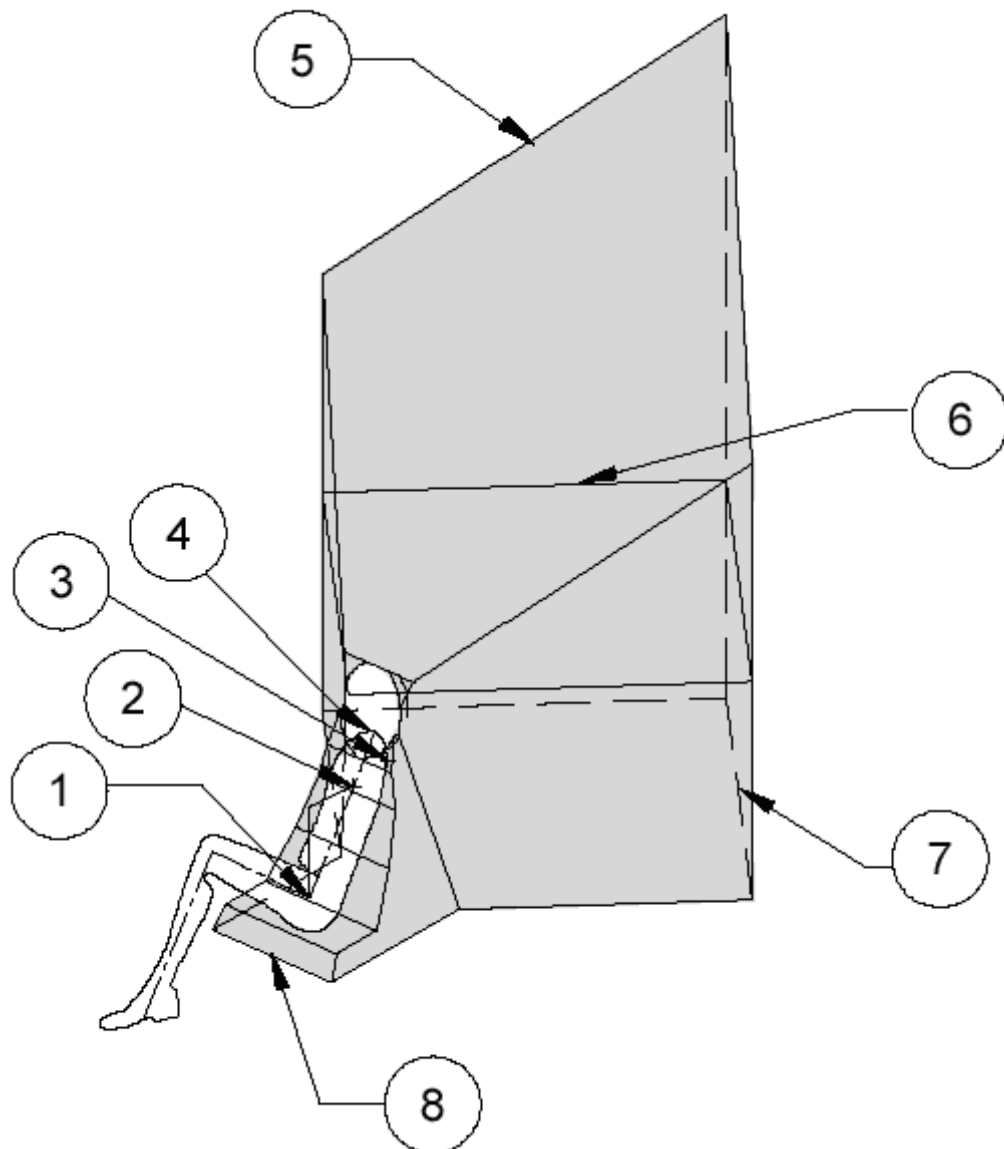

**Key**

- 1 H-point
- 2 "V" point
- 3 "W" point
- 4 "R" point
- 5 45° plane
- 6 "R" plane cross-section
- 7 Floor pan surface
- 8 Front edge of zone

NOTE 1 Portion of top tether anchorage that is designed to bind with the top tether hook to be located within shaded zone

NOTE 2 "R" point: Shoulder reference point

Figure 10: ISOFIX Top tether anchorage location, ISOFIX zone -  
Three-dimensional schematic view

Dimensions in millimetres

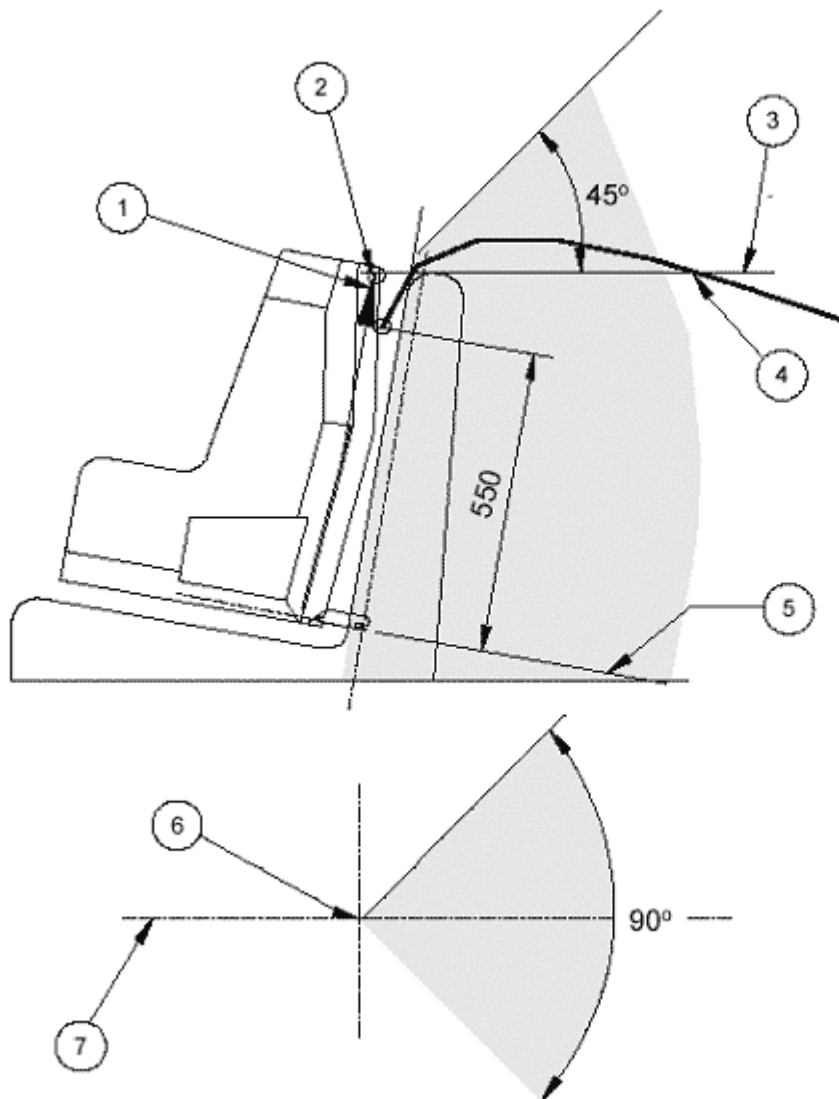

## Key

- 1 CRF vertical reference probe
- 2 Top tether reference line
- 3 Horizontal line
- 4 Top tether wrap around length from fixture: 200 – 2000 mm
- 5 CRF horizontal reference plane
- 6 Tether reference point
- 7 Centreline of CRF

Figure 11: Alternative method of locating the top tether anchorage using the ISOFIX Child Restraint Fixture, ISOFIX zone - Side and plan views





Notes:

1. Drawing not to scale.
2. Symbol may be shown in mirror image.
3. Colour of the symbol at choice of manufacturer.

Figure 12: ISOFIX low anchorage symbol

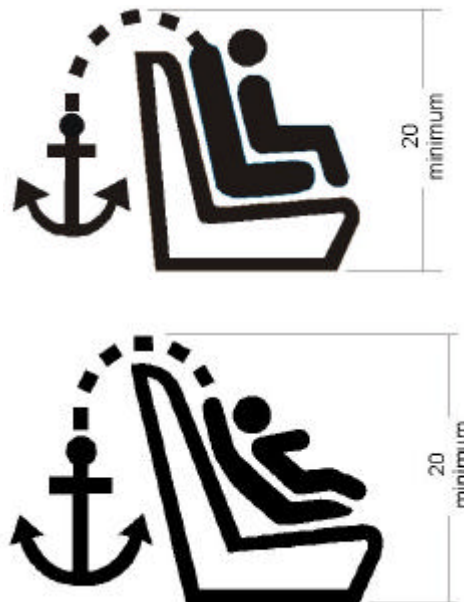

Notes:

1. Dimensions in mm
2. Drawing not to scale
3. The symbol shall be clearly visible either by means of contrast colours or by adequate relief if it is moulded or embossed.

Figure 13: Symbol used to identify the location of a top tether anchorage that is under a cover"

---