

E/ECE/324 }
E/ECE/TRANS/505 } Rev.1/Add.35/Rev.2

2 December 2002

AGREEMENT

**CONCERNING THE ADOPTION OF UNIFORM TECHNICAL PRESCRIPTIONS
FOR WHEELED VEHICLES, EQUIPMENT AND PARTS WHICH CAN BE FITTED
AND/OR BE USED ON WHEELED VEHICLES AND THE CONDITIONS FOR RECIPROCAL
RECOGNITION OF APPROVALS GRANTED ON THE BASIS OF THESE PRESCRIPTIONS */**

(Revision 2, including the amendments which entered into force on 16 October 1995)

Addendum 35: Regulation No. 36

Revision 2

Incorporating all valid text up to:

03 series of amendments - Date of entry into force: 14 December 1992

Corrigendum 1 to Revision 1 of the Regulation, subject of Depository Notification C.N.205.1995.TREATIES-34 dated 4 August 1995

Corrigendum 2 to Revision 1 of the Regulation (Erratum - Russian only)

Supplement 1 to the 03 series of amendments - Date of entry into force: 14 May 1998

Supplement 2 to the 03 series of amendments - Date of entry into force: 6 August 1998

Corrigendum 1 to Supplement 1 to the 03 series of amendments, subject of Depository Notification C.N.270.1999.TREATIES-1 dated 12 April 1999

Corrigendum 3 to Revision 1 of the Regulation (English only), subject of Depository Notification C.N.656.1999.TREATIES-1 dated 20 July 1999

Supplement 3 to the 03 series of amendments - Date of entry into force: 6 July 2000

Supplement 4 to the 03 series of amendments - Date of entry into force: 28 December 2000

Supplement 5 to the 03 series of amendments - Date of entry into force: 21 February 2002

Corrigendum 1 to Supplement 3 to the 03 series of amendments (English and Russian only), subject of Depository Notification C.N.816.2001.TREATIES-2 dated 23 August 2001

Supplement 6 to the 03 series of amendments - Date of entry into force: 20 August 2002 **/

**UNIFORM PROVISIONS CONCERNING THE APPROVAL OF LARGE PASSENGER VEHICLES
WITH REGARD TO THEIR GENERAL CONSTRUCTION**



UNITED NATIONS

*/ Former title of the Agreement:

Agreement Concerning the Adoption of Uniform Conditions of Approval and Reciprocal Recognition of Approval for Motor Vehicle Equipment and Parts, done at Geneva on 20 March 1958.

**/ For Ukraine, the date of entry into force is 20 October 2002.

GE.02-25014

Regulation No. 36

UNIFORM PROVISIONS CONCERNING THE APPROVAL OF LARGE PASSENGER
VEHICLES WITH REGARD TO THEIR GENERAL CONSTRUCTION

CONTENTS

REGULATION	<u>Page</u>
1. Scope	5
2. Definitions	5
3. Application for approval.....	9
4. Approval.....	10
5. Specifications	12
6. Modification and extension of approval of a vehicle type	46
7. Conformity of production.....	47
8. Penalties for non-conformity of production.....	47
9. Production definitely discontinued	47
10. Transitional provisions	47
11. Names and addresses of technical services responsible for conducting approval tests, and of administrative departments.....	48
12. Remarks concerning permissible axle loads or total vehicle mass.....	48

CONTENTS (continued)

ANNEXES

- Annex 1 - Communication concerning the approval or extension or refusal or withdrawal of approval or production definitely discontinued of a vehicle type with regard to its general construction pursuant to Regulation No. 36
- Annex 2 - Arrangements of approval marks
- Annex 3 - Explanatory diagrams
- Annex 4 - Manoeuvrability
- Annex 5 - Testing device for siting of hand-rails and hand-holds
- Annex 6 - Guidelines for measuring the closing forces of power-operated doors

* * *

1. SCOPE

This Regulation applies to single-deck rigid or articulated vehicles designed and constructed for the carriage of persons and having a capacity in excess of 22 passengers, whether seated or standing, in addition to the driver, and having an overall width exceeding 2.30 metres. At the request of the manufacturer, approvals may be granted to vehicles having an overall width of 2.30 metres or less if such vehicles comply with the provisions of this Regulation.

- 1.1. Technical provisions for the carriage of passengers with reduced mobility are outside of the scope of this Regulation. Until harmonized provisions for accessibility are finalized and included in an annex to this Regulation, Contracting Parties may apply additional requirements to ensure access to vehicles and the safety of such passengers.

2. DEFINITIONS

For the purpose of this Regulation:

- 2.1. "Vehicle" means a vehicle designed and equipped for the transport of more than 22 passengers. There are three classes of vehicles:

Class I : city buses
Class II : interurban buses or coaches
Class III : touring coaches

A vehicle may be regarded as belonging in more than one Class. In such a case it may be approved for each Class to which it corresponds;

- 2.1.1. "Class I" Vehicles constructed with areas for standing passengers, to allow frequent passenger movement;
- 2.1.2. "Class II" Vehicles constructed principally for the carriage of seated passengers, and designed to allow the carriage of standing passengers in the gangway and/or in a standing area which does not exceed the space provided for two double seats;
- 2.1.3. "Class III" Vehicles constructed exclusively for the carriage of seated passengers.
- 2.1.4. "Articulated bus or coach" means a vehicle which consists of two or more rigid sections which articulate relative to one another; the passenger compartments of each section intercommunicate so that passengers can move freely between

them; the rigid sections are permanently connected so that they can only be separated by an operation involving facilities which are normally only found in a workshop;

- 2.1.5. "Low floor vehicle" means a vehicle in which at least 35 per cent of the area available for standing passengers (or of its forward section in the case of articulated vehicles) forms a single area without steps, reached through at least one service door by a single step from the ground.
- 2.2. "Vehicle type" means vehicles which do not differ essentially with regard to the constructional features specified in this Regulation;
- 2.3. "Approval of a vehicle" means the approval of a vehicle type with regard to the constructional features specified in this Regulation;
- 2.4. "Service door" means a door used by passengers in normal circumstances with the driver seated;
- 2.5. "Double door" means a door affording two, or the equivalent of two, access passages;
- 2.6. "Emergency door" means a door additional to the service door(s) intended for use by passengers as an exit only exceptionally and, in particular, in an emergency;
- 2.7. "Emergency window" means a window, not necessarily glazed, intended for use as an exit by passengers in an emergency only.
- 2.8. "Double window" means an emergency window which, when divided into two by an imaginary vertical line (or plane), exhibits two parts each of which complies as to dimensions and access with the requirements applicable to a normal emergency window;
- 2.9. "Escape hatch" means an opening in the roof or floor intended for use as an exit by passengers in an emergency only;
- 2.10. "Emergency exit" means an emergency door, emergency window or escape hatch;
- 2.11. "Exit" means a service door or emergency exit;

- 2.12. "Floor or deck" means that part of the bodywork whose upper surface supports standing passengers, the feet of seated passengers and the driver, and the seat mountings;
- 2.13. "Gangway" means the space providing access by passengers from any seat or row of seats to any other seat or row of seats or to any access passage from or to any service door; it does not include:
- 2.13.1. the space extending 30 cm in front of any seat.
- 2.13.2. the space above the surface of any step or staircase, or
- 2.13.3. any space which affords access solely to one seat or one row of seats;
- 2.14. "Access passage" means the space extending inwards into the vehicle from the service door up to the outermost edge of the upper step (edge of the gangway). Where there is no step at the door, the space to be considered as access passage shall be that which is measured according to paragraph 5.7.1.1. up to a distance of 30 cm from the starting position of the inner face of the dual panel.
- 2.15. "Driver's compartment" means the space intended for the driver's exclusive use and containing the driver's seat, the steering wheel, controls, instruments and other devices necessary for driving the vehicle.
- 2.16. "Unladen kerb mass" (MK) (kg) means the mass of the vehicle in running order, unoccupied and unladen but with the addition of 75 kg for the mass of the driver, the mass of fuel corresponding to 90 per cent of the capacity of the fuel tank specified by the manufacturer, and the masses of coolant, lubricant, tools and spare wheel, if any;
- 2.16.1. "Unladen mass" (MV) (kg) means the unladen kerb mass (MK) (kg) of the vehicle as defined in paragraph 2.16., with the addition of 75 kg for the mass of the crew member corresponding to the seat, if any, specially assigned to this crew member as described in paragraph 5.7.1.8. The vehicle shall be complete with 90 per cent of the capacity of all additional liquid tanks (e.g. fuel for combustion heaters, screen washers, etc.). Where facilities such as a kitchen or toilet are fitted, the fresh water tanks shall be full and the waste tanks empty.
- 2.17. "Technically permissible maximum mass" means the maximum mass declared by the manufacturer of the vehicle. (This mass may be greater than the "permissible maximum mass" to be prescribed by national administrations).

- 2.18. "Technically permissible maximum axle mass" means that part of the technically permissible maximum mass of the vehicle, declared by the manufacturer, which results in the vertical force at the road surface in the contact area on the wheel/wheels of an axle. This mass may be greater than the maximum permissible axle mass authorized by national administrations. The sum of all technically permissible maximum axle masses of the vehicle may be greater than the technically permissible maximum mass of that vehicle.
- 2.19. "Passenger" means a person other than the driver or a member of the crew;
- 2.19.1. "Passenger with reduced mobility" means all passengers who have a special difficulty when using public transport, especially elderly and disabled people. Reduced mobility does not necessarily imply any form of medical impairment.
- 2.20. "Passenger compartment" means the space intended for passengers' use excluding any space occupied by fixed appliances such as bars, kitchenettes or toilets;
- 2.21. "Automatically operated service door" means a power-operated service door which can be opened (other than by means of emergency controls) only after a control is operated by a passenger, and after activation of the controls by the driver, and which closes again automatically;
- 2.22. "Starting prevention device" means a device which prevents the vehicle being driven away from rest when a door is not fully closed;
- 2.23. "Driver operated service door" means a service door which normally is opened and closed by the driver.
- 2.24. Unless otherwise stated, all measurements shall be made when the vehicle is at its unladen kerb mass (MK) (kg) and it is standing on a smooth and horizontal ground surface. If a kneeling system is fitted to the vehicle, it shall not be in operation.
- 2.25. Wherever there is a requirement in this Regulation for a surface in the vehicle to be horizontal or at a specific angle when the vehicle is at its unladen kerb mass (MK) (kg), in the case of a vehicle with mechanical suspension, the surface may exceed this slope or possess a slope when the vehicle is at its unladen kerb mass (MK) (kg), provided that this requirement is met when the vehicle is in the loading condition declared by the manufacturer. If a kneeling system is fitted to the vehicle, it shall not be in operation.

3. APPLICATION FOR APPROVAL

- 3.1. The application for approval of a vehicle type with regard to its constructional features shall be submitted by the vehicle manufacturer or by his duly accredited representative.
- 3.2. It shall be accompanied by the undermentioned documents in triplicate and by the following particulars:
- 3.2.1. a detailed description of the vehicle type with respect to its structure, dimensions, configuration and constituent materials;
- 3.2.2. drawings of the vehicle and its interior arrangement; and
- 3.2.3. particulars of
- 3.2.3.1. the technical maximum mass (PT) (kg). "In the case of an articulated bus or coach, it shall be given separately for each rigid portion;"
- 3.2.3.2. the technical maximum mass for each axle (kg);
- 3.2.3.3. the unladen mass of the vehicle (MV) (kg);
- 3.2.4. provision made, if any for the carriage of baggage or goods;
- 3.2.5. where one or more baggage compartments have been provided for baggage other than hand baggage, the total volume of such compartments (V) (m^3) and the total mass of the baggage that they can obtain (B) (kg);
- 3.2.6. where the vehicle is equipped to carry baggage on the roof, the total surface area available for such baggage (VX) (m^2) and the total mass of baggage that can be placed on it (BX) (kg);
- 3.2.7. the horizontal projection of the total surface area intended for seated and standing passengers (S_0) (m^2);
- 3.2.8. the horizontal projection of the total surface area intended for standing passengers (S_1) (m^2) in accordance with paragraph 5.2;
- 3.2.9. the number of seating places intended for use by passengers and crew (if any). Sleeping places and other accommodations which are intended to be temporarily used instead of a seating place shall not count as seating places.

- 3.2.10. the intended total number of passengers (N);
- 3.2.11. the class or classes for which approval is requested.
- 3.3. A vehicle representative of the type to be approved shall be submitted to the technical service responsible for conducting the approval tests.
4. APPROVAL
- 4.1. If the vehicle submitted for approval pursuant to this Regulation meets the requirements of paragraph 5. below, approval of that vehicle type shall be granted.
- 4.2. An approval number shall be assigned to each vehicle type approved. Its first two digits (at present 03, corresponding to the 03 series of amendments which entered into force on 14 December 1992) shall indicate the series of amendments incorporating the most recent major technical amendment made to the Regulation at the time of issue of the approval. The same Contracting Party may not assign the same number to another vehicle type within the meaning of paragraph 2.2. above.
- 4.3. Notice of approval or of extension or refusal or withdrawal of approval or production definitely discontinued of a vehicle type pursuant to this Regulation shall be communicated to the Parties to the Agreement which apply this Regulation by means of a form conforming to the model in annex 1 to this Regulation.
- 4.4. There shall be affixed, conspicuously and in a readily accessible place specified on the approval form, to every vehicle conforming to a vehicle type approved under this Regulation, an international approval mark consisting of:

- 4.4.1. a circle surrounding the letter "E" followed by the distinguishing number of the country which has granted approval 1/₁; and
- 4.4.2. the number of this Regulation, followed by the letter "R", a dash and the approval number, to the right of the circle prescribed in paragraph 4.4.1; and
- 4.4.3. an additional symbol separated from the number of this Regulation by a vertical line and consisting of the Roman numeral(s) for the Class(es) in which the vehicle has been approved.
- 4.5. If the vehicle conforms to a vehicle type approved, under one or more other Regulations annexed to the Agreement, in the country which has granted approval under this Regulation, the symbol prescribed in paragraph 4.4.1. need not be repeated; in such a case, the regulation and approval numbers and the additional symbols of all the Regulations under which approval has been granted in the country which has granted approval under this Regulation shall be placed in vertical columns to the right of the symbol prescribed in paragraph 4.4.1.
- 4.6. The approval mark shall be clearly legible and be indelible.
- 4.7. The approval mark shall be placed close to or on the vehicle data plate affixed by the manufacturer.
- 4.8. Annex 2 to this Regulation gives examples of arrangements of approval marks.

1/₁ 1 for Germany, 2 for France, 3 for Italy, 4 for the Netherlands, 5 for Sweden, 6 for Belgium, 7 for Hungary, 8 for the Czech Republic, 9 for Spain, 10 for Yugoslavia, 11 for the United Kingdom, 12 for Austria, 13 for Luxembourg, 14 for Switzerland, 15 (vacant), 16 for Norway, 17 for Finland, 18 for Denmark, 19 for Romania, 20 for Poland, 21 for Portugal, 22 for the Russian Federation, 23 for Greece, 24 for Ireland, 25 for Croatia, 26 for Slovenia, 27 for Slovakia, 28 for Belarus, 29 for Estonia, 30 (vacant), 31 for Bosnia and Herzegovina, 32 for Latvia, 33 (vacant), 34 for Bulgaria, 35 (vacant), 36 for Lithuania, 37 for Turkey, 38 (vacant), 39 for Azerbaijan, 40 for The former Yugoslav Republic of Macedonia, 41 (vacant), 42 for the European Community (Approvals are granted by its Member States using their respective ECE symbol), 43 for Japan, 44 (vacant), 45 for Australia, 46 for Ukraine, 47 for South Africa and 48 for New Zealand. Subsequent numbers shall be assigned to other countries in the chronological order in which they ratify or accede to the Agreement Concerning the Adoption of Uniform Technical Prescriptions for Wheeled Vehicles, Equipment and Parts which can be Fitted and/or be Used on Wheeled Vehicles and the Conditions for Reciprocal Recognition of Approvals Granted on the Basis of these Prescriptions, and the numbers thus assigned shall be communicated by the Secretary-General of the United Nations to the Contracting Parties to the Agreement.

5. SPECIFICATIONS

5.1. Load distribution between axles and loading conditions

5.1.1. The load distribution of a stationary vehicle on level ground shall be determined in two conditions:

5.1.1.1. unladen, as specified in paragraph 5.1.3., and

5.1.1.2. laden, as specified in paragraph 5.1.4.

5.1.2. The front axle or axles shall carry not less than the percentage of mass shown in the table below:

Loading conditions	Class I		Class II		Class III	
	Rigid	Articulated	Rigid	Articulated	Rigid	Articulated
Unladen	20	20	25	20	25	20
Laden	25	20	25	20	25	20

5.1.3. Unladen, for the purpose of this paragraph (5.1.), and paragraph 5.3., means the vehicle in the condition described in paragraph 2.16.1.

5.1.4. Laden, for the purpose of this paragraph (5.1.), means the vehicle unladen as described in paragraph 5.1.3. with the addition of a mass Q on each passenger seat, a number, corresponding to the authorised number of standing passengers, of masses Q uniformly distributed over the area S_1 , a mass equal to B uniformly distributed in the baggage compartments and, where appropriate, a mass equal to BX uniformly distributed over the surface area of the roof equipped for the carriage of baggage.

5.1.5. The values of Q for the different Classes of vehicle are specified in paragraph 5.3. below.

5.1.6. B (kg) shall have a numerical value not less than $100 V (m^3)$.

5.1.7. BX shall exert a specific load of not less than 75 kg/m^2 over the whole surface area of the roof equipped for the carriage of baggage.

5.2. Area available for passengers

- 5.2.1. The total surface area S_0 available for passengers is calculated by deducting from the total area of the vehicle:
- 5.2.1.1. the area of the driver's compartment;
 - 5.2.1.2. the area of steps at doors and the area of any step with a depth of less than 30 cm;
 - 5.2.1.3. the area of any part over which the vertical clearance is less than 135 cm measured from the floor (disregarding intrusions permitted according to paragraph 5.7.8.6.2.); and
 - 5.2.1.4. the area of any part of the articulated section(s) of an articulated bus or coach to which part access is prevented by handrails and/or partitions.
- 5.2.2. The surface area S_1 available for standing passengers (only in the case of vehicles of Class I and Class II, in which the carriage of standing passengers is allowed) is calculated by deducting from S_0 :
- 5.2.2.1. in vehicles of Class I and Class II:
 - 5.2.2.1.1. the area of all parts of the floor in which the slope exceeds 8 per cent;
 - 5.2.2.1.2. the area of all parts which are not accessible to a standing passenger when all the seats are occupied, with the exception of folding seats;
 - 5.2.2.1.3. the area of all parts where the clear height above the floor is less than 190 cm or - in the case of the section of the gangway situated above and behind the rear axle, and the attaching parts thereof - less than 180 cm (hand-holds shall not be taken into account in this connection);
 - 5.2.2.1.4. the area forward of a vertical plane passing through the centre of the seating surface of the driver's seat (in its rearmost position) and through the centre of the exterior rear-view mirror mounted on the opposite side of the vehicle; and,
 - 5.2.2.1.5. the area 30 cm in front of all seats other than folding seats;
 - 5.2.2.1.6. any surface not being excluded by the provisions in paragraphs 5.2.2.1.1. to 5.2.2.1.5. above, on which it is not possible to place a rectangle of 400 mm x 300 mm;

5.2.2.1.7. in vehicles of Class II, the area in which standing is not allowed.

5.3. Passenger capacity

5.3.1. There shall be on the vehicle a number (P_s) of seating places (see para. 3.2.9. above), other than folding seats, which conform to the requirements of paragraph 5.7.8. If the vehicle is of Class I or Class II, the number P_s shall be at least equal to the number of square metres of floor available for passengers and crew (if any) (S_o) rounded down to the nearest whole number; the required number may be reduced by 10 per cent in the case of Class I vehicles ($0.9 S_o$).

5.3.2. The total number N of seating and standing places in vehicles shall be calculated such that both of the following conditions are fulfilled:

$$N \leq P_s + \frac{S_1}{S_{sp}}$$

and

$$N \leq \frac{MT - MV - L \cdot V - R \cdot VX}{Q}$$

where:

P_s = Number of seating places (see paragraphs 3.2.9. and 5.3.1.);

S_1 = Surface area (m^2) (see paragraph 5.2.2.) available for standing passengers;

S_{sp} = Area assumed for one standing passenger (m^2 /standing passenger) (see paragraph 5.3.2.2.);

MT = Technically permissible maximum mass (kg) (see paragraph 2.17.);

MV = Unladen mass (kg) as defined in paragraph 2.16.1.;

L = Specific load of baggage (kg/m^3) in the baggage compartment(s);

V = Total volume (m^3) of the baggage compartments (see paragraph 3.2.5.);

R = Specific mass of baggage in the roof area (kg/m^2);

VX = Total surface area (m²) available for baggage to be carried on the roof (see paragraph 3.2.6.);

Q = Mass (kg) assumed for the load on each passenger seating and standing place, if any (see paragraph 5.3.2.2.).

5.3.2.1. In the case of Class III vehicles, S₁ = 0.

5.3.2.2. The values of Q, S_{sp}, L and R for every class of vehicle are as follows:

Class	Q (kg)	S _{sp} (m ² /standing passenger)	L (kg/m ³)	R (kg/m ²)
I	68	0.125	100	75
II	71 <u>*/</u>	0.150	100	75
III	71 <u>*/</u>	(no standing passengers)	100	75

*/ Including 3 kg of hand baggage.

5.3.2.3. If a vehicle of Class II or Class III is approved as a Class I vehicle, the mass of baggage carried in the baggage compartments accessible only from outside the vehicle is not taken into account.

5.3.3. When calculated according to paragraph 5.3.2., the mass on each axle of the vehicle shall not exceed the values of their respective technically permissible maximum values.

5.3.4. The vehicle shall be clearly marked in a manner visible on the inside in the vicinity of the front door in letters or pictograms not less than 15 mm high and numbers not less than 25 mm high, with

5.3.4.1. the number of seating places for which the vehicle is designed (P_s);

5.3.4.2. the total number of passengers for which the vehicle is designed (N);

5.4. (Not allocated)

5.5. Protection against fire risks

5.5.1. Engine compartment

- 5.5.1.1. No flammable sound-proofing material or material liable to become impregnated with fuel or lubricant shall be used in the engine compartment unless the material is covered by an impermeable sheet.
- 5.5.1.2. Precautions shall be taken, either by a suitable layout of the engine compartment or by the provision of drainage orifices, to avoid, so far as possible, the accumulation of fuel or lubricating oil in any part of the engine compartment.
- 5.5.1.3. A partition of heat-resisting material shall be fitted between the engine compartment or any other source of heat (such as a device designed to absorb the energy liberated when a vehicle is descending a long gradient, e.g. a retarder or a device for heating the interior of the body other, however, than a device functioning by warm water circulation) and the rest of the vehicle.
- 5.5.2. Fuel filler-holes
- 5.5.2.1. Fuel filler-holes shall be accessible only from outside the vehicle.
- 5.5.2.2. No part of fuel filler-holes shall be less than 50 cm from any service door or emergency door aperture when the fuel tank is intended to contain petrol, and not less than 25 cm when it is intended to contain diesel fuel; they shall moreover not be in the passenger compartment, nor in the driver's compartment. Fuel-filler-holes shall not be so located that there is a risk of fuel falling on to the engine or exhaust system during filling.
- 5.5.2.3. The fuel shall not be able to run out through the filler-hole cap or through the devices provided to stabilize the pressure in the tank, even if the tank is completely overturned; a slight drip shall however be tolerated if it does not exceed 30 g/min. If the vehicle is fitted with several interconnected fuel tanks, the pressure during the test shall correspond to the most unfavourable position for the fuel tanks.
- 5.5.2.4. If the filler-hole is situated on a side of the vehicle, the cap shall, when closed, not project beyond the adjacent surfaces of the bodywork.
- 5.5.2.5. Fuel filler-hole caps shall be so designed and constructed that they cannot be opened accidentally.
- 5.5.3. Fuel tanks
- 5.5.3.1. Every fuel tank shall be securely fixed. No part of a fuel tank shall be less than 60 cm from the front of the vehicle or less than 30 cm from the rear of the vehicle so as to provide protection in the event of front or rear impact.

- 5.5.3.2. No part of a fuel tank shall project beyond the overall width of the bodywork.
- 5.5.3.3. All tanks shall be subjected to a hydraulic internal-pressure test, which shall be carried out on an isolated unit complete with standard filler-pipe, filler-neck and cap.
The tank shall be completely filled with water. After all communication with the outside has been cut off, the pressure shall be gradually increased, through the pipe connection through which fuel is fed to the engine, to a relative pressure which is double the service pressure, but not less than 0.3 bar, which shall be maintained for one minute. During this time the tank shell shall not crack or leak; it may, however, be permanently distorted.
- 5.5.3.4. Fuel tanks must be made so as to be corrosion resistant.
- 5.5.3.5. Any excess pressure or any pressure exceeding the working pressure must be automatically compensated by suitable devices (vents, safety valves, etc.). The vents must be designed in such a way as to prevent any fire risks.
- 5.5.4. Fuel-feed systems
- 5.5.4.1. No apparatus used for the fuel feed shall be placed in the driver's compartment or the passenger compartment.
- 5.5.4.2. Fuel lines and all other parts of the fuel-feed system shall be accommodated in positions on the vehicle where they have the fullest reasonable protection.
- 5.5.4.3. Twisting or bending movements and vibration of the vehicle structure or the power unit shall not subject the fuel lines to abnormal stress.
- 5.5.4.4. The unions of pliable or flexible pipes with rigid parts of the fuel-feed system shall be so designed and constructed as to remain leakproof in the various conditions of use of the vehicle, despite aging, twisting or bending movements, or vibration of the vehicle structure or the power unit.
- 5.5.4.5. Fuel leaking from any part of the system shall be able to flow away freely to the road surface, but never onto the exhaust system.
- 5.5.5. Emergency switch
- There shall be provided an emergency switch which is intended to reduce the risk of fire after the vehicle has come to a standstill. This emergency switch shall have the following characteristics:

- 5.5.5.1. It shall be located within immediate reach of the driver seated in the driver's seat.
- 5.5.5.2. It shall be clearly marked and be provided with a protective cover or other suitable means to prevent inadvertent operation. Clear instructions concerning the method of operation shall be displayed in the immediate vicinity of the emergency switch, e.g. "Remove cover and move lever downwards! Actuate only when the vehicle has been brought to a stop".
- 5.5.5.3. Its actuation shall cause simultaneous performance of the following functions:
- 5.5.5.3.1. quick stoppage of the engine;
- 5.5.5.3.2. operation of a battery isolating switch, fitted as close to the batteries as possible, and which isolates at least one battery terminal from the electrical circuit, with the exception of the circuit performing the function required by paragraph 5.5.5.3.3. below, the circuits which ensure the uninterrupted function of the tachograph as well as those devices whose sudden removal from service could provoke a greater risk than the one avoided, for example:
- 5.5.5.3.2.1. emergency interior lighting;
- 5.5.5.3.2.2. cooling scavenger of auxiliary heaters;
- 5.5.5.3.2.3. centralized electronic door locking;
- 5.5.5.3.3. switching-on of the vehicle's hazard warning signal;
- 5.5.5.4. Performance of the functions mentioned in paragraph 5.5.5.3. above may be initiated not only by the emergency switch, but also by separate controls, provided that these do not in an emergency interfere with the functioning of the emergency switch.
- 5.5.6. Electrical equipment and wiring
- 5.5.6.1. All cables shall be well insulated and all cables and electrical equipment shall be able to withstand the temperature and humidity conditions to which they are exposed. In the engine compartment, particular attention shall be paid to their suitability to withstand the environmental temperature, oil and vapour.

- 5.5.6.2. No cable used in an electrical circuit shall carry a current in excess of that acceptable for such a cable in the light of its mode of installation and the maximum ambient temperature.
- 5.5.6.3. Every electrical circuit feeding an item of equipment other than the starter, the ignition circuit (positive ignition), the glow-plugs, the engine-stopping device, the battery-charging circuit and the battery shall include a fuse or a circuit breaker. Circuits feeding low consumption equipment may, however, be protected by a common fuse or a common circuit-breaker, provided that its rated capacity does not exceed 16 A.
- 5.5.6.4. All cables shall be well protected and shall be held securely in position in such a way that they cannot be damaged by cutting, abrasion or chafing.
- 5.5.6.5. Where the voltage exceeds 100 Volts RMS (root mean square) in one or more electrical circuits in a vehicle, a manually-operated isolating switch which is capable of disconnecting all such circuits from the main electrical supply shall be connected in each pole of that supply which is not electrically connected to earth, and shall be located inside the vehicle in a position readily accessible to the driver, provided that no such isolating switch shall be capable of disconnecting any electrical circuit supplying the mandatory external vehicle lights.
- 5.5.6.6. There shall be at least two internal lighting circuits such that failure of one will not affect the other. A circuit serving only permanent entry and exit lighting can be considered as one of these circuits.
- 5.5.7. Batteries
- 5.5.7.1. All batteries shall be well secured and easily accessible.
- 5.5.7.2. The battery compartment shall be separated from the passenger compartment and driver's compartment and ventilated to outside air.
- 5.5.8. Fire extinguishers and first-aid equipment
- 5.5.8.1. Space shall be provided for the fitting of one or more fire extinguishers, one being near the driver's seat and the space provided for each measuring not less than 600 mm x 200 mm x 200 mm. Local intrusions into this space are permitted provided a fire extinguisher of adequate size may still be fitted.

5.5.8.2. Space shall be provided for the fitting of one or more first-aid kits. The space provided shall be not less than 7 dm³, the minimum dimension shall not be less than 80 mm.

5.5.9. Materials

No flammable material shall be permitted within 10 cm of the exhaust pipe unless the material is effectively shielded.

5.6. Exits

5.6.1. Number

5.6.1.1. The minimum number of service doors required is as follows:

Number of passengers	Number of service doors		
	Class I	Class II	Class III
23 - 45	1	1	1
46 - 70	2	1	1
71 - 100	3	2	1
> 100	4	3	1

5.6.1.2. The minimum number of service doors in each rigid section of an articulated bus or coach shall be one except that this minimum number shall be two in the case of the front section of an articulated bus of Class I.

5.6.1.3. The minimum number of doors in a vehicle shall be two.

5.6.1.4. For the purpose of this requirement, service doors equipped with a power operated control system shall not be deemed to be exits unless they can be readily opened by hand, once the control prescribed in paragraph 5.6.5.1. has been actuated if necessary.

5.6.1.5. The minimum number of emergency exits shall be such that the total number of exits is as follows:

Number of passengers	Minimum total number of exits
23 - 30	4
31 - 45	5
46 - 60	6
61 - 75	7
76 - 90	8
> 90	9

Escape hatches can only count as one of the above-mentioned number of emergency exits.

- 5.6.1.6. Each rigid section of an articulated vehicle shall be treated as a separate vehicle for the purpose of determining the minimum number of exits. A number of passengers shall be determined for each rigid section and the connecting passage between them shall not be considered as an exit.
- 5.6.1.7. If the driver's or a separate crew compartment does not communicate with the inside of the vehicle it shall have two exits, which shall not both be in the same lateral walls; where one of the exits is a window it shall comply with the requirements set out in paragraph 5.6.8. for emergency windows.
- 5.6.1.8. A double service door shall count as two doors and a double window as two emergency windows.
- 5.6.1.9. Escape hatches, additional to the emergency doors and windows, shall be fitted in Class II and Class III vehicles. They may also be fitted in the case of Class I vehicles. The minimum number of hatches shall be:

Number of passengers	Number of hatches
not exceeding 50	1
exceeding 50	2

5.6.2. Siting of exits

- 5.6.2.1. The service doors shall be situated on the side of the vehicle that is nearer to the side of the road corresponding to the direction of traffic in the country in which

the vehicle is licensed for operation, and at least one of them shall be in the forward half of the vehicle.

5.6.2.2. Two of the doors shall be separated such that the distance between transverse vertical planes through their centres of area is not less than 40 per cent of the overall length of the passenger compartment measured parallel to the longitudinal axis of the vehicle.

In the case of an articulated vehicle, this requirement shall be fulfilled if two doors of the different sections are separated such, that the distance between the doors is not less than 40 per cent of the overall length of the combined passenger compartment (all sections). In either case, if one of these doors forms part of a double door this distance shall be measured between the doors which are furthest apart.

5.6.2.3. The exits shall be placed in such a way that their number on each of the two sides of the vehicle is substantially the same.

5.6.2.4. At least one emergency exit shall be situated either in the rear face or in the front face of the vehicle respectively. For Class I vehicles and for vehicles with a rear part permanently closed off from the passengers' compartment, this provision is fulfilled if an escape hatch is fitted.

5.6.2.5. The exits on the same side of the vehicle shall be suitably spaced out along the length of the vehicle.

5.6.2.6. A door shall, provided that it is not a service door, be permitted in the rear face of the vehicle.

5.6.2.7. If escape hatches are fitted, they shall be positioned as follows: If there is only one hatch, it shall be situated in the middle third of the vehicle; if there are two hatches, they shall be separated by a distance of at least 2m measured between the nearest edges of the apertures in a line parallel with the longitudinal axis of the vehicle.

5.6.3. Minimum dimensions

5.6.3.1. The several kinds of exits shall have the following minimum dimensions of free access:

		Class I	Class II	Class III	Remarks
Service door	Door aperture	Height (cm)	180	165	---
		Width (cm)	Single door : 65 Double door : 120		This dimension may be reduced by 10 cm when the measurement is made at the level of the hand-holds. The required width of free access shall be ensured in the height of 70 to 160 cm related to the level of the first step (see annex 3, figure 12)
Emergency door		Height (cm)	125		---
		Width (cm)	55		
Emergency window	Area (cm ²)	4,000		It shall be possible to inscribe in this area a rectangle 50 cm high and 70 cm wide.	
Emergency window situated in the rear face of the vehicle, if the manufacturer does not provide an emergency window of the minimum dimensions prescribed above.		It shall be possible to inscribe in the emergency window aperture a rectangle 35 cm high and 155 cm wide. The corners of the rectangle may be rounded to a radius of curvature not exceeding 25 cm.			
Escape hatch	Aperture area (cm ²)	4,000		It shall be possible to inscribe in this area a rectangle measuring 50 x 70 cm	

5.6.4. Technical requirements for all service doors

5.6.4.1. Every service door shall be capable of being easily opened from inside and from outside the vehicle when the vehicle is stationary (but not necessarily when the vehicle is moving). However, this requirement shall not be construed as precluding the possibility of locking the door from the outside, provided that the door can always be opened from the inside.

5.6.4.2. Every control or device for opening a service door from outside shall not be more than 180 cm from the ground when the vehicle is standing unladen on a level surface.

- 5.6.4.3. Every one-piece manually-operated service door which is hinged or pivoted shall be so hinged or pivoted that, if the open door comes into contact with a stationary object while the vehicle is moving forwards, it tends to close.
- 5.6.4.4. If a manually-operated service door is fitted with a slam lock it shall be of the two-stage type.
- 5.6.4.5. On the inside of a service door there shall not be any device intended to cover the inside steps when the door is closed.
- 5.6.4.6. If the direct view is not adequate, optical or other devices shall be installed to enable the driver to detect from his seat the presence of a passenger in the immediate interior and exterior vicinity of every service door which is not an automatically-operated service door.
- 5.6.4.7. Every service door which opens towards the interior of the vehicle shall be so constructed that its movement is not likely to cause injury to passengers in normal conditions of use. Where necessary, appropriate protection devices shall be fitted.
- 5.6.4.8. If a service door is located adjacent to a door to a toilet or other internal compartment the service door shall be proofed against unintentional operation. However, this requirement shall not apply if the door is locked automatically when the vehicle is moving at a speed exceeding 5 km/h.
- 5.6.4.9. The service door in any open position shall not obstruct the use of, or required access to any mandatory exit.
- 5.6.5. Additional technical requirements for power-operated service doors
- 5.6.5.1. In the event of an emergency every power-operated service door shall be capable, when the vehicle is stationary (but not necessarily when the vehicle is moving), of being opened from inside and, when not locked, from outside by controls which, whether or not the power supply is operating:
- 5.6.5.1.1. override all other controls;
- 5.6.5.1.2. in the case of interior controls, are placed on, or within 300 mm of, the door, at a height of not less than 1,600 mm above the first step;
- 5.6.5.1.3. can be easily seen and clearly identified when approaching the door and when standing in front of the door;

- 5.6.5.1.4. can be operated by one person when standing immediately in front of the door;
- 5.6.5.1.5. cause the door to open, or enable the door to be easily opened by hand;
- 5.6.5.1.6. may be protected by a device which can be easily removed or broken to gain access to the emergency control; the operation of the emergency control, or the removal of a protective cover over the control, shall be indicated to the driver both audibly and visually, and
- 5.6.5.1.7. in the case of a driver-operated door which does not comply with the requirements of paragraph 5.6.5.6.2. below, the controls shall be such that after they have been operated to open the door and returned to their normal position, the door will not close again until the driver subsequently operates a closing control.
- 5.6.5.2. A device may be provided which is operated by the driver from his seat to deactivate the outside emergency controls in order to lock the service doors from outside. In this case, the outside emergency controls shall be reactivated automatically either by the starting of the engine or before the vehicle reaches a speed of 20 km/h. Subsequently, deactivation of the outside emergency controls shall not occur automatically, but shall require a further action by the driver.
- 5.6.5.3. Every driver-operated service door shall be capable of operation by the driver when in the driving seat using controls which, except in the case of a foot control, are clearly and distinctively marked.
- 5.6.5.4. Every power-operated service door shall activate a visual tell-tale, which shall be plainly visible to the driver when seated in the normal driving position in any ambient lighting condition, to warn that a door is not fully closed. This tell-tale shall signal whenever the rigid structure of the door is between the fully open position and a point 30 mm from the fully closed position. One tell-tale may serve for one or more doors. However, no such tell-tale shall be fitted in respect of a front service door which does not comply with the requirements of paragraphs 5.6.5.6.2. and 5.6.5.6.3.
- 5.6.5.5. Where controls are provided for the driver to open and close a power-operated service door, they shall be such that the driver is able to reverse the movement of the door at any time during the closing or opening process.
- 5.6.5.6. The construction and control system of every power-operated service door shall be such that a passenger is unlikely to be injured by the door or trapped in the door as it closes.

- 5.6.5.6.1. Except in the case of the front service door, this requirement shall be considered satisfied if the following two requirements are met:
- 5.6.5.6.2. The first requirement is that when the closing of the door at any measuring point described in annex 6 to this Regulation is resisted by a clamping force not exceeding 150 N, the door shall reopen automatically to its fullest extent and, except in the case of an automatically-operated service door, remain open until a closing control is operated. The clamping force may be measured by any method to the satisfaction of the competent authority. Guidelines are given in annex 6 to this Regulation. The peak force may be higher than 150 N for a short time provided that it does not exceed 300 N. The reopening system may be checked by means of a test bar having a section of height 60 mm, width 30 mm with corners radiused to 5 mm.
- 5.6.5.6.3. The second requirement is that whenever the doors are closed onto the wrist or fingers of a passenger:
- 5.6.5.6.3.1. the door reopens automatically to its fullest extent and, except in the case of an automatically-operated service door, remains open until a closing control is operated, or
- 5.6.5.6.3.2. the wrist or fingers can be readily extracted from the doors without risk of injury to the passenger. This requirement may be checked by hand, or by means of the test bar mentioned in paragraph 5.6.5.6.2., tapered at one end over a length of 300 mm from a thickness of 30 mm to a thickness of 5 mm. It shall not be treated with polish nor lubricated. If the door traps the bar it shall be capable of being easily removed, or
- 5.6.5.6.3.3. the door is maintained at a position allowing the free passage of a test bar having a section of height 60 mm, width 20 mm, with corners radiused to 5 mm. This position shall not be more than 30 mm distant from the fully closed position.
- 5.6.5.6.4. In the case of a front service door the requirement of paragraph 5.6.5.6. shall be considered satisfied if the door:
- 5.6.5.6.4.1. fulfils the requirements of paragraphs 5.6.5.6.2. and 5.6.5.6.3., or
- 5.6.5.6.4.2. is fitted with soft edges; these shall not, however be so soft that if the doors are closed on the test bar mentioned in paragraph 5.6.5.6.2. the rigid structure of the doors will reach the fully closed position.

- 5.6.5.7. Where a power-operated service door is held closed only by the continued application of the power supply there shall be provided a visual warning device to inform the driver of any failure in the power supply to the doors.
- 5.6.5.8. A starting prevention device, if fitted, shall be effective only at speeds of less than 5 km/h and shall be incapable of operation above that speed.
- 5.6.5.9. An audible warning to the driver may be activated if the vehicle is driven away from rest when any power-operated service door is not fully closed. This audible warning shall be activated at a speed exceeding 5 km/h for doors complying with the requirements of paragraph 5.6.5.6.3.3.
- 5.6.6. Additional technical requirements for automatically-operated service doors
- 5.6.6.1. Activation of the opening controls.
- 5.6.6.1.1. Except as provided in paragraph 5.6.5.1., the opening controls of every automatically-operated service door shall be capable of being activated and deactivated only by the driver from his seat.
- 5.6.6.1.2. Activation and deactivation may be either direct, by means of a switch, or indirect, for example by opening and closing the front service door.
- 5.6.6.1.3. Activation of the opening controls by the driver shall be indicated inside and, where a door is to be opened from outside, also on the outside of the vehicle; the indicator (e.g. illuminated push button, illuminated sign) shall be on or adjacent to the door to which it relates.
- 5.6.6.1.4. In the case of direct actuation by means of a switch the functional state of the system shall be clearly indicated to the driver, for example by the position of the switch or an indicator lamp or an illuminated switch. The switch shall be specially marked and arranged in such a way that it cannot be confused with other controls.
- 5.6.6.2. Opening of automatically-operated service doors.
- 5.6.6.2.1. After activation of the opening controls by the driver it shall be possible for passengers to open the door as follows:
- 5.6.6.2.1.1. from inside, for example by pressing a push-button or passing a light barrier, and

- 5.6.6.2.1.2. from outside, except in the case of a door intended only as an exit and marked as such, for example by pressing an illuminated push button, a push button beneath an illuminated sign, or a similar device marked with a suitable instruction.
- 5.6.6.2.2. The pressing of the push buttons mentioned in paragraph 5.6.6.2.1.1., and the use of the means of communication with the driver mentioned in paragraph 5.7.9.1., may send a signal which is stored and which, after the activation of the opening controls by the driver, effects the opening of the door.
- 5.6.6.3. Closing of automatically-operated service doors.
- 5.6.6.3.1. When an automatically-operated service door has opened it shall close again automatically after a time interval has elapsed. If a passenger enters or leaves the vehicle during this time interval, a safety device (e.g. a footboard contact, light barrier, one-way gate) shall ensure that the time until the door closes is sufficiently extended.
- 5.6.6.3.2. If the passenger enters or leaves the vehicle while the door is closing, the closing process shall be interrupted automatically and the door shall return to the open position. The reversal may be actuated by one of the safety devices referred to in paragraph 5.6.6.3.1. or by any other device.
- 5.6.6.3.3. A door that has closed automatically in accordance with paragraph 5.6.6.3.1. shall be capable of being opened again by a passenger in accordance with paragraph 5.6.6.2.; this shall not apply if the driver has deactivated the opening controls.
- 5.6.6.3.4. After deactivation of the opening controls of the automatically-operated service doors by the driver, open doors shall close in accordance with paragraphs 5.6.6.3.1. and 5.6.6.3.2.
- 5.6.6.4. Inhibition of the automatic closing process on doors marked for special service, e.g. for passengers with prams, disabled persons, etc.
- 5.6.6.4.1. The driver shall be able to inhibit the automatic closing process by actuation of a special control. A passenger shall also be able to inhibit the automatic closing process directly by pressing a special push button.
- 5.6.6.4.2. The inhibition of the automatic closing process shall be indicated to the driver, e.g. by a visual tell-tale.
- 5.6.6.4.3. Reestablishment of the automatic closing process shall in any case be capable of being done only by the driver.

- 5.6.6.4.4. Paragraph 5.6.6.3. shall apply to the subsequent closing of the door.
- 5.6.7. Technical requirements for emergency doors
- 5.6.7.1. Emergency doors shall be capable of being easily opened from inside and from outside when the vehicle is stationary. However, this requirement shall not be construed as precluding the possibility of locking the door from the outside provided that the door can always be opened from the inside by the use of the normal opening mechanism.
- 5.6.7.2. Emergency doors shall not be of the power-operated or of the sliding type.
- 5.6.7.3. The outside handles of emergency doors shall be not more than 180 cm above the ground when the vehicle is standing unladen on level ground.
- 5.6.7.4. Emergency doors fitted to the side of the vehicle shall be hinged at their forward edge and shall open outwards. Check straps, chains or other restraining devices shall be permitted, provided that they do not prevent the door from opening to, and remaining open at, an angle of at least 100°. If a means is provided sufficient to give free passage to the emergency door access gauge, the 100° minimum angle shall not apply.
- 5.6.7.5. If an emergency door is located adjacent to a door to a toilet or other internal compartment, the emergency door shall be proofed against unintentional operation. However, this requirement shall not apply if the emergency door is locked automatically when the vehicle is moving at a speed exceeding 5 km/h.
- 5.6.7.6. If the driver's service door is not readily accessible, in particular if it is necessary to squeeze between the steering wheel and the driver's seat in order to reach the service door, the service door shall not be deemed to be an emergency door.
- 5.6.7.7. All emergency doors which cannot easily be seen from the driver's seat shall be provided with an audible device to warn the driver when they are not securely closed. The warning device shall be operated by movement of the door catch and not by movement of the door itself.
- 5.6.8. Technical requirements for emergency windows
- 5.6.8.1. Every hinged emergency window shall open outwards.
- 5.6.8.2. Every emergency window shall:

5.6.8.2.1. either be capable of being easily and instantaneously operated from inside and from outside the vehicle by means of a device recognized as satisfactory by the competent authority,

5.6.8.2.2. or be made of readily-breakable safety glass. This latter provision precludes the possibility of using panes of laminated glass or of plastic material.

5.6.8.3. Every emergency window which can be locked from the outside shall be so constructed as to be capable of being opened at all times from inside the vehicle.

5.6.8.4. Every emergency window which is hinged at the top shall be provided with an appropriate mechanism to hold it open.

5.6.8.5. The height of the lower edge of an emergency window fitted in the side of the vehicle from the level of the floor immediately below it shall be not more than 100 cm nor less than 65 cm in the case of a hinged emergency window, or 50 cm in the case of a window made of breakable glass.

However, in the case of a hinged emergency window the height of the lower edge may be reduced to a minimum of 50 cm provided that the window aperture is equipped with a guard up to a height of 65 cm to prevent the possibility of passengers falling out of the vehicle. Where the window aperture is equipped with a guard, the size of the window aperture above the guard shall not be less than the minimum size prescribed for an emergency window.

5.6.8.6. Every hinged emergency window which is not clearly visible from the driver's seat shall be fitted with an audible warning device to warn the driver when it is not completely closed. The window lock, and not the movement of the window itself, shall actuate this device.

5.6.9. Technical requirements for escape hatches

5.6.9.1. Every escape hatch shall operate so as not to obstruct the clear passage from inside or outside the vehicle.

5.6.9.2. Roof escape hatches shall be either ejectable, hinged or made of readily breakable safety glass. Floor hatches shall be either hinged or ejectable and shall be fitted with an audible warning device to warn the driver when it is not securely closed. The floor escape hatch lock, and not the movement of the hatch itself, shall actuate this device. Floor escape hatches shall be proofed against unintentional operation. However this requirement shall not apply if the floor

hatch is locked automatically when the vehicle is moving at a speed exceeding 5 km/h.

- 5.6.9.3. Ejectable types shall not become totally detached from the vehicle when operated such that the hatch is not a danger to other road users. The operation of ejectable escape hatches shall be such that inadvertent operation is effectively prevented. Floor ejectable hatches shall eject only into the passenger compartment.
- 5.6.9.4. Hinged escape hatches shall hinge along the edge towards the front or rear of the vehicle and shall hinge through an angle of at least 100 degrees. Hinged floor escape hatches shall hinge into the passenger compartment.
- 5.6.2.9.5. Escape hatches shall be capable of being easily opened or removed from the inside and from the outside. However, this requirement shall not be construed as precluding the possibility of locking the escape hatch for the purpose of securing the vehicle when unattended, provided that the escape hatch can always be opened or removed from the inside by the use of the normal opening or removal mechanism. In the case of a readily-breakable hatch, a device shall be provided adjacent to the hatch, readily available to persons inside the vehicle, to ensure that the hatch can be broken.
- 5.6.10. Technical requirements for retractable steps
- Retractable steps if fitted shall comply with the following requirements:
- 5.6.10.1. Their operation shall be synchronized with that of the corresponding service or emergency door;
- 5.6.10.2. When the door is closed no part of the retractable step shall project more than 10 mm beyond the adjacent line of the bodywork;
- 5.6.10.3. When the door is open and the retractable step is in the extended position, the surface area shall conform to the requirements of paragraph 5.7.7. of this Regulation;
- 5.6.10.4. It shall not be possible for the vehicle to move from rest, under its own power, when the step is in the extended position;
- 5.6.10.5. The step shall not be capable of being extended when the vehicle is in motion. If the device to operate the step fails, the step shall retract and remain in the retracted position. However, the operation of the corresponding door shall not be hindered in the event of such a failure, or if the step is damaged;

- 5.6.10.6. When a passenger is standing on the retractable step, the corresponding door shall be incapable of being closed. Compliance with this requirement shall be checked by placing a mass of 15 kg. representing a small child, at the centre of the step. This requirement shall not apply to any door within the driver's direct field of view;
- 5.6.10.7. The movement of the retractable step shall not be liable to cause any bodily harm either to passengers or to persons waiting at bus stops;
- 5.6.10.8. The corners of retractable steps facing forwards or rearwards shall be rounded to a radius of not less than 5 mm; the edges shall be rounded to a radius of not less than 2.5 mm;
- 5.6.10.9. When the passenger door is open, the retractable step shall be securely held in the extended position. When a mass of 136 kg is placed in the centre of a single step or a mass of 272 kg is placed in the centre of a double step the deflection at any point on the step shall not exceed 10 mm.
- 5.6.11. Markings
- 5.6.11.1. Each emergency exit shall be marked by an inscription reading "Emergency exit" inside and outside the vehicle.
- 5.6.11.2. The emergency controls of service doors and of all emergency exits shall be marked as such inside and outside the vehicle either by a representative symbol or by a clearly-worded inscription.
- 5.6.11.3. Clear instructions concerning the method of operation shall be placed on or close to every emergency control of an exit.
- 5.6.11.4. The language in which the markings referred to in paragraphs 5.6.11.1. to 5.6.11.3. above are to be inscribed shall be determined by the competent administrative department of the country of registration of the vehicle.
- 5.7. Interior arrangements
- 5.7.1. Access to service doors (see annex 3, figure 1)
- 5.7.1.1. The free space extending inwards into the vehicle from the side wall in which the door is mounted shall permit the free passage of a vertical rectangular panel 10 cm thick, 40 cm wide and 70 cm in height above the floor, having a second panel 55 cm wide superimposed symmetrically above it; the height of the second panel being as prescribed for the relevant class of vehicle.

The dual panel shall be maintained parallel with the door aperture as it is moved from the starting position, where the plane of the face nearest to the interior of the vehicle is tangential to the outermost edge of the aperture, to the position where it touches the first step, after which it shall be kept at right angles to the probable direction of motion of a person using the entrance.

- 5.7.1.2. For vehicles of Class I, the height of the upper rectangular panel shall be 110 cm. For Class II vehicles, the height shall be 95 cm and for Class III vehicles, it shall be 85 cm.
As an alternative, a trapezoidal section, having a height of 50 cm, forming the transition between the width of the upper and the lower panel, may be used. In this case, the total height of the rectangular section and this trapezoidal section of the upper panel shall be 110cm for all classes of vehicles.
- 5.7.1.3. When the centre line of this dual panel has traversed a distance of 30 cm from its starting position and the dual panel is touching the step surface it shall be retained in that position.
- 5.7.1.4. The cylindrical figure (see annex 3, figure 3) used for testing the gangway clearance shall then be moved starting from the gangway, in the probable direction of motion of a person leaving the vehicle, until its centre line has reached the vertical plane which contains the top edge of the uppermost step, or until a plane tangential to the upper cylinder touches the dual panel, whichever occurs first, and retained in that position (see annex 3, figure 9).
- 5.7.1.5. Between the cylindrical figure, at the position set out in paragraph 5.7.1.4. and the dual panel, at the position set out in paragraph 5.7.1.3., there shall be a free space whose upper and lower limits are shown in annex 3, figure 9. This free space shall permit the free passage of a vertical panel whose form and dimensions are the same as the cylindrical form (paragraph 5.7.5.1.), central section and a thickness of no more than 2cm. This panel shall be moved, from the cylindrical form tangential position, until its external side is in contact with the dual panel interior side, touching the plane or planes defined by the step upper edges, in the probable direction of motion of a person using the entrance (see annex 3, figure 9).
- 5.7.1.6. The free passage clearance for this figure shall not include any space extending to 30 cm in front of any uncompressed seat cushion and to the height of the top of the seat cushion.
- 5.7.1.7. In the case of a folding seat, this space shall be determined with the seat in the position of use.

- 5.7.1.8. However, a folding seat for use by the crew may obstruct the access passage to a service door when in the position of use provided that:
- 5.7.1.8.1. it is clearly indicated, both in the vehicle itself and on the communication form (see annex 1), that the seat is for the use of crew only,
- 5.7.1.8.2. when the seat is not in use it folds automatically as necessary to enable the requirements of paragraphs 5.7.1.1. or 5.7.1.2. and 5.7.1.3., 5.7.1.4. and 5.7.1.5. to be met;
- 5.7.1.8.3. the door is not considered to be a mandatory exit for the purpose of paragraph 5.6.1.5.,
- 5.7.1.8.4. the seat is fitted with a retractable safety-belt, and
- 5.7.1.8.5. when the seat is in the position of use, and when it is in the folded position, no part of it shall be forward of a vertical plane passing through the centre of the seating surface of the driver's seat in its rearmost position and through the centre of the exterior rear-view mirror mounted on the opposite side of the vehicle.
- 5.7.1.9. The maximum slope of the floor in the access passage shall not exceed 5 per cent when the unladen vehicle is standing on a smooth and horizontal surface in its normal condition of travel (in particular: any kneeling device shall not be engaged).
- 5.7.1.10. Gangways and access passages shall be covered with an anti-slip material.
- 5.7.2. Access to emergency doors (see annex 3, figure 2)
- 5.7.2.1. The free space between the gangway and the emergency door aperture shall permit the free passage of a vertical cylinder 30 cm in diameter and 70 cm high from the floor and supporting a second vertical cylinder 55 cm in diameter, the aggregate height of the assembly being 140 cm.
- 5.7.2.2. The base of the first cylinder shall be within the projection of the second cylinder.
- 5.7.2.3. Where folding seats are installed alongside this passage, the free space for the cylinder shall be required to be determined when the seat is in the opened position.

5.7.3. Access to emergency windows

5.7.3.1. It shall be possible to move a test gauge from the gangway to the exterior of the vehicles through every emergency window.

5.7.3.2. The direction of motion of the test gauge shall be in the direction in which a passenger evacuating the vehicle would be expected to move. The test gauge shall be kept perpendicular to that direction of motion.

5.7.3.3. The test gauge shall be in the form of a thin plate having a size of 60 x 40 cm with corners radiused by 20 cm. However, in the case of an emergency window in the rear face of the vehicle, the test gauge may alternatively have a size of 140 cm x 35 cm with corners radiused by 17.5 cm.

5.7.4. Access to escape hatches

5.7.4.1. Escape hatches in the roof

5.7.4.1.1. Except in the case of Class I vehicles, at least one escape hatch shall be located such that a four-sided truncated pyramid having a side angle of 20° and a height of 1,600 mm touches part of a seat or equivalent support. The axis of the pyramid shall be vertical and its smaller section shall contact the aperture area of the escape hatch. Supports may be foldable or movable provided they can be locked in their position of use. This position shall be taken for verification.

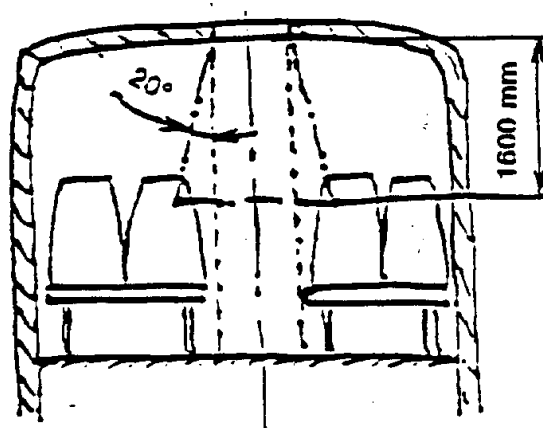

5.7.4.1.2. When the structural thickness of the roof is more than 150 mm, the smaller section of the pyramid shall contact the aperture area of the escape hatch at the level of the outside surface of the roof.

5.7.4.2. Escape hatches in the floor

In the case of an escape hatch fitted in the floor, the hatch shall give direct and free access to the exterior of the vehicle and be fitted where there is a clear space above the hatch equivalent to the height of the gangway. Any heat source or moving components shall be at least 500 mm from any part of the hatch aperture.

It shall be possible to move a test gauge in the form of a thin plate having 600 mm x 400 mm with corners radiused by 200 mm in a horizontal position from a height above the floor of the vehicle of 1.00 m to the ground.

5.7.5. Gangways (see annex 3, figure 3)

5.7.5.1. The gangway of a public service vehicle shall be so designed and constructed as to permit the free passage of a gauging device consisting of two co-axial cylinders with an inverted truncated cone interposed between them, the gauging device having the following dimensions (in cm):

	Class I	Class II	Class III
Diameter of lower cylinder	45	35	30
Height of lower cylinder	90	90	90
Diameter of upper cylinder	55	55	45
Height of upper cylinder	50	50	50
Overall height	190	190	190

The gauging device may come into contact with strap hangers, if fitted, and move them away.

5.7.5.2. On vehicles of Class I, the diameter of the lower cylinder may be reduced from 45 cm to 40 cm in any part of the gangway which is located to the rear of the most forward of the following two planes:

5.7.5.2.1. a transverse vertical plane situated 1.5 m forward of the centre line of the rear axle (foremost rear axle in the case of vehicles with more than one rear axle);

5.7.5.2.2. a transverse vertical plane situated at the rear edge of the rearmost service door in between the axles.

- 5.7.5.2.3. For the purpose of the application of paragraphs 5.7.5.2.1. and 5.7.5.2.2. above, each rigid section of an articulated vehicle shall be considered separately.
- 5.7.5.3. On vehicles of Class III the seats on one side or on both sides of the gangway may be movable laterally, it being then possible to reduce the width of the gangway to a figure corresponding to a lower cylinder diameter of 22 cm, on condition that the operation of a control on each seat, readily accessible to a person standing in the gangway, shall be sufficient to cause the seat to return automatically, even when it is loaded, to the position corresponding to a minimum width of 30 cm.
- 5.7.5.4. The height of the upper cylinder may be reduced by 10 cm in any part of the gangway which is located to the rear of the most forward of the following two planes:
- 5.7.5.4.1. a transverse vertical plane situated 1.5 m forward of the centre line of the rear axle (foremost rear axle in the case of vehicles with more than one rear axle).
- 5.7.5.4.2. a transverse vertical plane situated at the rear edge of the rearmost service door.
- 5.7.5.4.3. For the purpose of the application of paragraphs 5.7.5.4.1. and 5.7.5.4.2. above, each rigid section of an articulated vehicle shall be considered separately.
- 5.7.5.5. On articulated buses or coaches, the gauging device defined in paragraph 5.7.5.1. shall be able to pass unobstructed through the articulated section. No part of the soft covering of that section, including parts of bellows, shall project into the gangway.
- 5.7.5.6. Steps may be fitted in the gangways. The width of such steps shall not be less than the width of the gangway at the top of the steps.
- 5.7.5.7. Folding seats allowing passengers to sit in the gangway shall not be permitted.
- 5.7.5.8. Laterally-sliding seats which in one position encroach on the gangway shall not be permitted except on vehicles of Class III and subject to the conditions prescribed in paragraph 5.7.5.3.
- 5.7.6. Slope of gangway
- The slope of gangway shall not exceed:
- 5.7.6.1. In the longitudinal direction:

5.7.6.1.1. 8 per cent in the case of a vehicle of Class I or Class II, or

5.7.6.1.2. 12.5 per cent in the case of a vehicle of Class III.

5.7.6.2. In the transversal direction 5 per cent for all classes.

5.7.7. Steps (See annex 3, figure 4)

5.7.7.1. The maximum and minimum height, and the minimum depth, of steps for passengers at service and emergency doors and within the vehicle are specified in annex 3, figure 4.

		Class I	Class II	Class III
First step from ground	Max. height (cm)	36 <u>1/</u>	40 <u>1/</u> <u>2/</u>	
	Max. depth (cm)	30		
Other steps	Max. height (cm)	25 <u>3/</u>	35	
	Min. height (cm)	12		
	Min. depth (cm)	20		

1/ 70 cm in the case of an emergency door.

2/ 43 cm in the case of a vehicle with solely mechanical suspension.

3/ 30 cm in the case of steps at a door behind the rearmost axle.

5.7.7.2. For the purposes of this paragraph, the height of a step shall be measured at the centre of its width. Furthermore, manufacturers should specifically take account of access by the handicapped, particularly in relation to step height in Class I being kept to a minimum.

5.7.7.3. Any transition from a sunken gangway to a seating area shall not be considered to be a step. However, the vertical distance between the gangway surface and the floor of the seating area shall not exceed 35 cm.

5.7.7.4. The height of the first step in relation to the ground shall be measured with the vehicle unladen, the tyre equipment and pressure being as specified by the manufacturer for the maximum technical mass declared in accordance with paragraph 3.2.3.

- 5.7.7.5. Where there is more than one step, each step may extend into the area of the vertical projection of the next step by up to 10 cm and the projection over the tread below shall leave a free surface of at least 20 cm in depth (see annex 3, figure 4) with all step nosings being designed such as to minimise the risk of tripping and being in a light, contrasting colour.
- 5.7.7.6. The width and shape of every step shall be such that a rectangle of 40 x 30 cm in the case of a first step, and 40 x 20 cm in the case of any other step, can be placed on it with not more than 5 per cent of the area of the appropriate rectangle overhanging the step. At a double doorway each half of the doorway shall fulfil this requirement.
- 5.7.7.7. The maximum slope of the step in any direction shall not exceed 5 per cent when the unladen vehicle is standing on a smooth and horizontal surface in its normal condition of travel (in particular: any kneeling device shall not be engaged).
- 5.7.8. Passenger seats (including folding seats) and space for seated passengers
- 5.7.8.1. Minimum seat width (see annex 3, figure 5)
- 5.7.8.1.1. The minimum width of a seat cushion, measured from a vertical plane passing through the centre of that seating position, shall be:
- 5.7.8.1.1.1. 20 cm in vehicles of Class I and Class II.
- 5.7.8.1.1.2. 22.5 cm in vehicles of Class III.
- 5.7.8.1.2. The minimum width of the available space for each seating position, measured from a vertical plane passing through the centre of that seating position at heights between 27 and 65 cm above the uncompressed seat cushion, shall be:
- 5.7.8.1.2.1. 25 cm in the case of individual seats, and
- 5.7.8.1.2.2. 22.5 cm in the case of continuous seats for two or more passengers.
- 5.7.8.2. Minimum depth of seat cushion (see annex 3, figure 7)
- The minimum depth of a seat cushion shall be:
- 5.7.8.2.1. 35 cm in vehicles of Class I, and
- 5.7.8.2.2. 40 cm in vehicles of Class II and Class III.

5.7.8.3. Height of seat cushion (see annex 3, figure 6)

The height of the uncompressed seat cushion relative to the floor shall be such that the distance from the floor to a horizontal plane tangent to the front upper surface of the seat cushion is between 40 and 50 cm: this height may however be reduced to not less than 35 cm at the wheel arches and at the engine compartment.

5.7.8.4. Seat spacing (see annex 3, figure 6)

5.7.8.4.1. In the case of seats facing in the same direction, the distance between the front of a seat squab and the back of the squab of the seat preceding it, shall, when measured horizontally and at all heights above the floor between the level of the top surface of the seat cushion and a point 62 cm above the floor, not be less than:

Class I	65 cm
Class II	68 cm
Class III	68 cm

5.7.8.4.2. All measurements shall be taken, with the seat cushion and squab uncompressed, in a vertical plane passing through the centreline of the individual seating place.

5.7.8.4.3. Where transverse seats face one another the minimum distance between the front faces of the seat squabs of facing seats, as measured across the highest points of the seat cushions, shall be not less than 130 cm.

5.7.8.5. Space for seated passengers (see annex 3, figure 8)

5.7.8.5.1. A minimum clear space in front of each passenger seat shall be provided as shown in annex 3, figure 8. The seat-back of another preceding seat or a partition whose contour corresponds approximately to that of the inclined seat back may intrude into this space as provided by paragraph 5.7.8.4. The local presence in this space of seat legs shall also be permitted provided that adequate space remains for the passenger's feet.

5.7.8.5.2. However, at least 2 forward or rearward facing seats specifically intended and marked for disabled passengers shall be provided in that part of the vehicle which is most suitable for boarding. These seats shall be designed for the disabled so as to provide enough space, shall have suitably designed and placed

hand-holds to facilitate entry and exit of the seat and provide communication in accordance with paragraph 5.7.9.1. from the seated position.

5.7.8.6. Free height over seating positions

5.7.8.6.1. Each seating position shall have a free height of not less than 90 cm measured from the highest point of the uncompressed seat cushion. This free height shall extend over the vertical projection of the whole area of the seat and the associated foot space.

5.7.8.6.2. In the space extending above the area mentioned in paragraph 5.7.8.6.1., the following intrusions shall be permitted:

5.7.8.6.2.1. Intrusion of the back of another seat;

5.7.8.6.2.2. Intrusion of a structural member provided that the intrusion is included within a triangle whose peak is situated 65 cm from the floor and whose base is 10 cm in width and situated in the upper part of the space in question, adjacent to the side wall of the vehicle (see annex 3, figure 10);

5.7.8.6.2.3. Intrusion of a conduit (e.g. for hot air) situated in the lower part of the space in question, adjacent to the sidewall of the vehicle, of a cross-sectional area not exceeding 200 cm² and having a maximum width of 10 cm (see annex 3, figure 11).

5.7.8.6.2.4. Intrusion of hopper type windows when open and their fittings.

5.7.9. Communication with the driver

5.7.9.1. In the case of a vehicle of Class I or Class II a means shall be provided to enable passengers to signal to the driver that he should stop.

5.7.9.2. If a crew compartment is fitted without access to the driver or passenger compartments, a means of communication between the driver and this crew compartment shall be provided.

5.7.10. Hot drink machines and cooking equipment

Hot drink machines and cooking equipment shall be so installed or guarded that no hot food or drink is likely to be spilled on any seated passenger due to emergency braking or cornering forces.

5.7.11. Doors to interior compartments

Every door to a toilet or other interior compartment:

- 5.7.11.1. shall be self-closing, and shall not be fitted with any device to hold it open if, when open, it could obstruct passengers in an emergency,
- 5.7.11.2. shall, when open, not conceal any handle or control for opening any service or emergency door, and
- 5.7.11.3. shall be provided with a means to enable the door to be opened from outside the compartment in an emergency,
- 5.7.11.4. shall not be capable of being locked from the outside unless it can always be opened from the inside.

5.8. Artificial interior lighting

5.8.1. Internal electrical lighting shall be provided for the illumination of:

- 5.8.1.1. all passenger compartments and the articulated section of an articulated bus;
- 5.8.1.2. any step or steps;
- 5.8.1.3. the access to any exits;
- 5.8.1.4. the internal markings and internal controls of all exits;
- 5.8.1.5. all places where there are obstacles.

5.9. Articulated section of articulated buses or coaches

- 5.9.1. The articulated section that interconnects rigid portions of the vehicle shall be so designed and constructed as to allow a rotary movement about a horizontal axis and a vertical axis.
- 5.9.2. When the articulated bus or coach at its unladen kerb mass is stationary on a horizontal level surface, there shall not be between the floor of either of the rigid sections and the floor of the rotating base or of the element replacing that base an uncovered gap of a width exceeding:
 - 5.9.2.1. 1 cm when all the wheels of the vehicle are on the same plane, or

- 5.9.2.2. 2 cm when the wheels of the axle adjacent to the articulated section are resting on a surface which is 15 cm higher than the surface on which the wheels of the other axles are resting.
- 5.9.3. The difference in level between the floor of the rigid portions and the floor of the rotating base, measured at the joint, shall not exceed:
- 5.9.3.1. 2 cm in the conditions described in paragraph 5.9.2.1. above, or
- 5.9.3.2. 3 cm in the conditions described in paragraph 5.9.2.2. above.
- 5.9.4. On articulated buses or coaches, handrails and/or partitions shall prevent access by passengers to any part of the articulated section where:
- (a) the floor has an uncovered gap not complying with the requirements of paragraph 5.9.2.;
 - (b) the floor cannot carry the mass of the passengers; or
 - (c) the movements of the walls constitute a danger to passengers.
- 5.10. Manoeuvrability
- 5.10.1. The vehicle shall be able to manoeuvre on either lock inside a circle of 12.5 m radius without any of its outermost points projecting outside the circumference of the circle.
- 5.10.2. When the outermost points of the vehicle are moving on either lock on a circle of 12.5 m radius the vehicle shall be able to move within the limits of a circular track 7.2 m wide (see annex 4, figures A/B).
- 5.10.3. With the vehicle stationary, a vertical plane tangential to the side of the vehicle and facing outwards from the circle shall be established by marking a line on the ground. In the case of an articulated vehicle the two rigid portions shall be aligned with the plane. When the vehicle moves from a straight line approach into the circular area described in paragraphs 5.10.1. and 5.10.2. above, no part of it shall move outside of this vertical plane by more than 0.8 m (see annex 4, figure A) in the case of a rigid vehicle, or by more than 1.2 m (see annex 4, figure B) in the case of an articulated vehicle.
- 5.10.4. In the case of a vehicle fitted with an axle with an unloading device, these requirements shall in each case be fulfilled with the axle in the most unfavourable condition.

5.11. Direction-holding of articulated buses or coaches

When an articulated bus or coach is moving in a straight line, the longitudinal median planes of its rigid portion shall coincide and form a continuous plane without any deflection.

5.12. Hand-rails and hand-holds

5.12.1. General requirements

5.12.1.1. Hand-rails and hand-holds shall be of adequate strength.

5.12.1.2. They shall be so designed and installed as to present no risk of injury to passengers.

5.12.1.3. Handrails and hand-holds shall be of a section enabling passengers to grasp them easily and firmly. Every handrail shall provide a length of at least 10 cm to accommodate a hand. No dimension of the section shall be smaller than 2 cm or greater than 4.5 cm except in the case of handrails on doors and seats and, in the case of a vehicle of Class II or Class III, in access passages. In these cases hand-rails having a minimum dimension of 1.5 cm shall be permitted provided that one other dimension is of at least 2.5 cm.

5.12.1.4. The clearance between a hand-rail or hand-hold and the adjacent part of the vehicle body or walls shall be of at least 4 cm. However, in the case of a handrail on a door or a seat, or in the access passage of a vehicle of Class II or III, a minimum clearance of 3.5 cm shall be permitted.

5.12.1.5. The surface of every hand-rail, hand-hold or stanchion shall be colour contrasting and non-slip.

5.12.2. Hand-rails and hand-holds for standing passengers: vehicles of Class I and Class II

5.12.2.1. Hand-rails and/or hand-holds shall be provided in sufficient number for each point of the floor area intended, in conformity with paragraph 5.2.2. for standing passengers. This requirement shall be deemed to be fulfilled if, for all possible sites of the testing device shown in annex 5 hereto, at least two hand-rails or hand-holds can be reached by the device's movable arm. For this purpose, strap hangers, if fitted, may be counted as hand-holds, provided they are held in their position by suitable means. The testing device may be freely turned about its vertical axis.

- 5.12.2.2. When applying the procedure described in paragraph 5.12.2.1. above, only such hand-rails and hand-holds shall be considered as are not less than 80 cm and not more than 190 cm above the floor.
- 5.12.2.3. For every position that can be occupied by a standing passenger, at least one of the two required hand-rails or hand-holds shall be not more than 150 cm above the level of the floor at that position. Exception may be given in the middle of large platforms, but the sum of these exceptions shall not exceed 20 per cent of the total standing area.
- 5.12.2.4. Areas which can be occupied by standing passengers and are not separated by seats from the side walls or rear wall of the vehicle shall be provided with horizontal hand-rails parallel to the walls and installed at a height of between 80 cm and 150 cm above the floor.
- 5.12.3. Hand-rails and hand-holds for service doors
- 5.12.3.1. Door apertures shall be fitted with hand-rails and/or hand-holds on each side. For double doors, this requirement may be met by the installation of one central stanchion or hand-rail.
- 5.12.3.2. Handrails and/or handholds to be provided for service doors shall be such that they include a grasping point available to a person standing on the ground adjacent to the service door or on any of the successive steps. Such points shall be situated, vertically, between 80 and 110 cm above the ground or above the surface of each step, and horizontally:
- 5.12.3.2.1. for the position appropriate to a person standing on the ground, not more than 40 cm inwards from the outer edge of the first step; and
- 5.12.3.2.2. for the position appropriate to a particular step, not outwards from the outer edge of the step considered, and not more than 60 cm inwards from that same edge.
- 5.12.4. Hand-rails and hand-holds for the handicapped
- Hand-rails and hand-holds between the service door and the seats specially identified in accordance with paragraph 5.7.8.5.2. shall be designed to specifically take into account the needs of the handicapped.

5.13. Guarding of stepwells

Where any seated passenger is likely to be thrown forward into a stepwell as a result of heavy braking, a guard shall be fitted. The guard shall have a minimum height from the floor on which the passenger's feet rest of 80 cm and shall extend inwards from the wall of the vehicle at least as far as 10 cm beyond the longitudinal centre line of any seating position where the passenger is at risk or to the riser of the innermost step; whichever is the lesser dimension.

5.14. Luggage racks, driver protection

The driver shall be protected from objects liable to fall from luggage racks in the case of heavy braking.

5.15. Trap doors

Every trap door in the floor of a vehicle shall be so fitted and secured that it cannot be dislodged or opened without the use of tools or keys and no lifting or securing device shall project by more than 8mm above floor level. Edges of projections shall be rounded.

6. MODIFICATION AND EXTENSION OF APPROVAL OF A VEHICLE TYPE

6.1. Every modification of the vehicle type shall be notified to the administrative department which approved the vehicle type. That department may then either:

6.1.1. consider that the modifications made are unlikely to have an appreciable adverse effect and that, in any case, the vehicle still complies with the requirements; or

6.1.2. require a further test report from the technical service responsible for conducting the tests.

6.2. Confirmation of approval, specifying the modifications, shall be communicated by the procedure specified in paragraph 4.3. above to the Contracting Parties to the Agreement which apply this Regulation.

6.3. The competent authority issuing the extension of approval shall assign a series number for such an extension and inform thereof the other Parties to the 1958 Agreement applying this Regulation by means of a communication form conforming to the model in annex 1 to this Regulation.

7. CONFORMITY OF PRODUCTION

7.1. Every vehicle bearing an approval mark as prescribed under this Regulation shall conform to the vehicle type approved.

7.2. In order to verify conformity as prescribed in paragraph 7.1. above, serially-produced vehicles bearing the approval mark required by this Regulation shall be subjected to a sufficient number of random checks.

8. PENALTIES FOR NON-CONFORMITY OF PRODUCTION

8.1. The approval granted in respect of a vehicle type pursuant to this Regulation may be withdrawn if the requirement laid down in paragraph 7.1. above is not complied with.

8.2. If a Party to the Agreement applying this Regulation withdraws an approval it has previously granted, it shall forthwith notify the other Contracting Parties applying this Regulation, by means of a communication form conforming to the model in annex 1 to this Regulation.

9. PRODUCTION DEFINITELY DISCONTINUED

If the holder of the approval completely ceases to manufacture a type of vehicle under this Regulation, he shall so inform the authority which granted the approval. Upon receiving the relevant communication, that authority shall inform thereof the other Parties to the Agreement applying this Regulation by means of a communication form conforming to the model in annex 1 to this Regulation.

10. TRANSITIONAL PROVISIONS

10.1. As from the official date of entry into force of the 03 series of amendments to this Regulation, no Contracting Party applying this Regulation shall refuse approval under this Regulation as amended by the 03 series of amendments.

10.2. As from 3 years after the official date of entry into force mentioned in paragraph 10.1. above, Contracting Parties applying this Regulation shall grant approvals only if the type of vehicle corresponds to the requirements of this Regulation as amended by the 03 series of amendments.

10.3. As from 6 years after the official date of entry into force mentioned in paragraph 10.1. above, Contracting Parties applying this Regulation may refuse

to recognize approvals which were not granted in accordance with the 03 series of amendments to this Regulation.

11. NAMES AND ADDRESSES OF TECHNICAL SERVICES CONDUCTING APPROVAL TESTS, AND ADMINISTRATIVE DEPARTMENTS

The Parties to the Agreement which apply this Regulation shall communicate to the Secretariat of the United Nations the names and addresses of the technical services responsible for conducting approval tests and of the administrative departments which grant approval and to which forms certifying approval or extension or refusal or withdrawal of approval, issued in other countries, are to be sent.

12. REMARKS CONCERNING PERMISSIBLE AXLE LOADS OR TOTAL VEHICLE MASS

Contracting Parties to the Agreement are not precluded by article 3 of that Agreement from prohibiting the registration on their territory of vehicle types, approved by another Contracting Party in accordance with this Regulation whenever passenger and luggage capacities result in the axle loads or the maximum mass of the vehicle being higher than the legal limits in force on their territory.

Annex 1

COMMUNICATION

(maximum format: A4 (210 x 297 mm))



issued by :

Name of administration:

.....
.....
.....

concerning: 2/

- APPROVAL GRANTED
- APPROVAL EXTENDED
- APPROVAL REFUSED
- APPROVAL WITHDRAWN
- PRODUCTION DEFINITELY DISCONTINUED

of a vehicle type with regard to its general construction pursuant to Regulation No. 36.

Approval No.:

Extension No.:

1. Trade name or mark of the power-driven vehicle:
2. Vehicle type:
3. Name and address of applicant for approval:
.....
4. If applicable, name and address of representative of applicant for approval:
.....
5. Brief description of the vehicle type as regards its structure, dimensions, configuration and constituent materials:
.....
6. Technical maximum mass of vehicle when tested:
 - 6.1. Front axle: (kg)
 - 6.2. Intermediate axle: (kg)

- 6.3. Rear axle:(kg)
- 6.4. Total (PT):(kg)
7. Unladen mass (MV):(kg)
8. Carriage of baggage or goods:
- 8.1. Total volume of baggage compartments or goods compartments (V):
.....(m³)
- 8.2. Total mass of baggage or goods these compartments can contain (B):
.....(kg)
- 8.3. Carriage of baggage or goods on the roof provided for: yes/no 2/
- 8.3.1. Total area of roof equipped for carriage of baggage or goods (VX):
.....(m²)
- 8.3.2. Total mass of baggage or goods which may be carried in this area (BX):.....(kg)
9. Area for passengers:
- 9.1 Total (S_o):(m²)
- 9.2 For standing passengers (S₁):(m²)
10. Calculated values:
- 10.1. Number of seating and standing places according to paragraph 5.3.2. of this Regulation:
- 10.1.1. Total (N = P_s + P_{st}):
- 10.1.2. Seating places (P_s):
- 10.1.3. Standing places (P_{st}):
- 10.2. Masses according to paragraph 5.3.3. of this Regulation:
- 10.2.1. Total vehicle mass:(kg)

- 10.2.2. First axle mass:(kg)
- 10.2.3. Second axle mass:(kg)
- 10.2.4. Third axle mass (if any):(kg)
- 10.2.5. Fourth axle mass (if any):(kg)
11. Vehicle submitted for approval on:
12. Vehicle approved for Class(es):
13. Technical service responsible for conducting approval tests:
.....
14. Date of report issued by that service:
15. Number of report issued by that service:
16. Approval granted/refused/extended/withdrawn 2/
17. Position of approval mark on the vehicle:
18. Place:
19. Date:
20. Signature:
21. The list of documents filed with the administrative service which has granted approval and available on request is annexed to this communication.

1/ Distinguishing number of the country which has granted/extended/refused/withdrawn approval (see approval provisions in the Regulation).

2/ Strike out what does not apply.

Annex 2

ARRANGEMENTS OF APPROVAL MARKS

Model A

(See paragraph 4.4. of this Regulation)

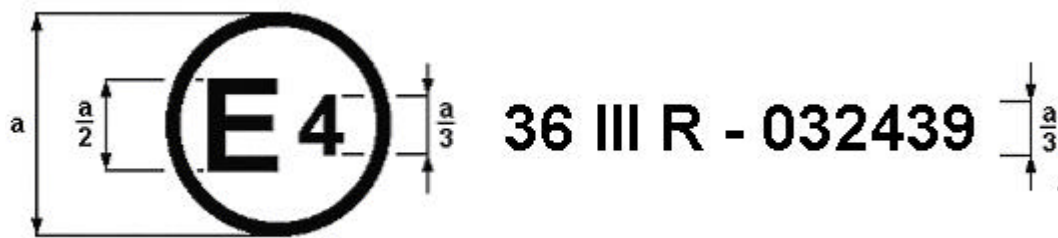

a = 8 mm min.

The above approval mark affixed to a vehicle shows that the vehicle type concerned has, with regard to its constructional features, been approved in the Netherlands (E 4) for Class III, pursuant to Regulation No. 36 under approval number 032439. The approval number indicates that the approval was granted according to the requirements of Regulation No. 36 as amended by the 03 series of amendments.

Model B

(See paragraph 4.5. of this Regulation)

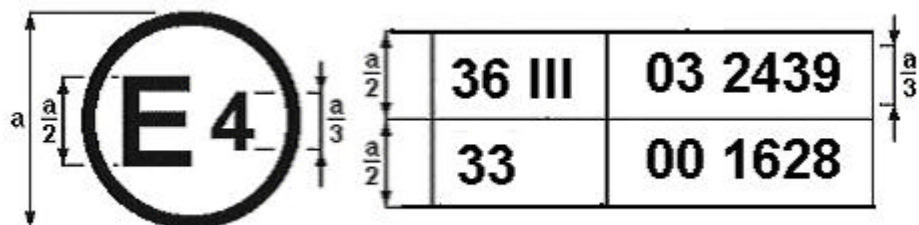

a = 8 mm min.

The above approval mark affixed to a vehicle shows that the vehicle type concerned has been approved in the Netherlands (E 4) pursuant to Regulations Nos. 36 and 33. */ The first two digits of the approval numbers indicate that, at the dates when the respective approvals were given, Regulation No. 36 included the 03 series of amendments and Regulation No. 33 was in its original form.

*/ This number is given merely as an example.

Annex 3

EXPLANATORY DIAGRAMS

Figure 1
 ACCESS TO SERVICE DOORS
 (see paragraph 5.7.1.)

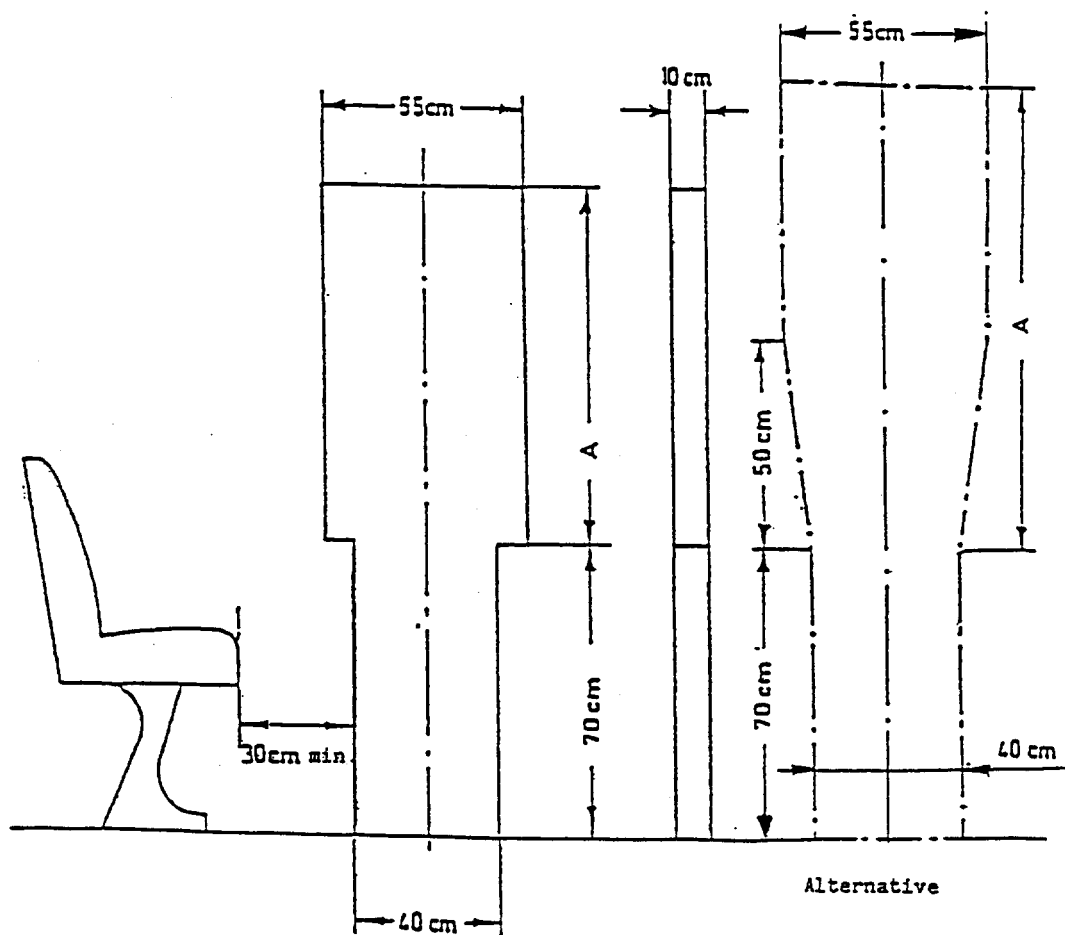

	Dimension A (cm)	Alternative (cm)
Class I	110	110
Class II	95	110
Class III	85	110

Figure 2

ACCESS TO EMERGENCY DOORS
(see paragraph 5.7.2.)

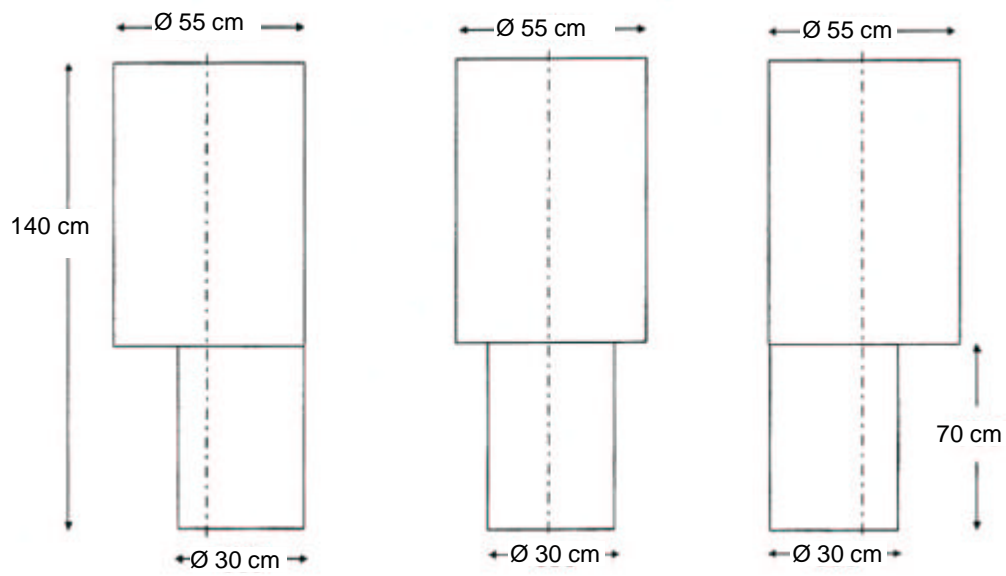
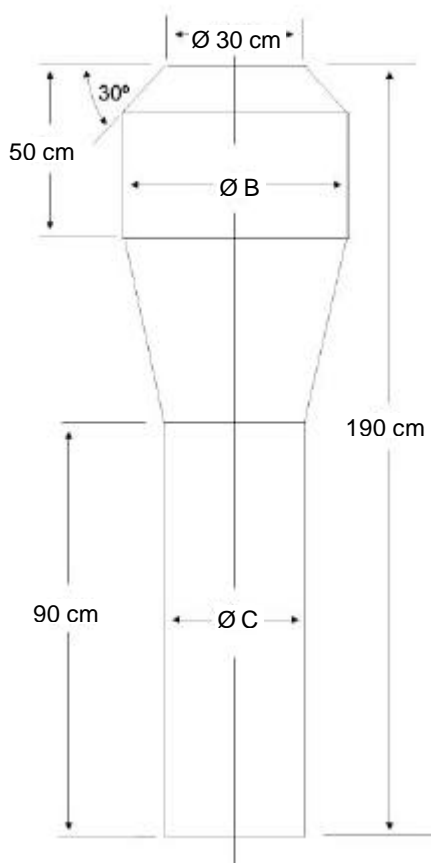

Figure 3

GANGWAYS
 (see paragraph 5.7.5.)



	B (cm)	C (cm)
Class I	55	45
Class II	55	35
Class III	45	30 (22 in the case of laterally movable seats)

Figure 4

STEPS FOR PASSENGERS

(see paragraph 5.7.7.)

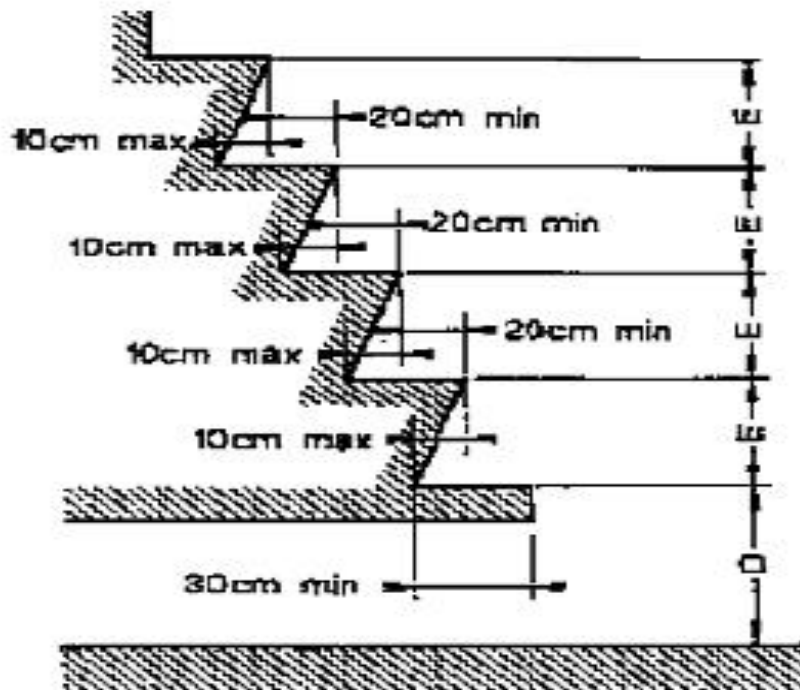

D = Height above the ground, vehicle unladen

	D (cm) <u>1/</u> <u>3/</u>	E (cm) <u>1/</u> <u>2/</u>	
	max.	min.	max.
Class I	36	12	25 <u>4/</u>
Class II; Class III	40	12	35
mechanical suspension solely	43		

- 1/ At a double doorway the steps in each half of the access passage shall be treated separately.
- 2/ E need not be the same for each step.
- 3/ 70 cm in the case of an emergency door.
- 4/ 30 cm in the case of steps at a door behind the rearmost axle.

Figure 5

WIDTH OF PASSENGER SEATS
 (see paragraph 5.7.8.1.)

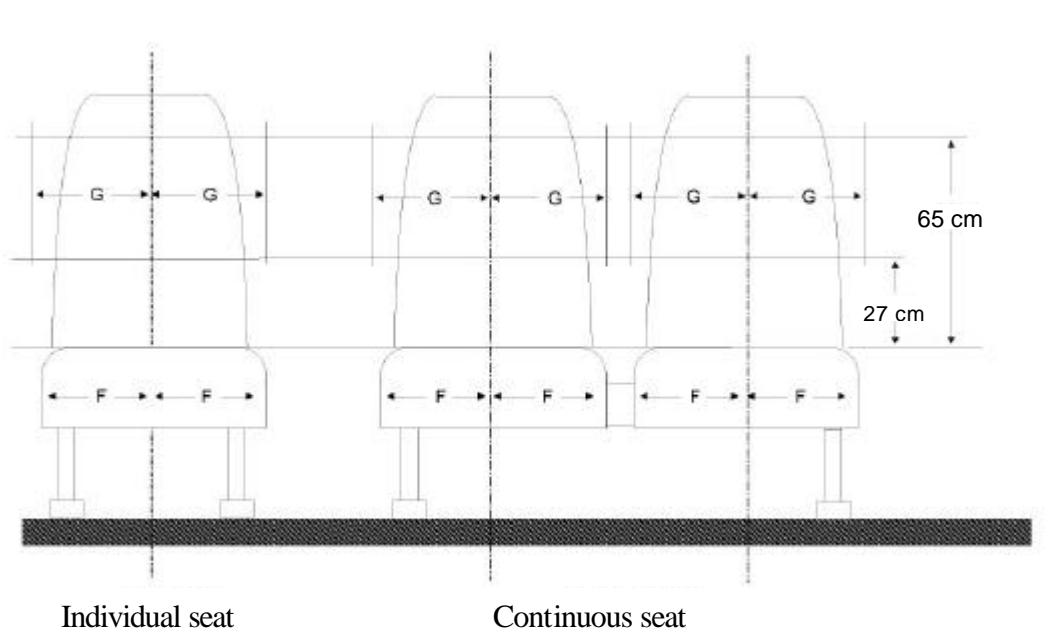

	F (cm) min	G (cm) min	
		Continuous seats	Individual seats
Class I	20	22.5	25
Class II	20	22.5	25
Class III	22.5	22.5	25

Figure 6

SEAT SPACING AND CUSHION HEIGHT
 (see paragraph 5.7.8.3. and 5.7.8.4.)

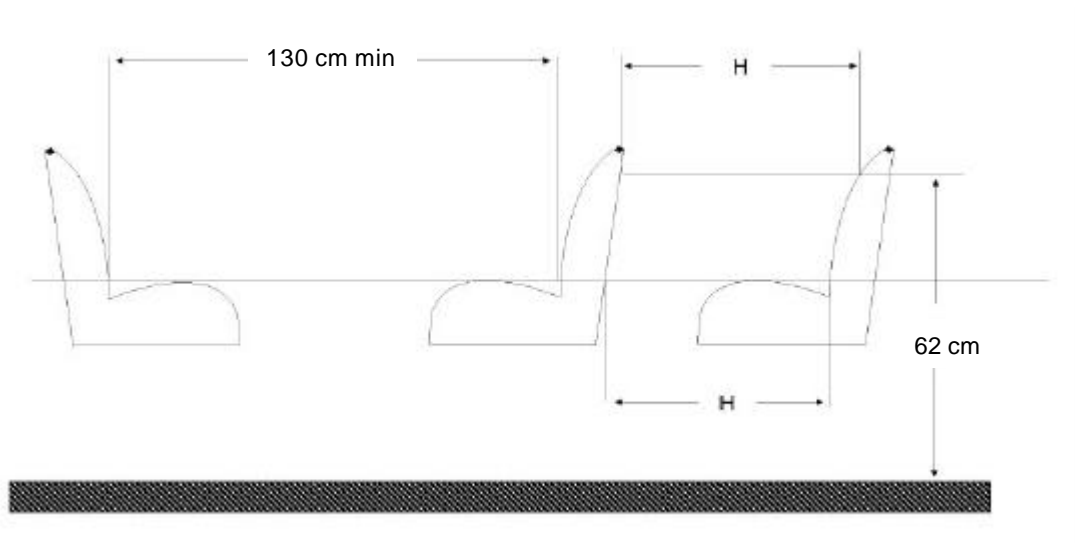

	H (cm) min	I (cm) min
Class I	65	40 - 50 (for Class I and Class II min. 35 cm at wheel arches and engine compartment(s))
Class II	68	
Class III	68	

Figure 7

SEAT CUSHION DEPTH
(see paragraph 5.7.8.2)

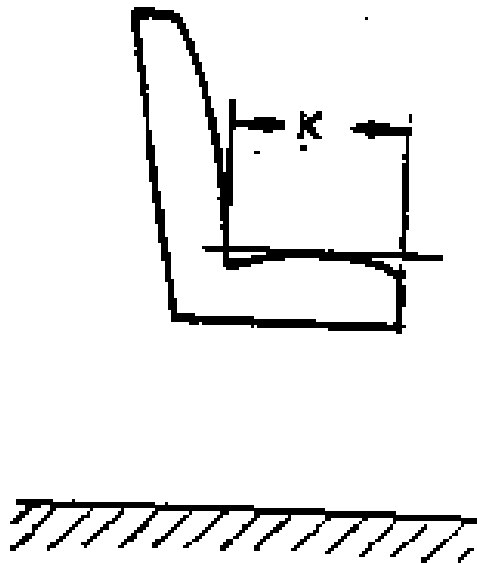

	K (cm) min
Class I	35
Class II	40
Class III	40

Figure 8

SPACE FOR SEATED PASSENGERS
(see paragraph 5.7.8.5.)

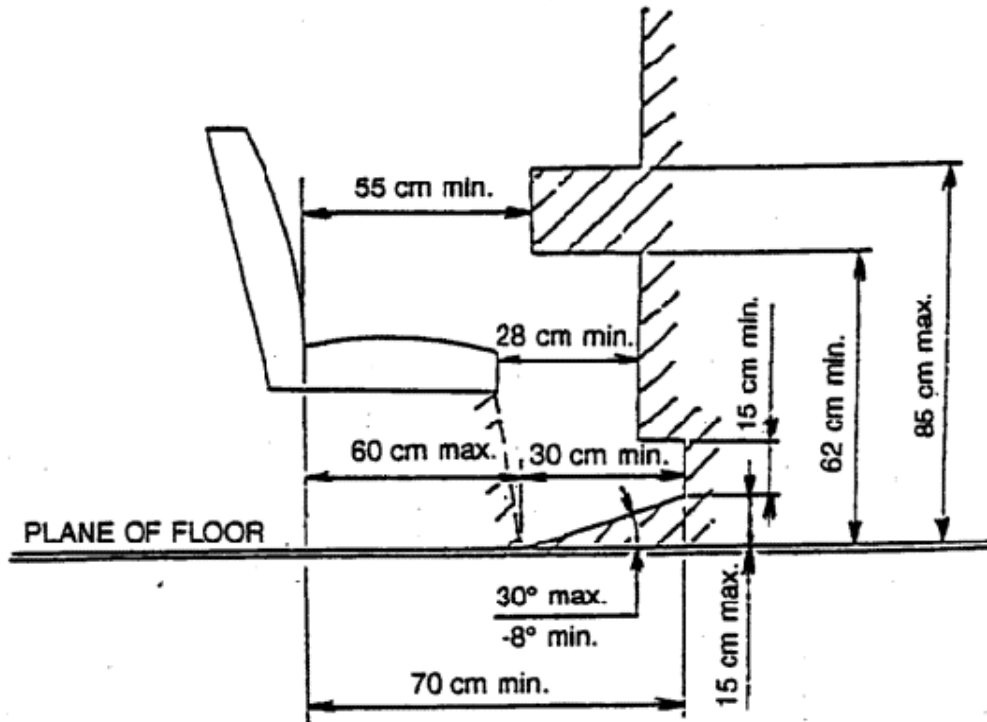

Figure 9

ACCESS TO SERVICE DOORS

(see paragraph 5.7.1.4.)

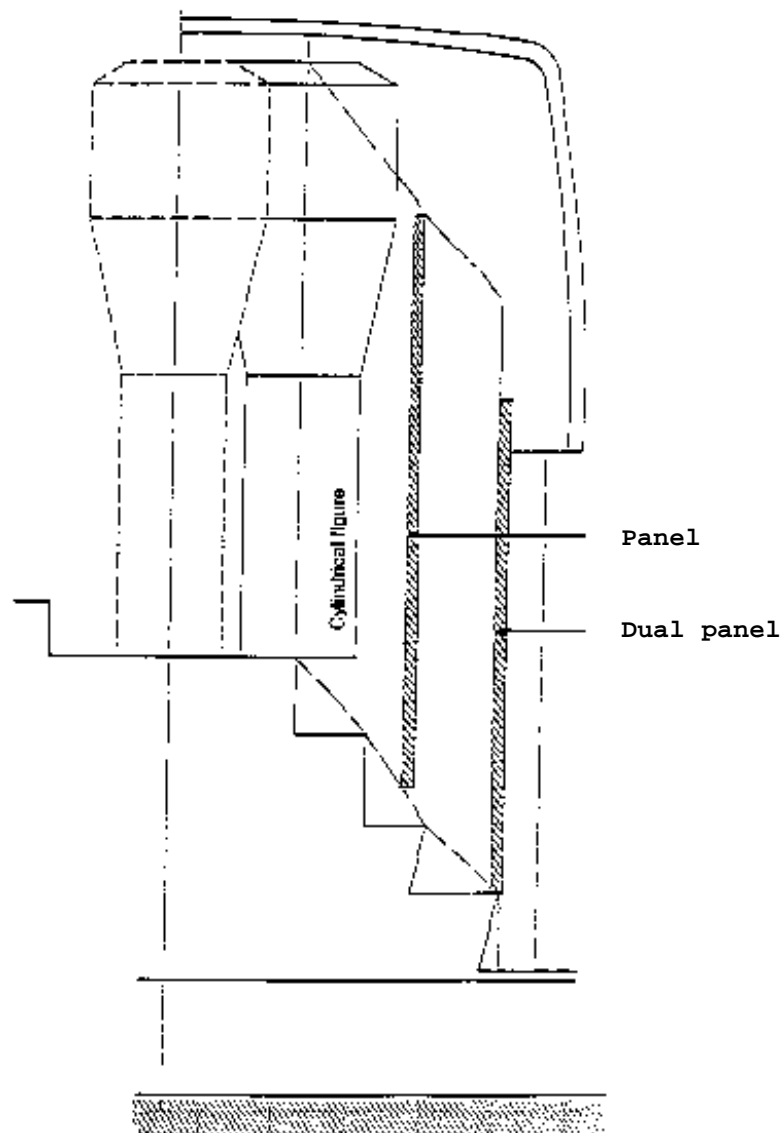

Figure 10

PERMITTED INTRUSION OF A STRUCTURAL MEMBER
(see paragraph 5.7.8.6.2.2.)

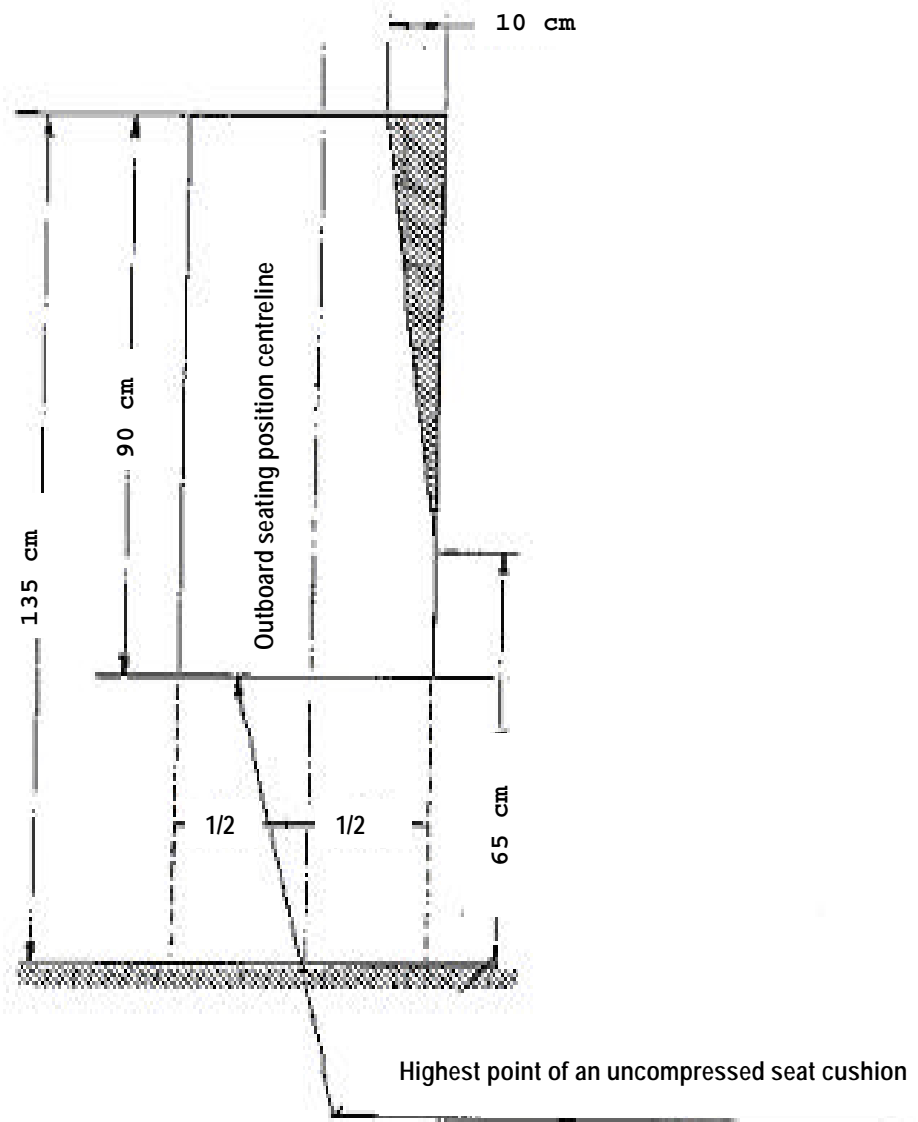

Figure 11

PERMITTED INTRUSION OF A CONDUIT

(see paragraph 5.7.8.6.2.3.)

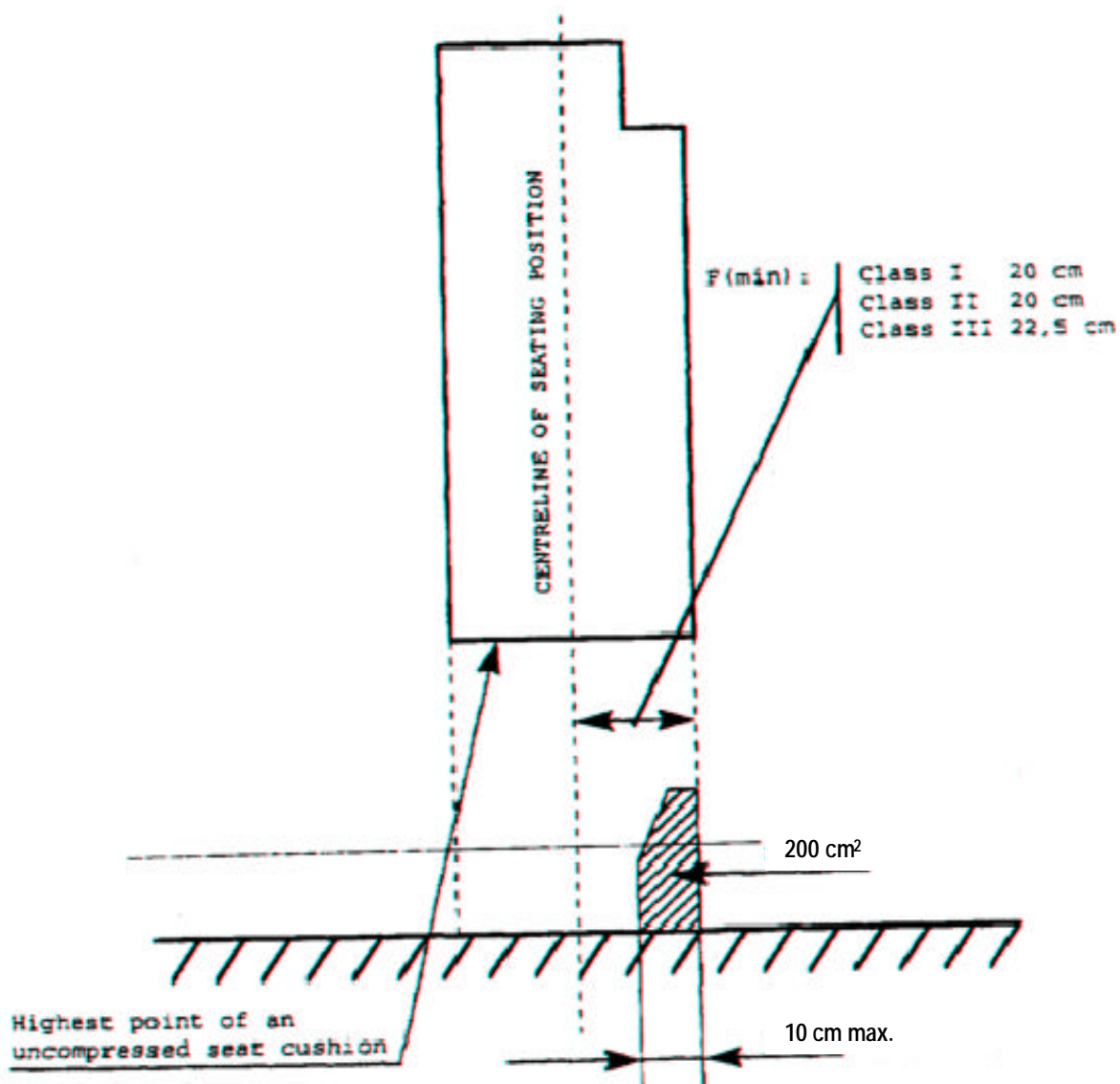
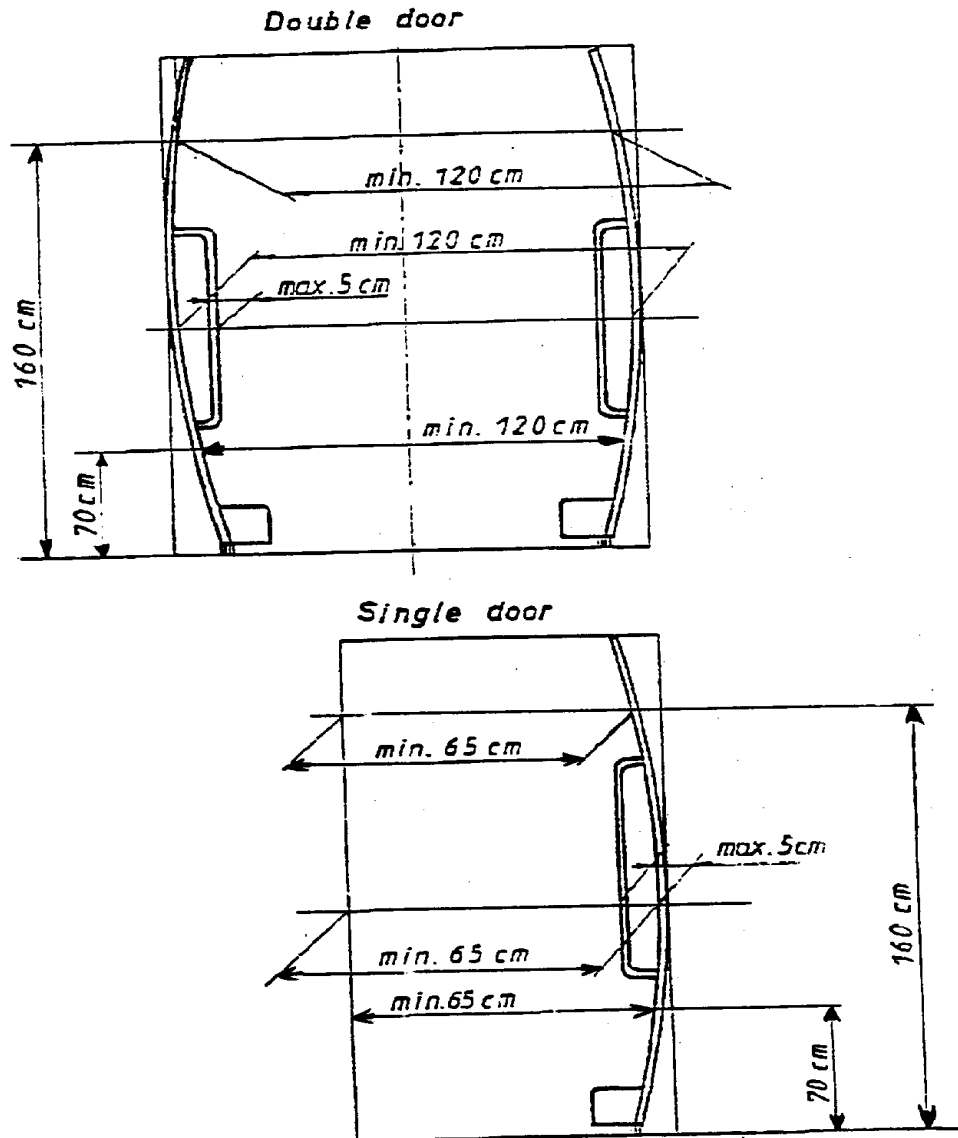

Figure 12

SERVICE DOOR FREE ACCESS
(see paragraph 5.6.3.1.)



Annex 4

MANOEUVRABILITY
(see paragraph 5.10.)

Figure A

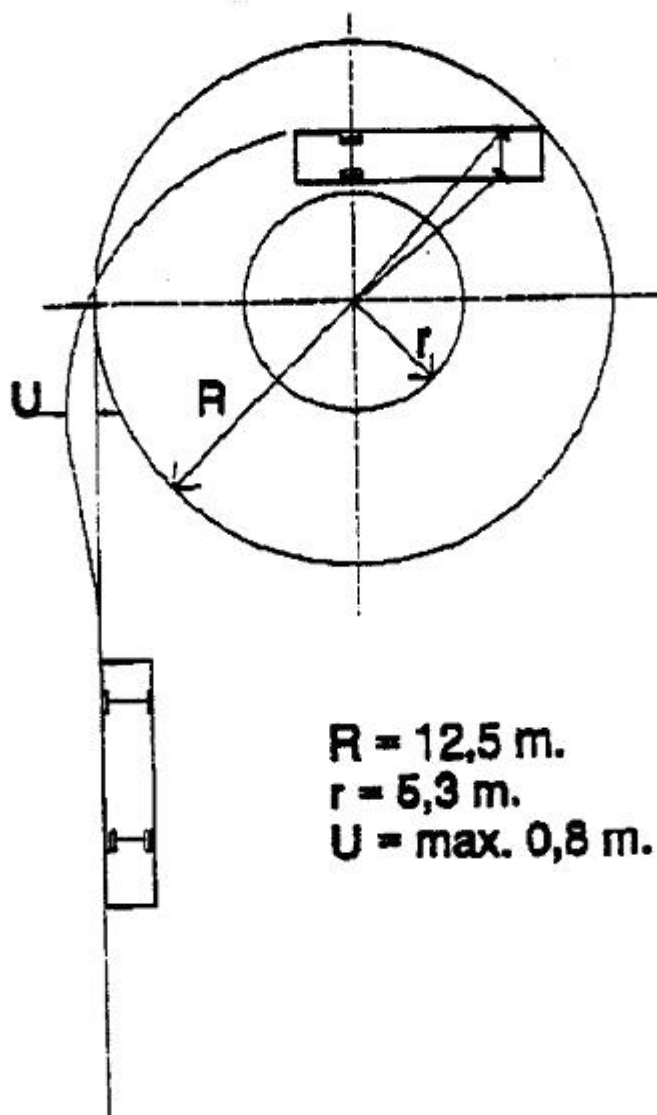
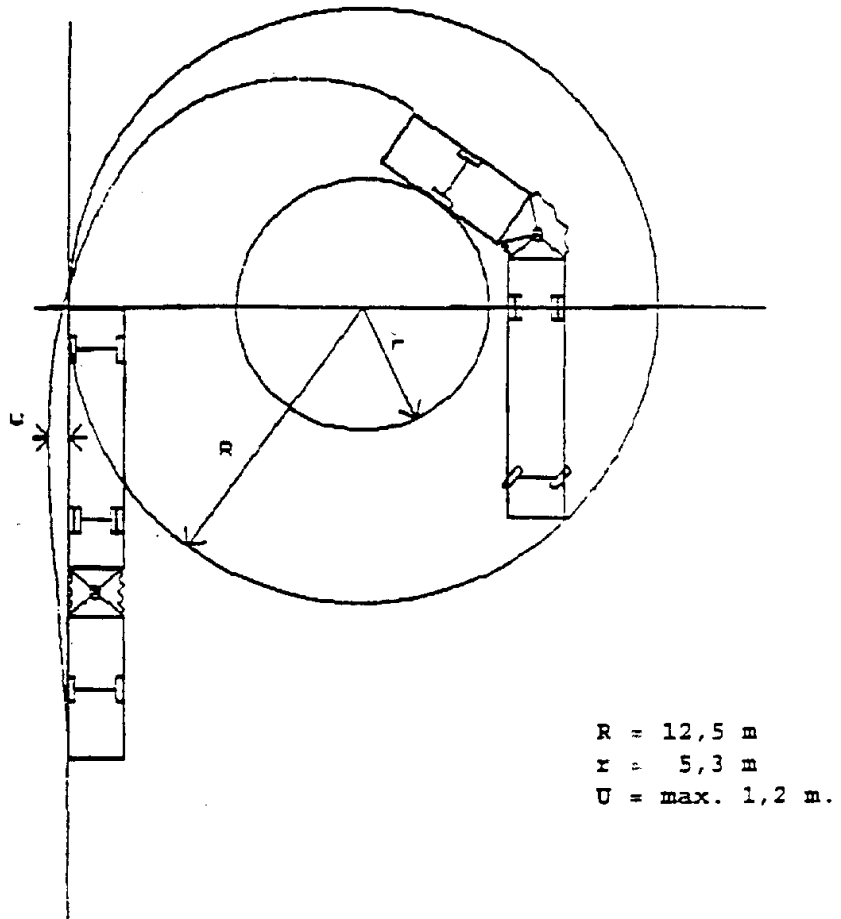
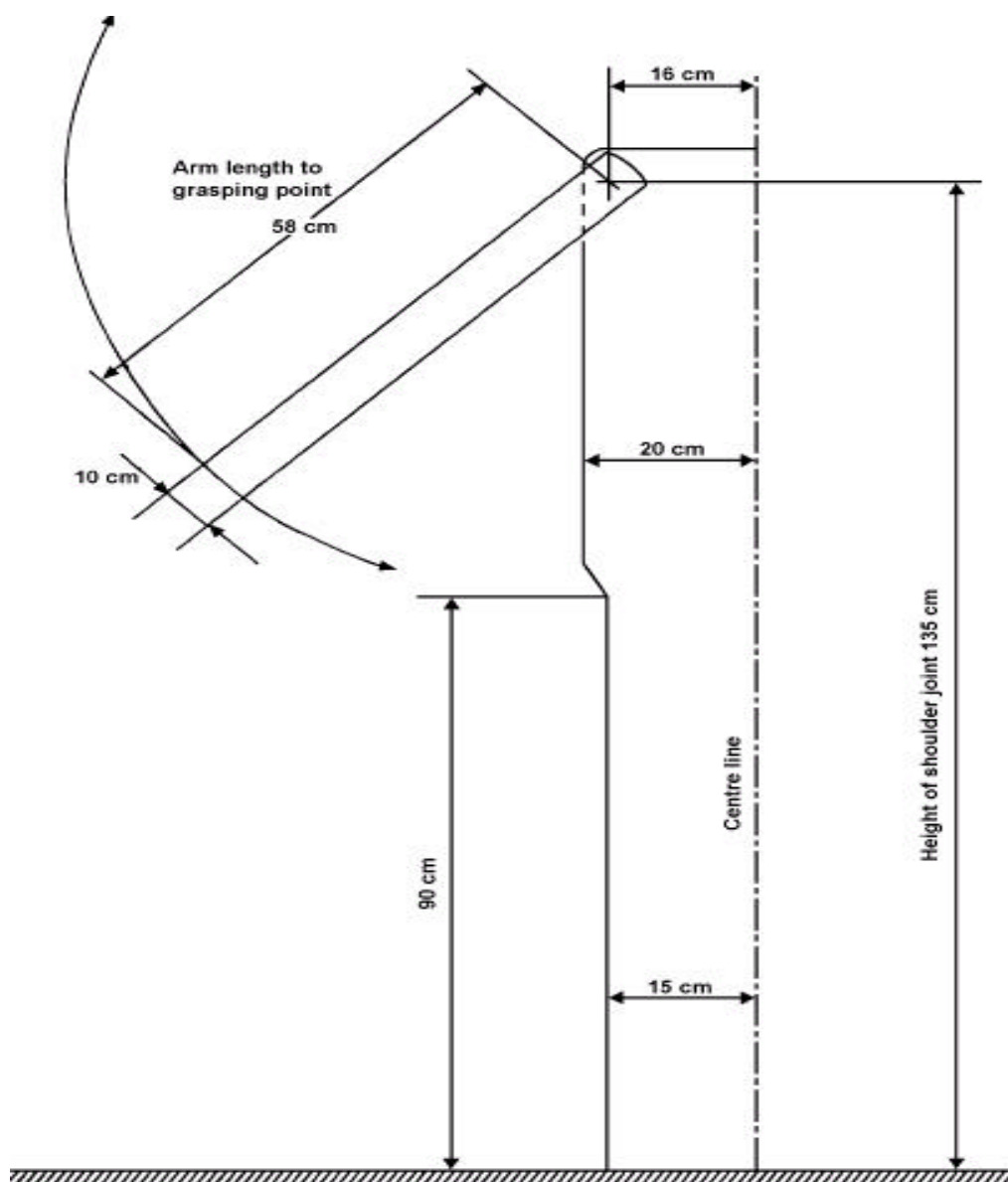

Figure B



Annex 5

TESTING DEVICE FOR SITING OF HAND-RAILS AND HAND-HOLDS
(see paragraph 5.12.2.1.)



Thickness: 2 cm.

Annex 6

(see paragraph 5.6.5.6.2.)

GUIDELINES FOR MEASURING THE CLOSING FORCES
OF POWER-OPERATED DOORS

1. General

The closing of a power-operated door is a dynamic process. When a moving door hits an obstacle, the result is a dynamic reaction force, the history of which (in time) depends on several factors (e.g. mass of the door, acceleration, dimensions).

2. Definitions

2.1. Closing force $F(t)$ is a time function, measured at the closing edges of the door (see paragraph 3.2.).

2.2. Peak force F_S is the maximum value of the closing force.

2.3. Effective force F_E is the average value of the closing force related to the pulse duration:

$$F_E = \frac{1}{T} \int_{t_1}^{t_2} F(t) dt$$

2.4. Pulse duration T is the time between the t_1 and t_2 :

$$T = t_2 - t_1$$

where t_1 = threshold of sensitivity, where the closing force exceeds 50 N.

t_2 = fade-away threshold, where the closing force becomes less than 50 N.

2.5. The relation between the above parameters is shown in figure 1 below (as an example):

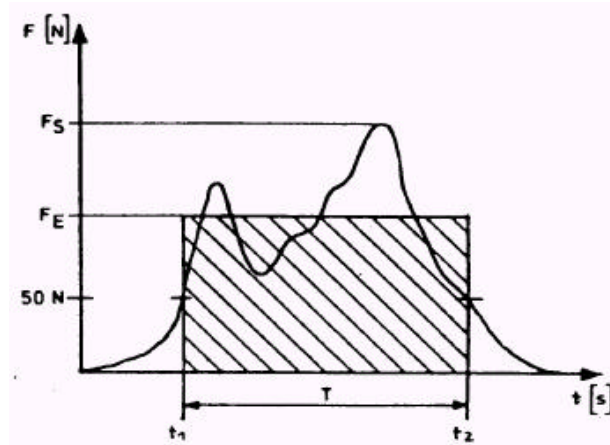

Figure 1

- 2.6 Clamping force F_c is the arithmetical mean value of the effective forces, measured at the same measuring point subsequently more times:

$$F_c = \frac{\sum_{i=1}^n (F_E)_i}{n}$$

3. Measurements

3.1. Conditions of measurement:

3.1.1. Temperature range: 10° - 30 °C

3.1.2. The vehicle shall stay on a horizontal surface.

3.2. Measurements points shall be:

3.2.1. At the main closing edges of the door:

- (i) one in the middle of the door;
- (ii) one 150 mm above the lower edge of the door.

3.2.2. In the case of doors equipped with clamping prevention devices for the opening process:

At the secondary closing edges of the door at that point which is considered to be the most dangerous place of clamping.

- 3.3. At least three measurements shall be taken at each of the measuring points to determine the clamping force according to paragraph 2.6. above.
- 3.4. The signal of the closing force shall be recorded by means of a low-pass filter with a limiting frequency of 100 Hz. Both the threshold of sensitivity and the fade-away threshold to limit the pulse duration shall be set at 50 N.
- 3.5. The deviation of the reading from the rated value shall not be more than " 3 per cent.
4. Measuring device
- 4.1. The measuring device shall consist of two parts: one handle and one measuring part which is a load cell (see figure 2).
- 4.2. The load cell shall have the following characteristics:
- 4.2.1. It shall consist of two sliding housings with the outer dimension of 100 mm in diameter and 115 mm in width. Inside the load cell a compression spring shall be fitted between the two housings such that the load cell can be pressed together if an appropriate force is applied.
- 4.2.2. The stiffness of the load cell shall be 10 " 0.2 N/mm. The maximum spring deflection shall be limited to 30 mm so that a maximum peak force of 300 N is achieved.

Figure 2

