

Distr.
GENERAL

TRANS/WP.29/GRSG/1999/22/Rev.1
29 July 2002

Original: ENGLISH

ECONOMIC COMMISSION FOR EUROPE

INLAND TRANSPORT COMMITTEE

World Forum for Harmonization of Vehicle Regulations (WP.29)

Working Party on General Safety Provisions (GRSG)

(Eighty-third session, 15-18 October 2002,
agenda item 3.)

PROPOSAL FOR DRAFT AMENDMENTS TO REGULATION No. 107
(Double-deck large passenger vehicles)

Revision 1

Transmitted by the Expert from the United Kingdom

Note: The text reproduced below was prepared by the expert from the United Kingdom in order to incorporate into the Regulation technical provisions for the carriage of passengers of reduced mobility and wheelchair users. It reproduces the text of Annex 7 of European Union Directive 2001/85/EC together with the necessary clauses to link it to Regulation No. 36. (TRANS/WP.29/GRSG/60, paras. 5 and 14). It is based on the text of a document distributed without a symbol (informal document No. 8) distributed during the eighty-second session (TRANS/WP.29/GRSG/61, para. 4). The amendments to documents TRANS/WP.29/GRSG/1999/22 and Add.1 are marked in bold.

Note: This document is distributed to the Experts on General Safety Provisions only.

GE.02-23180

List of contents,

Insert a new heading, to read:

"**Annex 8** Requirements for technical devices facilitating access for people with reduced mobility"

Text of Regulation,

Paragraph 2.19.1., amend to read:

"2.19.1. "passenger with reduced mobility" means all passengers who have a difficulty when using public transport, such as disabled people (including people with sensory and intellectual impairments, and wheelchair users), people with limb impairments, people of small stature, people with heavy luggage, elderly people, pregnant women, people with shopping trolleys, and people with children (including children seated in pushchairs)".

Insert new paragraphs 2.30 to 2.39., to read:

- "2.30. "wheelchair user" means a person who due to infirmity or disability uses a wheelchair for mobility.
- 2.31. "member of the crew" means a person assigned to operate as a co-driver or the possible assistant.
- 2.32. "priority seat" means a seat with additional space for a passenger with reduced mobility and marked accordingly.
- 2.33. "boarding device" means a device to facilitate wheelchair access to vehicles, such as lifts, ramps, etc.
- 2.34. "kneeling system" means a system which lowers and lifts totally or partially the body of a vehicle relative to the normal position of travel.
- 2.35. "lift" means a device or system with a platform that can be raised and lowered to provide passenger access between the floor of a passenger compartment and the ground or kerb.
- 2.36. "ramp" means a device to bridge the gap between the floor of a passenger compartment and the ground or kerb.
- 2.37. "portable ramp" means a ramp that may be detached from the vehicle structure and capable of being deployed by a driver or crew member.
- 2.38. "demountable seat" means a seat that can be easily detached from the vehicle.
- 2.39. "front" and "rear" means the front or rear of the vehicle according to the normal direction of travel and the terms; "forward", "foremost", "rearward" and "rearmost" etc. shall be construed accordingly."

Insert new paragraphs 5.16. and 5.16.1, to read:

"5.16. Special provisions for passengers with reduced mobility.

5.16.1. All vehicles of Class I, and those vehicles of other Classes which are specially equipped for the carriage of passengers with reduced mobility, shall additionally comply with the provisions set out in annex 9 to this Regulation."

Annex 1,

Insert new items 12.1. and 12.2., to read:

"12.1. Vehicle complies with annex 7 on accessibility Yes/No ..1/"

12.2.	Boarding Aid	Ramp	Manual/Powered	<u>1</u> /
		Lift	Manual/Powered	<u>1</u> /
		Kneeling	Fitted/Not fitted	<u>1</u> /"

Annex 3,

Insert new figures 17 to 19b, to read:

"Figure 17

REFERENCE WHEELCHAIR

(see annex 8, paragraph 3.6.4.)

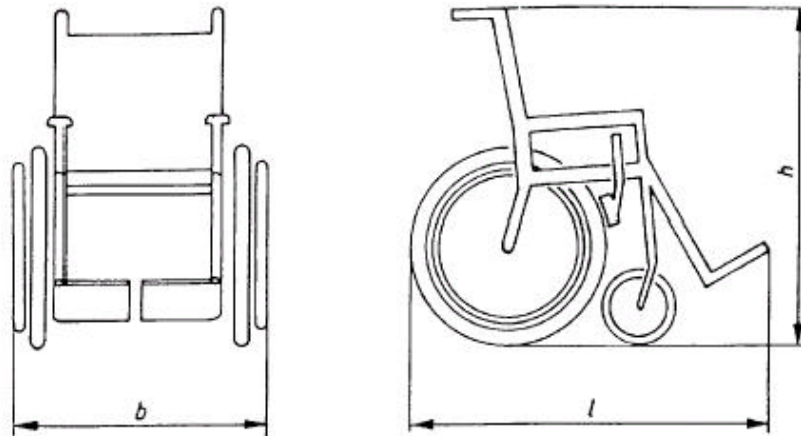

Overall length, l: 120 cm

Overall width, b: 70 cm

Overall height, h: 109 cm

Note:

A wheelchair user seated in the wheelchair adds 5 cm to the overall length and makes a height of 135 cm above the ground.

Figure 18

Minimum clear space for the wheelchair user at the wheelchair space

(see annex 8, paragraph 3.6.1.)

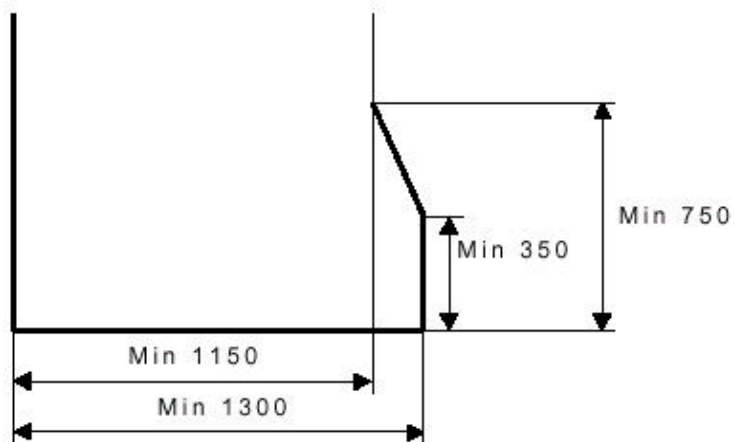

(Note: Diagram as shown above but with units in cm)

Figure 19

(see annex 8, paragraph 3.4.)

Pictogram for wheelchair users (Fig. 19a)



Pictogram for passengers with reduced mobility others than wheelchair users
(Fig. 19b)



Insert a new annex 8, to read:

"Annex 8
(see paragraph 5.16.)

REQUIREMENTS FOR TECHNICAL DEVICES FACILITATING ACCESS
FOR PASSENGERS OF REDUCED MOBILITY

1. GENERAL

This annex contains the provisions which apply to a vehicle designed for easy access for passengers with reduced mobility and wheelchair users.

2. SCOPE

These requirements shall apply to vehicles permitting easier access for persons with reduced mobility.

3. REQUIREMENTS.

3.1. Steps

3.1.1 The height of the first step from the ground of at least one service door shall not exceed **25 cm** for vehicles of Class I and **32 cm** for vehicles of Class II and III.

As an alternative for vehicles of **Class I**, the first step from the ground shall not exceed **27 cm** in two door openings, one entrance and one exit.

A kneeling system and/or retractable step may be engaged.

3.1.2. The height of the steps other than the first step from the ground at the above-mentioned door(s), in an access passage and in a gangway, shall be not more than **20 cm** for vehicles of **Class I** and **25 cm** for vehicles of **Class II** and **III**.

3.1.3. The transition from a sunken gangway to a seating area shall not be considered to be a step.

3.2. Priority seats and space for passengers with reduced mobility

3.2.1. A minimum number of forward or rearward facing seats designated as priority seats for disabled passengers shall be situated in a position near to a service door(s) suitable for boarding and alighting. The minimum number of priority seats shall be four in Class **I** and two in Class II and Class **III**. A seat that folds out of the way when not in use shall not be designated as a priority seat. Paragraph 5.7.8.5.2. **of this Regulation** shall not apply to vehicles that comply with this requirement.

3.2.2. There shall be adequate space under, or adjacent to, at least one of the priority seats for a guide dog.

3.2.3. Armrests shall be fitted on seats between the seating position and the gangway and shall be capable of being moved easily out of the way to permit clear access to the seat.

Handrails or handholds shall be fitted adjacent to priority seats in such a way as to allow the passenger to grasp them easily.

3.2.4. The minimum width of a priority seat cushion, measured from a vertical plane passing through the centre of that seating position, shall be **22 cm** on each side or, in the case of a continuous seat, **22 cm** per seating position on each side.

3.2.5. The height of the uncompressed seat cushion relative to the floor shall be such that the distance from the floor to a horizontal plane tangent to the front upper surface of the seat cushion is between **40 and 50 cm**.

3.2.6. The foot space at priority seating positions shall extend forward of the seat from a vertical plane through the forward edge of the seat cushion. The foot space shall not have a slope in any direction of more than 8 per cent.

3.2.7. Each priority seating position shall have a free height of not less than **130 cm** for vehicles of Class I and **90 cm** for vehicles of Class II, measured from the highest point of the uncompressed seat cushion. This free height shall extend over the vertical projection of the whole of the seat and the associated foot space. Intrusion of a seat back or other object into this space shall be permitted provided that a minimum clear vertical space extending **23 cm** in front of the seat cushion is maintained. Where the priority seat is positioned facing a bulkhead more than **120 cm** in height this space shall be **30 cm**.

3.3. Communication devices

3.3.1. Communication devices shall be placed adjacent to any priority seat and within any wheelchair area and shall be at a height between **70 cm and 120 cm** above the floor.

3.3.2. Communication devices situated in the low floor area shall be at a height between **80 cm and 150 cm** where there are no seats.

3.3.3. The control for all internal communication devices shall be capable of operation with the palm of the hand and shall be in a contrasting colour or colours and tone.

- 3.3.4. If a vehicle is fitted with a ramp or lift, a means of communication with the driver shall be fitted outside, adjacent to the door, and not higher than **130 cm** from the ground.
- 3.4. Pictograms
- 3.4.1. Vehicles fitted with a wheelchair space **and/or** priority seats shall have **pictograms** in accordance with **annex 3, figure 15(a)** visible from the outside, both on the front nearside of the vehicle and adjacent to the relevant service door(s). Appropriate pictograms will also be placed internally adjacent to the wheelchair space or to **the priority seat**.
- 3.5. Floor slope
- The slope of any gangway, access passage or floor area between any priority seat or wheelchair space and at least one entrance and one exit or a combined entrance and exit shall not exceed 8 per cent. **Such sloping areas shall be provided with a non-slip surface.**
- 3.6. Wheelchair accommodation provisions
- 3.6.1. For each wheelchair user provided for in the passenger compartment there shall be a special area at least **75 cm wide and 130 cm** long. The longitudinal plane of the special area shall be parallel to the longitudinal plane of the vehicle and the floor surface of the special area shall be slip resistant.
- In the case of a wheelchair space designed for a forward facing wheelchair, the top of preceding seat-backs may intrude into the wheelchair space if a clear space is provided as shown in annex 3, figure **18**.
- 3.6.2. There shall be at least one doorway through which wheelchair users can pass. In the case of vehicles of Class I, at least one wheelchair access door shall be a service door. The wheelchair access door shall bear a boarding aid complying with the provisions of paragraph 3.11.2 (**a kneeling system**) of this annex; **this shall be in combination with the provisions of paragraph 3.11.3. (a lift) or 3.11.4. (a ramp) of this annex.**
- 3.6.3. A door for wheelchair access, that is not a service door, shall have a minimum height of **140 cm**. The minimum width of all doors providing wheelchair access to the vehicle shall be **90 cm** which may be reduced by **10 cm** when the measurement is made at the level of handholds.
- 3.6.4. It shall be possible to move from the outside of the vehicle through at least one of the doors for wheelchair access into the special area(s) with a reference wheelchair of the dimensions shown in annex 3, figure **17**.
- 3.7. Seats in the wheelchair space
- 3.7.1. Folding seats may be fitted in a wheelchair space. However, such seats when folded and out of use shall not intrude into the wheelchair space.

- 3.7.2. A vehicle may be equipped with demountable seats fitted in the wheelchair space provided that such seats may be easily removed by the driver or a crew member.
- 3.7.3. Where the foot space of any seat, or part of a folding seat when in use, intrudes into a wheelchair space, those seats shall have a sign fixed on or adjacent to them with the following text:

"Please give up this space for a wheelchair user".

3.8. Stability of wheelchairs

- 3.8.1. Wheelchair restraint system. As an alternative to the requirements contained in paragraphs 3.8.1.1. to 3.8.1.2.3. restraint systems may comply with the requirements contained in paragraphs 3.8.2. to 3.8.2.11.

- 3.8.1.1. In a vehicle where passenger seats are not required **to be fitted** with any kind of occupant restraint system, the wheelchair space shall be fitted with a restraint system in order to warrant the stability of the wheelchair;

A static test shall be carried out in accordance with the following requirements:

- (a) a force of $250 \text{ daN} \pm 20 \text{ daN}$ per wheelchair shall be applied on the restraint system itself;
- (b) the force shall be applied in the horizontal plane of the vehicle and towards the front of the vehicle if the restraint system is not attached to the floor of the vehicle. If the restraint system is attached to the floor, the force shall be applied in an angle of $45^\circ \pm 10^\circ$ to the horizontal plane and towards the front of the vehicle;
- (c) the force shall be maintained for a period of not less than 1.5 seconds;
- (d) the restraint system shall be capable of withstanding the test. Permanent deformation, including partial rupture or breakage of the restraint system, shall not constitute failure if the required force is sustained for the specified time. Where applicable, the locking device enabling the wheelchair to leave the vehicle shall be operable by hand after removal of the traction force.

- 3.8.1.2. When passenger seats are required **to be fitted** with occupant restraint systems, each wheelchair space shall be provided with a restraint system capable of restraining the wheelchair and its occupant.

This restraint system and its **anchorages** shall be designed to withstand forces equivalent to the ones required for the passenger seats and occupant restraint systems.

A static test shall be carried out in accordance with the following requirements:

- (a) the forces referred hereto shall be applied in forward and rearward **directions**, separately and on the restraint system itself;
- (b) the force shall be maintained for a period of not less than 0.2 seconds
- (c) the restraint system shall be capable of withstanding the test. Permanent deformation, including partial rupture or breakage of the restraint system shall not constitute failure if the required force is sustained for the specified time. Where applicable, the locking device enabling the wheelchair to leave the vehicle shall be operable by hand after **removal of the traction force**.

3.8.1.2.1. In forward direction in the case of a separate wheelchair and wheelchair user restraint system

3.8.1.2.1.1. For category M2

- (a) 1,110 daN \pm 20 daN in the case of a lap belt. The force shall be applied on the wheelchair user restraint system in the horizontal plane of the vehicle and towards the front of the vehicle if the restraint system is not attached to the floor of the vehicle. If the restraint system is attached to the floor, the force shall be applied in an angle of $45^\circ \pm 10^\circ$ to the horizontal plane of the vehicle and towards the front of the vehicle;
- (b) 675 daN \pm 20 daN in the horizontal plane of the vehicle and towards the front of the vehicle on the lap portion of the belt and 675 daN \pm 20 daN in the horizontal plane of the vehicle and towards the front of the vehicle on the torso portion of the belt in the case of 3-point belt;
- (c) 1,715 daN \pm 20 daN in an angle of $45^\circ \pm 10^\circ$ to the horizontal plane of the vehicle and towards the front of the vehicle on the wheelchair restraint system;
- (d) the forces shall be applied simultaneously.

3.8.1.2.1.2. For category M3:

- (a) 740 daN \pm 20 daN in the case of a lap belt. The force shall be applied on the wheelchair user restraint system in the horizontal plane of the vehicle and towards the front of the vehicle if the restraint system is not attached to the floor of the vehicle. If the restraint system is attached to the floor, the force shall be applied in an angle $45^\circ \pm 10^\circ$ to the horizontal plane of the vehicle and towards the front of the vehicle;
- (b) 450 daN \pm 20 daN in the horizontal plane of the vehicle and towards the front of the vehicle on the lap portion of the belt and 450 daN \pm 20 daN in the horizontal plane of the vehicle and towards the front of the vehicle on the torso portion of the belt in the case of 3-point belt;

(c) 1,130 daN \pm 20 daN in an angle of $45^\circ \pm 10^\circ$ to the horizontal plane of the vehicle and towards the front of the vehicle on the wheelchair restraint system;

(d) the forces shall be applied simultaneously.

3.8.1.2.2. In forward direction in the case of a combined wheelchair and wheelchair user restraint system.

3.8.1.2.2.1. For category M2;

(a) 1,110 daN \pm 20 daN in an angle of $45^\circ \pm 10^\circ$ to the horizontal plane of the vehicle and towards the front of the vehicle on the wheelchair user restraint system in the case of a lap belt;

(b) 675 daN \pm 20 daN in an angle of $45^\circ \pm 10^\circ$ to the horizontal plane of the vehicle and towards the front of the vehicle on the lap portion of the belt and 675 daN \pm 20 daN in the horizontal plane of the vehicle and towards the front of the vehicle on the torso portion of the belt in the case of 3-point belt;

(c) 1,715 daN \pm 20 daN in an angle of $45^\circ \pm 10^\circ$ to the horizontal plane of the vehicle and towards the front of the vehicle on the wheelchair restraint system;

(d) the forces shall be applied simultaneously.

3.8.1.2.2.2. For category M3:

(a) 740 daN \pm 20 daN in an angle of $45^\circ \pm 10^\circ$ to the horizontal plane of the vehicle and towards the front of the vehicle on the wheelchair user restraint system in the case of a lap belt;

(b) 450 daN \pm 20 daN in an angle of $45^\circ \pm 10^\circ$ to the horizontal plane of the vehicle and towards the front of the vehicle on the lap portion of the belt and 450 daN \pm 20 daN in the horizontal plane of the vehicle and towards the front of the vehicle on the torso portion of the belt in the case of 3-point belt;

(c) 1,130 daN \pm 20 daN in an angle of $45^\circ \pm 10^\circ$ to the horizontal plane of the vehicle and towards the front of the vehicle on the wheelchair restraint system;

(d) the forces shall be applied simultaneously.

3.8.1.2.3. In rearward direction:

(a) 810 daN \pm 20 daN in an angle of $45^\circ \pm 10^\circ$ to the horizontal plane of the vehicle and towards the rear of the vehicle on the wheelchair restraint system.

3.8.2. Alternative wheelchair restraint system:

- 3.8.2.1. a wheelchair space shall be fitted with a wheelchair restraint system suitable for general wheelchair application and shall allow the carriage of a wheelchair and a wheelchair user facing the front of the vehicle;
- 3.8.2.2. a wheelchair space shall be fitted with a wheelchair user restraint system which shall comprise a minimum of two anchorage points and a pelvic restraint (lap belt) designed and constructed of components intended to perform in a similar manner to those of a **safety-belt** conforming to **Regulation No. 16**;
- 3.8.2.3. any restraint system fitted to a wheelchair space shall be capable of being easily released in the case of an emergency;
- 3.8.2.4 any wheelchair restraint system shall either:
 - 3.8.2.4.1. meet the dynamic test requirements described in paragraph 3.8.2.8. and be securely attached to vehicle anchorages meeting the static test requirements in paragraph 3.8.2.6.; or
 - 3.8.2.4.2. be securely attached to vehicle anchorages such that the combination of restraint and anchorages meets the requirements of paragraph 3.8.2.8.
- 3.8.2.5. any wheelchair user restraint shall either:
 - 3.8.2.5.1. meet the dynamic test requirements described in paragraph 3.8.2.9. and be securely attached to vehicle anchorages meeting the static test requirements in paragraph 3.8.2.6.; or
 - 3.8.2.5.2. be securely attached to vehicle anchorages such that the combination of restraint and anchorages meets the dynamic test requirements described in paragraph 3.8.2.9. when attached to anchorages set up as described in paragraph 3.8.2.6.7.
- 3.8.2.6. A static test shall be carried out on the anchorage points for both the wheelchair restraint system and the wheelchair user restraint in accordance with the following requirements:
 - 3.8.2.6.1. the forces specified in paragraph 3.8.2.7. shall be applied by means of a device reproducing the geometry of the wheelchair restraint system;
 - 3.8.2.6.2. the forces specified in paragraph 3.8.2.7.3. shall be applied by means of a device reproducing the geometry of the wheelchair user restraint and by means of a traction device specified in **paragraph 5.3.4. of annex 1 to Regulation No. 14.**
 - 3.8.2.6.3. the forces in paragraphs 3.8.2.6.1. and 3.8.2.6.2. shall be applied simultaneously in the forward direction and at an angle of $10^{\circ} \pm 5^{\circ}$ above the horizontal plane;
 - 3.8.2.6.4. the forces in paragraph 3.8.2.6.1. shall be applied in the rearward direction and at an angle of $10^{\circ} \pm 5^{\circ}$ above the horizontal plane;
 - 3.8.2.6.5. the forces shall be applied as rapidly as possible through the central vertical axis of the wheelchair space; and

- 3.8.2.6.6. the forces shall be maintained for a period of not less than 0.2 seconds.
- 3.8.2.6.7. the test shall be carried out on a representative section of the vehicle structure together with any fitting provided in the vehicle which is likely to contribute to the strength or rigidity of the structure.
- 3.8.2.7. The forces specified in paragraph 3.8.2.6. are:
 - 3.8.2.7.1. in the case of anchorages provided for a wheelchair restraint system fitted to a category M2 vehicle:
 - 3.8.2.7.1.1. 1,110 daN applied in the longitudinal plane of the vehicle and towards the front of the vehicle at a height of not less than **20 cm** and not more than **30 cm** measured vertically from the floor of the wheelchair space, and
 - 3.8.2.7.1.2. 550 daN applied in the longitudinal plane of the vehicle and towards the rear of the vehicle at a height of not less than **20 cm** and not more than **30 cm** measured vertically from the floor of the wheelchair space;
 - 3.8.2.7.2. in the case of anchorages provided for a wheelchair restraint system fitted to a Category M3 vehicle:
 - 3.8.2.7.2.1. 740 daN applied in the longitudinal plane of the vehicle and towards the front of the vehicle at a height of not less than **20 cm** and not more than **30 cm** measured vertically from the floor of the wheelchair space, and
 - 3.8.2.7.2.2. 370 daN applied in the longitudinal plane of the vehicle and towards the rear of the vehicle at a height of not less than **20 cm** and not more than **30 cm** measured vertically from the floor of the wheelchair space;
 - 3.8.2.7.3. in the case of anchorages provided for a wheelchair user restraint system the forces shall be in accordance with the requirements of paragraph **5.4.** of Annex 1 to Regulation No. 14.
- 3.8.2.8. A wheelchair restraint system shall be subject to a dynamic test carried out in accordance with the following requirements:
 - 3.8.2.8.1. a representative wheelchair test trolley of mass 85 kg shall, from a speed of between 48 km/h to 50 km/h to rest, be subject to a deceleration-time pulse:
 - 3.8.2.8.1.1. exceeding 20 g in the forward direction for a cumulative period of at least 0.015 seconds;
 - 3.8.2.8.1.2. exceeding 15 g in the forward direction for a cumulative period of at least 0.04 seconds;
 - 3.8.2.8.1.3. exceeding a duration of 0.075 seconds;
 - 3.8.2.8.1.4. not exceeding 28 g and for not more than 0.08 seconds;
 - 3.8.2.8.1.5. not exceeding a duration of more than 0.12 seconds, and

- 3.8.2.8.2. a representative wheelchair test trolley of mass 85 kg shall, from a speed of between 48 km/h to 50 km/h to rest, be subject to a deceleration-time pulse:
 - 3.8.2.8.2.1. exceeding 5 g in the rearward direction for a cumulative period of at least 0.015 seconds;
 - 3.8.2.8.2.2. not exceeding 8 g in the rearward direction and for not more than 0.02 seconds;
- 3.8.2.8.3. the test in paragraph 3.8.2.2. shall not apply if the same restraints are used for the forward and rearward direction or if an equivalent test has been conducted;
- 3.8.2.8.4. for the above test, the wheelchair restraint system shall be attached to either:
 - 3.8.2.8.4.1. anchorages fixed to the test rig which represents the geometry of the anchorages in a vehicle for which the restraint system is intended, or
 - 3.8.2.8.4.2. anchorages forming part of a representative section of the vehicle for which the restraint system is intended, set up as described in paragraph 3.8.2.6.7.
- 3.8.2.9. A wheelchair occupant restraint shall comply with the test requirements specified in paragraph 2.7.8.4. of annex 1 to Regulation No. 16 or an equivalent test to the deceleration-time pulse in paragraph 3.8.2.8.1. A seat belt approved to Regulation No. 16, and so marked shall be deemed to comply.
- 3.8.2.10. A test in paragraph 3.8.2.6., 3.8.2.8. or 3.8.2.9. shall be deemed to have failed unless the following requirements are met:
 - 3.8.2.10.1. no part of the system shall have failed, or shall have become detached from its anchorage or from the vehicle during the test;
 - 3.8.2.10.2. mechanisms to release the wheelchair and user shall be capable of release after completion of the test;
 - 3.8.2.10.3. in the test in paragraph 3.8.2.8. the wheelchair shall not move more than 20 cm in the longitudinal plane of the vehicle during the test;
 - 3.8.2.10.4. no part of the system shall be deformed to such an extent after completion of the test that, because of sharp edges or other protrusions, the part is capable of causing injury.
- 3.8.2.11 Its operating instructions shall be clearly displayed adjacent to it.
- 3.8.3. **As an** alternative to the provisions of paragraph 3.8.1.1., the wheelchair space shall be designed for the wheelchair user to travel unrestrained with the wheelchair facing rearwards against a support or backrest, in accordance with the following provisions:
 - 3.8.3.1. one of the longitudinal sides of the space for a wheelchair shall rest against a side or wall of the vehicle;

- 3.8.3.2. a support or backrest perpendicular to the longitudinal axis of the vehicle shall be provided in the forward end of the wheelchair space;
- 3.8.3.3. the support of backrest shall be designed for the wheels or the back of the wheelchair to rest against the support or backrest in order to avoid the wheelchair from tipping over;
- 3.8.3.4. the support or backrest of the seat row in front shall be able to withstand a force of $250 \text{ daN} \pm 20 \text{ daN}$ per wheelchair. The force shall be applied in the horizontal plane of the vehicle and towards the front of the vehicle in the middle of the support or backrest. The force shall be maintained for a period of not less than 1.5 seconds;
- 3.8.3.5. a handrail or handhold shall be fitted to the side or wall of the vehicle in such a way to allow the wheelchair user to grasp it easily;
- 3.8.3.6. a retractable handrail or any equivalent device shall be fitted on the opposite side of the wheelchair space in order to restrict any lateral shift of the wheelchair and to allow the wheelchair user to grasp it easily;
- 3.8.3.7. the floor surface of the special area shall be slip-resistant;
- 3.8.3.8. a sign shall be fixed adjacent to the wheelchair area with the following text:

"This space is reserved for a wheelchair. The wheelchair must be placed facing rearwards resting against the support or backrest with the brakes on".

3.9. Door controls

- 3.9.1. Any opening control adjacent to a door referred to in paragraph 3.6., whether being outside or inside of the vehicle, shall not be higher than **130 cm** from the ground or the floor.

3.10. Lighting

- 3.10.1. Adequate lighting shall be provided to illuminate the area inside and immediately outside the vehicle to allow people with reduced mobility to board and alight in safety. Any lighting likely to affect the driver's vision shall operate only while the vehicle is at rest.

3.11. Provisions for boarding aids

3.11.1. General requirements:

- 3.11.1.1. The controls actuating the boarding aids shall be clearly marked as such. The extended or lowered position of the boarding aid shall be indicated by a **tell-tale** to the driver.
- 3.11.1.2. In the event of the failure of a safety device, lifts, ramps and kneeling systems shall be incapable of operation, unless they can be safely operated by manual effort. The type and location of the

emergency operating mechanism shall be clearly marked. In the event of power failure, lifts and ramps must be capable of manual operation.

3.11.1.3. Access to one of the service or emergency doors on the vehicle may be obstructed by a boarding aid providing the following two conditions are satisfied from both inside and outside the vehicle.

3.11.1.3.1. The boarding device does not obstruct the handle or other device for opening the door.

3.11.1.3.2. The boarding device can be readily moved to leave the doorway clear for use in an emergency.

3.11.2. Kneeling system

3.11.2.1. A switch shall be required to enable operation of the kneeling system.

3.11.2.2. Any control which initiates the lowering or raising of any part or the whole of the bodywork relative to the road surface must be clearly identified and be under the direct control of the driver.

3.11.2.3. The lowering or raising process shall be capable of being stopped and immediately reversed by a control both within the reach of the driver, whilst seated in the cab, and also adjacent to any other operating controls provided for the operation of the kneeling system.

3.11.2.4. Any kneeling system, which is fitted to a vehicle shall not:

3.11.2.4.1. allow the vehicle to be driven at a speed of more than 5 km/h when the vehicle is lower than the normal height of travel, or

3.11.2.4.2. allow the vehicle to be raised or lowered when the operation of the service door is prevented for any reason.

3.11.3. Lift

3.11.3.1. General provisions

3.11.3.1.1. Lifts shall only be capable of operation when the vehicle is at a standstill. When raising of the platform and before lowering is initiated a device preventing the wheelchair from rolling off shall automatically come into operation.

3.11.3.1.2. The lift platform shall not be less than **80 cm** wide, and not less than **120 cm** long and shall be capable of operating when carrying a mass of at least 300 kg.

3.11.3.2.1. Additional technical requirements for power-operated lifts

3.11.3.2.1. The operating mechanism shall be designed in such a way that, if released, it automatically returns to the off position. As it does so the movement of the lift shall immediately be stopped and it shall be possible to initiate a movement in either direction.

3.11.3.2.2. A safety device (e.g. reversing mechanism) shall protect areas not visible to the operator, where the movement of the lift might trap or crush objects.

3.11.3.2.3. In the event of one of these safety devices coming into operation, the movement of the lift shall immediately be stopped and movement in the opposite direction initiated.

3.11.3.3.. Operation of power operated lifts

3.11.3.3.1. Where the lift is at a service door situated within the direct field of vision of the driver of the vehicle, the lift may be operated by the driver when in the driver's seat.

3.11.3.3.2. In all other cases, the controls shall be adjacent to the lift. They shall be capable of being activated and deactivated only by the driver from his seat.

3.11.3.4 Manually operated lift

3.11.3.4.1. The lift shall be designed for operation by controls adjacent to the lift.

3.11.3.4.2. The lift shall be so designed that excessive forces are not required to operate it.

3.11.4 Ramp

3.11.4.1. General provisions

3.11.4.1.1. The ramp shall only be capable of operation when the vehicle is at a standstill.

3.11.4.1.2. Edges on the outside shall be rounded to a radius of no less than 2.5 mm. Corners on the outside shall be rounded to a radius of not less than 5 mm.

3.11.4.1.3. The ramp shall be at least **80 cm** wide. The slope of the ramp, when extended or folded out on to a kerb of **15 cm** in height, should not exceed 12 per cent. A kneeling system may be used to achieve this test.

3.11.4.1.4. Any ramp which when ready for use exceeds **120 cm** in length shall be fitted with a device to prevent the wheelchair rolling off the sides.

3.11.4.1.5. Any ramp shall be capable of operating safely with a load of 300 kg.

3.11.4.2. Modes of operation

3.11.4.2.1. Extension and retraction of the ramp may be carried out either manually or power-operated.

3.11.4.3 Additional technical requirements for power-operated ramps

3.11.4.3.1. Extension and retraction of the ramp shall be indicated by flashing yellow lights and an audible signal; the ramps shall be identifiable by clearly visible red and white retro-reflecting hazard markings on the outer edges.

3.11.4.3.2. Extension of the ramp in the horizontal direction shall be protected by a safety device.

- 3.11.4.3.3. In the event of one of these safety devices coming into operation, the movement of the ramp shall immediately be stopped.
 - 3.11.4.3.4. The horizontal movement of a ramp shall be interrupted when it is loaded with a mass of 15 kg.
 - 3.11.4.4. Operation of power-operated ramps
 - 3.11.4.4.1. Where the ramp is at a service door situated within the direct field of vision of the driver of the vehicle, the ramp may be operated by the driver when in the driver's seat.
 - 3.11.4.4.2. In all others cases, the controls shall be adjacent to the ramp. They shall be capable of being activated and deactivated only by the driver from his seat.
 - 3.11.4.5. Operation of manually-operated ramp
 - 3.11.4.5.1. The ramp shall be so designed that excessive forces are not required to operate the ramp."
-