

Distr.  
GENERAL

TRANS/WP.29/GRSP/2001/14/Rev.1  
28 February 2002

Original: ENGLISH

ECONOMIC COMMISSION FOR EUROPE

INLAND TRANSPORT COMMITTEE

World Forum for Harmonization of Vehicle Regulations (WP.29)

Working Party on Passive Safety (GRSP)  
(Thirty-first session, 13-17 May 2002,  
agenda item 2.)

PROPOSAL FOR DRAFT 06 SERIES OF AMENDMENT TO REGULATION No. 14  
(Safety-belt anchorage)

Revision 1

Transmitted by the Expert from France

Note: The text reproduced below was prepared by the expert from France in order to introduce into Regulation No. 14 the new anchorage system standard for child restraint systems (CRS) prepared by the International Organisation for Standardisation (ISO). It based on a document distributed without a symbol (informal document No. 13) during the thirtieth session (TRANS/WP.29/GRSP/30, para. 45).

The text is presented as follows:

- (1) "ISOFIX" is used as a qualified adjective in order to simplify the modification redaction and to allow child restraint system users to be able to identify ISOFIX restraints without any doubt,
- (2) word added to the original text of Regulation No. 14 are written in **bold type**,
- (3) words removed from the original text of Regulation No. 14 are written in **bold type** between bracket and crossed out,
- (3) words added (or removed) to document TRANS/WP.29/GRSP/2001/14 are underlined (or crossed out).

---

Note: This document is distributed to the Experts on Passive Safety only.

GE.02-20788

The title of the Regulation, amend to read:

"UNIFORM PROVISIONS CONCERNING THE APPROVAL OF VEHICLES WITH REGARD TO SAFETY-BELT ANCHORAGE, ISOFIX ANCHORAGES SYSTEMS AND ISOFIX TOP TETHER ANCHORAGE. ~~AND THE APPROVAL OF AFTERMARKET ISOFIX LOW ANCHORAGES.~~"

Paragraph 1., amend to read:

"..... of categories M and N1/.

It also applies to ISOFIX anchorages systems and ISOFIX top tether anchorage intended to ISOFIX child restraint systems installed in vehicle of category M1 and N1. ~~and aftermarket ISOFIX low anchorages.~~"

Paragraph 2.2., amend to read:

" .....to which the safety belts anchorages and the ISOFIX anchorages systems and ISOFIX top tether anchorage if any are attached ..."

Insert new paragraphs 2.17. to 2.26., to read:

- 2.17.            "ISOFIX position" means a system which allows to install either:  
                  -an universal ISOFIX forward facing child restraint system as defined in Regulation No. 44 (i.e. using an ISOFIX anchorages system and an ISOFIX top tether anchorage),  
                  -or a semi-universal, or a specific, ISOFIX forward facing child restraint system as defined in Regulation No. 44 (i.e. using an ISOFIX anchorage system and other(s) anti-rotation device(s),  
                  -or a semi-universal, or a specific, ISOFIX rearward facing child restraint system as defined in Regulation No. 44 (i.e. using an ISOFIX anchorage system and other(s) anti-rotation device(s).
- 2.18.            "ISOFIX low anchorage" means one 6 mm diameter rigid round horizontal bar, extending from vehicle or seat structure to accept and restraint an ISOFIX child restraint system with ISOFIX attachments.
- 2.19.            "ISOFIX anchorages systems" means a system made of two ISOFIX low anchorages which is designed for attaching an ISOFIX child restraint system.  
                  The rotation of the ISOFIX child restraint system must be limited.
- 2.20.            "ISOFIX attachment" means one of the two connections, fulfilling the requirements of Regulation No. 44, extending from the ISOFIX child restraint system structure, and compatible with an ISOFIX low anchorage.
- 2.21.            "ISOFIX child restraint system" means a child restraint system which has to be attached to an ISOFIX anchorages system and ISOFIX top tether anchorage if needed.
- 2.22.            "Static force application device (S-FAD)" means a test fixture that engages the vehicle ISOFIX anchorages systems and that is used to verify their strength and the ability of the vehicle or seat structure to limit the rotation in a static test. The test fixture is describe in the figures 1 and 2.  
  
The S-FAD is made of steel, mild steel rectangular tubing 50 mm by 75 mm of 3 mm nominal thickness, with 6 mm thick force application test device attachment point plate. Securely welded construction.

- 2.23.           "ISOFIX top tether anchorage" means a feature, such as a bar, located in a defined zone, designed to accept an ISOFIX tether strap connector and transfer its restraint forces to the vehicle structure
- 2.24.           "ISOFIX top tether connector" means a device intended to attach to an ISOFIX top tether anchorage.
- 2.25.           "ISOFIX top tether hook" means a top tether connector typically used to attach a top tether strap to a top tether anchorage as defined in figure 3.
- 2.26.           "ISOFIX top tether strap" means a webbing strap which extends from the top of an ISOFIX child restraint system to the top tether anchorage, and which is equipped with an adjustment device, a tension-relieving device, and a top tether connector."

Insert figures 1, 2 and 3, to read:  
"

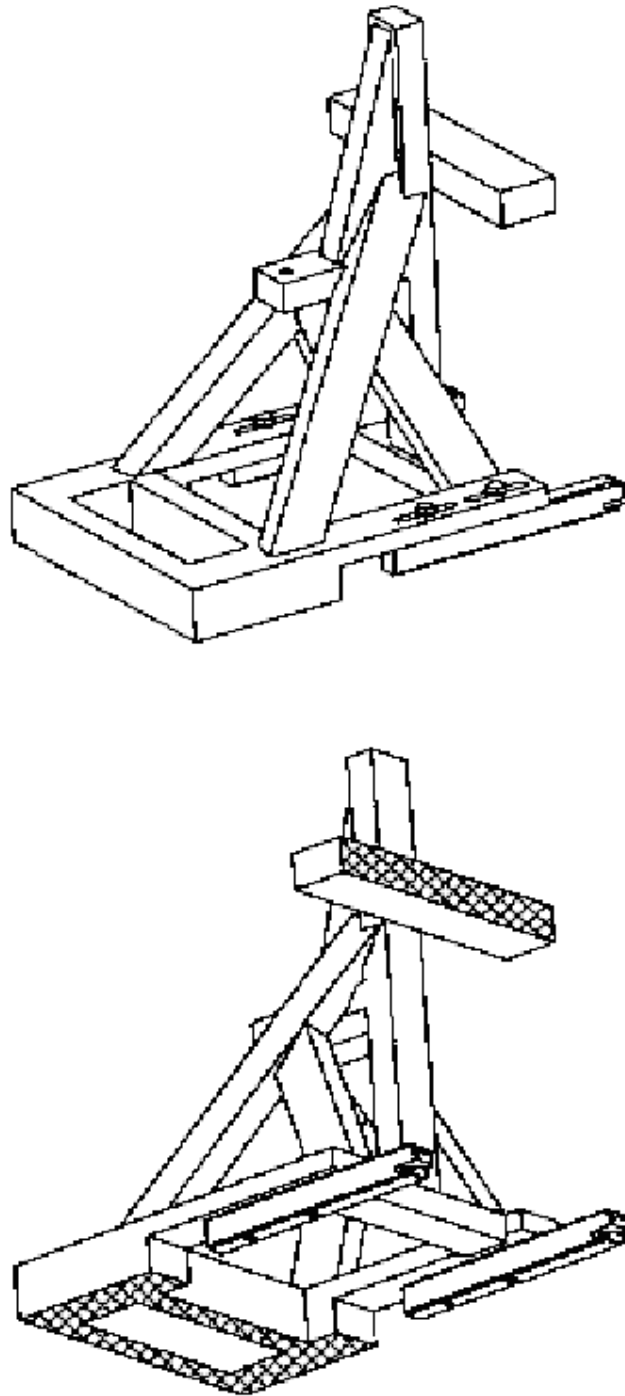

Figure 1: Static force application device (S-FAD), isometric views

Dimensions in millimetres

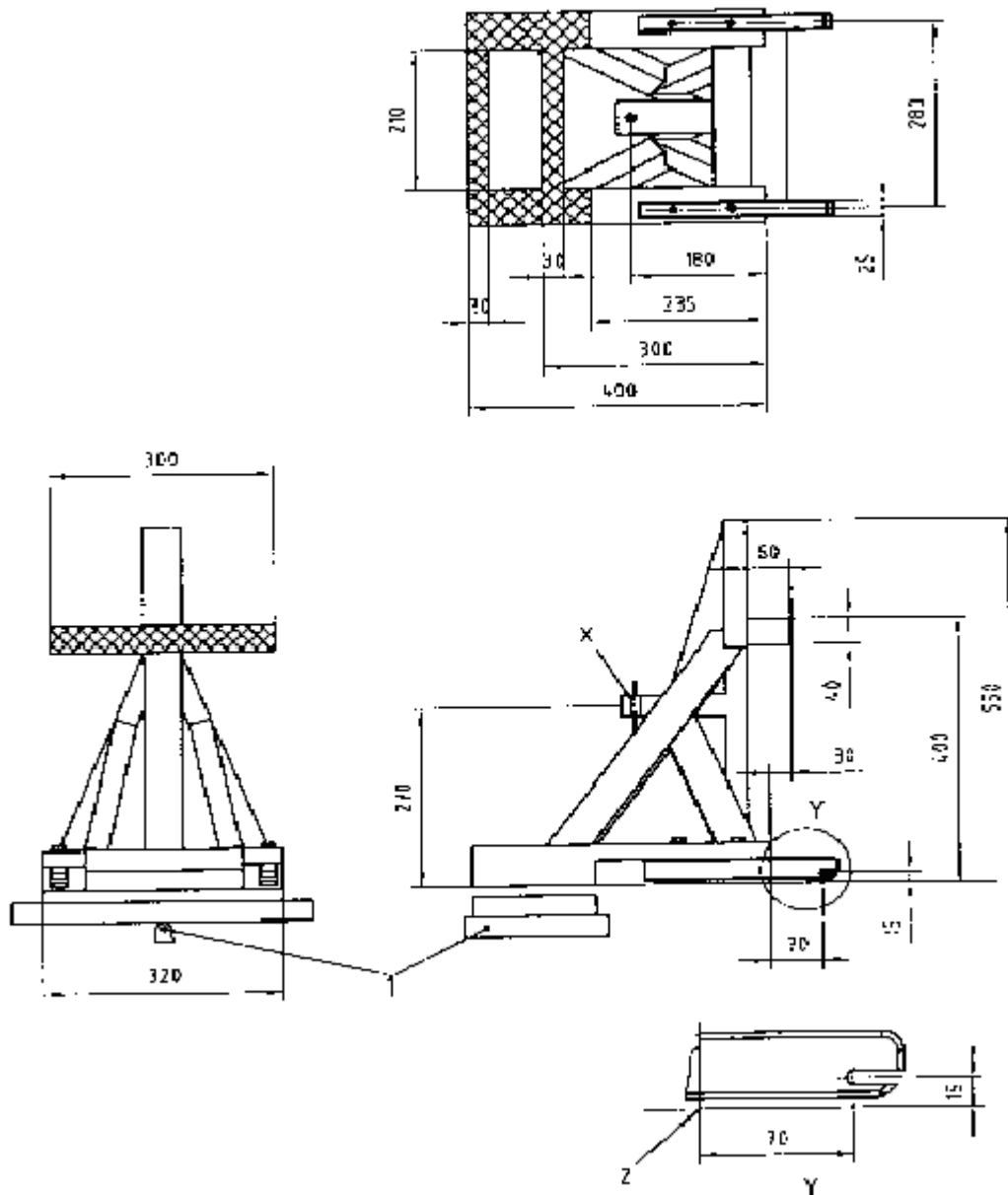

Figure 2: Static force application device (S-FAD), dimensions

Stiffness of S-FAD: When attached to rigid anchorage bar(s) with the front cross member of the S-FAD supported by a rigid bar that is held at the centre by a longitudinal pivot 25 mm below the S-FAD base (to allow bending and twisting of the S-FAD base) the movement of point X shall not be greater than 2 mm in any direction when forces are applied in accordance with table No. 1 of paragraph 6.6.4. of this regulation. Any deformation of the ISOFIX anchorages system shall be excluded from the measurements  
~~(e.g. the stiffness requirements will be fulfilled when using a securely welded construction consisting of rectangular 3mm steel tubing, and 6mm thick load application plate).~~

Dimensions in millimetres

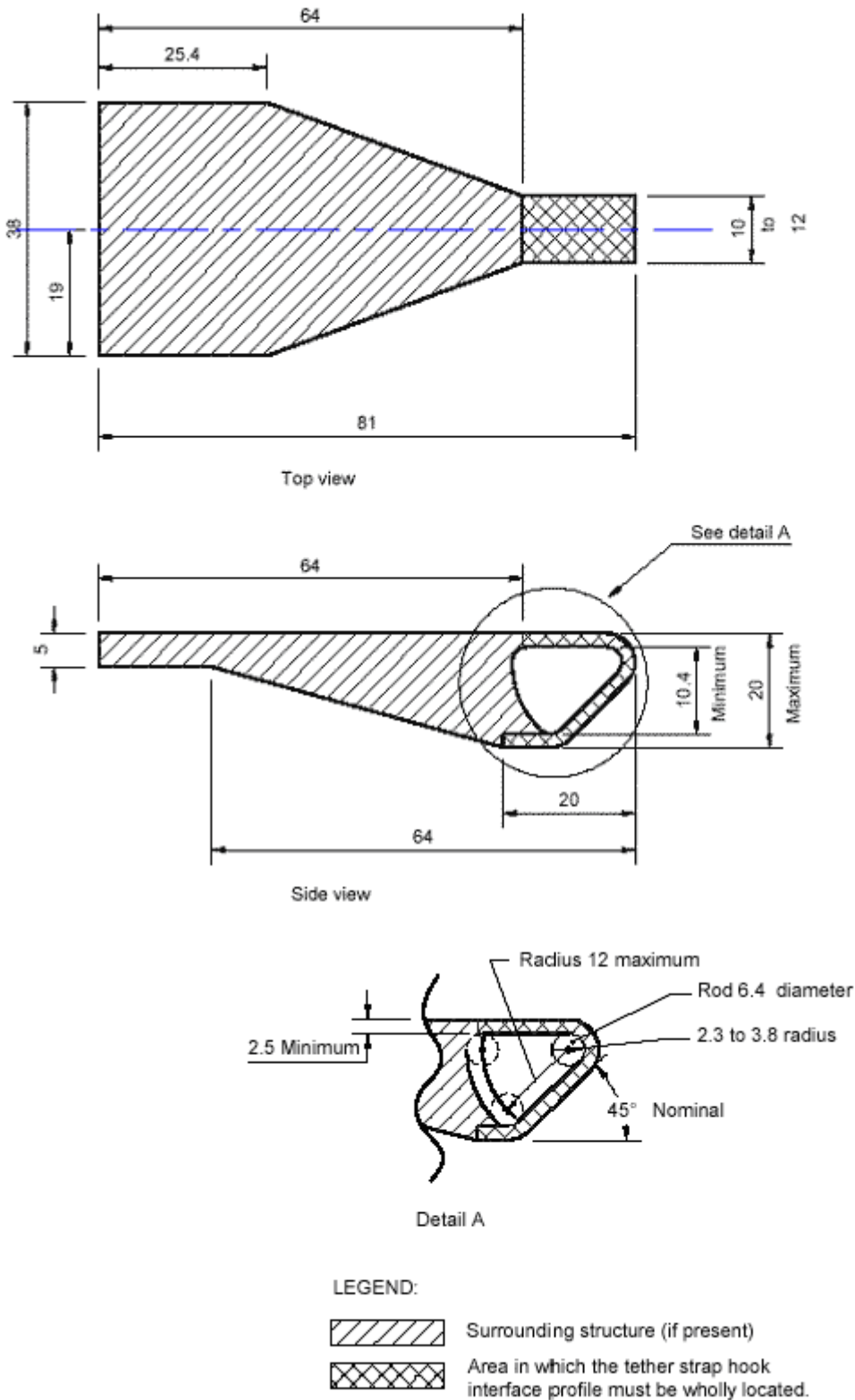

Figure 3: ISOFIX Top tether connector (hook type) dimensions

Paragraph 3.1., amend to read:

".....with regard to the belt anchorages, ~~and~~ the ISOFIX anchorages systems and the ISOFIX top tether anchorage if any shall be submitted .....

Paragraph 3.2.1., amend to read:

" .....showing the positions of the belt anchorages, ~~and~~ of the ISOFIX anchorages systems and of ISOFIX top tether anchorage if any, the effective belt anchorages (where appropriate), and detailed drawings of the belt anchorages ~~and of the ISOFIX anchorages systems~~ if any and of the point .....

Paragraph 3.2.2., amend to read:

".....of the belt anchorages, ~~and~~ of the ISOFIX anchorages systems, and of ISOFIX top tether anchorage if any;"

Paragraph 3.2.3., amend to read:

".....of the belt anchorages, ~~and~~ of the ISOFIX anchorages systems and ISOFIX top tether anchorage if any;"

Paragraph 3.2.4., amend to read:

" .....of belt anchorages, ~~and~~ of the ISOFIX anchorages systems, and of ISOFIX top tether anchorage if any affixed to the seat structure;"

Paragraph 3.3., amend to read:

" .....for the belt anchorage test, ~~and~~ for the ISOFIX anchorages systems and for ISOFIX top tether anchorage test if any by the technical .....

Paragraph 4.2., amend to read:

" .....Its first two digits (at present 06, corresponding to the 06 series of amendments) .....

Insert new paragraphs 5.2.2. to 5.2.4.3.3., to read:

"5.2.2           Any ISOFIX anchorages system and any ISOFIX top tether anchorage for ISOFIX child restraint systems shall be designed, made and situated as to:

5.2.2.1.       Any ISOFIX anchorages system shall be designed such as enable the vehicle, in normal use, to comply with the provisions of this Regulation.  
~~Aftermarket ISOFIX low anchorages shall also comply, for all the vehicle types for which they are intended to, with the provisions of this regulation.~~  
Any ISOFIX anchorages and ISOFIX top tether anchorage which could be added on any vehicle to be pre-fitted shall also comply with the provisions of this regulation. Consequently such anchorages shall be described on the application document for type approval.

Any ISOFIX anchorages systems and ISOFIX top tether anchorage shall be supported so as to extend from the adjacent vehicle or seat structure.

5.2.2.2 ISOFIX low anchorage system and ISOFIX top tether anchorage resistance is are designed for any ISOFIX child restraint systems of group of mass 0 ; 0+ ; 1 and 1+ as defined in Regulation No. 44. Whatever ISOFIX child restraint system class is integral or non-integral as defined in Regulation 44. The ISOFIX anchorages systems may be used for group of mass 2 and 3 only in case of non-integral class ISOFIX child restraint systems.

5.2.3 ISOFIX anchorage systems, design and positioning:

5.2.3.1. Any ISOFIX anchorages system shall be 6 mm ± 0.1 mm diameter transverse horizontal rigid bar(s) which cover(s) two zones of 25 mm minimum effective length located on the same axis as defined in figure 4.

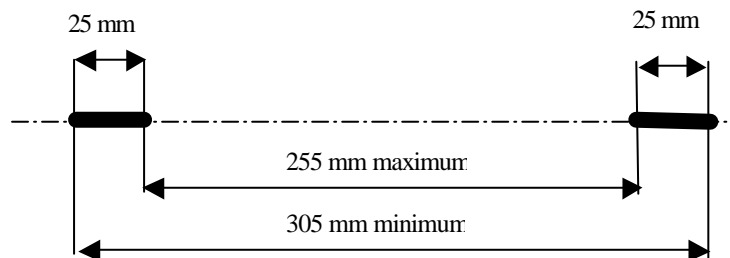

Figure 4: Distance between both low anchorage zones

5.2.3.2. Any ISOFIX anchorage system installed on a vehicle seating position shall be located not less than 120 mm behind "H" point as determined in annex 4 to this Regulation, measured horizontally and to the centre of the bar.

5.2.3.3. For any ISOFIX anchorages system installed in the vehicle, it shall be verified the possibility to attach the ISOFIX child restraint fixture "ISO 2" systems according described in Regulation No. 16.

5.2.3.4. The bottom surface of the fixture "ISO 2", as defined in Regulation No. 16, shall have attitude angles within the following limits, angles measured relative to the vehicle reference planes, as defined in annex 17 appendix 2 of this Regulation:

Pitch:  $15^{\circ} \pm 10^{\circ}$ ,

Roll:  $0^{\circ} \pm 5^{\circ}$ ,

Yaw:  $0^{\circ}$ .

5.2.3.5. ISOFIX low anchorage systems shall be permanently in position or storable. In case of storable anchorages, the requirements relating to ISOFIX anchorages system shall be fulfilled in the deployed position.

5.2.3.6. At least one Each anchorage bar (when deployed for use), one or each guidance fixture device (when installed), or each one seat marking feature, shall be readily visible to the CRS installer.

5.2.4. ISOFIX top tether anchorages, design and positioning: Alternatively, at the request of the car manufacturer, methods described in paragraphs 5.2.4.1. and 5.2.4.2. can be used.



Method described in paragraph 5.2.4.1. can only be used if the ISOFIX position is located on a vehicle seat.

- 5.2.4.1. Subject to paragraph 5.2.4.3. the portion of each top tether anchorage that is designed to bind with a top tether connector shall be located within the shaded zone - as shown in figure 5 to 10 - of the designated seating position for which it is installed, with the reference of a template described in annex 4 of this Regulation, if,
- 5.2.4.1.1. The "H" point of the template is located at the unique design "H" point of the full downward and full rearward position of the seat, except that the template is located laterally midway between the two ISOFIX lower anchorages;
- 5.2.4.1.2. The torso line of the template is at the same angle to the vertical plane as the vehicle seat in its most upright position, and
- 5.2.4.1.3. the template is positioned in the vertical longitudinal plane that contains the H-point of the template.
- 5.2.4.2. The ISOFIX top tether anchorage zone may be alternatively located with the aid of the Fixture "ISO 2", as defined in Regulation No. 16, in an ISOFIX position equipped with ISOFIX low anchorages as shown in figure 10. In the side view, the top tether anchorages shall lie behind a lateral plane containing the Fixture "ISO 2" vertical reference line and probe and below a lateral plane passing through the intersection of the "ISO 2" fixture reference line and the plane containing the underside of the seat top bar, and extending rearward at an angle of 45° above the horizontal.
- In the plan view, the top tether anchorage zone shall lie between the planes extending rearward and laterally from the tether reference point, and separated by an angle of 90°. Further, the ISOFIX top tether anchorage shall be more than 200 mm but not more than 1000mm from the origin of the top tether strap on the rear face of the "ISO 2" fixture, measured along the strap when it is drawn over the seat back to the anchorage.
- 5.2.4.3. The portion of the ISOFIX top tether anchorage in a vehicle that is designed to bind with the top tether connector may be located outside the shaded zones referred to paragraphs 5.2.4.1. or 5.2.4.2. if a location within a zone is not appropriate and the vehicle is equipped with a routing device that,
- 5.2.4.3.1. ensures that the ISOFIX top tether strap functions as if the portion of the anchorage designed to bind with the ISOFIX top tether anchorage were located within the shaded zone; and,
- 5.2.4.3.2. is at least 65 mm behind the torso line, in case of a non-rigid webbing-type routing device or a deployable routing device, or at least 100 mm behind the torso line, in the case of a fixed rigid routing device; and,
- 5.2.4.3.3. when tested after being installed as it is intended to be used, is of sufficient strength to withstand, with the ISOFIX top tether anchorage the load referred to in paragraph 6.6. of this Regulation."

Insert figures 5, 6, 7, 8, 9, and 10 to read:  
 "

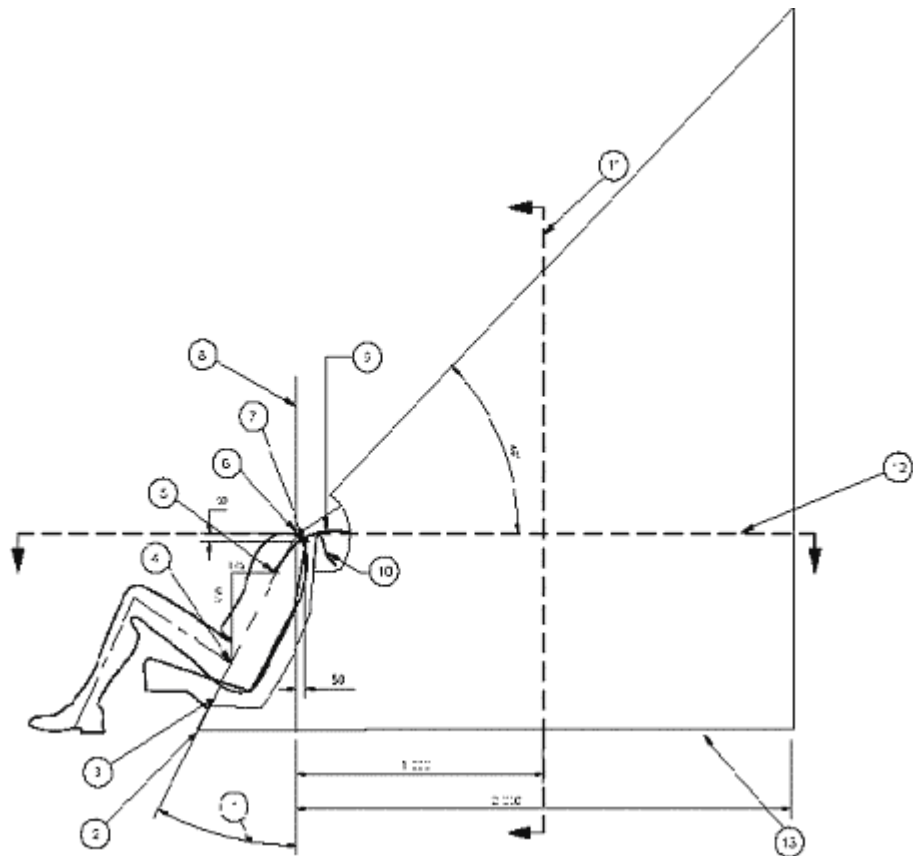

**Key**

- 1 Back angle
- 2 Intersection of torso line reference plane and floor pan
- 3 Torso line reference plane
- 4 H-point
- 5 "V" point
- 6 "R" point
- 7 "W" point
- 8 Vertical longitudinal plane
- 9 Strap wrap-around length from "V" point: 250 mm
- 10 Strap wrap-around length from "W" point: 200 mm
- 11 "M" plane cross-section
- 12 "R" plane cross-section
- 13 Line represents the vehicle specific floor pan surface within the prescribed zone

NOTE 1 Portion of top tether anchorage that is designed to bind with the top tether hook to be located within shaded zone

NOTE 2 "R" Point: Shoulder reference point

NOTE 3 "V" Point: V-reference point, 350 mm vertically above and 175 mm horizontally back from H-point

NOTE 4 "W" Point: W-reference point, 50 mm vertically below and 50 mm horizontally back from "R" point

NOTE 5 "M" Plane: M-reference plane, 1 000 mm horizontally back from "R" point

NOTE 6 The forwardmost surfaces of the zone are generated by sweeping the two wraparound lines throughout their extended range in the front part of the zone. The wraparound lines represent the minimum adjusted length of typical top tether straps extending from either the top of the CRS (W-point), or lower on the back of the CRS (V-point).

**Figure 5: ISOFIX Top tether anchorage location, ISOFIX zone - Side view**

Dimensions in millimetres

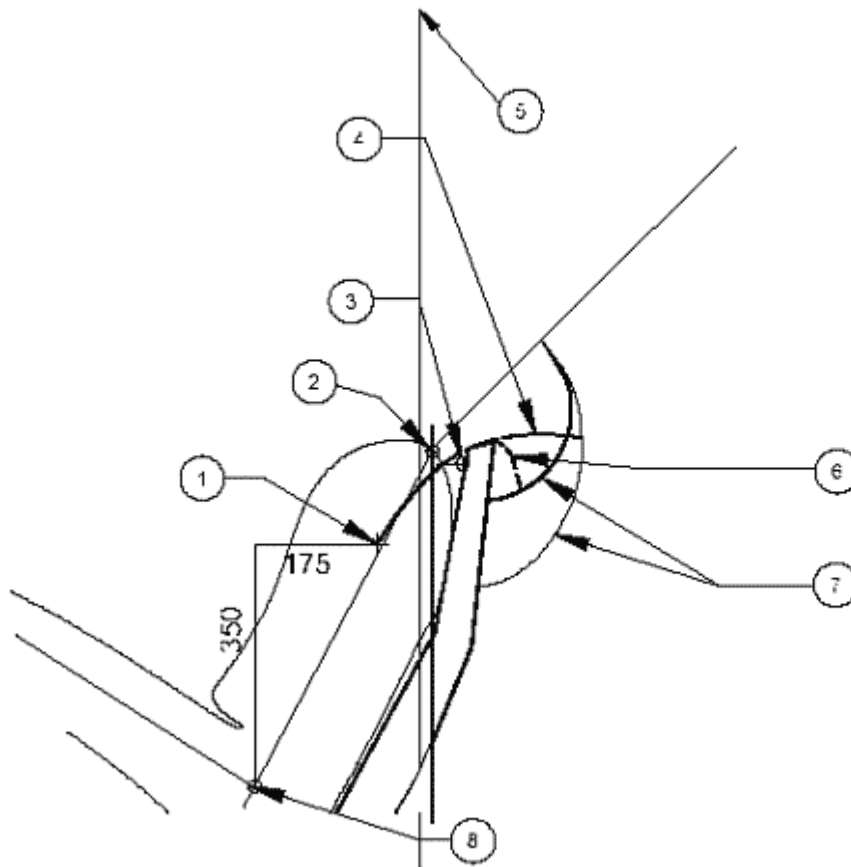

**Key**

- 1 "V" point
- 2 "R" point
- 3 "W" point
- 4 Strap wrap-around length from "V" point: 250 mm
- 5 Vertical longitudinal plane
- 6 Strap wrap-around length from "W" point: 200 mm
- 7 Arcs created by wrap-around lengths
- 8 H-point

NOTE 1 Portion of top tether anchorage that is designed to bind with the top tether hook to be located within shaded zone

NOTE 2 "R" point: Shoulder reference point

NOTE 3 "V" point: V-reference point, 350 mm vertically above and 175 mm horizontally back from H-point

NOTE 4 "W" point: W-reference point, 50 mm vertically below and 50 mm horizontally back from "R" point

NOTE 5 "M" plane: M-reference plane, 1000 mm horizontally back from "R" point

NOTE 6 The forwardmost surfaces of the zone are generated by sweeping the two wraparound lines throughout their extended range in the front part of the zone. The wraparound lines represent the minimum adjusted length of typical top tether straps extending from either the top of the CRS (W-point), or lower on the back of the CRS (V-point).

**Figure 6: ISOFIX Top tether anchorage location, ISOFIX zone - Enlarged side view of wrap-around area**

Dimensions in millimetres

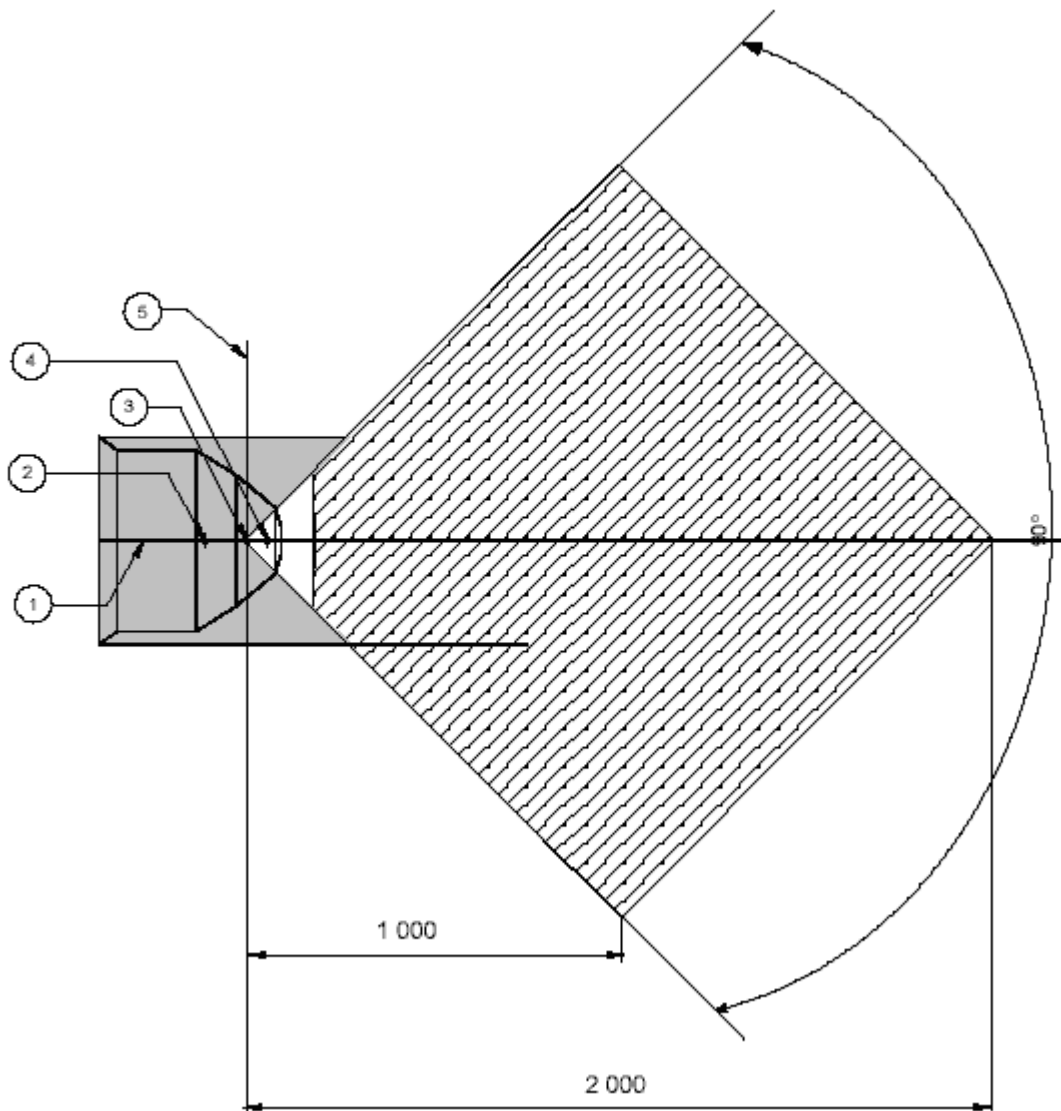

**Key**

- 1 Median plane
- 2 "V" point
- 3 "R" point
- 4 "W" point
- 5 Vertical longitudinal plane

NOTE 1 Portion of top tether anchorage that is designed to bind with the top tether hook to be located within shaded zone

NOTE 2 "R" point: Shoulder reference point

NOTE 3 "V" point: V-reference point, 350 mm vertically above and 175 mm horizontally back from H-point

NOTE 4 "W" point: W-reference point, 50 mm vertically below and 50 mm horizontally back from "R" point

**Figure 7: ISOFIX Top tether anchorage location, ISOFIX zone - Plan view (R-plane cross section)**

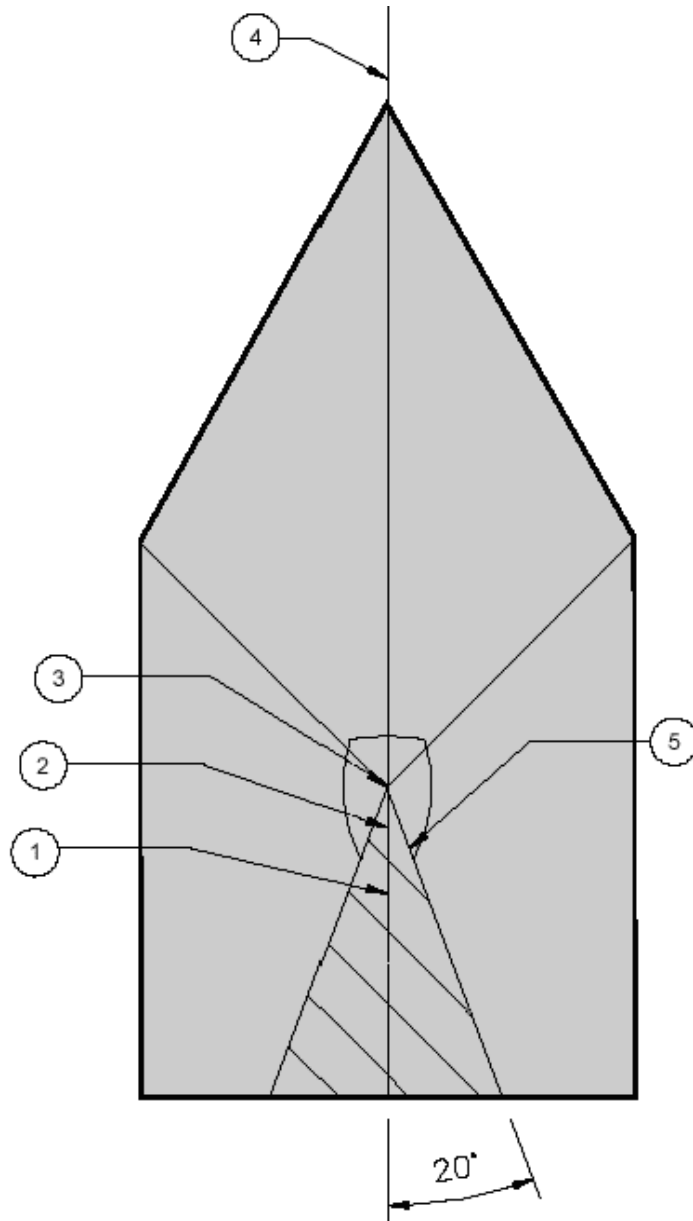

**Key**

- 1 "V" point
- 2 "W" point
- 3 "R" point
- 4 Median plane
- 5 Area view along torso reference plane

NOTE 1 Portion of top tether anchorage that is designed to bind with the top tether hook to be located within shaded zone

NOTE 2 "R" point: Shoulder reference point

NOTE 3 "V" point: V-reference point, 350 mm vertically above and 175 mm horizontally back from H-point

NOTE 4 "W" point: W-reference point, 50 mm vertically below and 50 mm horizontally back from "R" point

**Figure 8: ISOFIX Top tether anchorage location, ISOFIX zone - Front view**

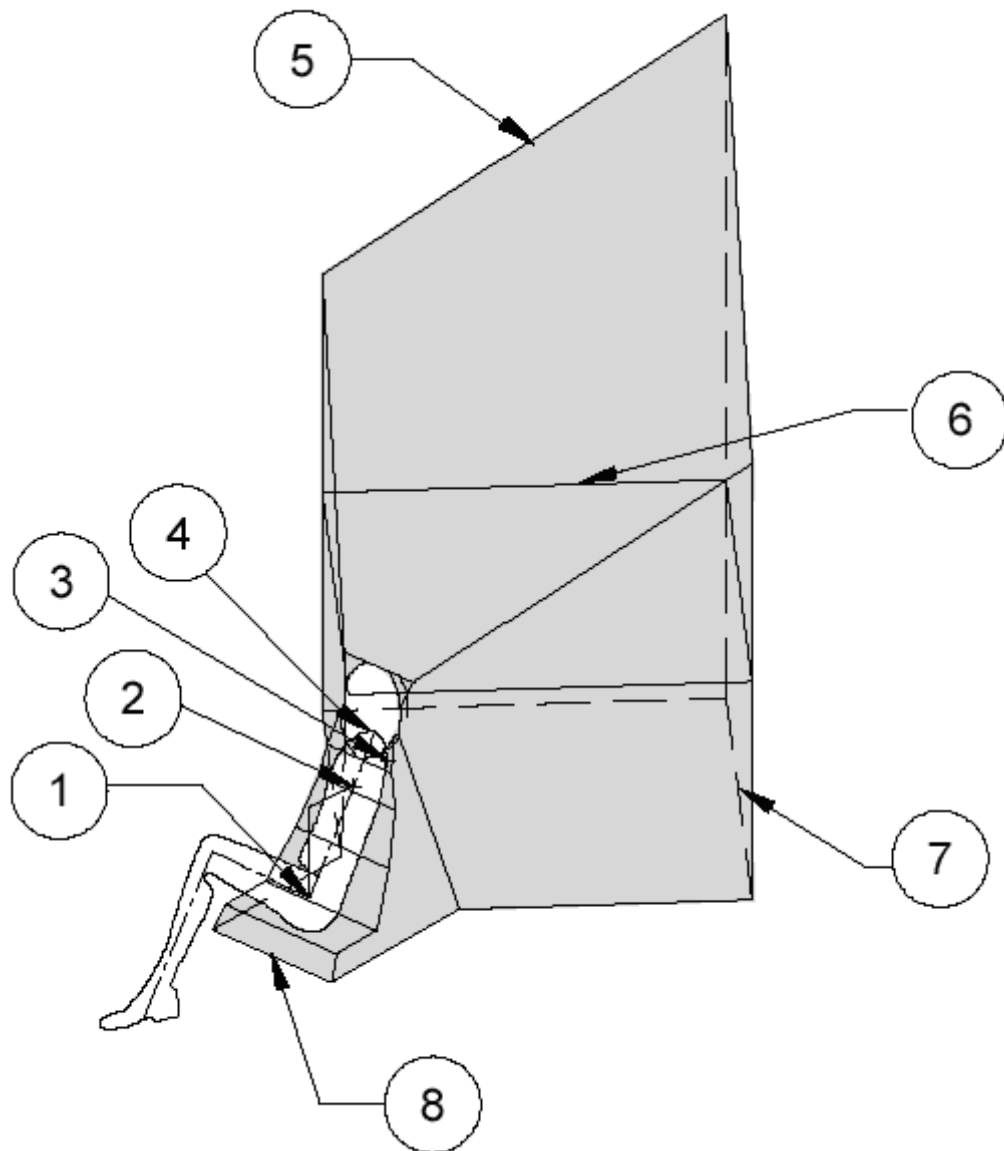

**Key**

- 1 H-point
- 2 "V" point
- 3 "W" point
- 4 "R" point
- 5 45° plane
- 6 "R" plane cross-section
- 7 Floor pan surface
- 8 Front edge of zone

NOTE 1 Portion of top tether anchorage that is designed to bind with the top tether hook to be located within shaded zone

NOTE 2 "R" point: Shoulder reference point

**Figure 9: ISOFIX Top tether anchorage location, ISOFIX zone - Three-dimensional schematic view**

Dimensions in millimetres

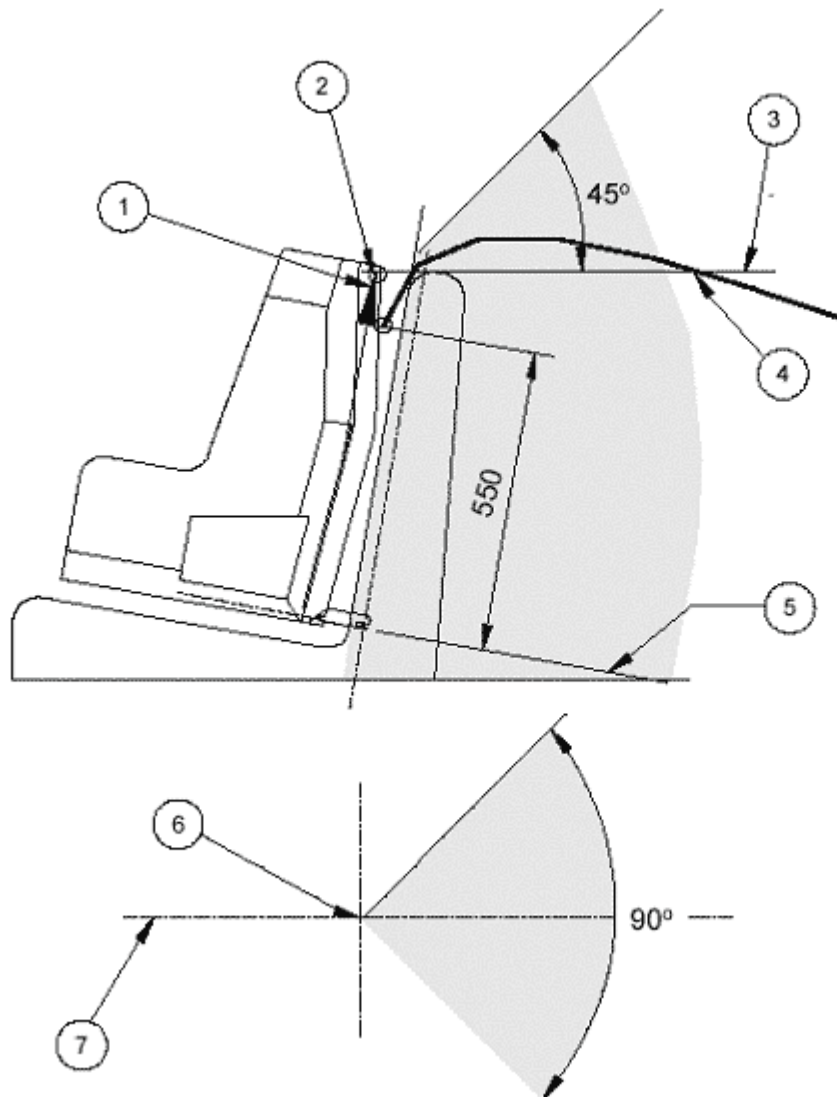

**Key**

- |   |   |
|---|---|
| 1 | CRF vertical reference probe                            |
| 2 | Top tether reference line                               |
| 3 | Horizontal line   |
| 4 | Top tether wrap around length from fixture: 200-1000 mm |
| 5 | CRF horizontal reference plane                          |
| 6 | Tether reference point                                  |
| 7 | Centreline of CRF                                       |

Figure 10: Alternative method of locating the top tether anchorage using the ISOFIX Child Restraint Fixture, ISOFIX zone - Side and plan views"

Insert new paragraphs 5.3.10.1. to 5.3.10.5., to read:

"5.3.10. Minimum number of ISOFIX positions ~~anchorage systems~~ to be provided.

- 5.3.10.1.** Any vehicle of category M1 must be equipped at least with two ISOFIX positions.  
At least two of the ISOFIX positions shall be equipped both with an ISOFIX anchorage system and an ISOFIX top tether anchorage.  
The type and number of ISOFIX fixture, defined in Regulation No. 16, which can be installed on each ISOFIX position is defined in Regulation No. 16.
- ~~5.3.10.1.2. Notwithstanding with 5.3.10.1. only one ISOFIX anchorages system shall be provided on the front seat row in the case of the two following vehicle concepts:  
- Either, no rear seat row is provided or,  
- There is not enough sufficient space available between two seat rows measured as follows: with the seats and seat backs adjusted as specified in paragraph 5.3.10.1.2.1., the distance measured along a longitudinal horizontal line tangent to the highest point of the rear seat bottom cushion in the suitable longitudinal vertical plane, describe in paragraph 5.3.10.1.2.2., between the rearward surface of the front seat back and the forward surface of the rear seat back is less than 720 mm.~~
- ~~5.3.10.1.2.1 Adjustable front seats are in the adjustment position midway between the forwardmost and rearmost positions, and if separately adjustable in a vertical direction, are at the lowest position. If an adjustment position doesn't exist midway between the forwardmost and rearmost positions, the closest adjustment position to the rear of the midpoint is used. Place adjustable seat backs in the manufacturer's nominal design riding position in the manner specified by the manufacturer~~
- ~~5.3.10.1.2.2. In a vehicle equipped with front separate side by side seats, the vertical plane to be taken into account in paragraph 5.3.10.1.2. is located at the centreline of the driver's seat cushion.  
In a vehicle equipped with front bench seating, the reference vertical plane mentioned above passes through the centre of the steering wheel rim.~~
- 5.3.10.2.** Notwithstanding paragraph 5.3.10.1. if a vehicle is only equipped with one seat row, no ISOFIX position is required.
- 5.3.10.3.** Notwithstanding paragraph 5.3.10.1. one of the two ISOFIX positions systems shall be installed at the second seat row.
- 5.3.10.4.** If an ISOFIX anchorage system is installed at a front seating position protected with a frontal airbag, a de-activation device for this airbag shall be fitted.
- 5.3.10.5.** Notwithstanding paragraph 5.3.10.1. in case of integrated "built in" child restraint system(s) the number of ISOFIX positions anchorages systems to be provided shall be at least two minus the number of the integrated "built in" child restraint system(s) of mass groups 0, or 0+, or 1, or 1+."

Paragraph 5.3.10. (former), renumber as paragraph 5.3.11.

Paragraphs 6.1. and 6.2., amend to read:

"6.1. General for seat belt anchorages tests.



6.2. Securing the vehicle for seat belt anchorages tests and for ISOFIX anchorages ~~systems~~ tests."

Paragraph 6.2.1., amend to read:

".....as to strengthen the seat belt anchorages or the ISOFIX anchorages ~~systems~~ and their anchorage area..... "

Paragraph 6.3., amend to read:

"6.3. General test requirements for seat belt anchorages."

Paragraph 6.4., amend to read:

"6.4. Particular test requirements for seat belt anchorages."

Insert new paragraphs 6.6. to 6.6.5.1., to read:

"6.6. Static test requirements.

6.6.1. The strength of the ISOFIX anchorage systems and the ability of the vehicle or seat structure to limit the rotation shall be tested applying the forces, as prescribed in paragraph 6.6.4.3., to the static force application device (S-FAD) with ISOFIX attachments well engaged.

In case of ISOFIX top tether anchorage an additional test shall be performed as prescribed in paragraph 6.6.4.4.

~~In case of several ISOFIX anchorage systems are installed on a seat row, the test shall be carried out simultaneously with all the ISOFIX anchorage systems fitted on this seat row.~~

All the ISOFIX positions of the same seat row shall be tested simultaneously.

6.6.2. The test may be carried out either on a completely finished vehicle or on sufficient parts of the vehicle so as to be representative of the strength and rigidity of the vehicle structure.

Windows and doors may be fitted or not and closed or not.

Any fitting normally provided and likely to contribute to the vehicle structure may be fitted.

The test may be restricted to the ISOFIX ~~anchorages system~~ position relating to only one seat or group of seat on the condition that:

-The ISOFIX ~~anchorages system~~ position concerned have the same structural characteristics as the ISOFIX ~~anchorages system~~ position relating to the other seats or group of seats and,

-Where such ISOFIX ~~anchorages systems~~ position are fitted totally or partially on the seat or group of seats, the structural characteristics of the seat or group of seats are the same as those for the other seats or groups of seats.

6.6.3. If the seats and head restraint are adjustable, they shall be placed in the position specified by the car manufacturer as prescribed in appendix 2 of annex 17 of Regulation No. 16.

6.6.4. Forces, directions and excursion limits.

6.6.4.1. A force of 135N ± 15N shall be applied to the centre of the lower front crossbar of the S-FAD in order to adjust the fore-aft position of the S-FAD rearward extension to remove any slack or tension between the S-FAD and its support.

6.6.4.2. Forces shall be applied to the static force application device (S-FAD) in forward and lateral directions according to table 1.

Table 1: Directions of test forces

Forward	0° ± 5°	8 kN ± 0.25 kN
Lateral	75° ± 5° (to both sides of straight forward or if any worst case side)	[5 kN] ± 0.25 kN

Each of these test may be performed on different structures if the manufacturer so requests.

Forces in the forward direction shall be applied with an initial force application angle of 10 ± 5° above the horizontal. Lateral forces shall be applied horizontally 0° ± 5°. A pre-load force of 500 N ± 25 N shall be applied at the prescribe loading point X indicated in figure 2. Full application of the force shall achieved within a period of 2 s or less. The force shall be maintained for a minimum period of 0.2 s.

All measurements shall be made according to ISO 6487 with CFC of 60 Hz or any equivalent method.

6.6.4.3. Tests with ISOFIX attachments:

6.6.4.3.1. First test:

Horizontal excursion (after pre-load) of point X during application of the 8 kN ± 0.25 kN force shall be limited to 125 mm and permanent deformation including partial rupture or breakage of any ISOFIX low anchorage or surrounding area shall not constitute failure if the required force is sustained for the specified time.

6.6.4.3.2. Second test:

Lateral excursion (after pre-load) of point X during application of the [5kN] ± 0.25 kN force shall be limited to [125 mm] and permanent deformation including partial rupture or breakage of any ISOFIX low anchorage or surrounding area shall not constitute failure if the required force is sustained for the specified time. ~~Rotation (yaw) of the fixture during application of the 8 kN forward force shall not exceed [ 15° ].~~

6.6.4.4. Test with ISOFIX attachments and ISOFIX top tether strap:

Horizontal excursion (after pre-load) of point X during application of the 8 kN ± 0.25 kN force shall be limited to 125 mm and permanent deformation including partial rupture or breakage of any ISOFIX low anchorage or surrounding area shall not constitute failure if the required force is sustained for the specified time.

Table 2: Excursions limits

Force direction	Maximum excursion of point X of S-FAD
Forward	125 mm (longitudinal)
Lateral	[125 mm] (transversal)

6.6.5. Additional forces.

6.6.5.1. Seat inertia forces.

For the installation position where the load is transferred into a vehicle seat assembly, and not directly into the vehicle structure, a test shall be carried out to ensure that the strength of the vehicle seat attachment to the vehicle structure is sufficient. In this test, in addition to the force of 8 kN ± 0,25 kN applied to point X, a force equal to 20 times the mass of the relevant parts of the seat assembly shall be applied horizontally and longitudinally in a forward direction to the seat or the relevant part of the seat assembly corresponding to the physical effect of the mass of the seat in question to the seat anchorages. The determination of the additional applied load or loads and the load distribution shall be made by the manufacturer and agreed by the Technical Service. At the request of the manufacturer, the additional load can be applied at the X point of SFAD.  
If the top tether anchorage is integrated to the vehicle seat, this test shall be performed with the ISOFIX top tether strap.  
No breakdown shall occur.

NOTE This test does not have to be performed in case any anchorage of the vehicle seat belt system is integrated to the vehicle seat structure, and the vehicle seat is already tested and approved to meet at least the above requirement.

Paragraph 7., amend to read:

"INSPECTION DURING AND AFTER STATIC TESTS FOR SAFETY BELT ANCHORAGES."

Paragraph 9., amend to read:

" .....with regard to details affecting the characteristics of the safety belt anchorages and the ISOFIX anchorages system and ISOFIX top tether anchorage."

Paragraph 10., amend to read:

".....complied with or if its safety belt anchorages or the ISOFIX anchorages systems and ISOFIX top tether anchorage failed to pass the checks prescribed ....." "

Paragraph 12.1., amend to read:

" .....a type of safety belt anchorages or a type of ISOFIX anchorage systems and ISOFIX top tether anchorage approved in accordance with this Regulation ..."

Paragraph 14.1., amend to read:

"14.1. As from the official date of entry into force of the [05] 06 series of amendments, no contracting Party...as amended by the [05] 06 series of amendments."

Paragraph 14.2., amend to read:

"14.2. As from [ 2 years after the publication of the amendment] ~~after the date of entry into force~~ of the [05] 06 series of amendment to this Regulation, Contracting Parties applying this Regulation shall grant ECE approvals only if the requirements of this Regulation, as amended by the [05] 06 series of amendments are satisfied."

Paragraph 14.3., amend to read:

"14.3. As from [ **5 years after the date for NT**] ~~after the date of entry into force of the [05]~~ **06** series of amendment to this Regulation, Contracting Parties applying this Regulation may refuse to recognize approvals which were not granted in accordance with the [05] **06** series of amendments to this Regulation."

Annex 1

The subtitle, amend to read:

" .....of a vehicle type with regard to safety belt anchorages **and ISOFIX anchorages systems and ISOFIX top tether anchorage if any** ~~pursuant to... or of aftermarket ISOFIX low anchorages~~ pursuant to Regulation No. 14 3/"

Item 1., amend to read:

"1. Trade name or mark of the power-driven vehicle, ~~or of the aftermarket ISOFIX low anchorages~~ manufacturer "

Item 10., amend to read:

"10. **Vehicle or aftermarket ISOFIX low anchorages submitted for approval on ...**"

Item 15., amend to read:

"15. **Position of approval mark on vehicle or on aftermarket ISOFIX low anchorages on vehicle ...**"

Item 19., amend to read:

"... drawings, diagrams and plans of the belt anchorages, **of the - aftermarket - ISOFIX anchorages systems, if any,** and of the vehicle structure;"

Item 20., amend to read:

"... photographs of the belt anchorages, **of the - aftermarket - ISOFIX anchorages systems, if any,** and of the vehicle structure."

3/ Only if the **belt anchorage and the -aftermarket- ISOFIX anchorage systems, if any, are** affixed on the seat or if the seat supports ...

---

Annex 2,

Annex 2, in the examples of the approval marks and in the captions below amend the approval number "052439" to read "062439" (3 times, related to Regulation No. 14). In addition, in the caption below Model A of the approval mark amend the words "05 series of amendments" to read "06 series of amendments". The caption below Model B of the approval mark amend to read as follows (footnote \*/ not modified):

"... on the dates on which these approvals were granted Regulation No. 14 included the 05 series of amendments and Regulation No. 24 was in its 03 series of amendments."

Replace the current reference ["14R - 052439"] situated on the right of the second drawing of the approval mark by the following one "**14R 062439**"

---