



**Economic and Social
Council**

Distr.
GENERAL

TRANS/WP.29/2001/61
24 August 2001

Original: ENGLISH

ECONOMIC COMMISSION FOR EUROPE

INLAND TRANSPORT COMMITTEE

World Forum for Harmonization of Vehicle Regulations (WP.29)
(One-hundred-and-twenty-fifth session,
6-9 November 2001, agenda item 5.2.14.)

PROPOSAL FOR DRAFT SUPPLEMENT 2 TO THE 01 SERIES
OF AMENDMENTS TO REGULATION No. 67

(Equipment for liquefied petroleum gas)

Transmitted by the Working Party on Pollution and Energy (GRPE)

Note: The text reproduced below was adopted by GRPE at its forty-second session, and is transmitted for consideration to WP.29 and to AC.1. It is based on the text of a document distributed during the session without a symbol (informal document No. 25) (TRANS/WP.29/GRPE/42, para. 27).

This document is a working document circulated for discussion and comments. The use of this document for other purposes is the entire responsibility of the user. Documents are also available via the INTERNET:
<http://www.unece.org/trans/main/welcwp29.htm>

A. PROPOSAL

Paragraph 6.15.10.1., amend to read:

"6.15.10.1. The filling unit shall be equipped with at least one soft-seated non-return valve, and it shall not be dismountable by design."

Paragraph 6.15.10.3., amend to read (footnote */ not modified):

"6.15.10.3. The design and dimensions of the connecting area of the filling unit must comply with those in the figures in annex 9.

The filling unit shown in figure 5 is only applicable for motor vehicles of categories M2, M3, N2, N3 and M1 having a maximum total mass > 3,500 kg. */"

Insert a new paragraph 6.15.10.4., to read:

"6.15.10.4. The filling unit shown in figure 4 may also apply for motor vehicles of categories M2, M3, N2, N3 and M1 having a maximum total mass > 3,500 kg."

Paragraph 6.15.10.4. (former), renumber as paragraph 6.15.10.5.

Insert new paragraphs 6.15.10.6. to 6.15.10.7.2., to read:

"6.15.10.6. Specific provisions regarding the light vehicle Euro filling unit (Annex 9 - Figure 3):

6.15.10.6.1. The dead volume between the front sealing surface and the front of the non-return valve shall not exceed 0.1 cm³;

6.15.10.6.2. The flow through the connector at a pressure difference of 300 kPa shall be at least 60 litres/min, if tested with water.

6.15.10.7. Specific provisions regarding the heavy-duty vehicle Euro filling unit (Annex 9 - Figure 5):

6.15.10.7.1. The dead volume between the front sealing surface and the front of the non-return valve shall not exceed 0.5 cm³;

6.15.10.7.2. The flow through the filling unit, with the non-return valve mechanically opened, at a pressure difference of 500 kPa shall be at least 200 litres/min, when tested with water."

Annex 9,

Paragraph 6., amend to read:

"6.	Applicable test procedures:	
	Over pressure test	Annex 15, para. 4
	External leakage	Annex 15, para. 5
	High temperature	Annex 15, para. 6
	Low temperature	Annex 15, para. 7
	Seat leakage test	Annex 15, para. 8
	Endurance	Annex 15, para. 9 (with 6,000 operation cycles)
	LPG compatibility	Annex 15, para. 11 **/
	Corrosion resistance	Annex 15, para. 12 */
	Resistance to dry heat	Annex 15, para. 13
	Ozone ageing	Annex 15, para. 14
	Creep	Annex 15, para. 15 **/
	Temperature cycle	Annex 15, para. 16 **/
	Impact test	paragraph 7 of this annex

*/ only for metallic parts

**/ only for non-metallic parts

Remarks:

- The overpressure test has to be performed on each non-return valve.
- The endurance test shall be carried out with a nozzle specifically intended for the filling unit under test. 6,000 cycles shall be applied according to the following procedure:
 - connect the nozzle to the connector and open the filling unit system;
 - leave in open situation for at least 3 seconds;
 - close the filling unit and disconnect the nozzle."

Insert new paragraphs 7. to 7.4., to read:

"7. Impact test requirements

7.1. General requirements

The filling unit shall be subjected to an impact test of 40 J.

7.2. Test procedure

A hardened steel mass of 4 kg shall be dropped from a height of 1 m so as to deliver the impact velocity 4.4 m/s. This shall be achieved by mounting the mass in a pendulum.

The filling unit shall be installed horizontally on a solid object. The impact of the mass shall be on the centre of the protruding part of the filling unit.

7.3. Test interpretation

The filling unit shall comply with the external leak test and seat leak test at ambient temperature.

7.4. Re-testing

If the filling unit fails the test, 2 samples of the same component shall be submitted to the impact test. If both samples pass the test, the first test shall be ignored.
In the event where one or both fail the re-test, the component shall not be approved."

Figure 1, insert a title, to read:

"Figure 1: connecting area of the Bayonet filling unit"

Figure 2, insert a title, to read:

"Figure 2: connecting area of the Dish filling unit"

Insert a new Figure 3, to read:

"

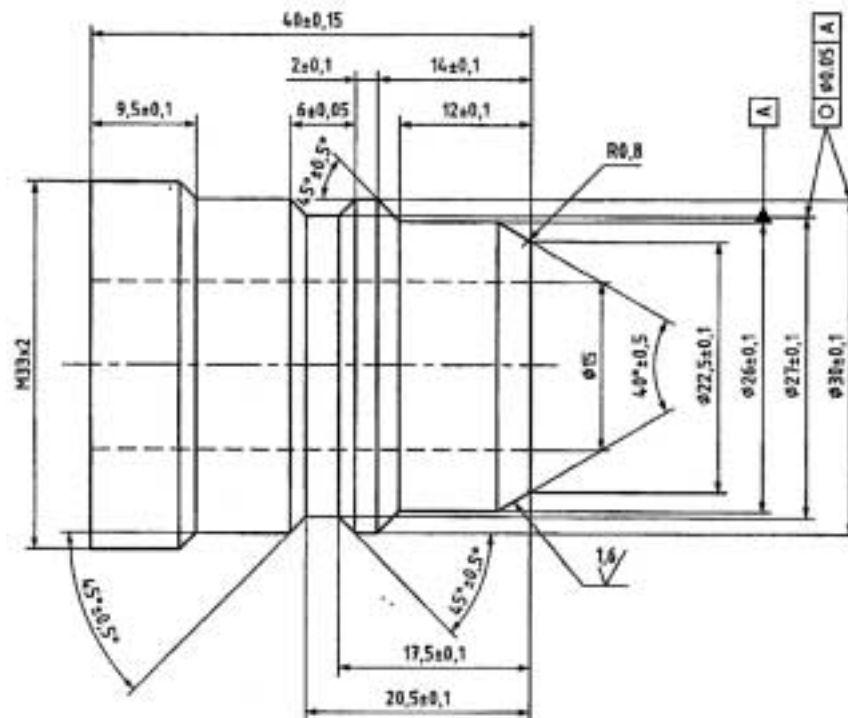

Figure 3: connecting area of the light vehicle Euro filling unit"

Figure 3 (former), renumber as Figure 4 and amend its title to read (deleting also the reference to footnote 1/ and footnote 1/):

"Figure 4: connecting area of the ACME filling unit"

Insert a new Figure 5, to read:

"

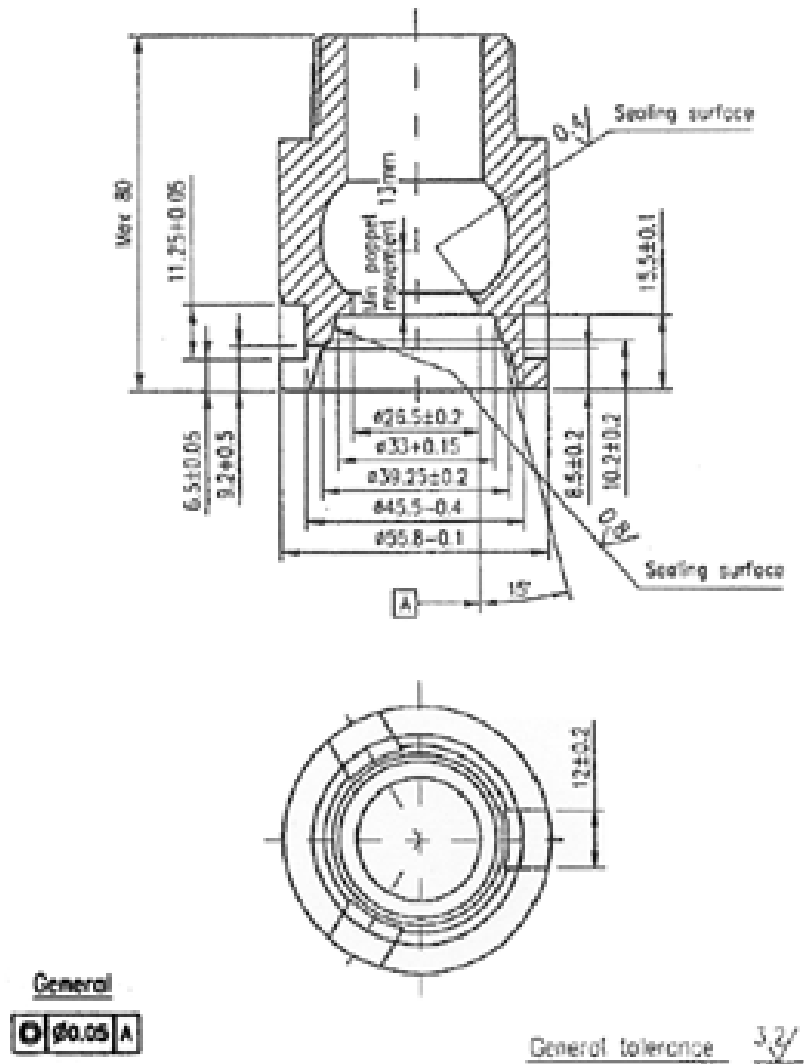

Figure 5: Connecting area of the heavy-duty vehicle Euro filling unit"