

11 March 1996

## AGREEMENT

### CONCERNING THE ADOPTION OF UNIFORM TECHNICAL PRESCRIPTIONS FOR WHEELED VEHICLES, EQUIPMENT AND PARTS WHICH CAN BE FITTED AND/OR BE USED ON WHEELED VEHICLES AND THE CONDITIONS FOR RECIPROCAL RECOGNITION OF APPROVALS GRANTED ON THE BASIS OF THESE PRESCRIPTIONS \*/

(Revision 2, including the amendments entered into force on 16 October 1995)

---

*Addendum 50: Regulation No. 51*

#### **Revision 1**

**Incorporating:**

Supplement 1 to the original version of the Regulation - Date of entry into force: 21 October 1984

01 series of amendments - Date of entry into force: 27 April 1988

Corrections referred to in the Depositary Notification C.N.91.1988 TREATIES-25 of 20 June 1988

Supplement 1 to the 01 series of amendments - Date of entry into force: 12 September 1991

02 series of amendments - Date of entry into force: 18 April 1995

Supplement 1 to the 02 series of amendments - Date of entry into force: 5 May 1996

### UNIFORM PROVISIONS CONCERNING THE APPROVAL OF MOTOR VEHICLES HAVING AT LEAST FOUR WHEELS WITH REGARD TO THEIR NOISE EMISSIONS



UNITED NATIONS

---

\*/ Former title of the Agreement:

Agreement Concerning the Adoption of Uniform Conditions of Approval and Reciprocal Recognition of Approval for Motor Vehicle Equipment and Parts, done at Geneva on 20 March 1958.

GE.96-21189



Regulation No. 51

UNIFORM PROVISIONS CONCERNING THE APPROVAL OF MOTOR VEHICLES HAVING AT LEAST  
FOUR WHEELS WITH REGARD TO THEIR NOISE EMISSIONS

CONTENTS

	<u>Page(s)</u>
1. Scope .....	5
2. Definitions .....	5
3. Application for approval .....	6
4. Markings .....	7
5. Approval .....	7
6. Specifications .....	9
7. Modification and extension of approval of a vehicle type .....	11
8. Conformity of production .....	12
9. Penalties for non-conformity of production .....	13
10. Production definitely discontinued .....	13
11. Transitional provisions .....	13
12. Names and addresses of technical services responsible for conducting approval tests, and of administrative departments .....	14

ANNEXES

- Annex 1 - Communication concerning the approval or extension or refusal or withdrawal of approval or production definitely discontinued of a vehicle type with regard to its noise emission pursuant to Regulation No. 51
- Annex 2 - Arrangements of the approval mark
- Annex 3 - Methods and instruments for measuring the noise made by motor vehicles
- Annex 4 - Classification of vehicles
- Annex 5 - Exhaust systems containing fibrous materials

E/ECE/324  
E/ECE/TRANS/505 } Rev.1/Add.50/Rev.1  
Regulation No. 51  
page 4

Annex 6 - Compressed air noise

Annex 7 - Checks on conformity of production

Annex 8 - Specifications for the test site

---

1. SCOPE

This Regulation contains provisions relating to the noise emitted by motor vehicles having at least four wheels.

2. DEFINITIONS

For the purpose of this Regulation,

- 2.1. "Approval of a vehicle" means the approval of a vehicle type with regard to noise;
- 2.2. "Vehicle type" means a category of motor vehicles which do not differ in such essential respects as:
- 2.2.1. the shape or materials of the bodywork (particularly the engine compartment and its soundproofing);
- 2.2.2. the length and width of the vehicle;
- 2.2.3. the type of engine (positive or compression ignition, two- or four-stroke, reciprocating or rotary piston), number and capacity of cylinders, number and type of carburettors or injection system, arrangement of valves, rated maximum power and corresponding engine speed(s), or the type of electric motor;
- 2.2.4. the transmission system, the number of gears and ratios;
- 2.2.5. the noise reduction system as defined in the following paragraphs 2.3. and 2.4.
- 2.2.6. Notwithstanding the provisions of paragraphs 2.2.2. and 2.2.4., vehicles other than those in categories  $M_1$  and  $N_1$  1/ having the same type of engine and/or different overall gear ratios, may be regarded as vehicles of the same type.
- However, if the above differences provide for a different test method, these differences are to be considered as a change of type.
- 2.3. "Noise reduction system" means a complete set of components necessary for limiting the noise made by a motor vehicle and its exhaust;
- 2.4. "Noise reduction systems of different types" means noise reduction systems which differ in such essential respects as:

---

1/ In conformity with the definitions given in the Consolidated Resolution on the Construction of Vehicles (R.E.3) (TRANS/SC1/WP29/78/Amend.3, annex 7) (also reproduced in annex 4 to this Regulation).

- 2.4.1. that their components as specified in paragraph 4.1., bear different trade names or marks;
- 2.4.2. that the characteristics of the materials constituting a component are different or that the components differ in shape or size, a change in the plating procedure (galvanization, aluminium coating, etc.) is not deemed to produce a difference of type;
- 2.4.3. that the operating principles of at least one component are different;
- 2.4.4. that their components are assembled differently;
- 2.4.5. that the number of the intake and/or exhaust silencers is different.

2.5. "Noise reduction system component" means one of the individual constituent parts whose assembly constitutes the noise reduction system.

These components are, in particular: the exhaust pipings, the expansion chamber(s), the silencer(s) proper.

- 2.5.1. The air filter is considered as a component only if its presence is essential to ensure observance of the prescribed sound-level limits.
- 2.5.2. Manifolds are not considered components of the noise reduction system.

2.6. "Maximum mass" means the technically permissible maximum mass declared by the vehicle manufacturer (this mass may be greater than the maximum mass authorized by the national administration).

2.7. "Engine power" means the engine power expressed in kW (ECE) and measured by the ECE method pursuant to UN/ECE Regulation No. 85.

### 3. APPLICATION FOR APPROVAL

- 3.1. The application for approval of a vehicle type with regard to noise shall be submitted by its manufacturer or by his duly accredited representative.
- 3.2. It shall be accompanied by the undermentioned documents and the following particulars in triplicate:
  - 3.2.1. a description of the vehicle type with regard to the items mentioned in paragraph 2.2. above. The numbers and/or symbols identifying the engine type and the vehicle type shall be specified;

- 3.2.2. a list of the components, duly identified, constituting the noise reduction system;
- 3.2.3. a drawing of the assembled noise reduction system and an indication of its position on the vehicle;
- 3.2.4. detailed drawings of each component to enable it to be easily located and identified, and a specification of the materials used.
- 3.3. In the case of paragraph 2.2.6. the single vehicle, representative of the type in question, will be selected by the technical service conducting approval tests, in accordance with the vehicle manufacturer, as that with the lowest mass in running order with the shortest length and following the specification laid down in paragraph 3.1.2.3.2.3. in annex 3.
- 3.4. At the request of the technical service conducting approval tests, the vehicle manufacturer shall, in addition, submit a sample of the noise reduction system and an engine of at least the same cylinder capacity and rated maximum power as that fitted to the vehicle in respect of which type-approval is sought.
- 3.5. The competent authority shall verify the existence of satisfactory arrangements for ensuring effective control of the conformity of production before type approval is granted.
4. MARKINGS
  - 4.1. The components of the noise reduction system, excluding fixing hardware and piping, shall bear:
    - 4.1.1. the trade name or mark of the manufacturer of the noise reduction system and of its components; and
    - 4.1.2. the manufacturer's trade description;
    - 4.1.3. ECE - approval number.
  - 4.2. These markings shall be clearly legible and be indelible even after fitting.
  - 4.3. A component may carry several approval numbers if it has been approved as component of several replacement silencing systems.
5. APPROVAL
  - 5.1. If the vehicle type submitted for approval pursuant to this Regulation meets the requirements of paragraph 6. and 7. below, approval of that vehicle type shall be granted.

- 5.2. An approval number shall be assigned to each type approved. Its first two digits (at present 02 corresponding to the 02 series of amendments which entered into force on 18 April 1995) shall indicate the series of amendments incorporating the most recent major technical amendments made to the Regulation at the time of issue of the approval. The same Contracting Party may not assign the same number to the same vehicle type equipped with another type of noise reduction system or to another vehicle type.
- 5.3. Notice of approval or of extension or of refusal or withdrawal of approval or of production definitely discontinued of a vehicle type pursuant to this Regulation shall be communicated to the Parties to the Agreement applying this Regulation, by means of a form conforming to the model in annex 1 to this Regulation.
- 5.4. There shall be affixed, conspicuously and in a readily accessible place specified on the approval form, to every vehicle conforming to a vehicle type approved under this Regulation an international approval mark consisting of:
- 5.4.1. a circle surrounding the letter "E" followed by the distinguishing number of the country which has granted approval 2/;
- 5.4.2. the number of this Regulation, followed by the letter "R", a dash and the approval number to the right of the circle prescribed in paragraph 5.4.1.
- 5.5. If the vehicle conforms to a vehicle type approved, under one or more other Regulations annexed to the Agreement, in the country which has granted approval under this Regulation, the symbol prescribed in paragraph 5.4.1. need not be repeated; in such a case the regulation and approval numbers and the additional symbols of all the Regulations under which approval has been granted in the country which has granted approval under this Regulation shall be placed in vertical columns to the right of the symbol prescribed in paragraph 5.4.1.

---

2/ 1 for Germany, 2 for France, 3 for Italy, 4 for the Netherlands, 5 for Sweden, 6 for Belgium, 7 for Hungary, 8 for the Czech Republic, 9 for Spain, 10 for Yugoslavia, 11 for the United Kingdom, 12 for Austria, 13 for Luxembourg, 14 for Switzerland, 15 (vacant), 16 for Norway, 17 for Finland, 18 for Denmark, 19 for Romania, 20 for Poland, 21 for Portugal, 22 for the Russian Federation, 23 for Greece, 24 (vacant), 25 for Croatia, 26 for Slovenia, 27 for Slovakia, 28 for Belarus, 29 for Estonia, 30-36 (vacant) and 37 for Turkey. Subsequent numbers shall be assigned to other countries in the chronological order in which they ratify the Agreement concerning the Adoption of Uniform Conditions of Approval and Reciprocal Recognition of Approval for Motor Vehicle Equipment and Parts, or in which they accede to that Agreement, and the numbers thus assigned shall be communicated by the Secretary-General of the United Nations to the Contracting Parties to the Agreement.



- 5.6. The approval mark shall be clearly legible and be indelible.
- 5.7. The approval mark shall be placed close to or on the vehicle data plate affixed by the manufacturer.
- 5.8. Annex 2 to this Regulation gives examples of arrangements of the approval mark.
6. SPECIFICATIONS
- 6.1. General specifications
- 6.1.1. The vehicle, its engine and its noise reduction system shall be so designed, constructed and assembled as to enable the vehicle, in normal use, despite the vibration to which it may be subjected, to comply with the provisions of this Regulation.
- 6.1.2. The noise reduction system shall be so designed, constructed and assembled as to be able to reasonably resist the corrosive phenomena to which it is exposed having regard to the conditions of use of the vehicle.
- 6.2. Specifications regarding sound levels
- 6.2.1. Methods of measurement
- 6.2.1.1. The noise made by the vehicle type submitted for approval shall be measured by the two methods described in annex 3 to this Regulation for the vehicle in motion and for the vehicle when stationary 3/; in the case of a vehicle powered by an electric motor, the emitted noise shall only be measured in motion.
- Vehicles having a maximum permissible mass exceeding 2,800 kg must be subjected to an additional measurement of the compressed air noise with the vehicle stationary in accordance with the specifications of annex 6, if corresponding brake equipment is part of the vehicle.
- 6.2.1.2. The two values measured in accordance with the provisions of paragraph 6.2.1.1. above shall be entered in the test report and on a form conforming to the model in annex 1 to this Regulation.
- The values measured as specified in paragraph 6.2.1.1. above must be recorded in a test report and a certificate corresponding to the model shown in annex 1.

---

3/ A test is made on a stationary vehicle in order to provide a reference value for administrations which use this method to check vehicles in use.

6.2.2. Sound level limits

6.2.2.1. Subject to the provisions of paragraph 6.2.2.2. below, the sound level of vehicle types, as measured by the method described in paragraph 3.1. of annex 3 to this Regulation, shall not exceed the following limits:

Vehicle categories		Limit values (dB(A))
6.2.2.1.1.	Vehicles used for the carriage of passengers and capable of having not more than nine seats, including the driver's seat	74
6.2.2.1.2.	Vehicles used for the carriage of passengers having more than nine seats, including the driver's seat, and a maximum authorized mass of more than 3.5 tonnes	
6.2.2.1.2.1.	with an engine power less than 150 kW (ECE)	78
6.2.2.1.2.2.	with an engine power of 150 kW (ECE) or above	80
6.2.2.1.3.	Vehicles used for the carriage of passengers having more than nine seats, including the driver's seat; vehicles used for the carriage of goods	
6.2.2.1.3.1.	with a maximum authorized mass not exceeding 2 tonnes	76
6.2.2.1.3.2.	with a maximum authorized mass greater than 2 tonnes but not exceeding 3.5 tonnes	77
6.2.2.1.4.	Vehicles used for the transport of goods with a maximum authorized mass exceeding 3.5 tonnes	
6.2.2.1.4.1.	with an engine power less than 75 kW (ECE)	77
6.2.2.1.4.2.	with an engine power of 75 kW (ECE) or above but less than 150 kW (ECE)	78
6.2.2.1.4.3.	with an engine power of 150 kW (ECE) or above	80

- 6.2.2.2. However,
- 6.2.2.2.1. For the vehicle types mentioned in paragraphs 6.2.2.1.1. and 6.2.2.1.3. equipped with a compression-ignition and direct-injection internal combustion engine, the limit values shall be increased by 1 dB(A);
- 6.2.2.2.2. For vehicle types designed for off-road 4/ use and with a maximum authorized mass above 2 tonnes, the limit values shall be increased:
- 6.2.2.2.2.1. by 1 dB(A) if they are equipped with an engine having a power of less than 150 kW (ECE);
- 6.2.2.2.2.2. by 2 dB(A) if they are equipped with an engine having a power of 150 kW (ECE) or above.
- 6.2.2.2.3. For vehicle types mentioned in paragraph 6.2.2.1.1. fitted with a gear box having more than four forward gears and equipped with an engine developing a maximum power greater than 140 kW (ECE) and having a maximum-power/maximum-mass ratio greater than 75 kW/t, the limit values shall be increased by 1 dB(A), if the speed at which the rear of the vehicle passes the line BB' in third gear is greater than 61 km/h.
- 6.3. SPECIFICATIONS REGARDING EXHAUST SYSTEMS CONTAINING FIBROUS MATERIALS
- 6.3.1. Requirements of annex 5 shall be applied.
7. MODIFICATION AND EXTENSION OF APPROVAL OF A VEHICLE TYPE
- 7.1. Every modification of the vehicle type shall be notified to the administrative department which approved the vehicle type. The department may then either:
- 7.1.1. Consider that the modifications made are unlikely to have an appreciable adverse effect and that in any case the vehicle still complies with the requirements, or
- 7.1.2. Require a further test report from the technical service responsible for conducting the tests.
- 7.2. Confirmation or refusal of approval, specifying the alterations shall be communicated by the procedure specified in paragraph 5.3. above to the Parties to the Agreement applying this Regulation.

---

4/ As defined in annex 4 to this Regulation.

- 7.3. The competent authority issuing the extension of approval shall assign a series number for such an extension and inform thereof the other Parties to the 1958 Agreement applying this Regulation by means of a communication form conforming to the model in annex 1 to this Regulation.
8. CONFORMITY OF PRODUCTION
- 8.1. Vehicles approved to this Regulation shall be so manufactured as to conform to the type approved by meeting the requirements set forth in paragraph 6 above.
- 8.2. In order to verify that the requirements of paragraph 8.1. are met, suitable controls of the production shall be carried out.
- 8.3. The holder of the approval shall in particular
- 8.3.1. ensure existence of procedures for the effective control of the quality of products;
- 8.3.2. have access to the control equipment necessary for checking the conformity of each approved type;
- 8.3.3. ensure that data of test results are recorded and that annexed documents shall remain available for a period to be determined in accordance with the administrative service;
- 8.3.4. analyse the results of each type of test, in order to verify and ensure the stability of the product characteristics making allowance for variation of an industrial production;
- 8.3.5. ensure that for each type of product at least the tests prescribed in annex 7 to this Regulation are carried out;
- 8.3.6. ensure that any sampling or test pieces giving evidence of non-conformity with the type of test considered shall give rise to another sampling and another test. All the necessary steps shall be taken to re-establish the conformity of the corresponding production.
- 8.4. The competent authority which has granted type-approval may at any time verify the conformity control method applicable to each production unit.
- 8.4.1. In every inspection the test books and production survey records shall be presented to the visiting inspector.
- 8.4.2. The inspector may take samples at random which will be tested in the manufacturer's laboratory. The minimum number of samples may be determined according to the results of the manufacturer's own verification.

- 8.4.3. When the quality level appears unsatisfactory or when it seems necessary to verify the validity of the tests carried out in application of paragraph 8.4.2. the inspector shall select samples to be sent to the technical service which has conducted the type approval tests.
- 8.4.4. The competent authority may carry out any test prescribed in this Regulation.
- 8.4.5. The normal frequency of inspections by the competent authority shall be one every two years. If unsatisfactory results are recorded during one of these visits, the competent authority shall ensure that all necessary steps are taken to re-establish the conformity of production as rapidly as possible.
9. PENALTIES FOR NON-CONFORMITY OF PRODUCTION
- 9.1. The approval granted in respect of a vehicle type pursuant to this Regulation may be withdrawn if the requirements set forth above are not met.
- 9.2. If a Contracting Party to the Agreement applying this Regulation withdraws an approval it has previously granted, it shall forthwith so notify the other Contracting Parties applying this Regulation, by means of a communication form conforming to the model in annex 1 to this Regulation.
10. PRODUCTION DEFINITELY DISCONTINUED
- 10.1. If the holder of the approval completely ceases to manufacture a vehicle type approved in accordance with this Regulation, he shall so inform the authority which granted the approval. Upon receiving the relevant communication that authority shall inform thereof the other Parties to the 1958 Agreement applying this Regulation by means of a communication form conforming to the model in annex 1 to this Regulation.
11. TRANSITIONAL PROVISIONS
- 11.1. As from the official date of entry into force of the 02 series of amendments, no Contracting Party applying this Regulation shall refuse to grant ECE approval under this Regulation as amended by the 02 series of amendments.
- 11.2. As from 1 October 1995, Contracting Parties applying this Regulation shall grant ECE approvals only if the vehicle type to be approved meets the requirements of this Regulation as amended by the 02 series of amendments.

11.3. As from 1 October 1996, Contracting Parties applying this Regulation may refuse first national registration (first entry into service) of a vehicle which does not meet the requirements of the 02 series of amendments to this Regulation.

12. NAMES AND ADDRESSES OF TECHNICAL SERVICES RESPONSIBLE FOR CONDUCTING APPROVAL TESTS AND OF ADMINISTRATIVE DEPARTMENTS

The Parties to the 1958 Agreement applying this Regulation shall communicate to the United Nations Secretariat the names and addresses of the technical services responsible for conducting approval tests and of the administrative departments which grant approval and to which forms certifying approval or extension or refusal or withdrawal of approval, issued in other countries, are to be sent.

Annex 1  
 (Maximum format: A4 (210 x 297 mm))

COMMUNICATION



issued by: Name of administration:  
 .....  
 .....  
 .....

concerning: 2/ APPROVAL GRANTED  
 APPROVAL EXTENDED  
 APPROVAL REFUSED  
 APPROVAL WITHDRAWN  
 PRODUCTION DEFINITELY DISCONTINUED

of a vehicle type with regard to its noise emission pursuant to ECE Regulation No. 51.

Approval No.: ..... Extension No.: .....

1. Trade name or mark of the vehicle . . . . .
2. Vehicle type . . . . .
- 2.1. Maximum permissible mass including semi-trailer (where applicable) . . . . .
3. Manufacturer's name and address . . . . .
4. If applicable, name and address of manufacturer's representative . . . . .
5. Engine:
  - 5.1. Manufacturer: . . . . .
  - 5.2. Type: . . . . .
  - 5.3. Model: . . . . .
  - 5.4. Rated maximum power (ECE): ..... kW at ..... rev/min.
  - 5.5. Kind of engine: e.g. positive-ignition, compression ignition, etc. 3/  
 . . . . .
  - 5.6. Cycles: two stroke or four-stroke (if applicable) . . . . .
  - 5.7. Cylinder capacity (if applicable) . . . . .
6. Transmission: non-automatic gearbox/automatic gearbox 2/
  - 6.1. Number of gears . . . . .

7. Equipment:
- 7.1. Exhaust silencer: . . . . .
- 7.1.1. Manufacturer or authorized representative (if any) . . . . .  
 . . . . .
- 7.1.2. Model: . . . . .
- 7.1.3. Type: . . . . . in accordance with drawing No.: . . . . .
- 7.2. Intake silencer: . . . . .
- 7.2.1. Manufacturer or authorized representative (if any) . . . . .  
 . . . . .
- 7.2.2. Model: . . . . .
- 7.2.3. Type: . . . . . in accordance with drawing No.: . . . . .
- 7.3. Tyre size (by axle): . . . . .
8. Measurements:
- 8.1. Sound level of moving vehicle:

MEASUREMENT RESULTS			
	Left-hand side dB(A) <u>4</u> /	Right-hand side dB(A) <u>4</u> /	Position of gear lever
First measurement			
Second measurement			
Third measurement			
Fourth measurement			
Test result: . . . . .			dB(A)

- 8.2. Sound level of stationary vehicle:  
 Position and orientation of microphone (according to diagrams in  
 appendix of annex 3)

MEASUREMENT RESULTS		
	dB(A)	Engine speed
First measurement		
Second measurement		
Third measurement		
Test result: . . . . .		dB(A)



8.3. Sound level of compressed air noise:

MEASUREMENT RESULTS		
	Left-hand side dB(A) <u>4</u> /	Right-hand side dB(A) <u>4</u> /
First measurement		
Second measurement		
Third measurement		
Fourth measurement		
Test result: . . . . . dB(A)		

- 8.4. Ambient conditions
- 8.4.1. Test site (surface characteristics): . . . . .
- 8.4.2. Temperatures (in °C): . . . . .
- 8.4.2.1. Temperature of ambient air: . . . . .
- 8.4.2.2. Temperature of test track surface: . . . . .
- 8.4.3. Atmospheric pressure (kPa): . . . . .
- 8.4.4. Humidity (%): . . . . .
- 8.4.5. Wind speed (km/h): . . . . .
- 8.4.6. Wind direction: . . . . .
- 8.4.7. Background noise (dB(A)): . . . . .
9. Vehicle submitted for approval on: . . . . .
10. Technical service responsible for type-approval tests: . . . . .  
. . . . .
11. Date of test report issued by that service: . . . . .
12. Number of test report issued by that service: . . . . .
13. Type-approval in respect of sound levels is hereby  
granted/extended/refused/withdrawn 2/
14. Position of approval mark on the vehicle . . . . .
15. Place . . . . .
16. Date . . . . .
17. Signature . . . . .
18. The following documents, bearing the approval number shown above,  
are annexed to this communication:

drawings, diagrams and plans of the engine and of the noise  
reduction system;  
photographs of the engine and of the noise reduction system;  
list of components, duly identified constituting the noise  
reduction system.

19. Remarks:

. . . . .  
. . . . .  
. . . . .

- 
- 1/ Distinguishing number of the country which has granted/extended/refused/withdrawn approval (see approval provisions in the Regulations).
  - 2/ Strike out what does not apply.
  - 3/ If a non-conventional engine is used, this should be stated.
  - 4/ The measurement values are given with the 1 dB(A) deduction in accordance with the provisions of paragraph 6.2.2.1.
-

Annex 2

ARRANGEMENTS OF THE APPROVAL MARK

Model A

(See paragraph 5.4. of this Regulation)

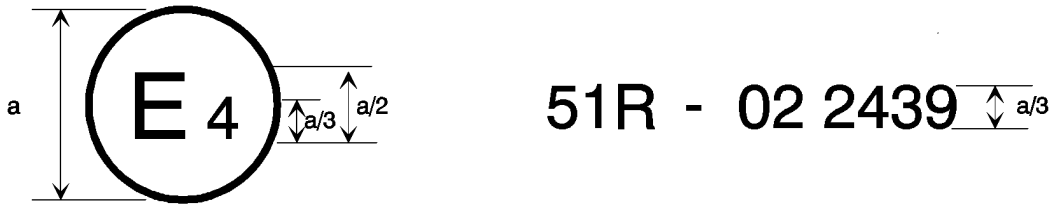

a = 8 mm min.

The above approval mark affixed to a vehicle shows that the vehicle type concerned has, with regard to its noise emission, been approved in the Netherlands (E 4) pursuant to Regulation No. 51 under approval No. 022439. The first two digits of the approval number indicate that Regulation No. 51 already included the 02 series of amendments when the approval was granted.

Model B

(See paragraph 5.5. of this Regulation)

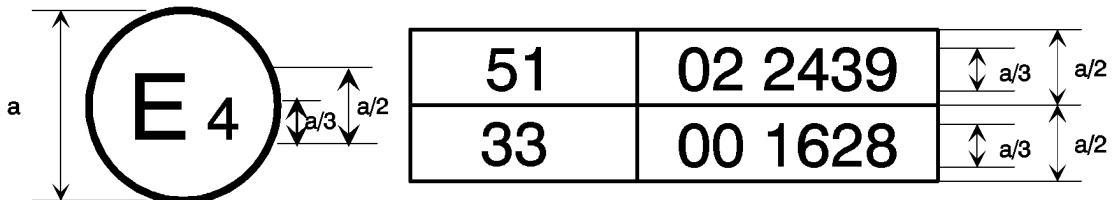

a = 8 mm min.

The above approval mark affixed to a vehicle shows that the vehicle type concerned has been approved in the Netherlands (E 4) pursuant to Regulations Nos. 51 and 33. <sup>1/</sup> The approval numbers indicate that, at the dates when the respective approvals were granted, Regulation No. 51 included the 02 series of amendments while Regulation No. 33 was in its original form.

---

<sup>1/</sup> The latter number is given as an example only.

---

### Annex 3

#### METHODS AND INSTRUMENTS FOR MEASURING THE NOISE MADE BY MOTOR VEHICLES

#### 1. MEASURING INSTRUMENTS

##### 1.1. Acoustic measurements

The apparatus used for measuring the noise level must be a precision sound-level meter of the type described in "Publication 651: Precision sound level meters", second edition, of the International Electrotechnical Commission (IEC). Measurements must be carried out using the "fast" response of the sound-level meter and the "A" weighting curve which are also described in that publication.

At the beginning and end of each set of measurements, the sound-level meter must be calibrated according to the manufacturer's instructions by means of an appropriate sound source (e.g. a pistonphone). The test must be considered invalid if the sound-level meter errors registered during this calibration exceed 1 dB. The actual deviation shall be stated in the approval document (annex 1).

##### 1.2. Speed measurements

The engine speed and vehicle speed on the test section shall be determined with an accuracy of 3% or better.

#### 2. CONDITIONS OF MEASUREMENT

##### 2.1. Site

##### 2.1.1. The test site must consist of a central acceleration section surrounded by a substantially flat test area.

The acceleration section must be level; the track surface must be dry and such that rolling noise remains low.

The test track must be such that the conditions of a free sound field between the sound source and the microphone are attained to within 1 dB. This condition shall be deemed to be met if there are no large sound-reflecting objects such as fences, rocks, bridges or building within 50 m of the centre of the acceleration section. The surface of the site must be in accordance with the provisions given in annex 8 to this Regulation and be free of powdery snow, tall grass, loose soil or cinders. There must be no obstacle which could affect the sound field within the vicinity of the microphone and the sound source. The observer carrying out the measurements must so position himself as not to affect the readings of the measuring instrument.

2.1.2. Measurements shall not be made under adverse weather conditions. It must be ensured that the results are not affected by gusts of wind.

Any sound peak which appears to be unrelated to the characteristics of the general sound level of the vehicle shall be ignored in taking the readings.

2.1.3. For measurements, the A-weighted sound level of sound sources other than those of the vehicle to be tested and of wind effects must be at least 10 dB(A) below the sound level produced by the vehicle. A suitable windscreen may be fitted to the microphone provided that account is taken of its effect on the sensitivity and directional characteristics of the microphone.

## 2.2. Vehicle

2.2.1. Measurements shall be made on unladen vehicles and, except in the case of non-separable vehicles, without trailer or semi-trailer.

2.2.2. The vehicle's tyres must be of the type normally fitted to such vehicle by the manufacturer and must be inflated to the appropriate pressure(s) for the unladen vehicle.

2.2.3. Before the measurements are started, the engine shall be brought to its normal operating conditions as regards:

2.2.3.1. temperatures

2.2.3.2. tuning

2.2.3.3. fuel

2.2.3.4. sparking plugs, carburettor(s), etc., (as appropriate).

2.2.4. If the vehicle is fitted with more than two-wheel drive, it shall be tested in the drive which is intended for normal road use.

2.2.5. If the vehicle is fitted with fan(s) having an automatic actuating mechanism, this system must not be interfered with during the measurements.

2.2.6. If the vehicle is equipped with an exhaust system containing fibrous materials, the exhaust system is to be conditioned before the test according to annex 5.

## 3. METHODS OF TESTING

### 3.1. Measurement of noise of vehicles in motion

3.1.1. General conditions of test (see appendix, fig. 1)

- 3.1.1.1. At least two measurements shall be made on each side of the vehicle. Preliminary measurements may be made for adjustment purposes, but shall be disregarded.
- 3.1.1.2. The microphone must be located at a distance of  $7.5 \pm 0.2$  m from the reference line CC' (Figure 1) of the track and  $1.2 \pm 0.1$  m above the ground. Its axis of maximum sensitivity must be horizontal and perpendicular to the path of the vehicle (line CC').
- 3.1.1.3. Two lines, AA' and BB', parallel to line PP' and situated respectively 10 m forward and 10 m rearward of that line shall be marked out on the test runway.

The vehicle shall be driven in a straight line over the acceleration section in such a way that the longitudinal median plane of the vehicle is as close as possible to the line CC' and approach line AA' at a steady speed as specified below. When the front of the vehicle reaches the line AA', the throttle shall be fully opened as rapidly as practicable and held in the fully-opened position until the rear of the vehicle crosses line BB'; the throttle shall then be closed again as rapidly as possible.

- 3.1.1.4. In the case of articulated vehicles consisting of two non-separable units regarded as a single vehicle, the semi-trailer shall be disregarded in determining when line BB' is crossed.
- 3.1.1.5. The maximum sound level expressed in A-weighted decibels (dB(A)) shall be measured as the vehicle is driven between lines AA' and BB'. Such value shall constitute the result of the measurement.

3.1.2. Determination of the approach speed

3.1.2.1. Symbols used

The letter symbols used in this paragraph have the following meaning:

S : engine rotation speed as indicated under item 5.4. of annex 1.

$N_A$ : uniform engine rotational speed at the approach of line AA'.

$V_A$ : uniform vehicle speed at the approach of line AA'.

$V_{max}$ : maximum speed declared by the vehicle manufacturer.

3.1.2.2. Vehicle with no gearbox

For vehicles with no gearbox or with no transmission control, the uniform speed at the approach of line AA' will be such that:

either  $V_A = 50 \text{ km/h}$ ;

or  $V_A$  corresponding to  $N_A = 3/4 S$  and  
 $V_A \leq 50 \text{ km/h}$

in the case of vehicles of category  $M_1$  and in the case of vehicles of categories other than  $M_1$ , having an engine power not greater than 225 kW (ECE);

or  $V_A$  corresponding to  $N_A = 1/2 S$  and  
 $V_A \leq 50 \text{ km/h}$

in the case of vehicles not belonging to category  $M_1$  having an engine power greater than 225 kW (ECE);

or, in the case of vehicles powered by an electric motor

$$V_A = \frac{3}{4} V_{\max} \quad \text{or} \quad V_A = 50 \text{ km/h},$$

whichever is the lower.

3.1.2.3. Vehicle with a manually-operated gearbox

3.1.2.3.1. Approach speed

The vehicle must approach the line AA' at a steady speed such that:

either  $V_A = 50 \text{ km/h}$ ;

or  $V_A$  corresponding to  $N_A = 3/4 S$  and  
 $V_A \leq 50 \text{ km/h}$

in the case of vehicles of category  $M_1$  and in the case of vehicles of categories other than  $M_1$ , having an engine power not greater than 225 kW (ECE);

or  $V_A$  corresponding to  $N_A = 1/2 S$  and  
 $V_A \leq 50 \text{ km/h}$

in the case of vehicles not belonging to category  $M_1$  having an engine power greater than 225 kW (ECE);

or, in the case of vehicles powered by an electric motor

$$V_A = \frac{3}{4} V_{\max} \quad \text{or} \quad V_A = 50 \text{ km/h,}$$

whichever is the lower.

3.1.2.3.2. Choice of the gear ratio

3.1.2.3.2.1. Vehicles of categories M<sub>1</sub> and N<sub>1</sub> 1/ fitted with a gearbox having four or less forward gears shall be tested in second gear.

3.1.2.3.2.2. Vehicles of categories M<sub>1</sub> and N<sub>1</sub> 1/ fitted with a gearbox having more than four forward gears shall be tested successively in second and third gear. The average value of the sound levels recorded for these two conditions shall be calculated.

However, vehicles of category M<sub>1</sub> having more than four forward gears and equipped with an engine developing a maximum power greater than 140 kW (ECE) and a permissible maximum-power/maximum-mass ratio greater than 75 kW (ECE)/t shall be tested only in third gear, provided that the speed at which the rear of the vehicle passes the line BB' in third gear is greater than 61 km/h.

If during the test in second gear, the engine speed exceeds the engine speed, S, at which the engine develops its rated maximum power, the test must be repeated with an approach speed and/or approach engine speed reduced by steps of 5 % S, until the engine speed attained no longer exceeds S.

3.1.2.3.2.3. Vehicles of categories other than M<sub>1</sub> and N<sub>1</sub> whose number of forward gears is x (including those obtained by way of an auxiliary transmission or a multi-gear axle) will be tested successively with the gear selection equal to or higher than x/n 2/ 3/.

---

1/ As defined in annex 4 to this Regulation.

2/ Where: n = 2 for vehicles having an engine power not greater than 225 kW (ECE):  
n = 3 for vehicles having an engine power greater than 225 kW (ECE).

3/ If x/n does not correspond to a whole number, the nearest higher ratio must be used.



The test result will be that obtained from the ratio producing the maximum sound level. Shifting up gears from x/n shall be terminated in that gear X where the engine speed S, at which the engine develops its rated maximum power is for the last time reached when passing the line BB'.

In case of vehicles having different overall gear ratios (including a different number of gears) the representative of the type by the test vehicle is determined as follows:

if the highest sound level is obtained between the gear ratios x/n and X the vehicle shall be deemed representative of its type;

if the highest sound level is obtained at ratio x/n the vehicle selected shall be deemed representative of its type only for those vehicles which have a lower overall gear ratio at x/n;

if the highest sound level is obtained at ratio X the vehicle selected shall be deemed representative of its type only for those vehicles which have a higher overall gear ratio at X.

3.1.2.4. Automatic transmission 4/

3.1.2.4.1. Vehicles without a manual selector

3.1.2.4.1.1. Approach speed

The vehicle shall approach the line AA' at various uniform speeds of 30, 40, 50 km/h or at 3/4 of the maximum on-road speed if this value is lower. The condition giving the highest noise level shall be retained.

3.1.2.4.2. Vehicles equipped with a manual selector with X positions

3.1.2.4.2.1. Approach speed

The vehicle must approach the line AA' at a steady speed such that:

either  $V_A = 50 \text{ km/h}$ ;

or  $V_A$  corresponding to  $N_A = 3/4 S$  and  $V_A \leq 50 \text{ km/h}$

---

4/ All vehicles equipped with automatic transmission.

in the case of vehicles of category  $M_1$  and in the case of vehicles of categories other than  $M_1$ , having an engine power not greater than 225 kW (ECE);

or  $V_A$  corresponding to  $N_A = 1/2 S$  and  
 $V_A \leq 50$  km/h

in the case of vehicles not belonging to category  $M_1$  having an engine power greater than 225 kW (ECE);

or, in the case of vehicles powered by an electric motor

$$V_A = \frac{3}{4} V_{\max} \quad \text{or} \quad V_A = 50 \text{ km/h,}$$

whichever is the lower.

3.1.2.4.2.2. Position of the manual selector

The test shall be conducted with the selector in the position recommended by the manufacturer for 'normal' driving. External downshifting (for example kickdown) shall be excluded.

3.1.2.4.2.3. Auxiliary gears

If the vehicle is fitted with an auxiliary manual transmission or a multi-gear axle, the position used for normal urban driving shall be used. In all cases, the special selector's positions for slow movements, parking, or braking shall be excluded.

3.1.3. INTERPRETATION OF RESULTS

The measurements of noise emitted by the vehicle in motion shall be considered valid if the difference between the two consecutive measurements on the same side of the vehicle is not more than 2 dB(A).

The figure recorded shall be that corresponding to the highest sound level. Should that figure exceed by more than 1 dB(A) the maximum sound level authorized for the category of vehicle tested, a second series of two measurements at the corresponding microphone position shall be made. Three out of the four results obtained in this position must fall within the prescribed limits.

To allow for lack of precision in the measuring instrument the figures read from it during measurement shall each be reduced by 1 dB(A).

3.2. Measurement of noise emitted by stationary vehicles

3.2.1. Sound level in the vicinity of vehicles

In order to facilitate subsequent checks on vehicles in use, the sound level must be measured close to the exhaust system outlet in accordance with the following requirements and the measurement results entered in the test report drawn up for the purpose of issuing the certificate referred to in annex 1.

3.2.2. Acoustic measurements

A precision sound level meter as defined in paragraph 1.1. of this annex must be used for the measurements.

3.2.3. Test site - local conditions (figure 2)

3.2.3.1. Measurements should be made on a stationary vehicle in an area which corresponds to that for measurements of vehicles in motion and therefore corresponds to the provisions given in annex 8 to this Regulation.

3.2.3.2. During the test nobody shall be in the measurement area, except the observer and the driver whose presence must have no influence on the metre reading.

3.2.4. Disturbance noise and wind interference

Readings on the measuring instruments produced by ambient noise and wind must be at least 10 dB(A) below the sound level to be measured. A suitable windscreen may be fitted to the microphone provided that account is taken of its effect on the sensitivity of the microphone.

3.2.5. Measuring method

3.2.5.1. Nature and number of measurements

The maximum sound level expressed in A-weighted decibels (dB(A)) must be measured during the operating period referred to in paragraph 3.2.5.3.2.1.

At least three measurements must be taken at each measuring point.

3.2.5.2. Positioning and preparation of the vehicle

The vehicle shall be located in the centre part of the test area with the gear level in neutral position and the clutch engaged. If the design of the vehicle does not allow this, the vehicle shall be tested in conformity with the manufacturer's prescriptions for stationary engine testing. Before each series of measurements, the engine must be brought to its normal operating condition, as specified by the manufacturer.

If the vehicle is fitted with fan(s) having an automatic actuating mechanism, this system shall not be interfered with during the sound level measurements.

3.2.5.3. Measuring of noise in proximity to the exhaust  
(see appendix, fig. 2)

3.2.5.3.1. Positions of the microphone

3.2.5.3.1.1. The height of the microphone above the ground should be equal to that of the outlet pipe of the exhaust gases, but in any event shall be limited to a minimum value of 0.2 m.

3.2.5.3.1.2. The microphone must be pointed towards the orifice of the gas flow and located at a distance of 0.5 m from the latter.

3.2.5.3.1.3. Its axis of maximum sensitivity must be parallel to the ground and must make an angle of  $45^{\circ} \pm 10^{\circ}$  with the vertical plane containing the direction of the gas flow. The instructions of the manufacturer of the sound level meter with regard to this axis must be respected. In relation to this plane, the microphone shall be placed in such a way as to obtain the maximum distance from the longitudinal median plane of the vehicle; in case of doubt, the position which gives the maximum distance from the contour of the vehicle shall be selected.

3.2.5.3.1.4. In the case of an exhaust provided with two or more outlets spaced less than 0.3 m apart and which are connected to the same silencer, only one measurement is made; the microphone position is related to the outlet nearest to one extreme edge of the vehicle or, when such outlet does not exist, to the outlet which is the highest above the ground.

3.2.5.3.1.5. For vehicles with a vertical exhaust (e.g. commercial vehicles) the microphone should be placed at the height of the exhaust outlet. Its axis should be vertical and oriented upwards. It should be placed at a distance of 0.5 m from the side of the vehicle nearest to the exhaust.

- 3.2.5.3.1.6. For vehicles having an exhaust provided with outlets spaced more than 0.3 m apart, one measurement is made for each outlet as if it were the only one, and the highest level is noted.
- 3.2.5.3.2. Operating conditions of the engine
- 3.2.5.3.2.1. The engine is operated at a constant speed having the following value: 3/4 S for both controlled ignition engines and for diesel engines.
- 3.2.5.3.2.2. When constant engine speed is reached, the throttle shall be returned swiftly to the idle position. The sound level shall be measured during a period of operation consisting of a brief maintenance of constant engine speed and throughout the entire deceleration period, the maximum sound level meter reading being taken as the test value.
- 3.2.6. Results
- 3.2.6.1. Readings, rounded off to the nearest decibel, shall be taken from the measuring instrument.
- Only those values obtained from three consecutive measurements which do not differ by more than 2 dB(A) respectively will be taken into consideration.
- 3.2.6.2. The highest of these three values shall constitute the test result.
-

Annex 3 - Appendix  
 Measuring positions for vehicles in motion

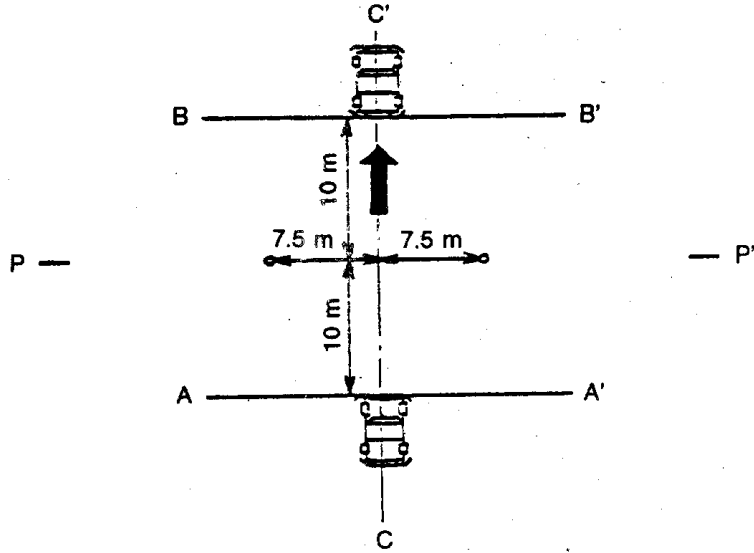

Fig.1

Measuring positions for stationary vehicles  
 (examples)

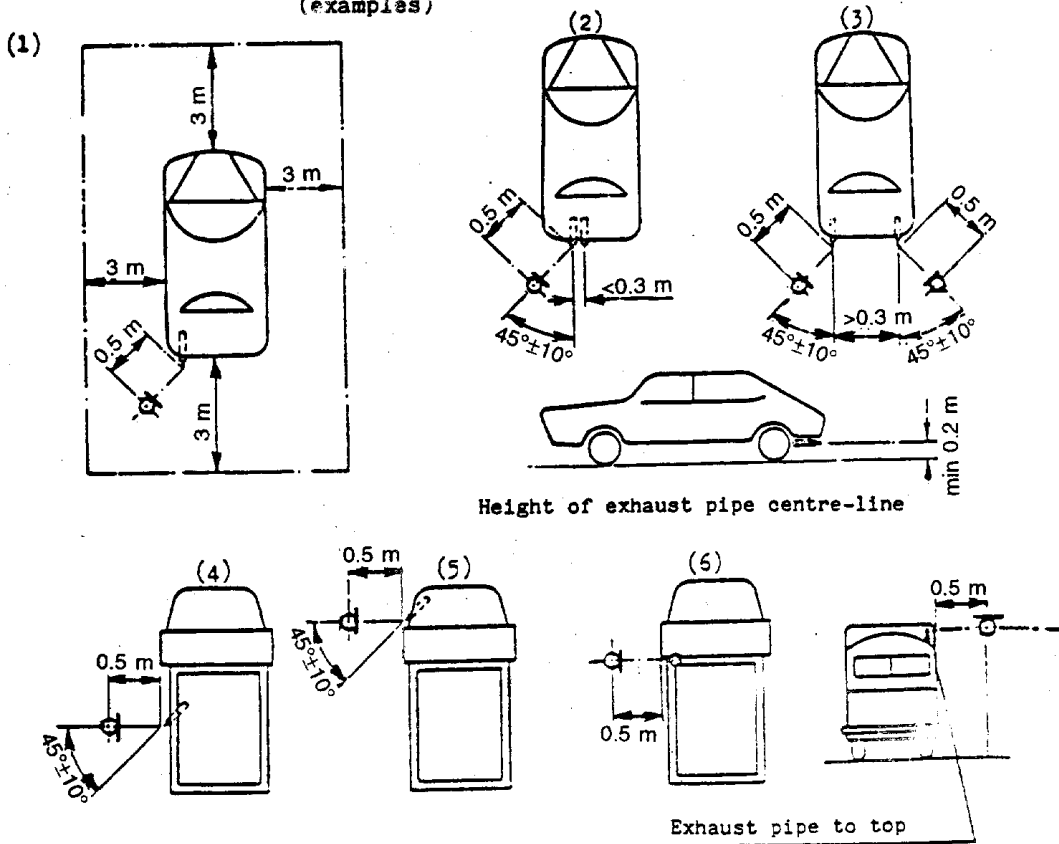

Fig.2

Annex 4

CLASSIFICATION OF VEHICLES 1/

1. CATEGORY L  
(Not applicable for this Regulation)
2. CATEGORY M - POWER-DRIVEN VEHICLES HAVING AT LEAST FOUR WHEELS AND USED FOR THE CARRIAGE OF PASSENGERS
  - 2.1. Category M<sub>1</sub>: Vehicles used for the carriage of passengers and comprising not more than eight seats in addition to the driver's seat.
  - 2.2. Category M<sub>2</sub>: Vehicles used for the carriage of passengers, comprising more than eight seats in addition to the driver's seat, and having a maximum mass not exceeding 5 tonnes.
  - 2.3. Category M<sub>3</sub>: Vehicles used for the carriage of passengers, comprising more than eight seats in addition to the driver's seat, and having a maximum mass exceeding 5 tonnes.
  - 2.4. Vehicles of categories M<sub>2</sub> and M<sub>3</sub> belong to one of the three following classes:
    - 2.4.1. Class I 'city-bus': a vehicle of this class has seats, and spaces for standing passengers.
    - 2.4.2. Class II 'interurban bus or coach': a vehicle of this class may have provision for standing passengers, but only in the gangway.
    - 2.4.3. Class III 'touring coach': a vehicle of this class has no provisions to carry standing passengers.
  - 2.5. Remarks
    - 2.5.1. 'Articulated bus or coach' is a vehicle which consists of two or more rigid sections which articulate relative to one another; the passenger compartments of each section intercommunicate so that passengers can move freely between them; the rigid sections are permanently connected so that they can only be separated by an operation involving facilities which are normally only found in a workshop.

---

1/ In conformity with the Consolidated Resolution on the Construction of Vehicles (R.E.3) (TRANS/SC1/WP29/78/Amend.3, annex 7).

- 2.5.2. Articulated buses or coaches comprising two or more non-separable but articulated units shall be considered as single vehicles.
- 2.5.3. In the case of a towing vehicle designed to be coupled to a semi-trailer (tractor for semi-trailer), the mass to be considered for classifying the vehicle is the mass of the tractor vehicle in running trim, increased by the mass corresponding to the maximum static vertical load transferred to the tractor vehicle by the semi-trailer and, where applicable, by the maximum mass of the tractor vehicle's own load.
3. CATEGORY N - POWER-DRIVEN VEHICLES HAVING AT LEAST FOUR WHEELS AND USED FOR THE CARRIAGE OF GOODS.
- 3.1. Category N<sub>1</sub>: Vehicles used for the carriage of goods and having a maximum mass not exceeding 3.5 tonnes.
- 3.2. Category N<sub>2</sub>: Vehicles used for the carriage of goods and having a maximum mass exceeding 3.5 tonnes but not exceeding 12 tonnes.
- 3.3. Category N<sub>3</sub>: Vehicles used for the carriage of goods and having a maximum mass exceeding 12 tonnes.
- 3.4. Remarks
- 3.4.1. In the case of a towing vehicle designed to be coupled to a semi-trailer (tractor for semi-trailer), the mass to be considered for classifying the vehicle is the mass of the tractor vehicle in running trim, increased by the mass corresponding to the maximum static vertical load transferred to the tractor vehicle by the semi-trailer and, where applicable, by the maximum mass of the tractor vehicle's own load.
- 3.4.2. The equipment and installations carried on certain special-purpose vehicles (crane vehicles, workshop vehicles, publicity vehicles, etc.) are regarded as being equivalent to goods.
-



Annex 5

EXHAUST SYSTEMS CONTAINING FIBROUS MATERIALS

1. Fibrous materials shall not be used in the construction of silencers unless suitable measures are undertaken at the design or production stages to ensure that the efficiency required to comply with the limits imposed in paragraph 6.2.2. of this Regulation is achieved on the road. Such a silencer shall be considered to be efficient on the road if the exhaust gases are not in contact with the fibrous materials or if the silencer of the prototype vehicle tested in accordance with the requirements of paragraphs 3.1 and 3.2. of this Regulation has been put into a normal state for road use before the sound-level measurements are taken. This can be achieved by using one of the three tests described in paragraphs 1.1., 1.2. and 1.3. below or by removing the fibrous materials from the silencer.
  - 1.1. Continuous road operation for 10,000 km
    - 1.1.1. About half this operation consists of town driving and the other half of long-distance runs at high speed; continuous road operation can be replaced by a corresponding test-track programme.
    - 1.1.2. The two speed régimes should be alternated on several occasions.
    - 1.1.3. The complete test programme must include a minimum of 10 breaks of at least three hours duration in order to reproduce the effects of cooling and any condensation which may occur.
  - 1.2. Conditioning on a test bench
    - 1.2.1. Using standard parts and observing the vehicle manufacturer's instructions, the silencer must be fitted to the engine, which is coupled to a dynamometer.
    - 1.2.2. The test must be conducted in six six-hour periods with a break of at least 12 hours between each period in order to reproduce the effects of cooling any condensation which may occur.
    - 1.2.3. During each six-hour period, the engine shall be run, under the following conditions in turn:
      - (1) Five minutes at idling speed;
      - (2) One-hour sequence under 1/4 load at 3/4 of rated maximum speed (S);

- (3) One-hour sequence under 1/2 load at 3/4 of rated maximum speed (S);
- (4) 10-minute sequence under full load at 3/4 of rated maximum speed (S);
- (5) 15-minute sequence under 1/2 load at rated maximum speed (S);
- (6) 30-minute sequence under 1/4 load at rated maximum speed (S).

Total duration of the six sequences: three hours.

Each period must comprise two sets of the six above-mentioned sequences.

1.2.4. During the test, the silencer must not be cooled by a forced draught simulating normal airflow around the vehicle. Nevertheless, at the request of the manufacturer, the silencer may be cooled in order not to exceed the temperature recorded at its inlet when the vehicle is running at maximum speed.

1.3. Conditioning by pulsation

1.3.1. The exhaust system or components thereof must be fitted to the vehicle referred to in paragraph 3.3. of this Regulation or the engine referred to in paragraph 3.4. of this Regulation. In the former case the vehicle must be mounted on a roller dynamometer.

In the second case, the engine must be mounted on a dynamometer. The test apparatus, a detailed diagram of which is shown in Figure 3 of the appendix to this annex must be fitted at the outlet of the exhaust system. Any other apparatus providing equivalent results is acceptable.

1.3.2. The test apparatus must be adjusted in a such a way that the exhaust-gas flow is alternatively interrupted and re-established by the quick-action valve for 2,500 cycles.

1.3.3. The valve must open when the exhaust-gas back pressure, measured at least 100 mm downstream of the intake flange, reaches a value of between 0.35 and 0.40 bar. It must close when this pressure does not differ by more than 10% from its stabilized value with the valve open.

1.3.4. The time-delay switch shall be set for the duration of gas exhaust resulting from the provisions laid down in paragraph 1.3.3. above.

1.3.5. Engine speed must be 75% of the speed (S) at which the engine develops maximum power.

1.3.6. The power indicated by the dynamometer must be 50% of the full-throttle power measured at 75% of engine speed (S).

1.3.7. Any drainholes must be closed off during the test.

1.3.8. The entire test must be completed within 48 hours.

If necessary, one cooling period will be observed after each hour.

---

Annex 5 - Appendix

Figure 3

Test apparatus for conditioning  
 by pulsation

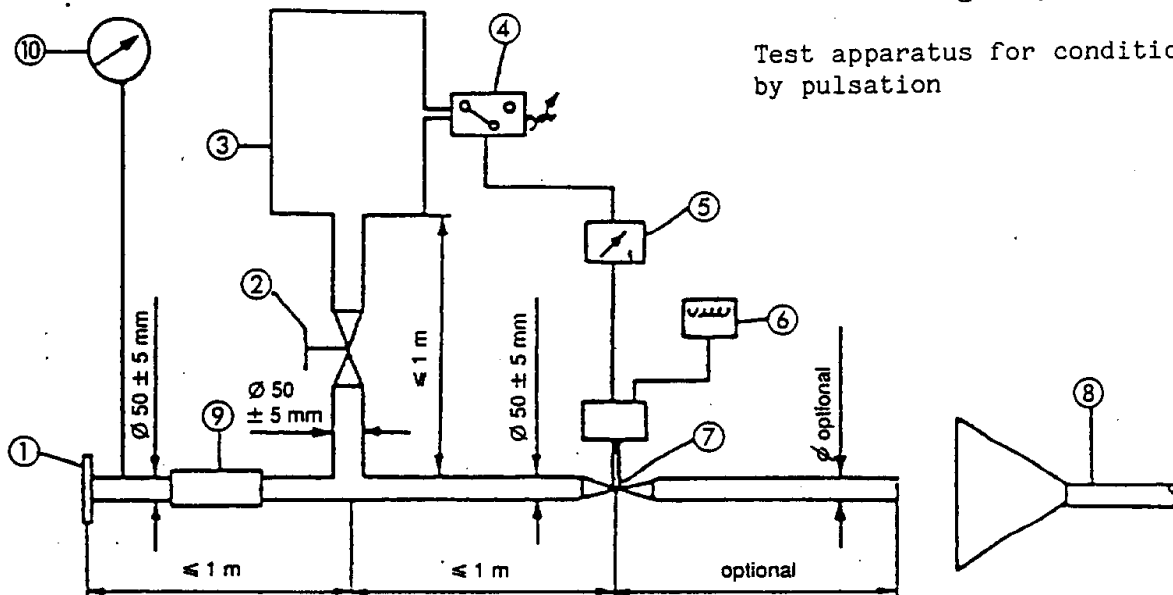

1. Inlet flange or sleeve for connection to the rear of the test exhaust system.
2. Hand-operated regulating valve.
3. Compensating reservoir with a maximum capacity of 40 l and a filling time of not less than one second.
4. Pressure switch with an operating range of 0.05 to 2.5 bar.
5. Time delay switch.
6. Pulse counter.
7. Quick-acting valve, such as exhaust brake valve 60 mm in diameter, operated by a pneumatic cylinder with an output of 120 N at 4 bar. The response time, both when opening and closing, must not exceed 0.5 second.
8. Exhaust gas evacuation.
9. Flexible pipe.
10. Pressure gauge.

Annex 6

COMPRESSED AIR NOISE

1. Method of measurement

The measurement is performed at microphone positions 2 and 6 according to Figure 1, with the vehicle stationary. The highest A-weighted noise level is registered during venting the pressure regulator and during ventilating after the use of both the service and parking brakes.

The noise during venting the pressure regulator is measured with the engine at idling speed. The ventilating noise is registered while operating the service and parking brakes; before each measurement, the air-compressor unit has to be brought up to the highest permissible operating pressure, and then the engine switched off.

2. Evaluation of the results

For all microphone positions two measurements are taken. In order to compensate for inaccuracies of the measuring equipment, the metre reading is reduced by 1 dB(A), and the reduced value is taken as the result of measurement. The results are taken as valid if the difference between the measurements at one microphone position does not exceed 2 dB(A). The highest value measured is taken as the result. If this value exceeds the noise limit by 1 dB(A), two additional measurements are to be taken at the corresponding microphone position. In this case, three out of the four results of measurement obtained at this position have to comply with the noise limit.

3. Limiting value

The sound level shall not exceed the limit of 72 dB(A).

---

Annex 6 - Appendix

Figure 1: Microphone positions for measurement of compressed air noise

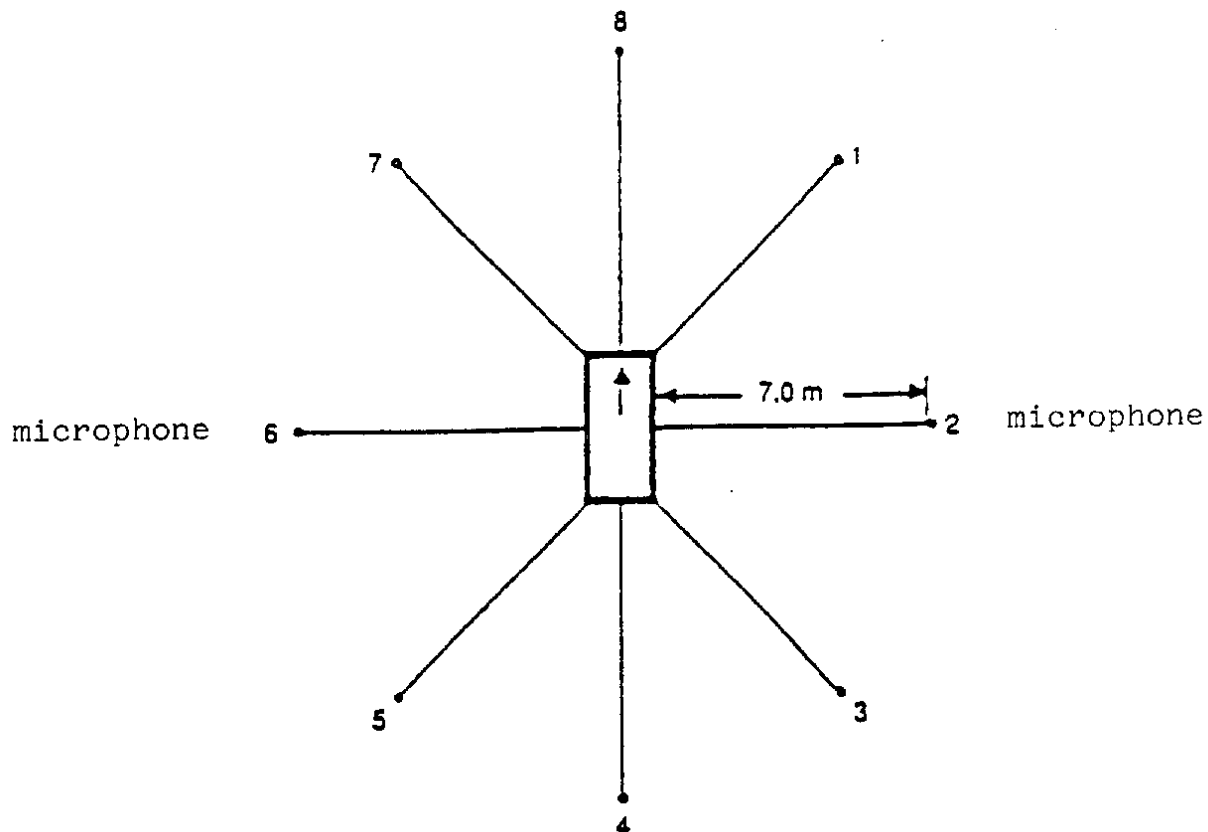

The measurement is performed at the stationary vehicle according to Figure 1, using two microphone positions at a distance of 7 m from the contour of the vehicles, and at 1.2 m above ground.

---

Annex 7

CHECKS ON CONFORMITY OF PRODUCTION

1. General

These requirements are consistent with the test to be held to check conformity of production according to paragraphs 8.3.5. and 8.4.3. of this Regulation.

2. Testing procedure

The test site and measuring instruments shall be those as described in annex 3.

2.1. The vehicle(s) under test shall be subjected to the test for measurement of noise of vehicle in motion as described in paragraph 3.1. of annex 3.

2.2. Compressed air noise

Vehicles having maximum mass exceeding 2,800 kg and equipped with compressed air systems must be subjected to an additional test for measurement of the compressed air noise as described in paragraph 1 of annex 6.

3. Sampling

One vehicle has to be chosen. If after the test of paragraph 4.1. the vehicle is not considered to conform to the requirements of this Regulation, two more vehicles have to be tested.

4. Evaluation of the results

4.1. If the sound level of the vehicle tested pursuant to paragraphs 1 and 2 does not exceed by more than 1 dB(A) the limit value prescribed in paragraph 6.2.2. of this Regulation, for measurement according to paragraph 2.1. above, and in paragraph 3 of annex 6 to this Regulation, for measurement according to paragraph 2.2. above, the vehicle type shall be considered to conform to the requirements of this Regulation.

4.2. If the vehicle tested according to paragraph 4.1. does not satisfy the requirements laid down in that paragraph, two more vehicles of the same type have to be tested pursuant to paragraphs 1 and 2.

4.3. If the sound level of the second and/or third vehicle of paragraph 4.2. exceeds by more than 1 dB(A) the limit values prescribed in paragraph 6.2.2. of this Regulation, the vehicle type shall be considered not to conform to the requirements of this Regulation and the manufacturer shall take the necessary measures to re-establish the conformity.

---

## Annex 8

### SPECIFICATIONS FOR THE TEST SITE

#### 1. Introduction

This annex describes the specifications relating to the physical characteristics and the laying of the test track. These specifications based on a special standard 1/ describe the required physical characteristics as well as the test methods for these characteristics.

#### 2. Required characteristics of the surface

A surface is considered to conform to this standard provided that the texture and voids content or sound absorption coefficient have been measured and found to fulfil all the requirements of paragraphs 2.1. to 2.4. below and provided that the design requirements (para. 3.2.) have been met.

##### 2.1. Residual voids content

The residual voids content,  $V_c$ , of the test track paving mixture shall not exceed 8%. For the measurement procedure, see paragraph 4.1.

##### 2.2. Sound absorption coefficient

If the surface fails to comply with the residual voids content requirement, the surface is acceptable only if its sound absorption coefficient,  $\alpha \leq 0.10$ . For the measurement procedure, see para. 4.2. The requirement of paragraphs 2.1. and 2.2. is met also if only sound absorption has been measured and found to be  $\alpha \leq 0.10$ .

Note: The most relevant characteristic is the sound absorption, although the residual voids content is more familiar among road constructors. However, sound absorption needs to be measured only if the surface fails to comply with the voids requirement. This is motivated because the latter is connected with relatively large uncertainties in terms of both measurements and relevance and some surfaces therefore erroneously may be rejected when based only on the voids measurement.

##### 2.3. Texture depth

The texture depth (TD) measured according to the volumetric method (see paragraph 4.3. below) shall be:

$$TD \geq 0.4 \text{ mm}$$

---

1/ ISO 10844:1994.



#### 2.4. Homogeneity of the surface

Every practical effort shall be taken to ensure that the surface is made to be as homogeneous as possible within the test area. This includes the texture and voids content, but it should also be observed that if the rolling process results in more effective rolling at some places than others, the texture may be different and unevenness causing bumps may also occur.

#### 2.5. Period of testing

In order to check whether the surface continues to conform to the texture and voids content or sound absorption requirements stipulated in this standard, periodic testing of the surface shall be done at the following intervals:

- (a) For residual voids content or sound absorption:

when the surface is new;

if the surface meets the requirements when new, no further periodical testing is required. If it does not meet the requirement when it is new, it may do later because surfaces tend to become clogged and compacted with time.

- (b) For texture depth (TD):

when the surface is new;

when the noise testing starts (NB: not before four weeks after laying);

then every twelve months.

### 3. Test surface design

#### 3.1. Area

When designing the test track layout it is important to ensure that, as a minimum requirement, the area traversed by the vehicles running through the test strip is covered with the specified test material with suitable margins for safe and practical driving. This will require that the width of the track is at least 3 m and the length of the track extends beyond lines AA and BB by at least 10 m at either end. Figure 1 shows a plan of a suitable test site and indicates the minimum area which shall be machine laid and machine compacted with the specified test surface material. According to annex 3, paragraph 3.1.1.1., measurements have to be made on each side of the vehicle. This can be made either by measuring with two microphone locations (one on each side of the track) and driving in one direction, or measuring with a microphone only on one side of the track but driving the vehicle in two directions. If the latter method is used, then there are no surface requirements on that side of the track where there is no microphone.

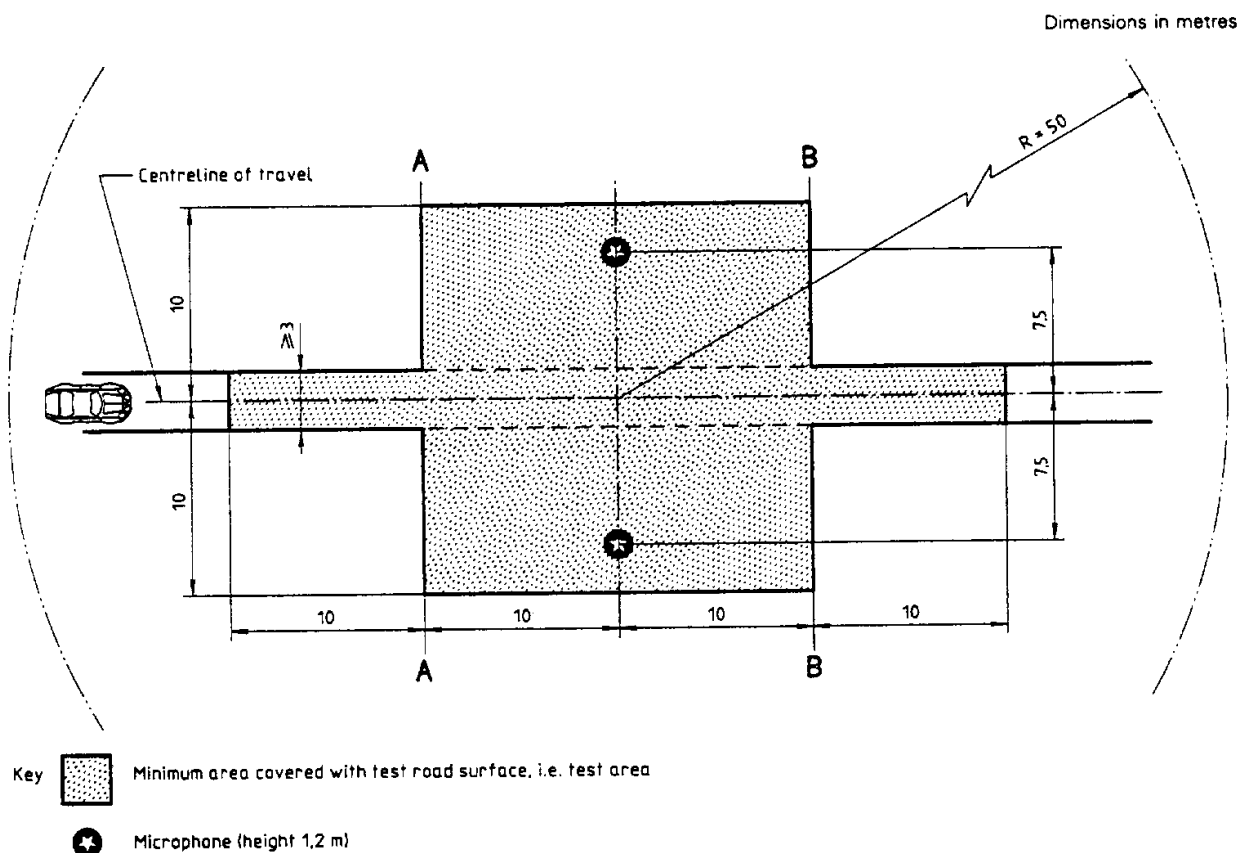

NOTE — There shall be no large acoustically reflective objects within this radius.

Figure 1: Minimum requirement for test surface area. The shaded part is called "Test Area".

3.2. Design and preparation of the surface

3.2.1. Basic design requirements

The test surface shall meet four design requirements:

3.2.1.1. It shall be a dense asphaltic concrete.

3.2.1.2. The maximum chipping size shall be 8 mm (tolerances allow from 6.3 to 10 mm).

3.2.1.3. The thickness of the wearing course shall be  $\geq 30$  mm.

3.2.1.4. The binder shall be a straight penetration grade bitumen without modification.

3.2.2. Design guidelines

As a guide to the surface constructor, an aggregate grading curve which will give desired characteristics is shown in Figure 2. In addition, Table 1 gives some guidelines in order to obtain the desired texture and durability. The grading curve fits the following formula:

$$P (\% \text{ passing}) = 100 \cdot (d/d_{\max})^{1/2}$$

where:

- d = square mesh sieve size, in mm
- d<sub>max</sub> = 8 mm for the mean curve
- d<sub>max</sub> = 10 mm for the lower tolerance curve
- d<sub>max</sub> = 6.3 mm for the upper tolerance curve

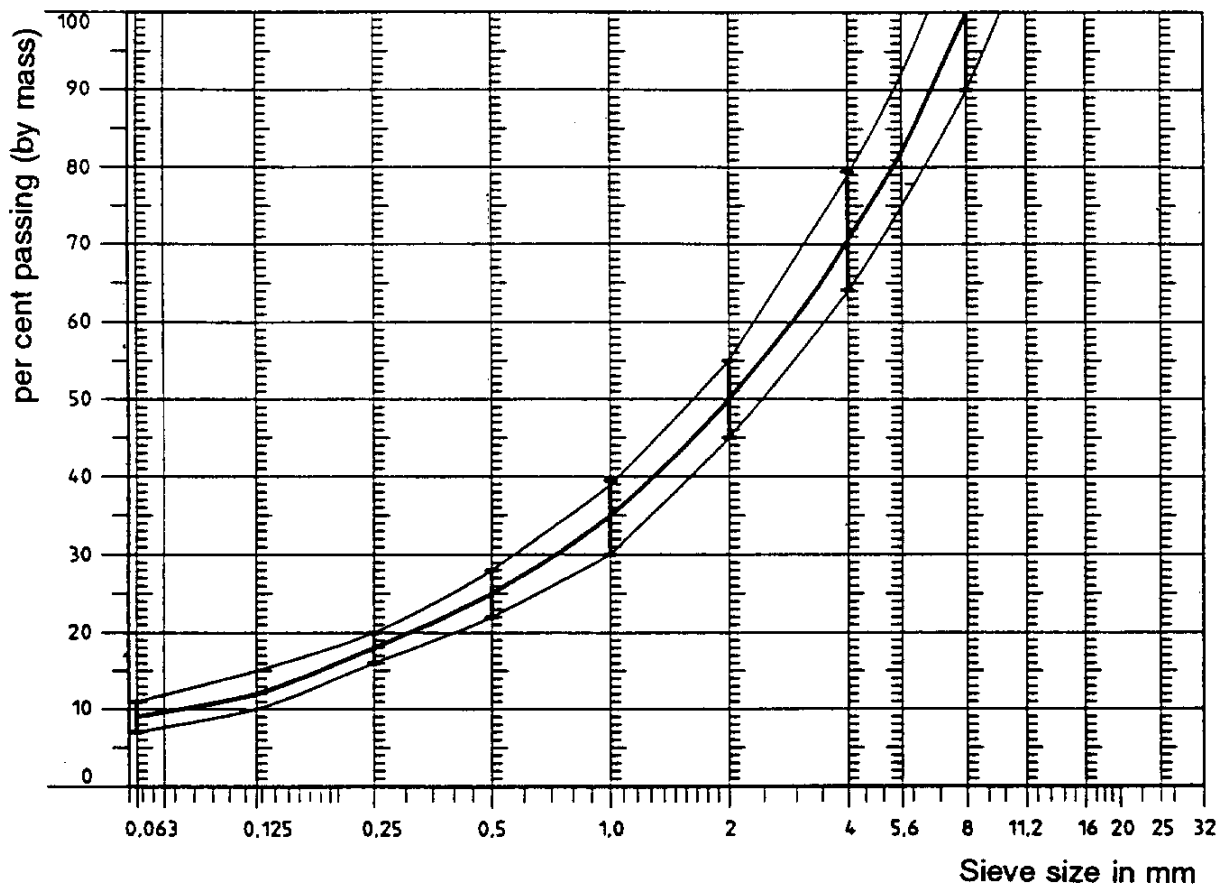

Figure 2: Grading curve of the aggregate in the asphaltic mix with tolerances.

In addition to the above, the following recommendations are given:

- (a) The sand fraction (0.063 mm < square mesh sieve size < 2 mm) shall include no more than 55% natural sand and at least 45% crushed sand;
- (b) The base and sub-base shall ensure a good stability and evenness, according to best road construction practice;
- (c) The chippings shall be crushed (100% crushed faces) and of a material with a high resistance to crushing;
- (d) The chippings used in the mix shall be washed;
- (e) No extra chippings shall be added onto the surface;
- (f) The binder hardness expressed as PEN value shall be 40-60, 60-80 or even 80-100 depending on the climatic conditions of the country. The rule is that as hard a binder as possible shall be used, provided this is consistent with common practice;
- (g) The temperature of the mix before rolling shall be chosen so as to achieve by subsequent rolling the required voids content. In order to increase the probability of satisfying the specifications of paragraphs 2.1. to 2.4. above, the compactness shall be studied not only by an appropriate choice of mixing temperature, but also by an appropriate number of passings and by the choice of compacting vehicle.

Table 1: Design guidelines

	Target values		Tolerances
	By total mass of mix	By mass of the aggregate	
Mass of stones, square mesh sieve (SM) > 2 mm	47.6 %	50.5 %	± 5
Mass of sand 0.063 < SM < 2 mm	38.0 %	40.2 %	± 5
Mass of filler SM < 0.063 mm	8.8 %	9.3 %	± 2
Mass of binder (bitumen)	5.8 %	N.A.	± 0.5
Max. chipping size		8 mm	6.3 - 10
Binder hardness	(see para. 3.2.2. (f))		
Polished stone value (PSV)		> 50	
Compactness, relative to Marshall compactness		98 %	

#### 4. Test method

##### 4.1. Measurement of the residual voids content

For the purpose of this measurement, cores have to be taken from the track in at least four different positions which are equally distributed in the test area between lines AA and BB (see Figure 1). In order to avoid inhomogeneity and unevenness in the wheel tracks, cores should not be taken in wheel tracks themselves, but close to them. Two cores (minimum) should be taken close to the wheel tracks and one core (minimum) should be taken approximately midway between the wheel tracks and each microphone location.

If there is a suspicion that the condition of homogeneity is not met (see paragraph 2.4.), cores shall be taken from more locations within the test area.

The residual voids content has to be determined for each core, then the average value from all cores shall be calculated and compared with the requirement of paragraph 2.1. In addition, no single core shall have a voids value which is higher than 10%. The test surface constructor is reminded of the problem which may arise when the test area is heated by pipes or electrical wires and cores must be taken from this area. Such installations must be carefully planned with respect to future core drilling locations. It is recommended to leave a few locations of size approximately 200 x 300 mm where there are no wires/pipes or where the latter are located deep enough in order not to be damaged by cores taken from the surface layer.

##### 4.2. Sound absorption coefficient

The sound absorption coefficient (normal incidence) shall be measured by the impedance tube method using the procedure specified in ISO 10534-1: "Acoustics - Determination of sound absorption coefficient and impedance by a tube method." 2/

Regarding test specimens, the same requirements shall be followed as regarding the residual voids content (see paragraph 4.1.). The sound absorption shall be measured in the range between 400 Hz and 800 Hz and in the range between 800 Hz and 1,600 Hz (at least at the centre frequencies of third octave bands) and the maximum values shall be identified for both of these frequency ranges. Then these values, for all test cores, shall be averaged to constitute the final result.

---

2/ To be published.

4.3. Volumetric macrotexture measurement

For the purpose of this standard, texture depth measurements shall be made on at least 10 positions evenly spaced along the wheel tracks of the test strip and the average value taken to compare with the specified minimum texture depth. See the draft ISO 10844:1994 for description of the procedure.

5. Stability in time and maintenance

5.1. Age influence

In common with any other surfaces, it is expected that the tyre/road noise level measured on the test surface may increase slightly during the first 6-12 months after construction.

The surface will achieve its required characteristics not earlier than four weeks after construction. The influence of age on the noise from trucks is generally less than that from cars.

The stability over time is determined mainly by the polishing and compaction by vehicles driving on the surface. It shall be periodically checked as stated in paragraph 2.5.

5.2. Maintenance of the surface

Loose debris or dust which could significantly reduce the effective texture depth must be removed from the surface. In countries with winter climates, salt is sometimes used for de-icing. Salt may alter the surface temporarily or even permanently in such a way as to increase noise and is therefore not recommended.

5.3. Repaving the test area

If it is necessary to repave the test track, it is usually unnecessary to repave more than the test strip (of 3 m width in Figure 1) where vehicles are driving, provided the test area outside the strip met the requirement of residual voids content or sound absorption when it was measured.

6. Documentation of the test surface and of tests performed on it

6.1. Documentation of the test surface

The following data shall be given in a document describing the test surface:

6.1.1. The location of the test track.

6.1.2. Type of binder, binder hardness, type of aggregate, maximum theoretical density of the concrete ( $D_R$ ), thickness of the wearing

course and grading curve determined from cores from the test track.

- 6.1.3. Method of compaction (e.g. type of roller, roller mass, number of passes).
- 6.1.4. Temperature of the mix, temperature of the ambient air and wind speed during laying of the surface.
- 6.1.5. Date when the surface was laid and contractor.
- 6.1.6. All or at least the latest test result, including:
  - 6.1.6.1. The residual voids content of each core.
  - 6.1.6.2. The locations in the test area from where the cores for voids measurements have been taken.
  - 6.1.6.3. The sound absorption coefficient of each core (if measured). Specify the results both for each core and each frequency range as well as the overall average.
  - 6.1.6.4. The locations in the test area from where the cores for absorption measurement have been taken.
  - 6.1.6.5. Texture depth, including the number of tests and standard deviation.
  - 6.1.6.6. The institution responsible for tests according to paragraphs 6.1.6.1. and 6.1.6.2. and the type of equipment used.
  - 6.1.6.7. Date of the test(s) and date when the cores were taken from the test track.
- 6.2. Documentation of vehicle noise tests conducted on the surface

In the document describing the vehicle noise test(s) it shall be stated whether all the requirements of this standard were fulfilled or not. Reference shall be given to a document according to paragraph 6.1. describing the results which verify this.

---