

AGREEMENT

CONCERNING THE ADOPTION OF UNIFORM CONDITIONS OF APPROVAL AND RECIPROCAL RECOGNITION OF APPROVAL FOR MOTOR VEHICLE EQUIPMENT AND PARTS

done at Geneva on 20 March 1958

Addendum 42: Regulation No. 43

Revision 1

Incorporating the amendments* which entered into force on 31 March 1987

UNIFORM PROVISIONS CONCERNING THE APPROVAL OF SAFETY GLAZING AND GLAZING MATERIAL

*Supplement 3 to this Regulation in its original form. This supplement does not require any change in the approval number.



UNITED NATIONS

Regulation No. 43

UNIFORM PROVISIONS CONCERNING THE APPROVAL OF SAFETY GLAZING AND
GLAZING MATERIAL

CONTENTS

	<u>Page</u>
REGULATION	
1. Scope	1
2. Definitions	1
3. Application for approval	3
4. Markings	4
5. Approval	4
6. General requirements	5
7. Particular requirements	6
8. Tests	6
9. Modification or extension of approval of a type of safety- glass pane	10
10. Conformity of production	10
11. Penalties for non-conformity of production	11
12. Transitional provisions	11
13. Production definitely discontinued	11
14. Names and addresses of technical services responsible for conducting approval tests, and of administrative departments	12

Table of contents (cont'd)

ANNEXES

- Annex 1 - Communication concerning approval (or extension or refusal or withdrawal of approval or production definitely discontinued) of a type of safety-glass pane pursuant to Regulation No. 43
 - Annex 2 - Arrangements of approval marks
 - Annex 3 - General test conditions
 - Annex 4 - Toughened-glass windscreens
 - Annex 5 - Uniformly-toughened glass panes
 - Annex 6 - Ordinary laminated-glass windscreens
 - Annex 7 - Laminated-glass panes other than windscreens
 - Annex 8 - Treated laminated-glass windscreens
 - Annex 9 - Safety-glass panes faced with plastics material (on the inside)
 - Annex 10 - Glass-plastics windscreens
 - Annex 11 - Glass-plastics panes other than windscreens
 - Annex 12 - Double-glazed units
 - Annex 13 - Grouping of windscreens for approval testing
 - Annex 14 - Measurement of the height of segment and position of the points of impact
 - Annex 15 - Procedure for determining test areas on windscreens of M₁ category vehicles in relation to the 'V' points
 - Annex 16 - Procedure for determining the 'H' point and the actual torso angle for seating positions in motor vehicles
 - Annex 17 - Checks on conformity of production
-

Regulation No. 43

UNIFORM PROVISIONS CONCERNING THE APPROVAL OF
SAFETY GLAZING AND GLAZING MATERIALS

1. SCOPE

- 1.1. This Regulation applies to safety glazing and glazing materials intended for installation as windscreens or other panes, or as partitioning, on power-driven vehicles and their trailers, to the exclusion however of glass panes for lighting and light-signalling devices and instrument panels, of special bullet-proof and aggression-resistant glass panes, and of materials other than glass.

This Regulation does not concern the installation of safety glazing and glazing materials on power-driven vehicles and their trailers or double windows.

2. DEFINITIONS

For the purpose of this Regulation :

- 2.1. "Toughened-glass pane" means a glass pane consisting of a single layer of glass which has been subjected to special treatment to increase its mechanical strength and to condition its fragmentation after shattering;
- 2.2. "Laminated-glass pane" means a glass pane consisting of two or more layers of glass held together by one or more interlayers of plastics material; it may be :
- 2.2.1. "ordinary", when none of the layers of glass of which it is composed has been treated; or
- 2.2.2. "treated", when at least one of the layers of glass of which it is composed has been specially treated to increase its mechanical strength and to condition its fragmentation after shattering;
- 2.3. "Safety-glass pane faced with plastics material" means a glass pane as defined in 2.1. or 2.2. with a layer of plastics material on its inner face;
- 2.4. "Glass-plastics pane" means a pane of laminated glass having one layer of glass and one or more layers of plastics material, at least one of which acts as interlayer. The plastics layer(s) shall be on the inner face when the glazing is fitted on the vehicle;
- 2.5. "Group of windscreens" means a group comprising windscreens of differing sizes and shapes subjected to an examination of their mechanical properties, their mode of fragmentation and their behaviour in environmental-aggression resistance tests;
- 2.5.1. "flat windscreen" means a windscreen exhibiting no nominal curvature resulting in a height of segment greater than 10 mm per linear metre;
- 2.5.2. "curved windscreen" means a windscreen exhibiting a nominal curvature resulting in a height of segment greater than 10 mm per linear metre;

- 2.6. "Double window" means an assembly of two glass panes separately installed within the same opening of the vehicle;
- 2.7. "Double-glazed unit" means an assembly of two glass panes permanently assembled in manufacture and separated by a uniform gap;
- 2.7.1. "Symmetrical double-glazing" means a double-glazed unit where the two component glass panes are of the same type (toughened, laminated, etc.) and have the same principal and secondary characteristics;
- 2.7.2. "Asymmetrical double-glazing" means a double-glazed unit where the two component glass panes are of different type (toughened, laminated, etc.) or have different principal and/or secondary characteristics;
- 2.8. "Principal characteristic" means a characteristic which appreciably modifies the optical and/or mechanical properties of a glass pane in a way not without significance to the function which the glass pane is to perform in a vehicle. This term also covers the trade name or mark;
- 2.9. "Secondary characteristic" means a characteristic capable of modifying the optical and/or mechanical properties of a glass pane in a way which is of significance to the function which the glass pane is intended to perform in a vehicle. The extent of such modification is assessed in relation to the indices of difficulty;
- 2.10. The term "Indices of difficulty" covers a two-stage grading system applying to the variations observed in practice in each secondary characteristic. A change from index '1' to index '2' indicates the need for additional tests;
- 2.11. "Developed area of a windscreen" means the minimum rectangular area of glass from which a windscreen can be manufactured;
- 2.12. "Inclination angle of a windscreen" means the angle included between on the one hand a vertical line and on the other hand a straight line passing through the top and bottom edges of the windscreen, both lines being contained in a vertical plane containing the longitudinal axis of the vehicle;
- 2.12.1. Measurement of the inclination angle shall be performed on a vehicle standing on level ground, and in the case of a passenger-transport vehicle the vehicle shall be in running order, shall be fully charged with fuel, coolant and lubricant, and shall be equipped with tools and the spare wheel or wheels (if they are provided as standard equipment by the vehicle manufacturer); allowance shall be made for the mass of the driver, and also, in the case of a passenger-transport vehicle, for that of one front-seat passenger, the mass of the driver and that of the passenger each being deemed to be 75 ± 1 kg;
- 2.12.2. Vehicles equipped with hydropneumatic, hydraulic or pneumatic suspension or with a device for automatic adjustment of ground clearance according to load shall be tested in the normal running conditions specified by the manufacturer;
- 2.13. "Height of segment 'h'" means the maximum distance, measured at right angles approximately to the glass pane, separating the inner surface of the pane from a plane passing through the ends of the pane (see annex 14, figure 1);
- 2.14. "Type of glass pane" means glass panes as defined in paragraphs 2.1. to 2.4. not exhibiting any essential differences, with respect, in particular, to the principal and secondary characteristics defined in annexes 4 to 12;

- 2.14.1. Although a change in the principal characteristics implies that the product is of a new type, it is recognized that in certain cases a change in shape and dimension does not necessarily require a complete set of tests to be carried out. For certain of the tests prescribed in the individual annexes, glass panes may be grouped if it is evident that they have similar principal characteristics;
- 2.14.2. Glass panes exhibiting differences only as regards their secondary characteristics may be deemed to be of the same type; certain tests may however be carried out on samples of such panes if the performance of those tests is explicitly stipulated in the test conditions;
- 2.15. "curvature 'r'" means the approximate value of the smallest radius of arc of the windscreen as measured in the most curved area.

3. APPLICATION FOR APPROVAL

- 3.1. The application for approval of a type of glass pane shall be submitted by the manufacturer of the safety-glass pane or by his duly accredited representative in the country where the application is made.
- 3.2. For each type of safety-glass pane the application shall be accompanied by the undermentioned documents in triplicate and by the following particulars:
- 3.2.1. a technical description comprising all principal and secondary characteristics, and
- 3.2.1.1. in the case of glass panes other than windscreens, diagrams in a format not exceeding A4 or folded to that format showing :
- the maximum area,
the smallest angle between two adjacent sides of the glass pane,
the greatest height of segment, where applicable.
- 3.2.1.2. in the case of windscreens,
- 3.2.1.2.1. a list of the models of windscreens for which approval is sought, specifying the name of the vehicle manufacturer and the type and category of the vehicle.
- 3.2.1.2.2. drawings on a scale 1:1 for M₁ category and 1:1 or 1:10 for all other categories, and diagrams of the windscreen and its positioning in the vehicle in sufficient detail to show :
- 3.2.1.2.2.1. the position of the windscreen relative to the R point of the driver's seat, where applicable,
- 3.2.1.2.2.2. the inclination angle of the windscreen,
- 3.2.1.2.2.3. the inclination angle of the seat-back,
- 3.2.1.2.2.4. the position and size of the zones in which the optical qualities are verified and, where appropriate, the area subjected to differential toughening,
- 3.2.1.2.2.5. the developed area of the windscreen,
- 3.2.1.2.2.6. the maximum height of segment of the windscreen,
- 3.2.1.2.2.7. the curvature of the windscreen (for windscreen-grouping purposes only).

3.2.1.3: In the case of double-glazed units, diagrams in a format not exceeding A4 or folded to that format, showing, in addition to the information referred to in paragraph 3.2.1.1. :

the type of each component glass pane,
the type of sealing (organic, glass to glass/glass to metal),
the nominal width of the gap between the two glass panes.

3.3. In addition, the applicant for approval shall submit a sufficient number of test pieces and samples of the finished glass panes of the models considered, the number being if necessary determined by agreement with the technical service responsible for conducting the tests.

3.4. The competent authority shall verify the existence of satisfactory arrangements for ensuring effective control of conformity of production before type approval is granted.

4. MARKINGS

4.1. Every safety-glass pane, including the samples and test pieces submitted for approval, shall bear the trade name or mark of the manufacturer. The marking shall be clearly legible and indelible.

5. APPROVAL

5.1. If the samples submitted for approval meet the requirements of paragraphs 6 to 8 of this Regulation, approval of the pertinent type of safety-glass pane shall be granted.

5.2. An approval number shall be assigned to each type as defined in annex 5, 7, 11 and 12 or, in the case of windscreens, to each group approved. Its first two digits (at present 00 for the Regulation in its original form) shall indicate the series of amendments incorporating the most recent major technical amendments made to the Regulation at the time of issue of the approval. The same Contracting Party may not assign the same number to another type or group of safety-glass panes.

5.3. Notice of approval or extension of approval or refusal of approval of a type of safety-glass pane pursuant to this Regulation shall be communicated to the Parties to the Agreement applying this Regulation, by means of a form conforming to the model in annex 1 - and its appendices - to this Regulation.

5.3.1. In the case of windscreens, the notice of approval shall be accompanied by a document listing every windscreen model in the approved group, together with the characteristics of the group pursuant to annex 1, appendix 8.

5.4. There shall be affixed conspicuously to every safety-glass pane and double-glazed unit conforming to a type approved under this Regulation, in addition to the marking prescribed in paragraph 4.1., an international approval mark.
Any specific approval mark assigned to each pane forming a double-glazed unit may also be affixed.

This approval mark shall consist of :

- 5.4.1. a circle surrounding the letter 'E' followed by the distinguishing number of the country which has granted approval 1/;
- 5.4.2. the number of this Regulation, followed by the letter 'R', a dash and the approval number to the right of the circle prescribed in paragraph 5.4.1.
- 5.5. The following additional symbols shall be affixed near the above approval mark :
 - 5.5.1. in the case of a windscreen :
 - I. for toughened glass (I/P if faced) 2/
 - II. for ordinary laminated glass (II/P if faced) 2/
 - III. for treated laminated glass (III/P if faced) 2/
 - IV. for glass-plastics glazing.
 - 5.5.2. V. in the case of a glass-pane other than a windscreen covered by the provisions of annex 3, paragraph 9.1.4.2..
 - 5.5.3. VI. in the case of a double-glazed unit
 - 5.5.4. VII. in the case of uniformly-toughened glass panes which can be used as windscreens for slow-moving vehicles which, by construction, cannot exceed 30 km/h.
- 5.6. The approval mark and symbol shall be clearly legible and be indelible.
- 5.7. Annex 2 to this Regulation gives examples of arrangements of approval marks.

6. GENERAL REQUIREMENTS

- 6.1. All glass, including glass for the manufacture of windscreens, shall be such that, in the event of shattering, the danger of bodily injury is reduced as far as possible. The glass shall be sufficiently resistant to the incidents likely to occur in normal traffic, and to atmospheric and temperature conditions, chemical action, combustion and abrasion.
- 6.2. Safety glass shall in addition be sufficiently transparent, shall not cause any noticeable distortions of objects as seen through the windscreen, and shall not give rise to any confusion between the colours used in road-traffic signs and signals. In the event of the windscreen's shattering, the driver must still be able to see the road clearly enough to be able to brake and stop his vehicle safely.

1/ 1 for the Federal Republic of Germany, 2 for France, 3 for Italy, 4 for the Netherlands, 5 for Sweden, 6 for Belgium, 7 for Hungary, 8 for Czechoslovakia, 9 for Spain, 10 for Yugoslavia, 11 for the United Kingdom, 12 for Austria, 13 for Luxembourg, 14 for Switzerland, 15 for the German Democratic Republic, 16 for Norway, 17 for Finland, 18 for Denmark, 19 for Romania, 20 for Poland, 21 for Portugal, and 22 for the Union of Soviet Socialist Republics. Subsequent numbers shall be assigned to other countries in the chronological order in which they ratify or accede to the Agreement concerning the Adoption of Uniform Conditions of Approval and Reciprocal Recognition of Approval for Motor Vehicle Equipment and Parts, and the numbers thus assigned shall be communicated by the Secretary-General of the United Nations to the Contracting Parties to the Agreement.

2/ As defined in paragraph 2.3

7. PARTICULAR REQUIREMENTS

All types of safety glass shall, depending on the category to which they belong, comply with the following particular requirements

- 7.1. as regards toughened-glass windscreens, the requirements contained in annex 4;
- 7.2. as regards uniformly-toughened glass panes, the requirements contained in annex 5;
- 7.3. as regards ordinary laminated-glass windscreens, the requirements contained in annex 6;
- 7.4. as regards ordinary laminated-glass panes other than windscreens, the requirements contained in annex 7;
- 7.5. as regards treated laminated-glass windscreens, the requirements contained in annex 8;
- 7.6. as regards safety-glass panes faced with plastics material, in addition to the relevant requirements listed above, the requirements contained in annex 9;
- 7.7. as regards glass-plastics windscreens, the requirements contained in annex 10;
- 7.8. as regards glass-plastics panes other than windscreens, the requirements contained in annex 11;
- 7.9. as regards double-glazed units, the requirements contained in annex 12.

8. TESTS

8.1. The following tests are prescribed in this Regulation :

8.1.1. Fragmentation test

The purpose of this test is :

- 8.1.1.1. to verify that the fragments and splinters produced by fracture of the glass pane are such as to minimize the risk of injury, and
- 8.1.1.2. in the case of windscreens, to check residual visibility after shattering.

8.1.2. Mechanical strength test

8.1.2.1. Ball-impact test

There are two forms of tests, one using a 227 g ball and one using a 2,260 g ball.

- 8.1.2.1.1. - 227 g ball test : The purpose of this test is to assess the adhesion of the interlayer of laminated glass and the mechanical strength of uniformly-toughened glass.
- 8.1.2.1.2. - 2,260 g ball test : The purpose of this test is to assess ball-penetration resistance of laminated glass.

8.1.2.2. Hendform test

The purpose of this test is to verify the glass pane's compliance with requirements relating to the limitation of injury in the event of impact of the head against the windscreen, against laminated-glass panes or glass-plastics panes other than windscreens, or against double-glazed units used in side windows.

8.1.3. Test of resistance to the environment

8.1.3.1. Test of resistance to abrasion

The purpose of this test is to determine whether the resistance of a safety-glass pane to abrasion exceeds a specified value.

8.1.3.2. Test of resistance to high temperature

The purpose of this test is to verify that no bubbles or other defects occur in the interlayer in laminated glass or glass-plastics glazing when exposed to high temperatures over an extended period of time.

8.1.3.3. Resistance-to-radiation test

The purpose of this test is to determine whether the light transmittance of laminated-glass panes, glass-plastics panes or glass panes faced with plastics material when exposed to radiation over an extended period of time is significantly reduced thereby or whether the glazing is significantly discoloured.

8.1.3.4. Resistance-to-humidity test

The purpose of this test is to determine whether laminated-glass panes, glass-plastics panes or glass panes faced with plastics material will withstand, without significant deterioration, the effects of prolonged exposure to atmospheric humidity.

8.1.3.5. Resistance-to-temperature-changes test

The purpose of this test is to check that plastics material(s) used in safety glazing as defined in paragraphs 2.3. and 2.4. above will withstand the effects of prolonged exposure to extremes of temperature without significant deterioration.

8.1.4. Optical qualities

8.1.4.1. Light-transmission test

The purpose of this test is to determine whether the regular transmittance of safety-glass panes exceeds a specified value.

8.1.4.2. Optical-distortion test

The purpose of this test is to verify that the distortion of objects as seen through the windscreen is not of such extent as to be likely to confuse the driver.

8.1.4.3. Secondary-image-separation test

The purpose of this test is to verify that the angular separation of the secondary image from the primary image does not exceed a specified value.

8.1.4.4. Identification-of-colours test

The purpose of this test is to verify that there is no risk of confusion of colours as seen through a windscreen.

8.1.5. Burning-behaviour (fire-resistance) test

The purpose of this test is to verify that the inner face of a safety-glass pane as defined in paragraphs 2.3. and 2.4. above has a sufficiently low burn rate.

8.1.6. Test of resistance to chemicals

The purpose of this test is to determine that the inner face of a safety-glass pane as defined in paragraphs 2.3. and 2.4. above will withstand the effects of exposure to chemicals likely to be normally present or used within the vehicle (e.g. cleaning compounds) without significant deterioration.

8.2. Tests prescribed for glass panes of the categories defined in paragraphs 2.1. to 2.4. of this Regulation

8.2.1. Safety-glass panes shall be subjected to the tests listed in the following table (see on page 9).

8.2.2. A safety-glass pane shall be approved if it meets all the requirements prescribed in the relevant provisions referred to in the following table (see on page 9).

8.2.1. TABLE

Tests	Windscreens										Glass panes other than windscreens		
	Toughened glass		Ordinary laminated glass		Treated laminated glass		Glass-plastics		Toughened glass	Laminated glass	Glass-plastics		
	I	I-P	II	II-P	III	III-P	IV						
Fragmentation :	A4/2	A4/2	-	-	A8/4	A8/4	-	-	A5/2	-	-		
Mechanical strength :	-	-	A6/4.3	A6/4.3	A6/4.3	A6/4.3	A6/4.3	A6/4.3	A5/3.1	A7.4	A7.4		
227 g ball	-	-	A6/4.2	A6/4.2	A6/4.2	A6/4.2	A6/4.2	A6/4.2	-	-	-		
2,260 g ball	-	-	A6/3	A6/3	A6/3	A6/3	A6/3	A6/3	-	A7/3	A11/3		
Headform test 1/	A4/3	A4/3	-	-	-	-	-	-	-	-	-		
Abrasion:	-	-	A6/5.1	A6/5.1	A6/5.1	A6/5.1	A6/5.1	A6/5.1	-	A6/5.1	A6/5.1		
Outer face	-	-	A9/2	A9/2	-	A9/2	A9/2	A9/2	A9/2 2/	A9/2 2/	A9/2		
Inner face	-	-	A3/5	A3/5	A3/5	A3/5	A3/5	A3/5	-	A3/5	A3/5		
High temperature:	-	-	A3/6	A3/6	A3/6	A3/6	A3/6	A3/6	-	A3/6	A3/6		
Radiation :	-	-	A3/7	A3/7	A3/7	A3/7	A3/7	A3/7	A3/7 2/	A3/7	A3/7		
Humidity :	-	-	-	-	-	-	-	-	-	-	-		
Light transmission :	A3/9.1	A3/9.1	A3/9.1	A3/9.1	A3/9.1	A3/9.1	A3/9.1	A3/9.1	A3/9.1	A3/9.1	A3/9.1		
Optical distortion :	A3/9.2	A3/9.2	A3/9.2	A3/9.2	A3/9.2	A3/9.2	A3/9.2	A3/9.2	A3/9.2 2/	-	-		
Secondary image :	A3/9.3	A3/9.3	A3/9.3	A3/9.3	A3/9.3	A3/9.3	A3/9.3	A3/9.3	A3/9.3 2/	-	-		
Identification of colours :	A3/9.4	A3/9.4	A3/9.4	A3/9.4	A3/9.4	A3/9.4	A3/9.4	A3/9.4	-	-	-		
Resistance to temperature changes :	-	A3/8	-	A3/8	-	A3/8	A3/8	A3/8	A3/8 2/	A3/8 2/	A3/8		
Fire resistance:	-	A3/10	-	A3/10	-	A3/10	A3/10	A3/10	A3/10 2/	A3/10 2/	A3/10		
Resistance to chemicals :	-	A3/11	-	A3/11	-	A3/11	A3/11	A3/11	A3/11 2/	A3/11 2/	A3/11		

1/ Furthermore this test shall be carried out on double-glazed units pursuant to annex 12, paragraph 3 (A12/3)
 2/ If coated on the inner side with plastics material.
 3/ This test shall only be carried out on uniformly-toughened glass-panes to be used as windscreens of slow-moving vehicles which, by construction, cannot exceed 30 km/h.

NOTE : A reference such as A4/3 in the table indicates the annex (4) and paragraph (3) of that annex, where the relevant test is described and the acceptance requirements are specified.

9. MODIFICATION OR EXTENSION OF APPROVAL OF A TYPE OF SAFETY-GLASS PANE

9.1. Every modification of a type of safety-glass pane, or in the case of windscreens every addition of a windscreen to a group, shall be notified to the administrative department which approved the type of safety-glass pane. The department may then either :

9.1.1. consider that the modifications made are unlikely to have an appreciable adverse effect and, in the case of windscreens, that the new type comes within the approved group of windscreens, and that in any case the safety-glass pane still complies with the requirements; or

9.1.2. require a further test report from the technical service responsible for conducting the tests.

9.2. Communication

9.2.1. Confirmation or refusal of approval (or extension of approval) shall be communicated by the procedure specified in paragraph 5.3. above to the Parties to the Agreement applying this Regulation.

9.2.2. The competent Authority which has granted an extension of approval shall enter a serial number on each communication of extension.

10. CONFORMITY OF PRODUCTION

10.1. Safety glazing approved under this Regulation shall be so manufactured as to conform to the type approved by meeting the requirements set out in paragraphs 6, 7 and 8 above.

10.2. To verify that the requirements of paragraph 10.1. above have been met, appropriate checks on production shall be carried out.

10.3. The holder of the approval shall in particular :

10.3.1. ensure that procedures exist for effective quality control of the product,

10.3.2. have access to the equipment necessary for checking conformity to each approved type,

10.3.3. record data of test results and make the annexed documents ^{1/} available for a period to be determined in agreement with the administrative service,

10.3.4. analyse the results of each type of test to verify and ensure consistency of the product characteristics, allowing for the variations in industrial production,

10.3.5. ensure that for each type of product at least the tests prescribed in annex 17 to this Regulation are carried out,

10.3.6. ensure that when any samples or test pieces show non-conformity with the type of test concerned, further samples are taken and tested. All necessary steps shall be taken to re-establish conformity in the production concerned.

10.4. The competent authority may at any time verify the methods for checking conformity applicable to each production unit (see paragraph 1.3. of annex 17 to this Regulation).

^{1/} Fragmentation test results shall be recorded even if no photographic print is required.

- 10.4.1. At every inspection, the test data and production records shall be presented to the inspector.
- 10.4.2. The inspector may take samples at random to be tested in the manufacturer's laboratory. The minimum number of samples may be determined in the light of the results of the manufacturer's own checks.
- 10.4.3. When the quality standard appears unsatisfactory or when it seems necessary to verify the validity of the tests carried out under paragraph 10.4.2., the inspector may select samples to be sent to the technical service which conducted the type approval tests.
- 10.4.4. The competent authority may carry out any test prescribed in this Regulation.
- 10.4.5. The normal frequency of inspection shall be 2 per year. If unsatisfactory results are found during any of these inspections, the competent authority shall ensure that all necessary steps are taken to re-establish the conformity of production as quickly as possible.

11. PENALTIES FOR NON-CONFORMITY OF PRODUCTION

- 11.1. The approval granted in respect of a type of safety-glass pane pursuant to this Regulation may be withdrawn if the requirement laid down in paragraph 10.1. above is not complied with.
- 11.2. If a Party to the Agreement which applies this Regulation withdraws an approval it had previously granted, it shall forthwith so notify the other Contracting Parties applying this Regulation thereof by means of a copy of a communication form conforming to the model in annex 1 to this Regulation.

12. TRANSITIONAL PROVISIONS.

- 12.1. As from the date of entry into force of Supplement 3 to this Regulation in its original form, no Contracting Party applying this Regulation shall refuse an application for approval under this Regulation as amended by Supplement 3 to the Regulation in its original form.
- 12.2. As from 24 months after the official date of the entry into force of Supplement 3, the Contracting Parties applying this Regulation may refuse to recognize the approval of safety glazing not bearing the symbols prescribed in paragraph 5.5. of this Regulation.

13. PRODUCTION DEFINITELY DISCONTINUED

If the holder of the approval completely ceases to manufacture a type of safety-glass pane approved in accordance with this Regulation, he shall so inform the authority which granted the approval. Upon receiving the relevant communication, that authority shall inform thereof the other Parties to the Agreement which apply this Regulation by means of a copy of a communication form conforming to the model in annex 1 to this Regulation.

14. NAMES AND ADDRESSES OF TECHNICAL SERVICES RESPONSIBLE FOR CONDUCTING APPROVAL TESTS, AND OF ADMINISTRATIVE DEPARTMENTS

The Parties to the Agreement which apply this Regulation shall communicate to the United Nations Secretariat the names and addresses of the technical services responsible for conducting approval tests and of the administrative departments which grant approval and to which forms certifying approval or extension or refusal or withdrawal of approval, issued in other countries, are to be sent.

Annex 1

(Maximum format: A4 (210 x 297 mm))

2/



Communication concerning: Approval,
 Refusal of approval
 Extension of approval,
 Approval withdrawn
 Production definitely
 discontinued 1/
 of a type of safety-glass pane pursuant to
 Regulation No. 43

Approval No. Extension No:

1. Class of safety-glass pane :.....
2. Description of the glass pane : please refer to appendix 1, 2, 3, 4, 5, 6, 7 1/
and in the case of windscreens, the list conforming to appendix 8.
3. Trade name or mark :.....
4. Manufacturer's name and address :.....
5. If applicable, name and address of manufacturer's representative :.....
6. Submitted for approval on :.....
7. Technical service responsible for conducting approval tests :.....
8. Date of report issued by that service :.....
9. No. of report issued by that service :.....
10. Approval is granted/refused/extended/withdrawn 1/
11. Reason(s) for extension of approval :.....
12. Remarks :.....
13. Place :.....
14. Date :.....
15. Signature :.....
16. The list of documents filed with the administrative service which has granted approval and available on request is annexed to this communication.

1/ Strike out what does not apply.
2/ Name of Administration.

Annex 1 - Appendix 1

TOUGHENED-GLASS WINDSCREENS

(Principal and secondary characteristics as defined in
annex 4 or annex 9 to Regulation No.43)

Approval No.:.....

Extension No.:.....

Principal characteristics :

Shape category:
Thickness category:
Nominal thickness of the windscreen:
Nature and type of plastics coating(s).....:
Thickness of plastics coating(s):

Secondary characteristics :

Nature of the material (plate, float,
sheet glass).....:
Colouring of glass:
Colouring of plastics coating(s):
Conductors incorporated (YES/NO).....:
Anti-glare strips incorporated (YES/NO).....:

Remarks

Documents attached : list of windcreens (see appendix 8).

Annex 1 - Appendix 2

UNIFORMLY-TOUGHENED GLASS PANES

(Principal and secondary characteristics as defined in
annex 5 or annex 9 to Regulation No.43)

Approval No.:.....

Extension No.:.....

Principal characteristics :

- Other than windscreens (YES/NO):
- Windscreen(s) for slow moving vehicles....:
- Shape category:
- Nature of toughening process:
- Thickness category:
- Nature and type of plastics coating(s)....:

Secondary characteristics :

- Nature of the material (plate, float,
sheet glass).....:
- Colouring of glass:
- Colouring of plastics coating(s):
- Conductors incorporated (YES/NO).....:
- Anti-glare strips incorporated (YES/NO)....:

Approved criteria :

- Greatest area (flat glass).....:
- Smallest angle:
- Greatest developed area (curved glass)....:
- Greatest height of segment:

Remarks

Documents attached : list of windscreens (if applicable) (see appendix 8).

Annex 1 - Appendix 3

LAMINATED-GLASS WINDSCREENS

(Principal and secondary characteristics as defined in annexes 6, 8 or 9 to Regulation No.43)

Approval No.:.....

Extension No.:.....

Principal characteristics :

- Number of layers of glass:
- Number of layers of interlayer:
- Nominal thickness of the windscreen:
- Nominal thickness of interlayer(s):
- Special treatment of glass:
- Nature and type of interlayer(s):
- Nature and type of plastics coating(s)....:

Secondary characteristics :

- Nature of the material (plate, float, sheet glass).....:
- Colouring of glass (colourless/tinted) ...:
- Colouring of plastics coating(s):
- Conductors incorporated (YES/NO).....:
- Anti-glare strips incorporated (YES/NO)....:

Remarks

Documents attached : list of windscreens (see appendix 8).

Annex 1 - Appendix 4

LAMINATED-GLASS PANES OTHER THAN WINDSCREENS

(Principal and secondary characteristics as defined in
annex 7 or annex 9 to Regulation No.43)

Approval No. :

Extension No. :

Principal characteristics :

- Number of layers of glass:
- Number of layers of interlayer:
- Thickness category:
- Nominal thickness of interlayer(s):
- Special treatment of glass:
- Nature and type of interlayer(s):
- Nature and type of plastics coating(s).....:
- Thickness of plastics coating(s).....:

Secondary characteristics :

- Nature of the material (plate, float,
sheet glass).....:
- Colouring of interlayer (total/partial) ...:
- Colouring of glass:
- Colouring of plastics coating(s):
- Conductors incorporated (YES/NO).....:
- Anti-glare strips incorporated (YES/NO)....:

Remarks

Annex 1 - Appendix 5

GLASS-PLASTICS WINDSCREENS

(Principal and secondary characteristics as defined in
annex 10 to Regulation No.43)

Approval No. :.....

Extension No.:.....

Principal characteristics

Shape category:

Number of layers of plastics.....:

Nominal thickness of glass:

Treatment of the glass (YES/NO):

Nominal thickness of the windscreen:

Nominal thickness of the layer(s) of
plastics acting as interlayer:

Nature and type of layer(s) of plastics
acting as interlayer:

Nature and type of the outer layer of
plastics:

Secondary characteristics :

Nature of the material (plate, float,
sheet glass).....:

Colouring of glass:

Colouring of the layer(s) of plastics
(total/partial):

Conductors incorporated (YES/NO).....:

Anti-glare strips incorporated (YES/NO)....:

Remarks

Documents attached : list of windscreens (see appendix 8).

Annex 1 - Appendix 6

GLASS-PLASTICS PANES OTHER THAN WINDSCREENS

(Principal and secondary characteristics as defined in
annex 11 to Regulation No.43)

Approval No. :.....

Extension No. :.....

Principal characteristics :

- Number of layers of plastics.....:
- Thickness of the glass component:
- Treatment of the glass component (YES/NO) :
- Nominal thickness of the pane:
- Nominal thickness of the layer(s) of
plastics acting as interlayer:
- Nature and type of layer(s) of plastics
acting as interlayer:
- Nature and type of the outer layer of
plastics:

Secondary characteristics :

- Nature of the material (plate, float,
sheet glass).....:
- Colouring of glass (colourless/tinted) ...:
- Colouring of the layer(s) of plastics
(total/partial):
- Conductors incorporated (YES/NO).....:
- Anti-glare strips incorporated (YES/NO)...

Remarks

Annex 1 - Appendix 7

DOUBLE-GLAZED UNITS

(Principal and secondary characteristics as defined in
annex 12 to Regulation No.43)

Approval No.:.....

Extension No.:.....

Principal characteristics :

- Composition of double-glazed units
(symmetrical/asymmetrical).....:
- Nominal thickness of the gap:
- Method of assembly:
- Type of each glass as defined in annexes
5, 7, 9 or 11:

Documents attached :

One form for the two panes of a symmetrical double-glazed unit in accordance with the annex under which the panes have been tested or approved.

One form for each glass pane of an asymmetrical double-glazed unit in accordance with the annexes under which these panes have been tested or approved.

Remarks

Annex 1 - Appendix 8

CONTENTS OF THE LIST OF WINDSCREENS 1/

For each of the windcreens covered by this approval, at least the following particulars shall be provided :

- Vehicle manufacturer
- Type of vehicle
- Vehicle category
- Developed area (F)
- Height of segment (h)
- Curvature (r)
- Installation angle (α)
- Seat-back angle (β)
- R-point coordinates (A,B,C) relative to the centre of the upper edge of the windscreen.

Description of the parameter F of the windscreen

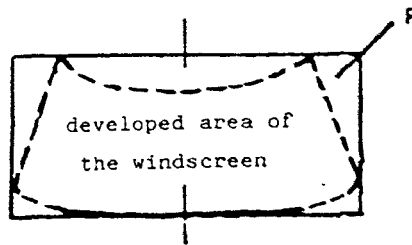

R-point co-ordinates relative to the windscreen

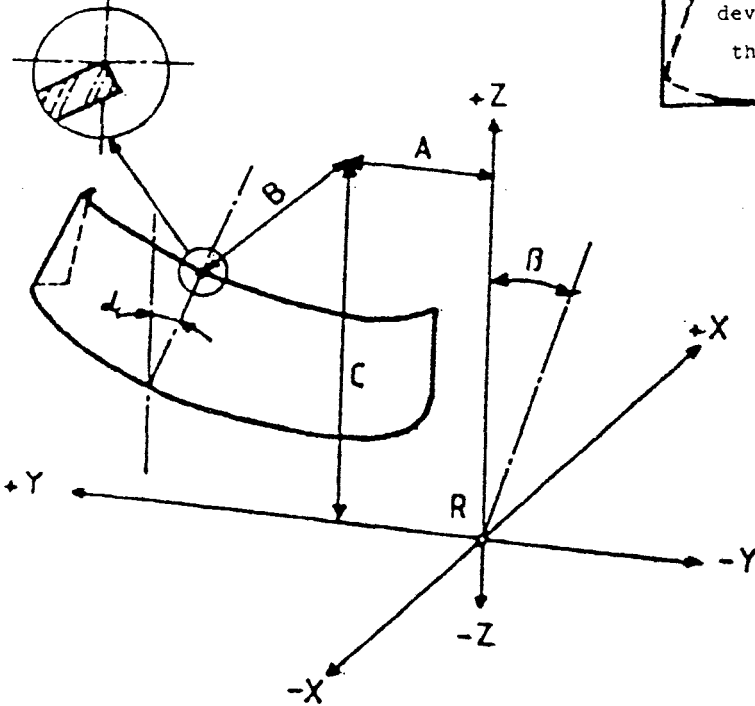

Description of the parameters r and h of the windscreen

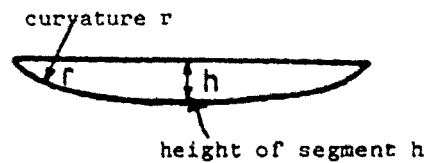

1/ These particulars shall be attached to appendices 1, 2 (if applicable), 3 and 5 to this annex.

Annex 2

ARRANGEMENTS OF APPROVAL MARKS

(see paragraph 5.5. of this Regulation)

Toughened-glass windcreens

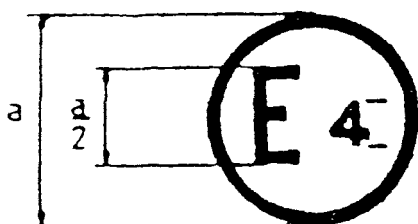

$\frac{a}{3}$ 43 R - 002439

a = 8 mm mini.

The above approval mark affixed to a toughened-glass windscreen shows that the component concerned has been approved in the Netherlands (E 4) pursuant to Regulation No. 43 under approval number 002439. The approval number indicates that the approval was granted in accordance with the requirements of Regulation No. 43 in its original form or as amended by Supplements 1, 2 and/or 3, as the case may be.

Toughened-glass windcreens faced with plastics material



$\frac{a}{3}$ 43 R - 002439

a = 8 mm mini

The above approval mark affixed to a toughened-glass windscreen faced with plastics material shows that the component concerned has been approved in the Netherlands (E 4) pursuant to Regulation No. 43 under approval No. 002439. The approval number indicates that the approval was granted in accordance with the requirements of Regulation No. 43 in its original form as amended by Supplements 2 and/or 3, as the case may be.

Ordinary Laminated-glass windscreens

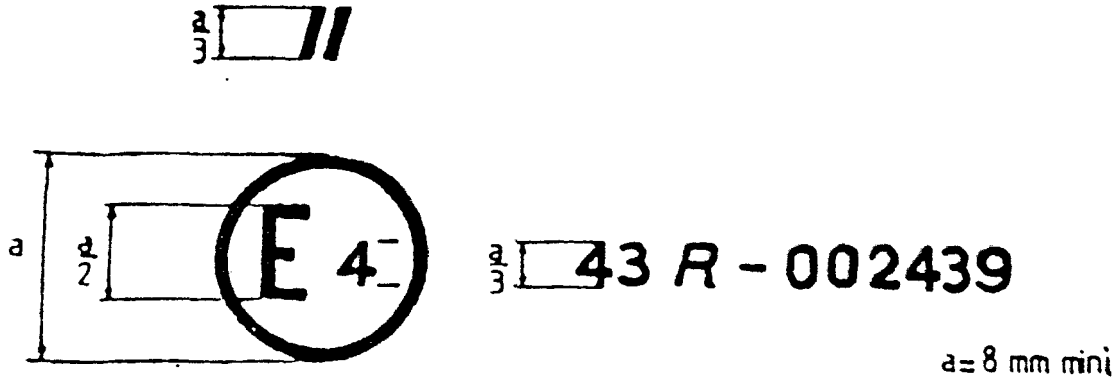

The above approval mark affixed to an ordinary laminated-glass windscreen shows that the component concerned has been approved in the Netherlands (E 4) pursuant to Regulation No. 43 under approval No. 002439. The approval number indicates that the approval was granted in accordance with the requirements of Regulation No. 43 in its original form or as amended by Supplements 1, 2 and/or 3, as the case may be.

Ordinary laminated-glass windscreens faced with plastics material

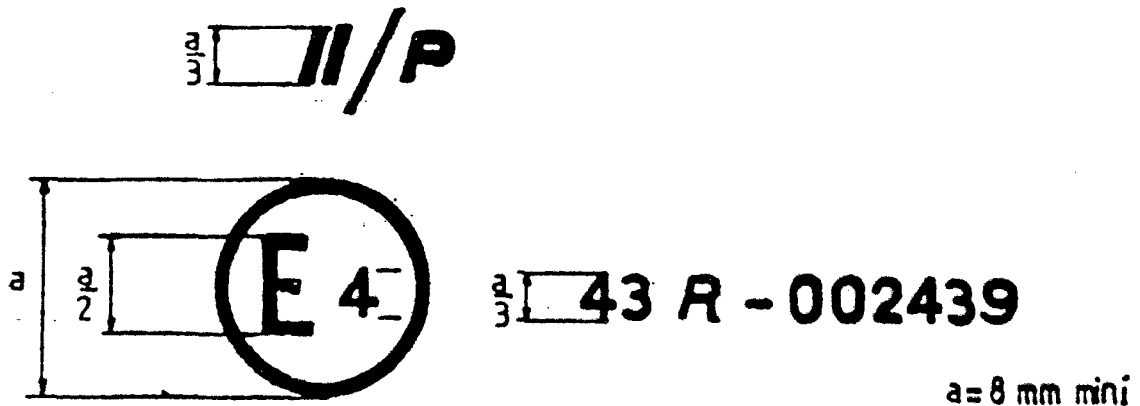

The above approval mark affixed to an ordinary laminated-glass windscreen faced with plastics material shows that the component concerned has been approved in the Netherlands (E 4) pursuant to Regulation No. 43 under approval No. 002439. The approval number indicates that the approval was granted in accordance with the requirements of Regulation No. 43 in its original form as amended by Supplements 2 and/or 3, as the case may be.

Treated laminated-glass windscreens

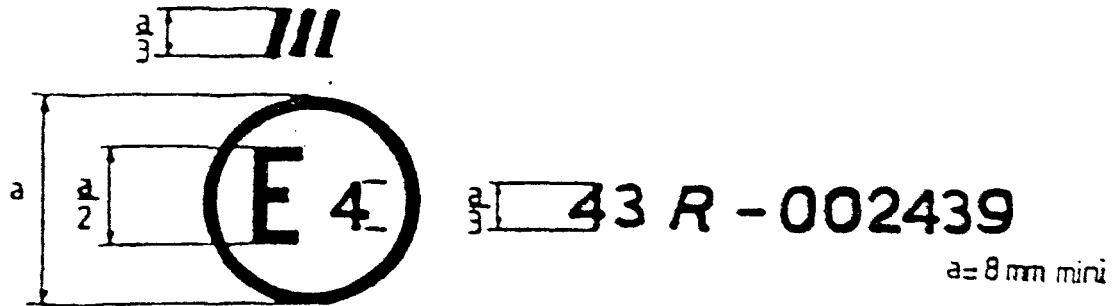

The above approval mark affixed to a treated laminated-glass windscreen shows that the component concerned has been approved in the Netherlands (E 4) pursuant to Regulation No.43 under approval No.002439. The approval number indicates that the approval was granted in accordance with the requirements of Regulation No.43 in its original form or as amended by Supplements 1, 2 and/or 3, as the case may be.

Glass-plastics windscreens

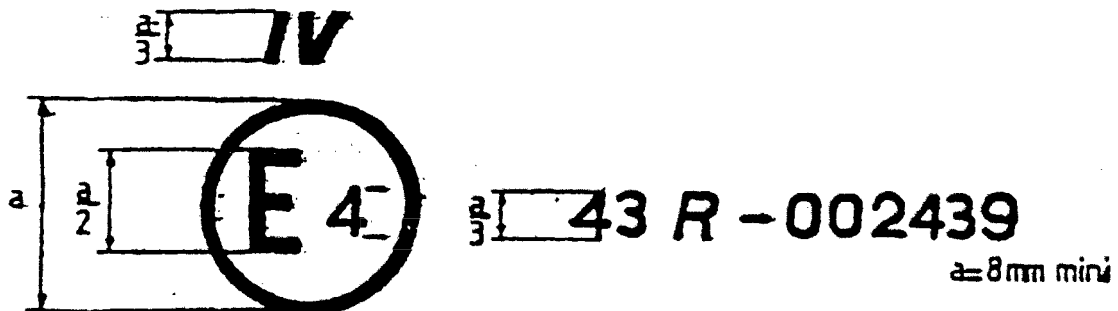

The above approval mark affixed to a glass-plastics windscreen shows that the component concerned has been approved in the Netherlands (E 4) pursuant to Regulation No. 43 under approval No. 002439. The approval number indicates that the approval was granted in accordance with the requirements of Regulation No. 43 in its original form as amended by Supplements 2 and/or 3, as the case may be.

Glass panes other than windscreens having a regular light transmittance < 70 per cent

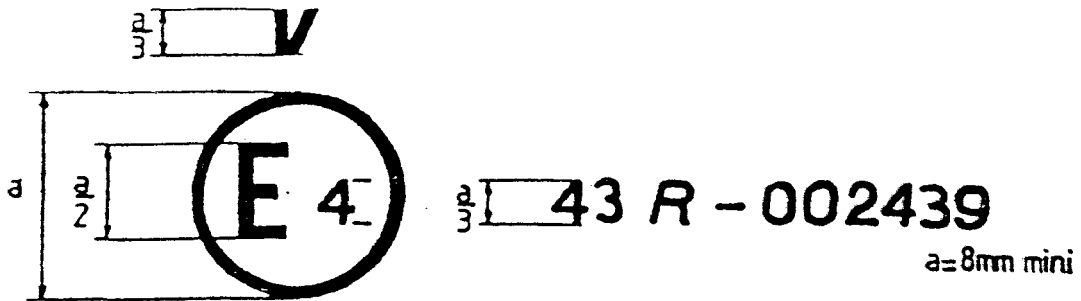

The above approval mark affixed to a glass pane other than a windscreen to which the requirements of annex 3, paragraph 9.1.4.2., are applicable shows that the component concerned has been approved in the Netherlands (E 4) pursuant to Regulation No.43 under approval No.002439. The approval number indicates that the approval was granted in accordance with the requirements of Regulation No.43 in its original form as amended by Supplements 2 and/or 3, as the case may be.

Double-glazed units having a regular light transmittance < 70 per cent

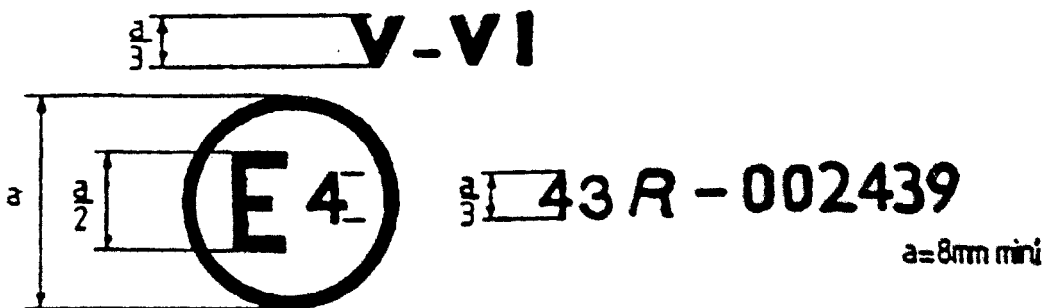

The above approval mark affixed to a double-glazed unit shows that the component concerned has been approved in the Netherlands (E 4) pursuant to Regulation No.43 under approval No. 002439. The approval number indicates that the approval was granted in accordance with the requirements of Regulation No. 43 in its original form as amended by Supplements 1, 2 and 3.

Uniformly-toughened glass panes to be used as windscreen for slow-moving vehicles which by construction cannot exceed 30 km/h

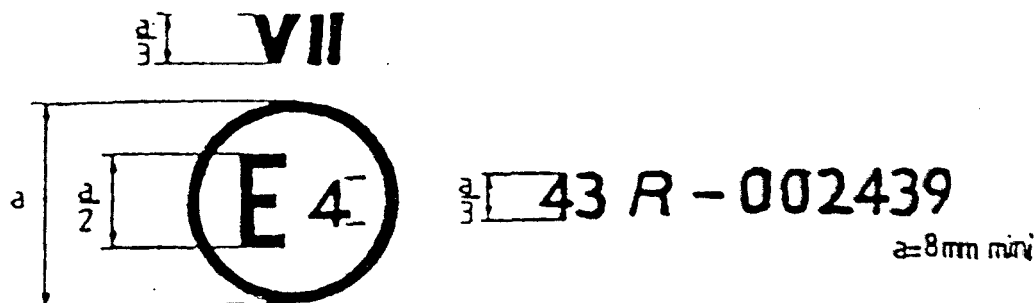

The above approval mark affixed to a uniformly-toughened glass pane shows that the component concerned intended to be used as a windscreen on a slow-moving vehicle which, by construction, cannot exceed 30 km/h, has been approved in the Netherlands (E 4) pursuant to Regulation No.43 under approval No. 002439. The approval number indicates that the approval was granted in accordance with the requirements of Regulation No. 43 in its original form as amended by Supplements 1, 2 and 3.

Glass panes other than windscreens having a regular light transmittance \geq 70 per cent

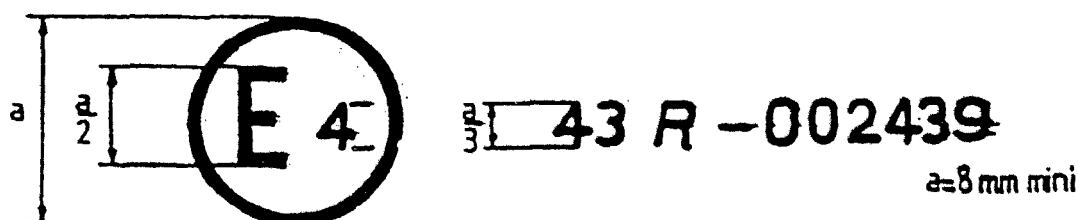

The above approval mark affixed to a glass pane other than a windscreen to which the requirements of annex 3, paragraph 9.1.4.1., are applicable shows that the component concerned has been approved in the Netherlands (E 4) pursuant to Regulation No.43 under approval No. 002439. The approval number indicates that the approval was granted in accordance with the requirements of Regulation No. 43 in its original form or as amended by Supplements 1, 2 and/or 3, as the case may be.

Annex 3

GENERAL TEST CONDITIONS

1. FRAGMENTATION TEST

- 1.1. The glass pane to be tested shall not be rigidly secured; it may however be fastened on an identical glass pane by means of adhesive tape applied all round the edge.
- 1.2. To obtain fragmentation, a hammer of about 75 g or some other appliance giving equivalent results shall be used. The radius of curvature of the point shall be 0.2 ± 0.05 mm.
- 1.3. One test shall be carried out at each prescribed point of impact.
- 1.4. An examination shall be made of the fragments on photographic contact paper, exposure commencing not more than 10 seconds and terminating not more than three minutes after impact. Only the darkest lines, representing the initial fracture, shall be taken into consideration. The laboratory shall keep photographic reproductions of the fragmentation obtained.

2. BALL-IMPACT TESTS

2.1. 227 g ball test

2.1.1. Apparatus

- 2.1.1.1. Hardened-steel ball with a mass of 227 ± 2 g and a diameter of approximately 38 mm.
- 2.1.1.2. Means for dropping the ball freely from a height to be specified, or a means for giving the ball a velocity equivalent to that obtained by the free fall. When a device to project the ball is used, the tolerance on velocity shall be ± 1 per cent of the velocity equivalent to that obtained by the free fall.
- 2.1.1.3. Supporting fixture, such as that shown in figure 1, composed of steel frames, with machined borders 15 mm wide, fitting one over the other and faced with rubber gaskets about 3 mm thick and 15 mm wide and of hardness 50 IRHD.

The lower frame rests on a steel box about 150 mm high. The test piece is held in place by the upper frame, the mass of which is about 3 kg. The supporting frame is welded onto a sheet of steel of about 12 mm thick resting on the floor with an interposed sheet of rubber about 3 mm thick and of hardness 50 IRHD.

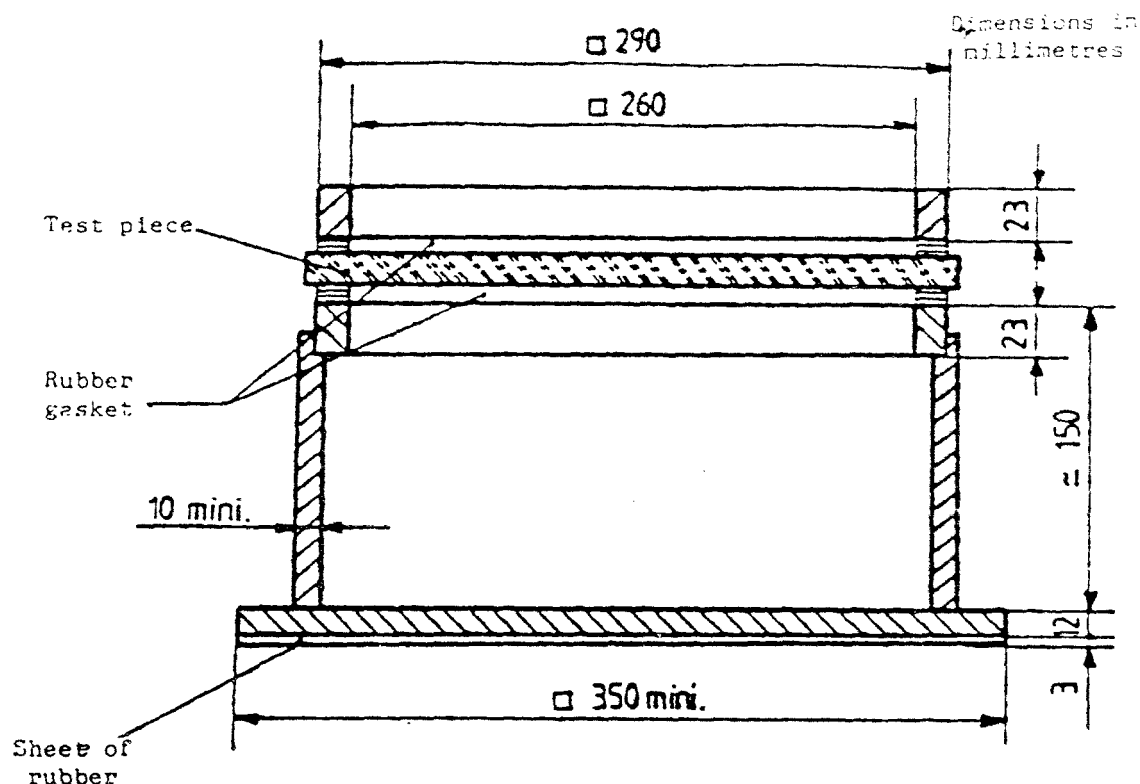

Figure 1 : Support for ball tests

2.1.2. Test conditions

Temperature : $20 \pm 5^\circ\text{C}$
 Pressure : 860 to 1,060 mbar
 Relative humidity : 60 ± 20 per cent.

2.1.3. Test piece

The test piece shall be a flat square of side $300 \pm \frac{10}{0}$ mm.

2.1.4. Procedure

Condition the test piece at the specified temperature for at least four hours immediately preceding the test.

Place the test piece in the fixture (paragraph 2.1.1.3.). The plane of the test piece shall be perpendicular, within 3° , to the incident direction of the ball.

The point of impact shall be within 25 mm of the geometric centre of the test piece for a drop height less than or equal to 6 mm, and within 50 mm of the centre of the test piece for a drop height greater than 6 mm.

The ball shall strike that face of the test piece which represents the outside face of the safety-glass pane when mounted on the vehicle.

The ball shall be allowed to make only one impact.

2.2. 2,260 g ball test

2.2.1. Apparatus

2.2.1.1. Hardened-steel ball with a mass of 2,260 \pm 20 g and a diameter of approximately 82 mm.

2.2.1.2. Means for dropping the ball freely from a height to be specified, or means for giving the ball a velocity equivalent to that obtained by the free fall. When a device to project the ball is used, the tolerance on velocity shall be \pm 1 per cent of the velocity equivalent to that obtained by the free fall.

2.2.1.3. The supporting fixture shall be as shown in figure 1 and identical with that described in paragraph 2.1.1.3..

2.2.2. Test conditions

Temperature : 20 \pm 5°
Pressure : 860 to 1,060 mbar
Relative humidity : 60 \pm 20 per cent.

2.2.3. Test piece

The test piece shall be a flat square of side 300 \pm $\begin{matrix} 10 \\ 0 \end{matrix}$ mm, or shall be cut out from the flattest part of a windscreen or other curved pane of safety glass.

Alternatively, the whole windscreen or other curved pane of safety glass may be tested. In this case care shall be taken to ensure adequate contact between the safety-glass pane and the support.

2.2.4. Procedure

Condition the test piece at the specified temperature for at least four hours immediately preceding the test.

Place the test piece in the fixture (paragraph 2.1.1.3.). The plane of the test piece shall be perpendicular, within 3°, to the incident direction of the ball.

In the case of glass-plastics glazing the test piece shall be clamped to the support.

The point of impact shall be within 25 mm of the geometric centre of the test piece.

The ball shall strike that face of the test piece which represents the inward face of the safety-glass pane when the latter is mounted on the vehicle.

The ball shall be allowed to make only one impact.

3. HEADFORM TEST

3.1. Apparatus

3.1.1. Headform weight with a spherical or semi-spherical headform made of laminated hardwood covered with replaceable felt and with or without a cross-beam made of wood. There is a neck-shaped intermediate piece between the spherical part and the cross-beam and a mounting rod on the other side of the cross-beam.

The dimensions shall be in accordance with figure 2.

The total mass of the apparatus shall be 10 \pm 0.2 kg.

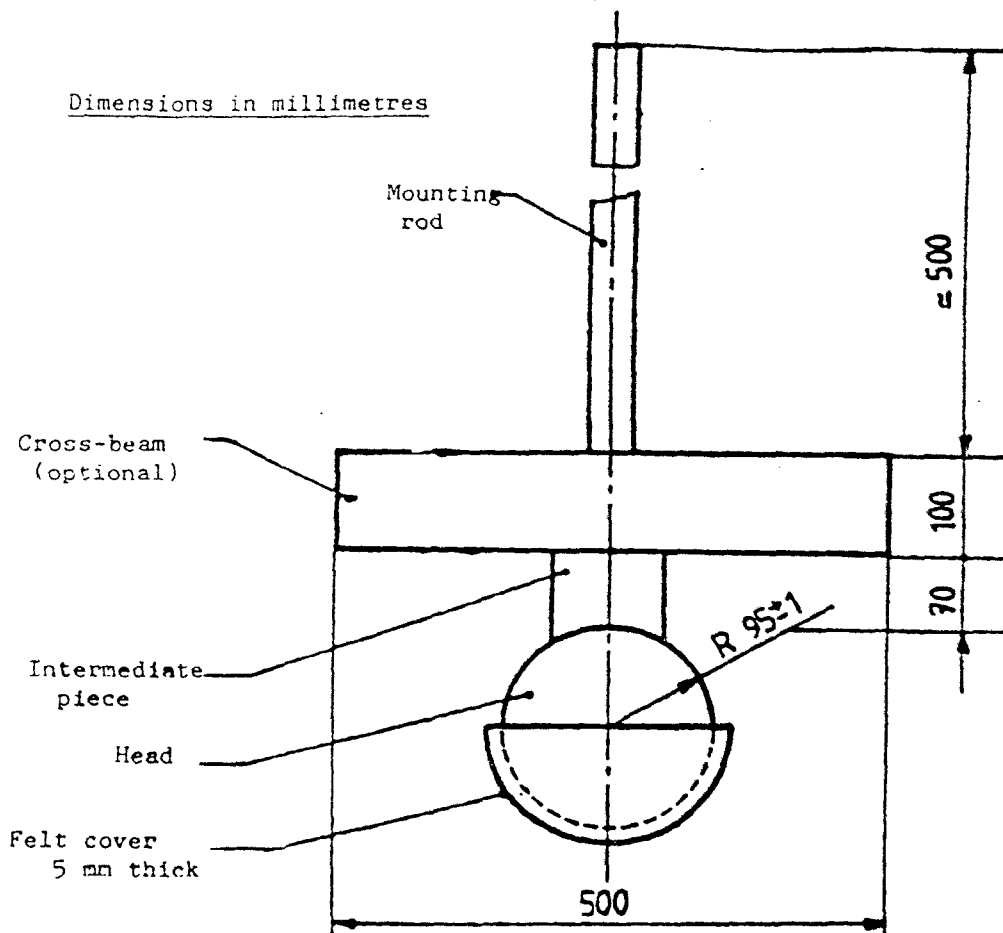

Figure 2 : Headform weight

3.1.2. Means for dropping the headform weight freely from a height to be specified, or means for giving the weight a velocity equivalent to that obtained by the free fall.

When a device to project the headform weight is used, the tolerance on velocity shall be ± 1 per cent of the velocity equivalent to that obtained by the free fall.

3.1.3. Supporting fixture, as shown in figure 3, for testing flat test pieces. The fixture is composed of two steel frames, with machined borders 50 mm wide, fitting one over the other and faced with rubber gaskets about 3 mm thick and 15 ± 1 mm wide and of hardness 70 IRHD.

The upper frame is held pressed against the lower frame by at least eight bolts.

3.2. Test conditions

Temperature : $20 \pm 5^\circ \text{C}$

Pressure : 860 to 1,060 mbar

Relative humidity : 60 ± 20 per cent.

3.3. Procedure

3.3.1. Test on a flat test piece

The flat test piece, having a length of $1,100 \pm 5$ mm and a width of 500 ± 5 mm, shall be kept at a constant temperature of $20 \pm 5^\circ \text{C}$ for at least four hours immediately preceding the test.

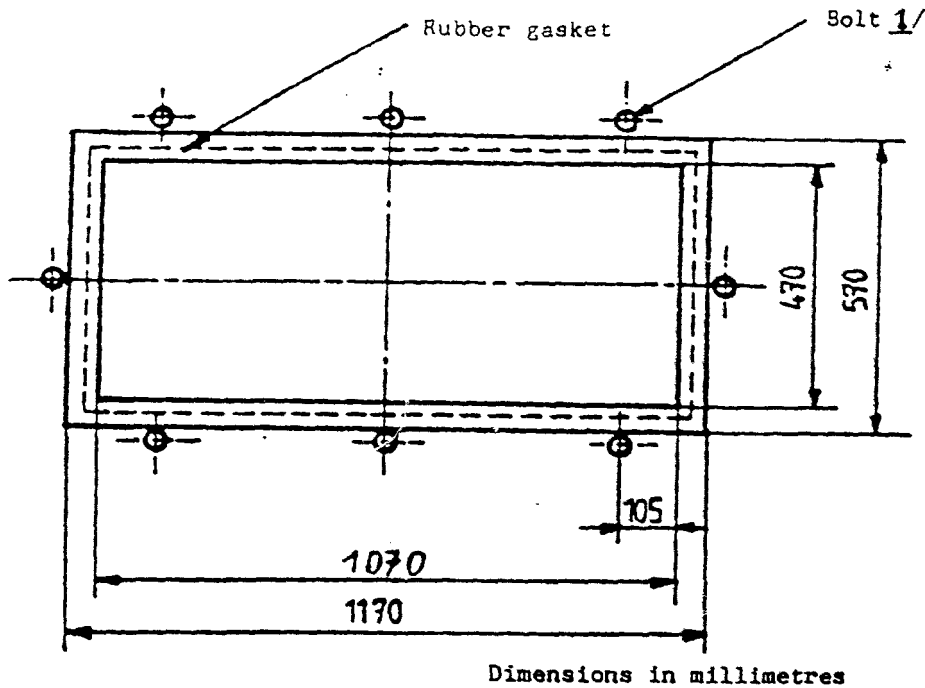

Figure 3 : Support for headform tests

3.3.1. Fix the test piece in the supporting frames (paragraph 3.1.3.);
 (ctn'd) the torque on the bolts shall ensure that the movement of the test piece during the test will not exceed 2 mm. The plane of the test piece shall be substantially perpendicular to the incident direction of the weight. The weight shall strike the test piece within 40 mm of its geometric centre on that face which represents the inward face of the safety-glass pane when the latter is mounted on the vehicle, and shall be allowed to make only one impact.
 The impact surface of the felt cover shall be replaced after 12 tests.

3.3.2. Tests on a complete windscreen (used only for a drop height of less than or equal to 1.5 m)

Place the windscreen freely on a support with an interposed strip of rubber of hardness 70 IRHD and thickness about 3 mm, the width of contact over the whole perimeter being about 15 mm.
 The support shall consist of a rigid piece corresponding to the shape of the windscreen so that the headform weight strikes the internal surface.
 If necessary the windscreen shall be clamped to the support.

^{1/} The minimum recommended torque for M 20 is 30 Nm.

The support shall rest on a rigid stand with an interposed sheet of rubber of hardness 70 IRHD and thickness about 3 mm. The surface of the windscreen shall be substantially perpendicular to the incident direction of the headform weight.

The headform weight shall strike the windscreen at a point within 40 mm of its geometric centre on that face which represents the inward face of the safety-glass pane when the latter is mounted on the vehicle, and shall be allowed to make only one impact.

The impact surface of the felt cover shall be replaced after 12 tests.

4. TEST OF RESISTANCE TO ABRASION

4.1. Apparatus

4.1.1. Abrading instrument ^{1/}, shown diagrammatically in figure 4 and consisting of :

A horizontal turntable, with centre clamp, which revolves counter-clockwise at 65 to 75 rev/min.;

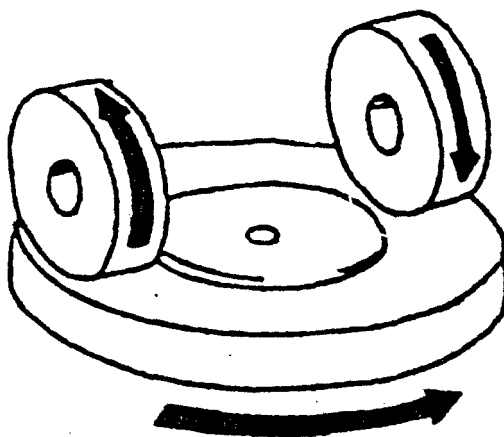

Figure 4 : Diagram of abrading instrument

Two weighted parallel arms each carrying a special abrasive wheel freely rotating on a ball-bearing horizontal spindle; each wheel rests on the test specimen under the pressure exerted by a mass of 500 g.

The turntable of the abrading instrument shall rotate regularly, substantially in one plane (the deviation from this plane shall not be greater than ± 0.05 mm at a distance of 1.6 mm from the turntable periphery).

The wheels shall be mounted in such a way that when they are in contact with the rotating test piece they rotate in opposite directions so as to exert, twice during each rotation of the test piece, a compressive and abrasive action along curved lines over an annular area of about 30 cm².

^{1/} A suitable abrading instrument is supplied by Teledyne Taber (United States of America).

- 4.1.2. Abrasive wheels ^{1/}, each 45 to 50 mm in diameter and 12.5 mm thick, composed of a special finely-screened abrasive embedded in a medium-hard rubber. The wheels shall have a hardness of 72 ± 5 IRHD, as measured at four points equally spaced on the centreline of the abrading surface, the pressure being applied vertically along a diameter of the wheel and the readings being taken 10 seconds after full application of the pressure.

The abrasive wheels shall be prepared for use by very slow rotation against a sheet of flat glass to ensure that their surface is completely even.

- 4.1.3. Light source consisting of an incandescent lamp with its filament contained within a parallelepiped measuring 1.5 mm x 1.5 mm x 3 mm. The voltage at the lamp filament shall be such that the colour temperature is 2856 ± 50 K. This voltage shall be stabilized within $\pm 1/1000$. The instrument used to check the voltage shall be of appropriate accuracy.
- 4.1.4. Optical system consisting of a lens with a focal length f of at least 500 mm and corrected for chromatic aberrations. The full aperture of the lens shall not exceed $f/20$. The distance between the lens and the light source shall be adjusted in order to obtain a light beam which is substantially parallel. A diaphragm shall be inserted to limit the diameter of the light beam to 7 ± 1 mm. This diaphragm shall be situated at a distance of 100 ± 50 mm from the lens on the side remote from the light source.
- 4.1.5. Equipment for measuring scattered light (see figure 5), consisting of a photoelectric cell with an integrating sphere 200 to 250 mm in diameter. The sphere shall be equipped with entrance and exit ports for the light. The entrance port shall be circular and have a diameter at least twice that of the light beam. The exit port of the sphere shall be provided with either a light trap or a reflectance standard, according to the procedure described in paragraph 4.4.3. below. The light trap shall absorb all the light when no test piece is inserted in the light beam.

The axis of the light beam shall pass through the centre of the entrance and exit ports. The diameter b of the light-exit port shall be equal to $2 a \cdot \tan 4^\circ$, where a is the diameter of the sphere. The photoelectric cell shall be mounted in such a way that it cannot be reached by light coming directly from the entrance port or from the reflectance standard.

The surfaces of the interior of the integrating sphere and the reflectance standard shall be of substantially equal reflectance and shall be matt and non-selective.

The output of the photoelectric cell shall be linear within ± 2 per cent over the range of luminous intensities used. The design of the instrument shall be such that there is no galvanometer deflection when the sphere is dark.

The whole apparatus shall be checked at regular intervals by means of calibration standards of defined haze.

If haze measurements are made using equipment or methods differing from those defined above, the results shall be corrected, if necessary, to bring them into agreement with those obtained by the apparatus described above.

^{1/} Suitable abrasive wheels may be obtained from Teledyne Taber (United States of America).

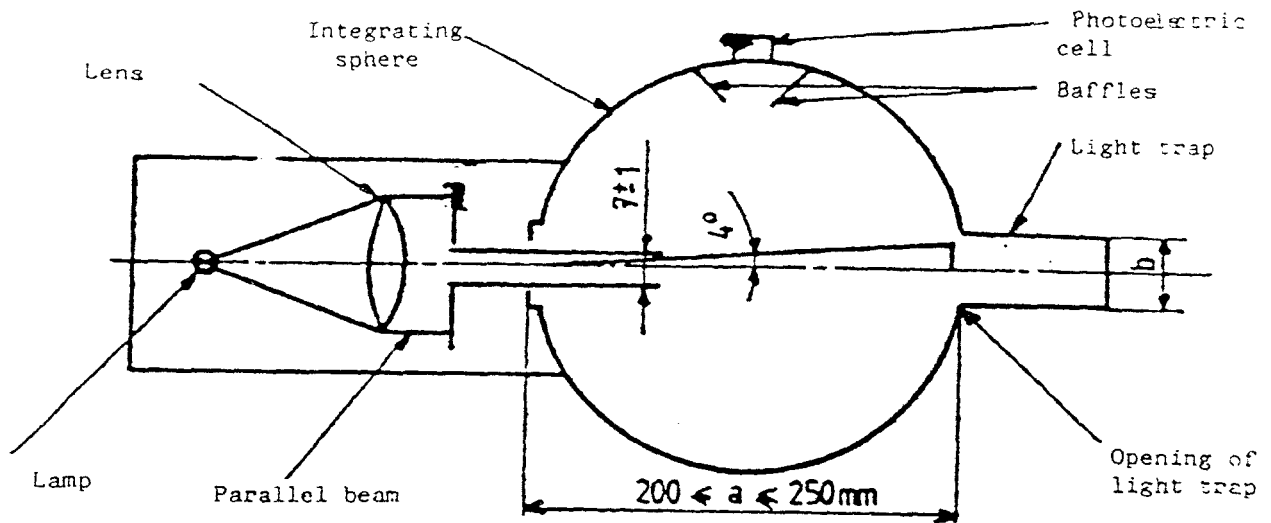

Figure 5 : Hazemeter

4.2. Test conditions

Temperature : $20 \pm 5^\circ\text{C}$
 Pressure : 860 to 1,060 mbar
 Relative humidity : 60 ± 20 per cent.

4.3. Test pieces

The test pieces shall be flat squares of side 100 mm having both surfaces substantially plane and parallel and having a fixing hole $6.4 \pm_{-0}^{+0.2}$ mm in diameter drilled in the centre, if necessary.

4.4. Procedure

The abrasion test shall be carried out on that surface of the test piece which represents the outside face of the laminated-glass pane when the latter is mounted on the vehicle and also on the inner face if of plastics material.

4.4.1. Immediately before and after the abrasion, clean the test pieces in the following manner :

- (a) wipe with a linen cloth under clear running water,
- (b) rinse with distilled or demineralized water,
- (c) blow dry with oxygen or nitrogen,
- (d) remove possible traces of water by dabbing softly with a damp linen cloth. If necessary, dry by pressing lightly between two linen cloths.

Any treatment with ultrasonic equipment shall be avoided.

After cleaning, the test pieces shall be handled only by their edges and shall be stored to prevent damage to, or contamination of, their surfaces.

4.4.2. Condition the test pieces for a minimum time of 48 hours at $20 \pm 5^\circ\text{C}$ and 60 ± 20 per cent relative humidity.

4.4.3. Immediately place the test piece against the entrance port of the integrating sphere. The angle between the normal (perpendicular) to the surface of the test piece and the axis of the light beam shall not exceed 8°.

Take four readings as indicated in the following table :

Reading	With test piece	With light-trap	With reflectance standard	Quantity represented
T ₁	No	No	Yes	Incident light
T ₂	Yes	No	Yes	Total light transmitted by test-piece
T ₃	No	Yes	No	Light scattered by instrument
T ₄	Yes	Yes	No	Light scattered by instrument and test piece

Repeat readings for T₁, T₂, T₃ and T₄ with other specified positions of the test piece to determine uniformity.

Calculate the total transmittance $T_t = T_2/T_1$.

Calculate the diffuse transmittance T_d as follows :

$$T_d = \frac{T_4 - T_3 (T_2 / T_1)}{T_1}$$

Calculate the percentage haze, or light, or both, scattered, as follows :

$$\text{Haze, or light, or both, scattered,} = \frac{T_d}{T_t} \times 100 \%$$

Measure the initial haze of the test piece at a minimum of four equally-spaced points in the unabraded area in accordance with the formula above. Average the results for each test piece. In lieu of the four measurements, an average value may be obtained by rotating the piece uniformly at 3 rev/sec or more.

For each safety-glass pane, carry out three tests with the same load. Use the haze as a measure of the subsurface abrasion, after the test piece has been subjected to the abrasion test.

Measure the light scattered by the abraded track at a minimum of four equally-spaced points along the track in accordance with the formula above. Average the results for each test piece. In lieu of the four measurements, an average value may be obtained by rotating the piece uniformly at 3 rev/sec or more.

- 4.5. The abrasion test will be carried out only at the discretion of the laboratory conducting the test with due regard to the information already at its disposal.

Except for glass-plastics materials, changes in the interlayer or material thickness will not normally necessitate further testing.

- 4.6. Indices of difficulty of the secondary characteristics
No secondary characteristics are involved.

5. TEST OF RESISTANCE TO HIGH TEMPERATURE

5.1. Procedure

Heat to 100°C three samples or three square test pieces of at least 300 x 300 mm which have been cut by the laboratory from three windscreens or three glass panes other than windscreens as the case may be, one edge of which corresponds to the upper edge of the glazing.

Maintain this temperature for a period of two hours, then allow the samples or test pieces to cool to room temperature.

If the safety-glass pane has both external surfaces of inorganic material, the test may be carried out by immersing the sample vertically in boiling water for the specified period of time, care being taken to avoid undue thermal shock.

If samples are cut from windscreens, one edge of each such sample shall be part of an edge of the windscreen.

5.2. Indices of difficulty of the secondary characteristics

	<u>Colourless</u>	<u>Tinted</u>
Colouring of the interlayer	1	2

The other secondary characteristics are not involved.

5.3. Interpretation of results

- 5.3.1. The test for resistance to high temperature shall be considered to give a positive result if bubbles or other defects are not formed more than 15 mm from an uncut edge or 25 mm from a cut edge of the test piece or sample or more than 10 mm away of any cracks which may occur during the test.

- 5.3.2. A set of test pieces or samples submitted for approval shall be considered satisfactory from the point of view of the test for resistance to high temperature if either of the following conditions is fulfilled :

5.3.2.1. All the tests give a satisfactory result; or

5.3.2.2. One test having given an unsatisfactory result, a further series of tests carried out on a new set of test pieces or samples gives satisfactory results.

6. RESISTANCE-TO-RADIATION TEST

6.1. Test method

6.1.1. Apparatus

- 6.1.1.1. Radiation source consisting of a medium-pressure mercury-vapour arc lamp with a tubular quartz bulb of ozone-free type; the bulb axis shall be vertical. The nominal dimensions of the lamp shall be 360 mm in length by 9.5 mm in diameter. The arc length shall be 300 ± 4 mm. The lamp shall be operated at 750 ± 50 W.

Any other source of radiation which produces the same effect as the lamp specified above may be used. To check that the effects of another source are the same, a comparison shall be made by measuring the amount of energy emitted within a wavelength range of 300 to 450 nanometers, all other wavelengths being removed by the use of suitable filters. The alternative source shall then be used with these filters.

In the case of safety-glass panes for which there is no satisfactory correlation between this test and the conditions of use it will be necessary to review the test conditions.

- 6.1.1.2. Power-supply transformer and capacitor capable of supplying to the lamp (paragraph 6.1.1.1.) a starting peak voltage of 1,100 V minimum and an operating voltage of 500 ± 50 V.
- 6.1.1.3. Device for mounting and rotating the test pieces at 1 to 5 rev/min about the centrally-located radiation source in order to ensure even exposure.

6.1.2. Test pieces

- 6.1.2.1. The size of the test pieces shall be 76 x 300 mm.
- 6.1.2.2. The test pieces shall be cut by the laboratory from the upper part of the glass panes in such a way that :

In the case of glass panes other than windscreens, the upper edge of the test piece coincides with the upper edge of the glass pane,

In the case of windscreens, the upper edge of the test piece coincides with the upper limit of the zone in which regular transmittance shall be measured, determined in accordance with paragraph 9.1.2.2. of this annex.

6.1.3. Procedure

Check the regular light transmittance, determined according to paragraphs 9.1.1. to 9.1.2. of this annex, of three test pieces before exposure. Protect a portion of each test piece from the radiation, and then place the test pieces in the test apparatus 230 mm from and parallel lengthwise to the lamp axis. Maintain the temperature of the test pieces at $45 \pm 5^\circ\text{C}$ throughout the test.

That face of each test piece which would constitute a glazed exterior part of the vehicle shall face the lamp. For the type of lamp specified in paragraph 6.1.1.1. the exposure time shall be 100 hours.

After exposure, measure the regular light transmittance again in the exposed area of each test piece.

6.1.4. Each test piece or sample (total number 3 pieces) shall be subjected, in accordance with the procedure above, to radiation such that the radiation on each point of the test piece or sample produces on the interlayer used the same effect as that which would be produced by solar radiation of 1,400 W/m² for 100 hours.

6.2. Indices of difficulty of the secondary characteristics

	<u>Colourless</u>	<u>Tinted</u>
Colouring of glass	2	1
Colouring of interlayer	1	2

The other secondary characteristics are not involved.

6.3. Interpretation of results

6.3.1. The test for resistance to radiation shall be deemed to have given a positive result if the following conditions are fulfilled :

6.3.1.1. The total light transmittance when measured pursuant to paragraphs 9.1.1. and 9.1.2. of this annex does not fall below 95 per cent of the original value before irradiation and in any event does not fall :

6.3.1.1.1. below 70 per cent in the case of glass panes other than windscreens which are required to comply with the specifications regarding the driver's field of view in all directions;

6.3.1.1.2. below 75 per cent in the case of windscreens in the zone where regular transmittance is measured, as defined in paragraph 9.1.2.2. below.

6.3.1.2. The test piece or sample may however show a slight coloration after irradiation when examined against a white background, but no other defect may be apparent.

6.3.2. A set of test pieces or samples submitted for approval shall be considered satisfactory from the point of view of the resistance-to-radiation test if one of the following conditions is fulfilled :

6.3.2.1. All the tests give a satisfactory result;

6.3.2.2. One test having given an unsatisfactory result, a further series of tests carried out on a new set of test pieces or samples gives satisfactory results.

7. RESISTANCE-TO-HUMIDITY TEST

7.1. Procedure

Keep three samples or three square test pieces of at least 300 x 300 mm in a vertical position for two weeks in a closed container in which the temperature is maintained at 50 ± 2°C and the relative humidity at 95 ± 4 per cent.

The test pieces shall be prepared in such a way that :
 - at least one edge of the test pieces coincides with an original edge of the glass pane,
 - if several test pieces are tested at the same time, adequate spacing shall be provided between them.

Precautions shall be taken to prevent condensate from the walls or ceiling of the test chamber from falling on the test pieces.

7.2. Indices of difficulty of the secondary characteristics

	<u>Colourless</u>	<u>Tinted</u>
Colouring of interlayer	1	2

The other secondary characteristics are not involved.

7.3. Interpretation of results

7.3.1. Safety glazing shall be deemed to be satisfactory from the point of view of resistance to humidity if no significant change is observed more than 10 mm from the uncut edges and more than 15 mm from the cut edges after ordinary and treated laminated glass panes have been maintained for two hours in the ambient atmosphere, and plastics-faced and glass-plastics panes have been maintained for 48 hours in the ambient atmosphere.

7.3.2. A set of test pieces or samples submitted for approval shall be considered satisfactory from the point of view of the resistance-to-humidity test if one of the following conditions is fulfilled :

7.3.2.1. All the tests give a satisfactory result;

7.3.2.2. One test having given an unsatisfactory result, a further series of tests carried out on a new set of samples gives satisfactory results.

8. TEST OF RESISTANCE TO TEMPERATURE CHANGES

8.1. Test method

Two test pieces 300 x 300 mm shall be placed in an enclosure at a temperature of $-40^{\circ}\text{C} \pm 5^{\circ}\text{C}$ for a period of 6 hours; they shall then be placed in the open air at a temperature of $23^{\circ}\text{C} \pm 2^{\circ}\text{C}$ for one hour or until temperature equilibrium has been reached by the test pieces. These shall then be placed in circulating air at a temperature of $72^{\circ}\text{C} \pm 2^{\circ}\text{C}$ for 3 hours. After being placed again in the open air at $23^{\circ}\text{C} \pm 2^{\circ}\text{C}$ and cooled to that temperature, the test pieces shall be examined.

8.2. Indices of difficulty of secondary characteristics

	<u>Colourless</u>	<u>Tinted</u>
Colouring of the interlayer or of the plastics coating	1	2

The other secondary characteristics are not involved.

8.3. Interpretation of results

The test for resistance to temperature changes shall be considered to have given a satisfactory result if the test pieces do not show any evidence of cracking, clouding, separation of layers or other apparent deterioration.

9. OPTICAL QUALITIES

9.1. Light transmission test

9.1.1. Apparatus

9.1.1.1. Light source consisting of an incandescent lamp with its filament contained within a parallelepiped measuring 1.5 mm x 1.5 mm x 3 mm. The voltage at the lamp filament shall be such that the colour temperature is 2856 ± 50 K. This voltage shall be stabilized within $\pm 1/1000$. The instrument used to check the voltage shall be of appropriate accuracy.

9.1.1.2. Optical system consisting of a lens with a focal length f of at least 500 mm and corrected for chromatic aberrations. The full aperture of the lens shall not exceed $f/20$. The distance between the lens and the light source shall be adjusted in order to obtain a light beam which is substantially parallel. A diaphragm shall be inserted to limit the diameter of the light beam to 7 ± 1 mm. This diaphragm shall be situated at a distance of 100 ± 50 mm from the lens on the side remote from the light source. The point of measurement shall be taken at the centre of the light beam.

9.1.1.3. Measuring equipment

The receiver shall have a relative spectral sensitivity in substantial agreement with the relative spectral luminous efficiency for the ICI ^{1/} standard photometric observer for photopic vision. The sensitive surface of the receiver shall be covered with a diffusing medium and shall have at least twice the cross-section of the light beam emitted by the optical system. If an integrating sphere is used, the aperture of the sphere shall have a cross-sectional area at least twice that of the parallel portion of the beam.

The linearity of the receiver and the associated indicating instrument shall be better than 2 per cent of the effective part of the scale.

The receiver shall be centred on the axis of the light beam.

9.1.2. Procedure

The sensitivity of the measuring system shall be adjusted in such a way that the instrument indicating the response of the receiver indicates 100 divisions when the safety-glass pane is not inserted in the light path. When no light is falling on the receiver, the instrument shall read zero.

Place the safety-glass pane at a distance from the receiver equal to approximately five times the diameter of the receiver. Insert the safety-glass pane between the diaphragm and the receiver and adjust its orientation in such a way that the angle of incidence of the light beam is equal to $0 \pm 5^\circ$. The regular transmittance shall be measured on the safety-glass pane, and for every point measured the number of divisions, n , shown on the indicating instrument, shall be read. The regular transmittance τ_r is equal to $n/100$.

^{1/} International Commission on Illumination.

- 9.1.2.1. In the case of windscreens, alternative test methods may be applied using either a test piece cut from the flattest part of a windscreen or a specially-prepared flat square with material and thickness characteristics identical to those of the actual windscreen, the measurements being taken normal (perpendicular) to the glass pane.
- 9.1.2.2. For the windscreens of M₁ vehicles ^{1/} the test shall be carried out in zone B defined in annex 15 to this Regulation. For all other vehicles the test shall be carried out in zone I defined in paragraph 9.2.5.2.3. of this annex.

However, for agricultural and forestry tractors and for construction-site vehicles for which it is not possible to determine zone I, the test shall be carried out in zone I' as defined in paragraph 9.2.5.3. of this annex.

9.1.3. Indices of difficulty of the secondary characteristics

	<u>Colourless</u>	<u>Tinted</u>
Colouring of the glass	1	2
Colouring of the interlayer (in the case of laminated windscreens)	1	2
	<u>not included</u>	<u>included</u>
Shade and/or obscuration bands	1	2

The other secondary characteristics are not involved.

9.1.4. Interpretation of results

- 9.1.4.1. The regular transmittance measured according to paragraph 9.1.2. in the case of windscreens shall not be less than 75 per cent and, in the case of windows other than windscreens shall not be less than 70 per cent.
- 9.1.4.2. In the case of glass panes in places not essential for the driver's vision (e.g. sun roofs) the regular light transmittance of the glass pane may be less than 70 per cent. Glass panes with a regular light transmittance less than 70 per cent shall be appropriately marked.

9.2. Optical distortion test

9.2.1. Scope

The method specified is a projection method which permits evaluation of the optical distortion of a safety-glass pane.

9.2.1.1. Definitions

- 9.2.1.1.1. Optical deviation : The angle between the true and the apparent direction of a point viewed through the safety-glass pane, the magnitude of the angle being a function of the angle of incidence of the line of sight, the thickness and inclination of the glass pane, and the radius of curvature at the point of incidence.

^{1/} As defined in Regulation No.13 concerning the approval of vehicles with regard to braking (E/ECE/324-E/ECE/TRANS/505/Rev.1/Add.12/Rev.2).

9.2.1.1.2. Optical distortion in a direction M-M' : The algebraic difference in angular deviation $\Delta \alpha$ measured between two points M and M' on the surface of the glass pane, the distance between the two points being such that their projections in a plane at right angles to the direction of vision are separated by a given distance Δx (see figure 6).

Anti-clockwise deviation should be regarded as positive and clockwise deviation as negative.

9.2.1.1.3. Optical distortion at a point M : The optical-distortion maximum for all directions M-M' from the point M.

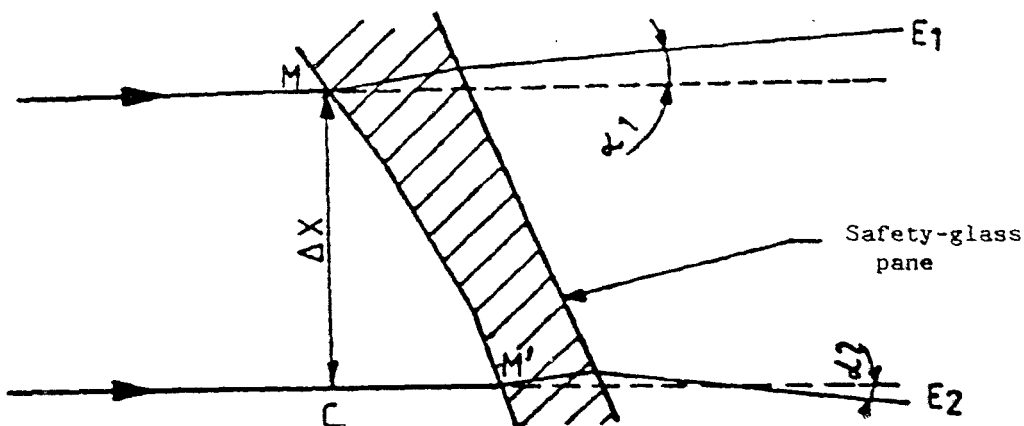

Figure 6 : Diagrammatic representation of optical distortion

NOTES :

$\Delta \alpha = \alpha_1 - \alpha_2$, i.e. the optical distortion in the direction M-M'.

$\Delta x = MC$ i.e. the distance between two straight lines parallel to the direction of vision and passing through the points M and M'.

9.2.1.2. Apparatus

This method entails the projection of an appropriate slide (raster) onto the display screen through the safety-glass pane being tested. The change caused in the shape of the projected image by the insertion of the safety-glass pane in the line of light provides a measure of the distortion.

The apparatus shall comprise the following items, arranged as shown in figure 9.

9.2.1.2.1. - Projector, of good quality, with a high-intensity point light source, having for example the following characteristics :

- focal length at least 90 mm,
- aperture approximately 1/2.5,
- 150-W quartz halogen lamp (if used without a filter),
- 250-W quartz halogen lamp (if a green filter is used).

The projector is shown schematically in figure 7. A diaphragm of 8 mm in diameter is positioned approximately 10 mm from the front lens.

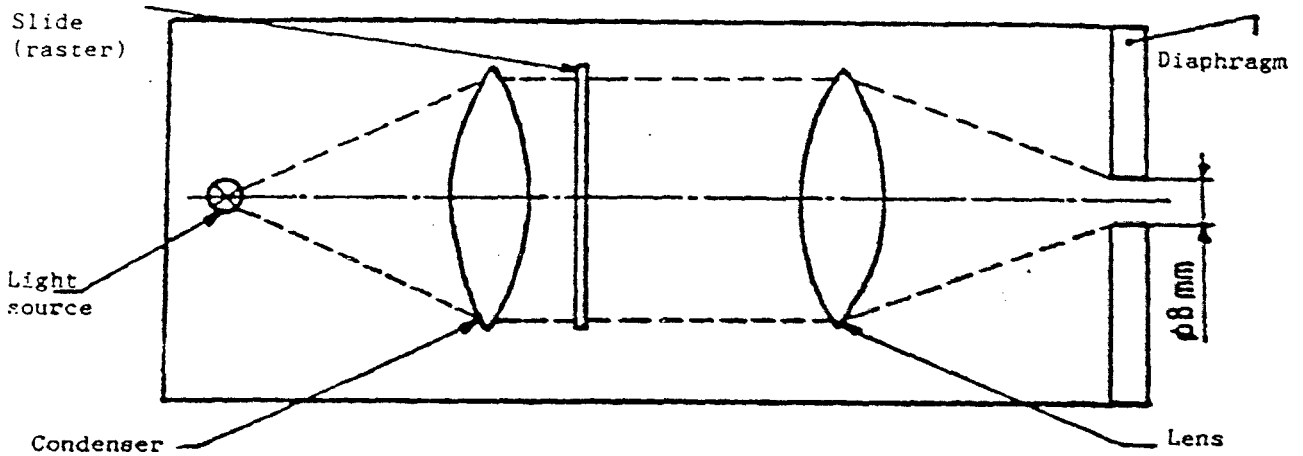

Figure 7 : Optical arrangement of the projector

9.2.1.2.2. - Slides (rasters) consisting, for example, of an array of bright circular shapes on a dark background (see figure 8). The slides shall be of sufficiently high quality and contrast to enable measurement to be carried out with an error of less than 5 per cent.

In the absence of the safety-glass pane to be examined, the dimensions of the circular shapes shall be such that when the circular shapes are projected they form an array of circles of diameter

$$\frac{R_1 + R_2}{R_1} \cdot \Delta x, \quad \text{where } \Delta x = 4 \text{ mm (see figures 6 and 9).}$$

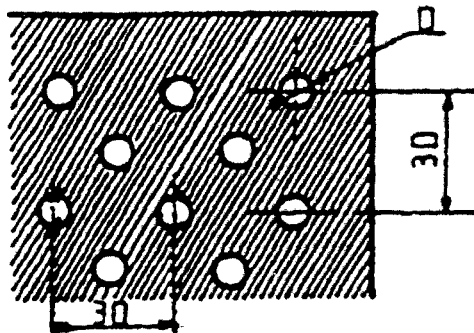

Figure 8 : Enlarged section of the slide

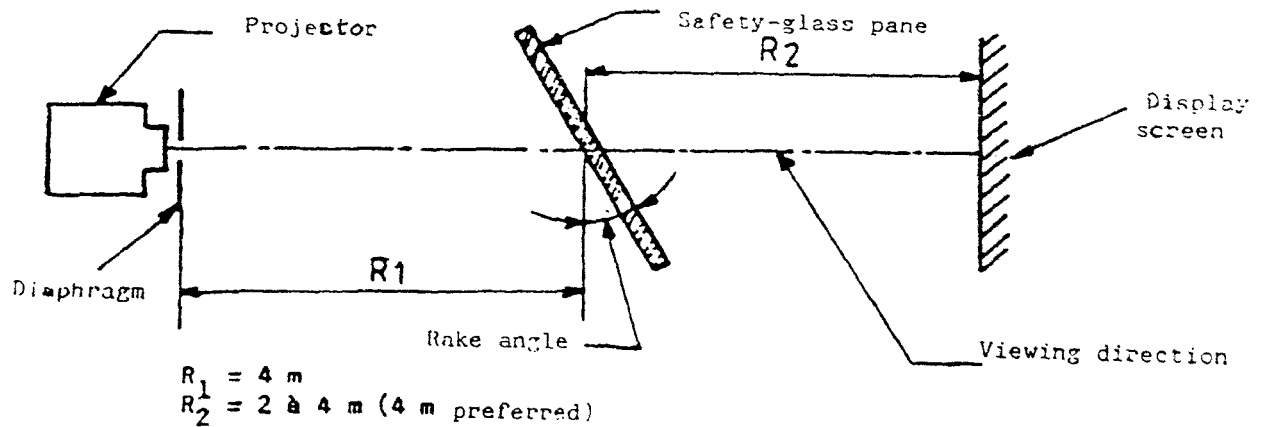

Figure 9 : Arrangement of the apparatus for the optical distortion test

- 9.2.1.2.3. - Support stand, preferably one permitting vertical and horizontal scanning, as well as rotation of the safety-glass pane.
- 9.2.1.2.4. - Checking template for measuring changes in dimensions where a rapid assessment is required. A suitable design is shown in figure 10.

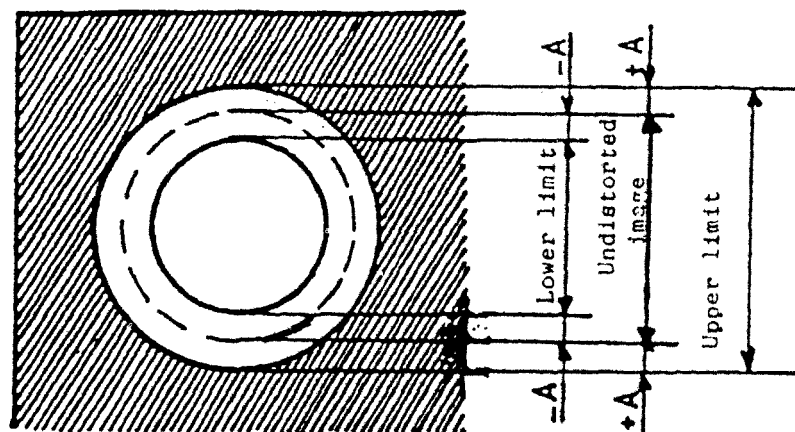

Figure 10 : Design for a suitable checking template

9.2.1.3. Procedure

9.2.1.3.1. General

Mount the safety-glass pane on the support stand (paragraph 9.2.1.2.3.) at the designed rake angle. Project the test image through the area being examined. Rotate the safety-glass pane or move it either horizontally or vertically in order to examine the whole of the specified area.

9.2.1.3.2. Assessment using a checking template

When a rapid assessment with a possible margin of error of up to 20 per cent is sufficient, calculate the value of A (see figure 10) from the limit value $\Delta \alpha L$ for the change in deviation and the value of R_2 , the distance from the safety-glass pane to the display screen :

$$A = 0.145 \Delta \alpha L \cdot R_2$$

The relationship between the change in diameter of the projected image Δd and the change in angular deviation $\Delta \alpha$ is given by

$$\Delta d = 0.29 \Delta \alpha \cdot R_2$$

where :

Δd is in millimetres,
 A is in millimetres,
 $\Delta \alpha L$ is in minutes of arc,
 $\Delta \alpha$ is in minutes of arc,
 R_2 is in metres.

9.2.1.3.3. Measurement using a photoelectric device

Where a precise measurement with a possible margin of error of less than 10 per cent of the limit value is required, measure Δd on the projection axis, the value of the spot width being taken at the point where the luminance is 0.5 times the maximum spot-luminance value.

9.2.1.4. Expression of results

Evaluate the optical distortion of the safety-glass panes by measuring Δd at any point of the surface and in all directions in order to find Δd_{\max} .

9.2.1.5. Alternative method

In addition, a strioscopic technique is permitted as an alternative to the projection techniques, provided that the accuracy of the measurements given in paragraphs 9.2.1.3.2. and 9.2.1.3.3. is maintained.

9.2.1.6. The distance Δx shall be 4 mm.

9.2.1.7. The windscreen shall be mounted at the same angle of inclination as on the vehicle.

9.2.1.8. The projection axis in the horizontal plane shall be maintained approximately normal to the trace of the windscreen in that plane.

9.2.2. The measurements shall be performed :

9.2.2.1. For vehicle category M_1 in zone A, extended to the median plane of the vehicle, and in the corresponding part of the windscreen symmetrical to it about the longitudinal median plane of the vehicle, and also in zone B.

9.2.2.2. For vehicles of categories M and N other than M₁, in zone I as defined in paragraph 9.2.5.2. of this annex.

9.2.2.3. For agricultural and forestry tractors and for construction-site vehicles for which it is not possible to determine zone I, in zone I' as defined in paragraph 9.2.5.3. of this annex.

9.2.2.4. Vehicle type
 The test shall be repeated if the windscreen is to be fitted to a vehicle of a type in which the forward field of vision differs from that of the vehicle type for which the windscreen has already been approved.

9.2.3. Indices of difficulty of the secondary characteristics

9.2.3.1. Nature of the material

	<u>Polished (plate) glass</u>	<u>Float glass</u>	<u>Sheet glass</u>
	1	1	2

9.2.3.2. Other secondary characteristics
 No other secondary characteristics are involved.

9.2.4. Number of samples
 Four samples shall be submitted for testing.

9.2.5. Definitions of zones

9.2.5.1. Zones A and B of windscreens for vehicle category M₁ are defined in annex 15 to this Regulation.

9.2.5.2. Zones of windscreens for vehicles of categories M and N other than M₁ are defined on the basis of :

9.2.5.2.1. the eye point, which is the point located 625 mm above the point R of the driver's seat in the vertical plane parallel to the longitudinal median plane of the vehicle for which the windscreen is intended, passing through the axis of the steering wheel. The eye point is hereunder designated 'O';

9.2.5.2.2. the straight line OQ which is the horizontal straight line passing through the eye point O and perpendicular to the median longitudinal plane of the vehicle.

9.2.5.2.3. Zone I is the windscreen zone determined by the intersection of the windscreen with the four planes defined below :

P1 - a vertical plane passing through O and forming an angle of 15° to the left of the median longitudinal plane of the vehicle;

P2 - a vertical plane symmetrical to P1 about the median longitudinal plane of the vehicle.

If this is not possible (in the absence of a symmetrical median longitudinal plane, for instance) P2 shall be the plane symmetrical to P1 about the longitudinal plane of the vehicle passing through point O.

P3 - a plane passing through the straight line OQ and forming an angle of 10° above the horizontal plane;

P4 - a plane passing through the straight line OQ and forming an angle of 8° below the horizontal plane.

9.2.5.3. For agricultural and forestry tractors and for construction-site vehicles for which it is not possible to determine zone I, zone I' consists in the whole surface of the windscreen.

9.2.6. Interpretation of results

A windscreen type shall be considered satisfactory with respect to optical distortion if, in the four samples submitted for testing, optical distortion does not exceed the values given below for each zone.

Vehicle category	Zone	Maximum values of optical distortion
M ₁	A. extended according to para. 9.2.2.1.	2' of arc
	B.	6' of arc
M and N categories other than M ₁	I	2' of arc
Agricultural vehicles etc. for which it is not possible to determine zone I	I'	2' of arc

9.2.6.1. For vehicles of categories M and N, no measurements shall be made in a peripheral area 25 mm wide.

9.2.6.2. For agricultural and forestry tractors and for construction-site vehicles, no measurements shall be made in a peripheral area 100 mm wide.

9.2.6.3. In the case of split windscreens, no measurements shall be made in a strip 35 mm from the edge of the pane which is to be adjacent to the dividing pillar.

9.2.6.4. A maximum value of 6' of arc is permitted for all portions of zone I or zone A which are less than 100 mm from the edge of the windscreen.

9.2.6.5. Slight deviations from the requirements may be allowed in zone B provided they are localized and recorded in the report.

9.3. Secondary-image-separation test

9.3.1. Scope

Two test methods are recognized :
 target test, and
 collimation-telescope test.

These test methods may be used for approval, quality-control or product-evaluation purposes, as appropriate.

9.3.1.1. Target test

9.3.1.1.1. Apparatus

This method involves viewing an illuminated target through the safety-glass pane. The target may be designed in such a way that the test can be carried out on a simple 'go-no go' basis.

The target shall preferably be of one of the following types; that is to say, either

- (a) an illuminated 'ring' target whose outer diameter, D , subtends an angle of n minutes of arc at a point situated at x metres (figure 11(a), or
- (b) an illuminated 'ring and spot' target whose dimensions are such that the distance D from a point on the edge of the spot to the nearest point on the inside of the circle subtends an angle of n minutes of arc at a point situated at x metres (figure 11(b), where

n is the limit value of secondary-image separation,

x is the distance from the safety-glass pane to the target (not less than 7 m),

D is given by the formula : $D = x \cdot \text{tg } n$

The illuminated target consists of a light box, approximately 300 mm x 300 mm x 150 mm, whose front is most conveniently constructed of glass masked with opaque black paper or coated with matt black paint.

The box shall be illuminated by a suitable light source. It may be convenient to use other forms of target, such as that shown in figure 14. It is also acceptable to replace the target system by a projection system and to view the resulting images on a screen.

9.3.1.1.2. Procedure

Mount the safety-glass pane at the specified rake angle on a suitable stand in such a way that the observation is carried out in the horizontal plane passing through the centre of the target.

The light box shall be viewed in a dark or semi-dark room, through each part of the area being examined, in order to detect the presence of any secondary image associated with the illuminated target.

Rotate the safety-glass pane as necessary to ensure that the correct direction of view is maintained. A monocular may be used for viewing.

9.3.1.1.3. Expression of results

Determine whether,

When target (a) (see figure 11(a)) is used, the primary and secondary images of the circle separate, i.e. whether the limit value of n is exceeded, or

When target (b) (see figure 11(b)) is used, the secondary image of the spot shifts beyond the point of tangency with the inside edge of the circle, i.e. whether the limit value of n is exceeded.

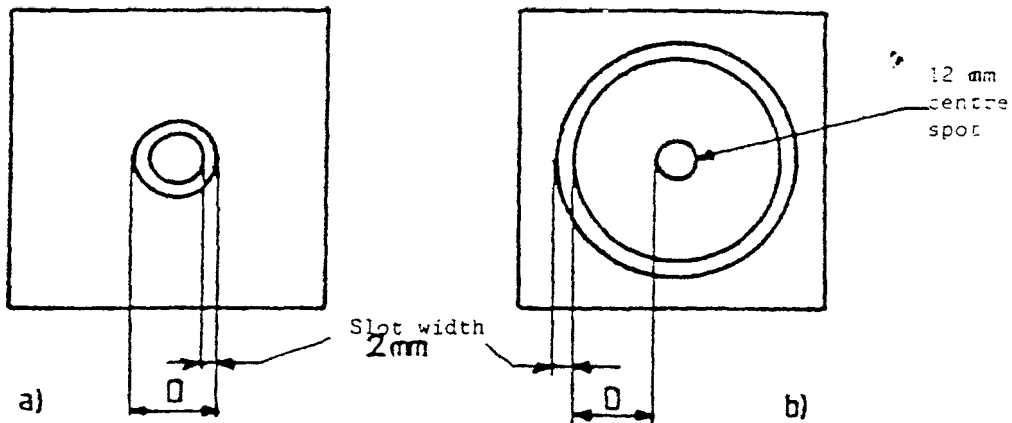

Figure 11 : Dimensions of targets

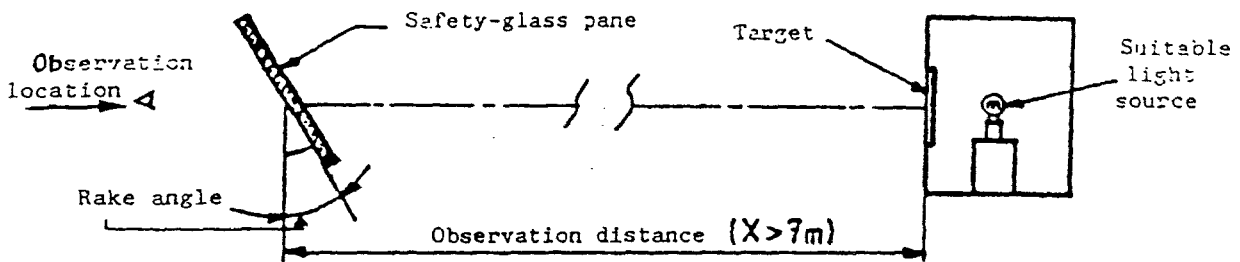
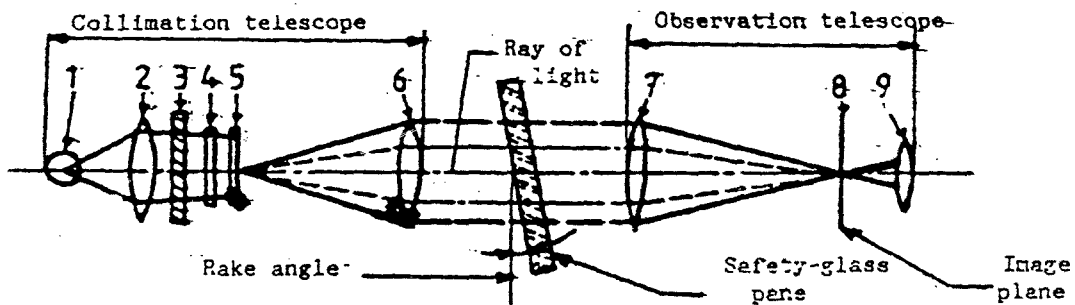

Figure 12 : Arrangement of apparatus



- (1) Lamp bulb
- (2) Condenser aperture $> 8.6 \text{ mm}$
- (3) Ground-glass screen aperture $>$ condenser aperture
- (4) Colour filter with central hole approximately 0.3 mm in diameter, diameter $> 8.6 \text{ mm}$
- (5) Polar co-ordinate plate, diameter $> 8.6 \text{ mm}$
- (6) Achromatic lens, $f \geq 86 \text{ mm}$, aperture 10 mm
- (7) Achromatic lens, $f \geq 86 \text{ mm}$, aperture 10 mm
- (8) Black spot, diameter approximately 0.3 mm
- (9) Achromatic lens, $f = 20 \text{ mm}$, aperture $< 10 \text{ mm}$.

Figure 13 : Apparatus for collimation-telescope test

9.3.1.2. Collimation-telescope test

If necessary, the procedure described in this paragraph shall be applied.

9.3.1.2.1. Apparatus

The apparatus comprises a collimator and a telescope and may be set up in accordance with figure 13. However, any equivalent optical system may be used.

9.3.1.2.2. Procedure

The collimation telescope forms at infinity the image of a polar co-ordinate system with a bright point at its centre (see figure 14).

In the focal plane of the observation telescope, a small opaque spot with a diameter slightly larger than of the projected bright point is placed on the optical axis, thus obscuring the bright point.

When a test piece which exhibits a secondary image is placed between the telescope and the collimator, a second, less bright point appears at a certain distance from the centre of the polar co-ordinate system. The secondary-image separation can be read out as the distance between the points seen through the observation telescope (see figure 14).

(The distance between the dark spot and the bright point at the centre of the polar co-ordinate system represents the optical deviation).

9.3.1.2.3. Expression of results

The safety-glass pane shall first be examined by a simple scanning technique to establish the area giving the strongest secondary image.

That area shall then be examined by the collimation-telescope system at the appropriate angle of incidence. The maximum secondary-image separation shall be measured.

9.3.1.3. The direction of observation in the horizontal plane shall be maintained approximately normal to the trace of the windscreen in that plane.

9.3.2. The measurements shall be performed in the zones as defined in paragraph 9.2.2. above according to the vehicle categories.

9.3.2.1. Vehicle type

The test shall be repeated if the windscreen is to be fitted to a vehicle of a type in which the forward field of vision differs from that of the vehicle type for which the windscreen has already been approved.

9.3.3. Indices of difficulty of the secondary characteristics

9.3.3.1. Nature of the material

<u>Polished (plate) glass</u>	<u>Float glass</u>	<u>Sheet glass</u>
1	1	2

9.3.3.2. Other secondary characteristics

No other secondary characteristics are not involved.

9.3.4. Number of samples

Four samples shall be submitted for testing.

Figure 14 : Example of observation by the collimation-telescope test method

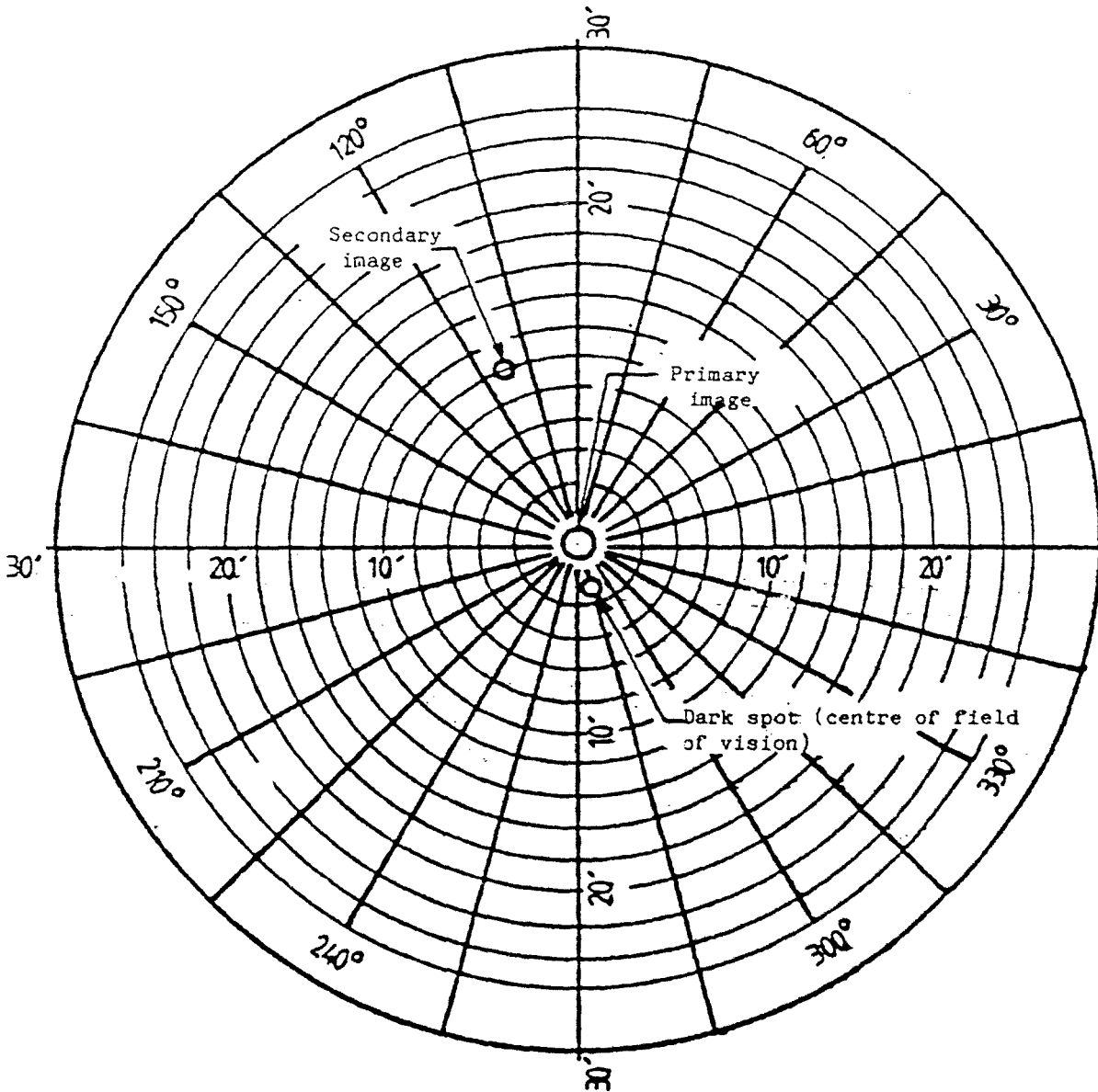

9.3.5. Interpretation of results

A windscreen type shall be considered satisfactory with respect to secondary-image separation if, in the four samples submitted for testing, separation of the primary and secondary images does not exceed the values given below for each zone.

Vehicle category	Zone	Maximum values of the separation of the primary and secondary images
M ₁	A - Extended according to para. 9.2.2.1.	15' of arc
	B	25' of arc
M and N categories other than M ₁	I	15' of arc
Agricultural vehicles etc. for which it is not possible to determine zone I	I'	15' of arc

- 9.3.5.1. For vehicles of categories M and N, no measurements shall be made in a peripheral area 25 mm wide.
- 9.3.5.2. For agricultural and forestry tractors and for construction-site vehicles, no measurements shall be made in a peripheral area 100 mm wide.
- 9.3.5.3. In the case of split windscreens, no measurements shall be made in a strip 35 mm from the edge of the glass pane which is to be adjacent to the dividing pillar.
- 9.3.5.4. A maximum value of 25' of arc is permitted for all portions of zone I or zone A which are less than 100 mm from the edge of the windscreen.
- 9.3.5.5. Slight deviations from the requirements may be allowed in zone B provided they are localized and recorded in the report.

9.4. Identification-of-colours test

When a windscreen is tinted in the zones defined in paragraphs 9.2.5.1., 9.2.5.2. or 9.2.5.3., four windscreens shall be tested for identifiability of the following colours :

white,
 selective yellow,
 red,
 green,
 blue,
 amber.

10. BURNING BEHAVIOUR (FIRE-RESISTANCE) TEST

10.1. Purpose and scope of application

This method enables the horizontal burning rate of materials used in the passenger compartment of motor vehicles (for example, private passenger cars, lorries (trucks), estate cars, motor coaches) after exposure to a small flame to be determined.

This method permits testing of materials and components of a vehicle's interior equipment individually or in combination up to a thickness of 13 mm. It is used to judge the uniformity of production lots of such materials with respect to their burning behaviour.

Because of the many differences between the real-world situation (application and orientation within a vehicle, conditions of use, ignition source, etc.) and the precise test conditions prescribed herein, this method cannot be considered as suitable for evaluation of all true in-vehicle burning characteristics.

10.2. Definitions

- 10.2.1. Burning rate : The quotient of the burnt distance measured according to this method and the time taken to burn that distance.
It is expressed in millimetres per minute.
- 10.2.2. Composite material : A material composed of several layers of similar or different materials intimately held together at their surfaces by cementing, bonding, cladding, welding, etc.
When different materials are connected together intermittently (for example, by sewing, high-frequency-welding, riveting), then in order to permit the preparation of individual samples in accordance with paragraph 10.5. below such materials shall not be considered as composite materials.
- 10.2.3. Exposed side : The side which is facing towards the passenger compartment when the material is mounted in the vehicle.

10.3. Principle

A sample is held horizontally in a U-shaped holder and is exposed to the action of a defined low-energy flame for 15 seconds in a combustion chamber, the flame acting on the free end of the sample.
The test determines whether and when the flame is extinguished or the time which the flame requires to proceed over a measured distance.

10.4. Apparatus

- 10.4.1. Combustion chamber (figure 15), preferably of stainless steel, having the dimensions given in figure 16.
The front of the chamber contains a flame-resistant observation window, which may cover the entire front and which can be constructed as an access panel.
The bottom of the chamber has vent holes, and the top has a vent slot all around.

The combustion chamber is placed on four feet, 10 mm high. The chamber may have a hole at one end for the introduction of the sample holder containing the sample; in the opposite end, a hole is provided for the gas-supply line. Melted material is caught in a pan (see figure 17) which is placed on the bottom of the chamber between vent holes without covering any vent hole area.

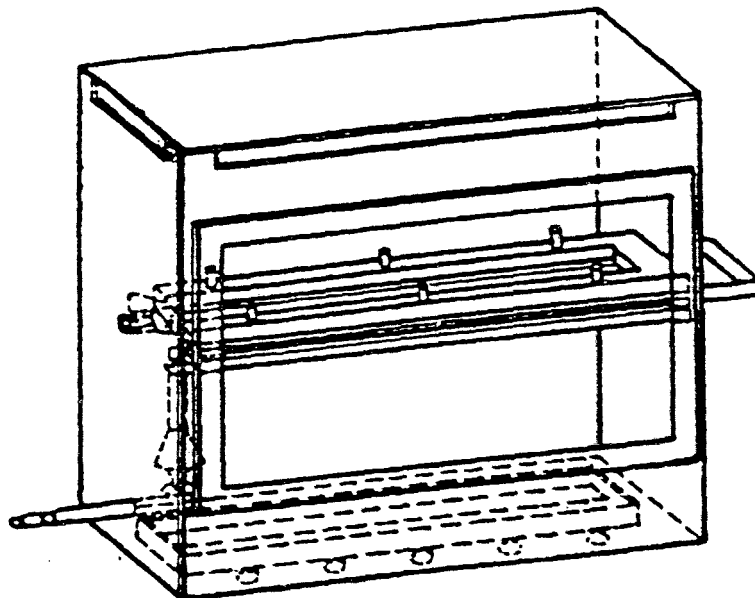

Figure 15 : Example of combustion chamber with sample holder and drip pan

- 10.4.2. Sample holder, consisting of two U-shaped metal plates or frames of corrosion-proof material. Dimensions are given in figure 18.

The lower plate is equipped with pins and the upper one with corresponding holes, in order to ensure a consistent holding of the sample. The pins also serve as measuring points at the beginning and end of the burning distance.

A support shall be provided in the form of heat-resistant wires 0.25 mm in diameter spanning the frame at 25-mm intervals over the bottom U-shaped frame (see figure 19).

The plane of the lower side of samples shall be 178 mm above the floor plate. The distance of the front edge of the sample holder from the end of the chamber shall be 22mm; the distance of the longitudinal sides of the sample holder from the sides of the chamber shall be 50 mm (all inside dimensions). (See figures 15 and 16).

- 10.4.3. Gas burner
The small ignition source is provided by a Bunsen burner having an inside diameter of 9.5 mm. It is so located in the test cabinet that the centre of its nozzle is 19 mm below the centre of the bottom edge of the open end of the sample (see figure 16).
- 10.4.4. Test gas
The gas supplied to the burner shall have a calorific value of about 38 MJ/m³ (for example natural gas).

Dimensions in millimetres
 Tolerances according to ISO 2768

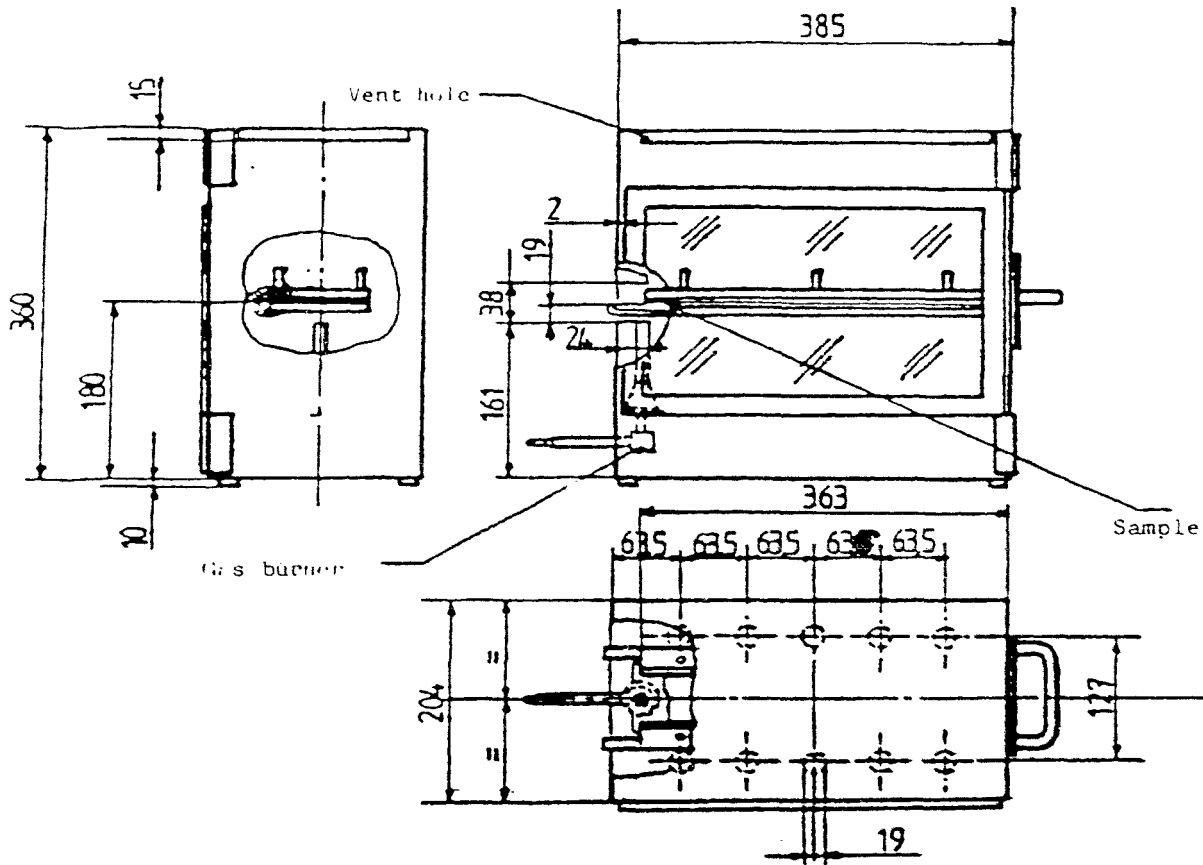

Figure 16 : Example of combustion chamber

Dimensions in millimetres.
 Tolerances according to ISO 2768

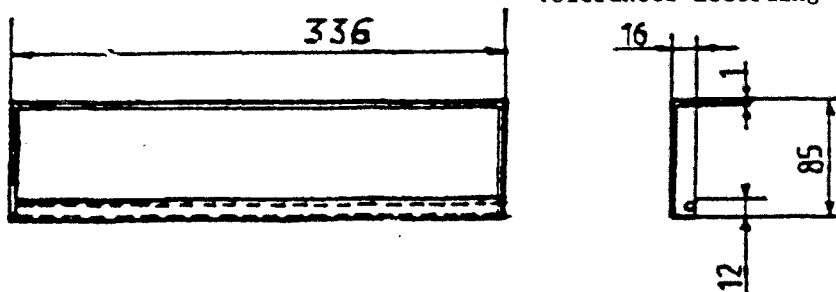

Figure 17 : Typical drip pan

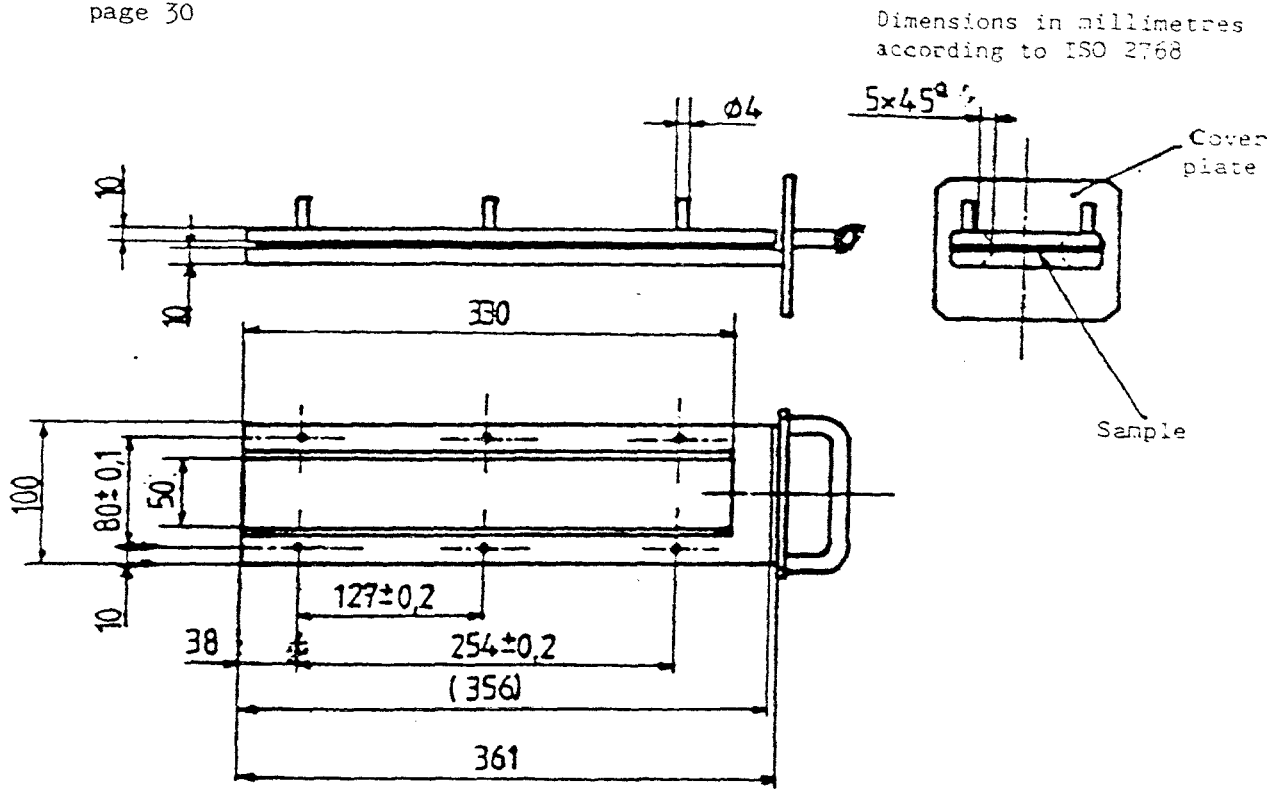

Figure 18 : Example of sample holder

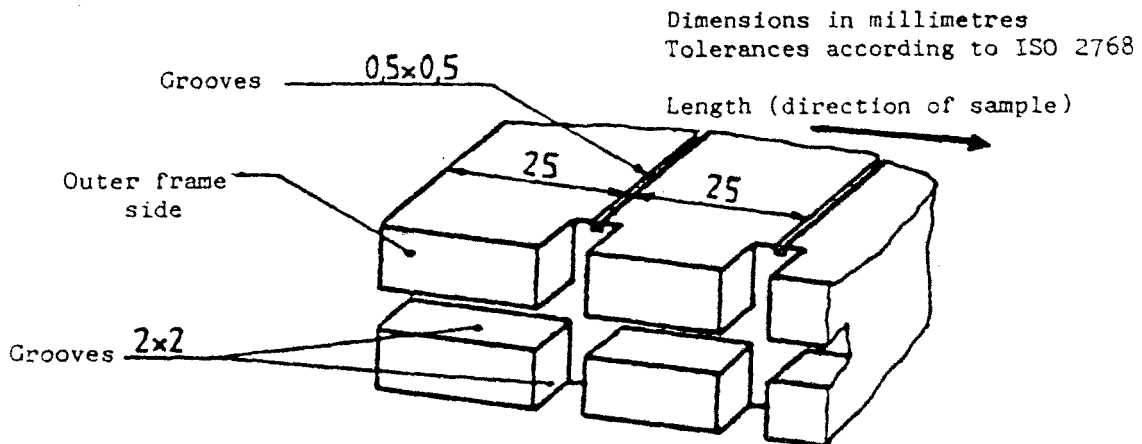

Figure 19 : Example of section of lower U-frame design
for wire support facility

- 10.4.5. Metal comb, at least 110 mm in length, with seven or eight smooth rounded teeth per 25 mm.
- 10.4.6. Stop-watch, accurate to 0.5 sec.

10.4.7. Fume cupboard

The combustion chamber may be placed in a fume-cupboard assembly provided that the latter's internal volume is at least 20 times, but not more than 110 times, greater than the volume of the combustion chamber and provided that no single height, width, or length dimension of the fume cupboard is greater than 2.5 times either of the other two dimensions.

Before the test, the vertical velocity of the air through the fume cupboard shall be measured 100 mm forward of and to the rear of the ultimate site of the combustion chamber. It shall be between 0.10 and 0.30 m/s in order to avoid possible discomfort to the operator from combustion products. It is possible to use a fume cupboard with natural ventilation and an appropriate air velocity.

10.5. Samples

10.5.1. Shape and dimensions

The shape and dimensions of samples are given in figure 20. The thickness of the sample corresponds to the thickness of the product to be tested. It shall not be more than 13 mm. When sample-taking so permits, the sample shall have a constant section over its entire length.

When the shape and dimensions of a product do not permit taking a sample of the given size, the following minimum dimensions shall be observed :

- (a) for samples having a width of 3 to 60 mm, the length shall be 356 mm. In this case the material is tested over the product's width;
- (b) for samples having a width of 60 to 100 mm, the length shall be at least 138 mm. In this case the potential burning distance corresponds to the length of the sample, the measurement starting at the first measuring point;
- (c) samples less than 60 mm wide and less than 356 mm long, and samples 60 to 100 mm wide and less than 138 mm long, cannot be tested according to the present method, nor can samples less than 3 mm wide.

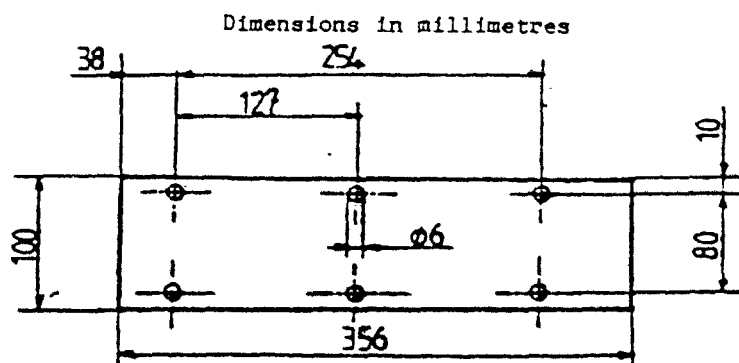

Figure 20 : Sample

10.5.2. Sampling

At least five samples shall be taken from the material under test. In materials having burning rates differing according to the direction of the material (this being established by preliminary tests) the five (or more) samples shall be taken and be placed in the test apparatus in such a way that the highest burning rate will be measured.

When the material is supplied in set widths, a length of at least 500 mm covering the entire width shall be cut. From the piece so cut, the samples shall be taken at not less than 100 mm from the edge of the material and at points equidistant from each other.

Samples shall be taken in the same way from finished products when the shape of the product so permits. If the thickness of the product is over 13 mm it shall be reduced to 13 mm by a mechanical process applied to the side which does not face the passenger compartment.

Composite materials (see paragraph 10.2.2.) shall be tested as if they were homogeneous.

In the case of materials comprising superimposed layers of different composition which are not composite materials, all the layers of material included within a depth of 13 mm from the surface facing towards the passenger compartment shall be tested individually.

10.5.3. Conditioning

The samples shall be conditioned for at least 24 hours, but not more than 7 days, at a temperature of $23 \pm 2^\circ\text{C}$ and a relative humidity of 50 ± 5 per cent, and shall be maintained under these conditions until immediately prior to testing.

10.6. Procedure

- 10.6.1. Place samples with napped or tufted surfaces on a flat surface, and comb twice against the nap using the comb (paragraph 10.4.5.).
- 10.6.2. So place the sample in the sample holder (paragraph 10.4.2.) that the exposed side faces downwards, towards the flame.
- 10.6.3. Adjust the gas flame to a height of 38 mm using the mark in the chamber, the air intake of the burner being closed. The flame shall burn for at least one minute, for stabilization, before the first test is started.
- 10.6.4. Push the sample holder into the combustion chamber so that the end of the sample is exposed to the flame, and after 15 seconds cut off the gas flow.
- 10.6.5. Measurement of burning time starts at the moment when the foot of the flame passes the first measuring point. Observe the flame propagation on the side (upper or lower) which burns faster.
- 10.6.6. Measurement of burning time is completed when the flame has come to the last measuring point or when the flame is extinguished before reaching that point. If the flame does not reach the last measuring point, measure the burnt distance up to the point where the flame was extinguished. Burnt distance is the part of the sample destroyed, on the surface or inside, by burning.

- 10.6.7. If the sample does not ignite or does not continue burning after the burner has been extinguished, or the flame goes out before reaching the first measuring point, so that no burning time is measured, note in the test report that the burning rate is 0 mm/min.
- 10.6.8. When running a series of tests or performing repeat tests, make sure before starting a test that the temperature of the combustion chamber and sample holder does not exceed 30°C.

10.7. Calculation

The burning rate B, in millimetres per minute, is given by the formula :

$$B = \frac{s}{t} \times 60$$

where:

s is the burnt distance, in millimetres,
t is the time, in seconds, taken to burn the distance s.

10.8. Indices of difficulty of the secondary characteristics

No secondary characteristics are involved.

10.9. Interpretation of results

Safety-glass panes faced with plastics material (paragraph 2.3. of this Regulation) and glass-plastics safety panes (paragraph 2.4. of this Regulation) shall be considered satisfactory from the point of view of the fire-resistance test if the burn rate does not exceed 250 mm/min.

11. TEST OF RESISTANCE TO CHEMICALS

11.1. Chemicals used for the test

- 11.1.1. Non-abrasive soap solution : 1 per cent by weight of potassium oleate in deionized water;
- 11.1.2. Window-cleaning solution : an aqueous solution of isopropanol and dipropylene glycol monomethyl ether in concentration between 5 and 10 per cent by weight each and ammonium hydroxide in concentration between 1 and 5 per cent by weight;
- 11.1.3. Undiluted denatured alcohol : 1 part by volume methyl alcohol in 10 parts by volume ethyl alcohol;
- 11.1.4. Reference petrol : a mixture of 50 per cent by volume toluene, 30 per cent by volume 2,2,4-trimethylpentane, 15 per cent by volume 2,4,4-trimethyl-1-pentene and 5 per cent by volume ethyl alcohol;
- 11.1.5. Reference kerosene : a mixture of 50 per cent by volume n-octane and 50 per cent by volume n-decane.

11.2. Test method

Two test pieces 180 x 25 mm shall be tested with each of the chemicals specified in paragraph 11.1. above, using a new test piece for each test and each cleaning product.

Before each test, test pieces shall be cleaned according to the manufacturer's instructions, then conditioned for 48 hours at a temperature of $23^{\circ}\text{C} \pm 2^{\circ}\text{C}$ and a relative humidity of 50 per cent \pm 5 per cent. These conditions shall be maintained throughout the tests.

The test pieces shall be completely immersed in the test fluid and held for one minute, then removed and immediately wiped dry with a clean absorbent cotton cloth.

11.3. Indices of difficulty of the secondary characteristics

	<u>Colourless</u>	<u>Tinted</u>
Colouring of the interlayer or of the plastics coating	1	2

The other secondary characteristics are not concerned.

11.4. Interpretation of results

11.4.1. The test for resistance to chemical agents shall be considered to have given a satisfactory result if the test piece does not exhibit any softening, tackiness, crazing or apparent loss of transparency.

11.4.2. A set of test pieces shall be considered satisfactory with regard to the test for resistance to chemical agents if one of the following conditions is met :

11.4.2.1. All the tests have given a satisfactory result;

11.4.2.2. One test having given an unsatisfactory result, a new series of tests carried out on a new set of test pieces has given a satisfactory result.

Annex 4

TOUGHENED-GLASS WINDSCREENS

1. DEFINITION OF TYPE

Toughened-glass windscreens shall be deemed to belong to different types if they differ in at least one of the following principal or secondary characteristics.

1.1. The principal characteristics are as follows :

1.1.1. The trade name or mark;

1.1.2. The shape and dimensions.
Toughened-glass windscreens shall be considered as belonging to one or other of two groups for the purposes of fragmentation and mechanical-properties test, i.e.;

1.1.2.1. flat windscreens, and

1.1.2.2. curved windscreens.

1.1.3. The thickness category in which the nominal thickness 'e' lies (a manufacturing tolerance of +/- 0.2 mm being allowed) :

Category I $e \leq 4.5 \text{ mm}$
Category II $4.5 \text{ mm} < e \leq 5.5 \text{ mm}$
Category III $5.5 \text{ mm} < e \leq 6.5 \text{ mm}$
Category IV $6.5 \text{ mm} < e$

1.2. The secondary characteristics are as follows :

1.2.1. Nature of the material (polished (plate) glass, float glass, sheet glass);

1.2.2. Colouring (colourless or tinted);

1.2.3. The incorporation or otherwise of conductors;

1.2.4. The incorporation or otherwise of obscuration bands.

2. FRAGMENTATION TEST

2.1. Indices of difficulty of the secondary characteristics

2.1.1. Only the nature of the material is involved.

2.1.2. Float glass and sheet glass are considered to have the same index of difficulty.

2.1.3. The fragmentation tests must be repeated on transition from polished (plate) glass to float glass or sheet glass, and vice versa.

2.1.4. The tests must be repeated if obscuration bands other than painted bands are used.

2.2. Number of samples

Six samples from the smallest-developed-area series and six samples from the largest-developed-area series, selected as prescribed in annex 13, shall be tested.

2.3. Different zones of glass

A toughened-glass windscreen shall comprise two main zones, FI and FII. It may also comprise an intermediate zone, FIII. These zones are as defined below.

2.3.1. Zone FI : Peripheral zone of fine fragmentation, at least 7 cm wide, all round the edge of the windscreen and including an outer strip 2 cm wide not subjected to assessment;

2.3.2. Zone FII : Visibility zone of varying fragmentation, always including a rectangular part at least 20 cm high and 50 cm long;

2.3.2.1. For vehicles of category M₁, the centre of the rectangle shall be inside a circle having a radius of 10 cm centred on the projection of the middle of segment V1-V2.

2.3.2.2. For vehicles of categories M and N other than M₁, the centre of the rectangle shall be inside a circle having a radius of 10 cm centred on the projection of point O;

2.3.2.3. For agricultural and forestry tractors and for construction-site vehicles, the position of the visibility zone shall be indicated in the test report.

2.3.2.4. The height of the above rectangle may be reduced to 15 cm for windscreens which are less than 44 cm high.

2.3.3. Zone FIII: Intermediate zone, not more than 5 cm wide, between zones FI and FII.

2.4. Test method

The method used shall be that described in annex 3, paragraph 1.

2.5. Points of impact (see annex 14, figure 2)

2.5.1. The points of impact shall be selected as follows :

Point 1 : in the central part of zone FII in an area of high or low stress,

Point 2 : in zone FIII, as near as possible to the vertical plane of symmetry of zone FII,

Points 3 and 3' : 3 cm from the edges of one median of the sample; when there is a tong mark, one of the breakage points shall be near the edge bearing the tong mark and the other near the opposite edge,

Point 4 : at the place where the radius of curvature is smallest on the longest median,

Point 5 : 3 cm from the edge of the sample at the place where the radius of curvature of the edge is smallest, either to the left or to the right.

2.5.2. A fragmentation test shall be performed at each of the points 1, 2, 3, 3', 4 and 5.

2.6. Interpretation of results

2.6.1. A test shall be deemed to have given a satisfactory result if fragmentation satisfies all the conditions given in paragraphs 2.6.1.1., 2.6.1.2. and 2.6.1.3. below.

2.6.1.1. Zone FI :

2.6.1.1.1. The number of fragments in any 5 cm x 5 cm square is not less than 40 nor more than 350; however in the case of a count of less than 40, if the number of fragments in any 10 cm x 10 cm square containing the 5 cm x 5 cm square is not less than 160, this shall be acceptable.

2.6.1.1.2. For the purposes of the above rule, a fragment extending across a side of a square shall count as half a fragment.

2.6.1.1.3. Fragmentation shall not be checked in a strip 2 cm wide round the edge of the samples, this strip representing the frame of the glass, nor within a radius of 7.5 cm from the point of impact.

2.6.1.1.4. A maximum of 3 fragments of an area exceeding 3 cm² shall be allowed. No two of these fragments shall be contained within the same 10 cm diameter circle.

2.6.1.1.5. Elongated fragments may be permitted provided that their ends are not knife-edged and that their length does not exceed 7.5 cm, except in the case provided for in paragraph 2.6.2.2. below. If these elongated fragments extend to the edge of the glass, they must not form an angle of more than 45° with it.

2.6.1.2 Zone FII:

2.6.1.2.1. The residual visibility after shattering shall be checked in the rectangular area defined in paragraph 2.3.2. above. In that rectangle the aggregate surface area of the fragments of more than 2 cm² shall represent not less than 15 per cent of the area of the rectangle; however, in the case of windscreens less than 44 cm high, or whose angle of installation is less than 15° from the vertical, the visibility percentage shall at least be equal to 10 per cent of the surface of the corresponding rectangle.

2.6.1.2.2. No fragment shall have an area of more than 16 cm² except in the case provided for in paragraph 2.6.2.2. below.

2.6.1.2.3. Within a radius of 10 cm from the point of impact, but only in that part of the circle which is included in Zone FII, three fragments having an area of more than 16 cm² but less than 25 cm² shall be allowed.

2.6.1.2.4. Fragments shall be substantially regular in shape and free from points of the type described in paragraph 2.6.1.2.4.1. below. However, not more than 10 irregular fragments shall be allowed in any 50 x 20 cm rectangle and not more than 25 over the whole surface of the windscreen.

No such fragment shall present a point more than 35 mm long measured in accordance with paragraph 2.6.1.2.4.1. below.

- 2.6.1.2.4.1. A fragment shall be considered as an irregular fragment if it cannot be inscribed in a circle of 40 mm in diameter, if it has at least one point more than 15 mm long when measured from the top of the point to the section whose width is equal to the glazing thickness, and if it has one or more points having a top angle smaller than 40°.
- 2.6.1.2.5. - Fragments of elongated shape shall be allowed in Zone FII as a whole, provided they do not exceed 10 cm in length, except in the case provided for in paragraph 2.6.2.2. below.

2.6-1.3. ZONE FIII

Fragmentation in this zone must have characteristics intermediate between those of the fragmentations respectively allowed for the two neighbouring zones (FI and FII).

- 2.6.2. A windscreen submitted for approval shall be considered satisfactory from the point of view of fragmentation if at least one of the following conditions is fulfilled :

2.6.2.1. When all the tests carried out using the points of impact defined in paragraph 2.5.1. above have given a satisfactory result;

2.6.2.2. When one test among all those carried out using the points of impact prescribed in paragraph 2.5.1. has given an unsatisfactory result, taking account of deviations which do not exceed the following limits :

Zone FI : not more than five fragments between 7.5 and 15 cm long,

Zone FII : not more than three fragments of between 16 and 20 cm² in area located outside the circle having a radius of 10 cm centred on the point of impact,

Zone FIII : not more than four fragments between 10 and 17.5 cm long

and is repeated on a new sample, which either conforms to the requirements of paragraph 2.6.1. or presents deviations within the above specified limits.

2.6.2.3. When two tests among all the tests carried out using the points of impact prescribed in paragraph 2.5.1. have given an unsatisfactory result for deviations not exceeding the limits specified in paragraph 2.6.2.2., and a further series of tests carried out on a new set of samples conforms to the requirements of paragraph 2.6.1., or not more than two samples of the new set present deviations within the above specified limits of paragraph 2.6.2.2..

2.6.3. If the above-mentioned deviations are found, they shall be noted in the test report and photographs of the relevant parts of the windscreen shall be attached to the report.

3. HEADFORM TEST

3.1. Indices of difficulty of the secondary characteristics

No secondary characteristic is involved.

3.2. Number of samples

- 3.2.1. For each group of toughened-glass windscreens, four samples having approximately the smallest developed area and four samples having approximately the largest developed area, all eight samples being of the same types as those selected for the fragmentation tests (see paragraph 2.2. above), shall be subjected to testing.
- 3.2.2. Alternatively, at the discretion of the laboratory conducting the tests, for each category of windscreen thickness, six test pieces of the dimension (1,100 mm x 500 mm) $\pm \frac{5}{2}$ mm shall be subjected to testing.

3.3. Test method

- 3.3.1. The method used shall be that described in annex 3, paragraph 3.
- 3.3.2. The height of drop shall be 1.5 m $\pm \frac{0}{5}$ mm.

3.4. Interpretation of results

- 3.4.1. The test shall be deemed to have given a satisfactory result if the windscreen or the test piece is fractured.
- 3.4.2. A set of samples submitted for approval shall be considered satisfactory from the point of view of the headform test if either of the two following conditions is fulfilled, that is to say if :
- 3.4.2.1. all the tests have given a satisfactory result;
- 3.4.2.2. one test having given an unsatisfactory result, a further series of tests carried out on a new set of samples has given satisfactory results.

4. OPTICAL QUALITIES

The requirements concerning optical qualities set out in annex 3, paragraph 9, shall apply to every type of windscreen.

Annex 5

UNIFORMLY-TOUGHENED GLASS PANES ^{*/}

1. DEFINITION OF TYPE

Uniformly-toughened glass panes shall be deemed to belong to different types if they differ in at least one of the following principal or secondary characteristics.

1.1. The principal characteristics are as follows :

1.1.1. The trade name or mark;

1.1.2. The nature of the toughening process (thermal or chemical);

1.1.3. The shape category; two categories are distinguished :

1.1.3.1. Flat glass panes,

1.1.3.2. Flat and curved glass panes.

1.1.4. The thickness category in which the nominal thickness 'e' lies (a manufacturing tolerance of ± 0.2 mm being allowed) :

Category I $e \leq 3.5$ mm

Category II $3.5\text{mm} < e \leq 4.5$ mm

Category III $4.5\text{mm} < e \leq 6.5$ mm

Category IV $6.5\text{mm} < e$

1.2. The secondary characteristics are as follows :

1.2.1. Nature of the material (polished (plate) glass, float glass, sheet glass);

1.2.2. Colouring (colourless or tinted);

1.2.3. The incorporation or otherwise of conductors.

2. FRAGMENTATION TEST

2.1. Indices of difficulty of the secondary characteristics

Material	Index of difficulty
Plate glass	2
Float glass	1
Sheet glass	1

No other secondary characteristics are involved.

^{*/} This type of uniformly-toughened glass pane can also be used for windscreens for slow-moving vehicles which, by construction, cannot exceed 30 km/h.

2.2. Selection of samples

2.2.1. Samples of each shape category and of each thickness category difficult to produce shall be selected according to the following criteria for testing.

2.2.1.1. In the case of flat glass panes, two sets of samples shall be provided, corresponding to :

2.2.1.1.1. the largest developed area,

2.2.1.1.2. the smallest angle between two adjacent sides.

2.2.1.2. In the case of flat and curved glass panes, three sets of samples shall be provided, corresponding to :

2.2.1.2.1. the largest developed area,

2.2.1.2.2. the smallest angle between two adjacent sides,

2.2.1.2.3. the largest height of segment.

2.2.2. Tests carried out on samples corresponding to the largest area 'S' shall be considered to be applicable to any other area smaller than S + 5 per cent.

2.2.3. If the samples submitted present an angle γ smaller than 30°, the tests shall be considered as applicable to all glass panes produced having an angle greater than $\gamma - 5^\circ$.

If the samples submitted present an angle γ greater than or equal to 30°, the tests shall be considered as applicable to all glass panes produced having an angle equal to or greater than 30°.

2.2.4. If the height of segment h of the samples submitted is greater than 100 mm, the tests shall be considered as applicable to all glass panes produced having a height of segment smaller than h + 30 mm.

If the height of segment of the samples submitted is less than or equal to 100 mm, the tests shall be considered as applicable to all glass panes having a height of segment less than or equal to 100 mm.

2.3. Number of samples per set

The number of samples in each group shall be as follows, according to the shape category defined in paragraph 1.1.3. above :

Kind of glass pane	Number of samples
Flat (2 sets)	4
Flat and curved (3 sets)	5

2.4. Test method

2.4.1. The method used shall be that described in annex 3, paragraph 1.

2.5. Points of impact (see annex 14, figure 3)

2.5.1. For flat glass panes and curved glass panes the points of impact represented respectively in annex 14, figures 3(a) and 3(b) on the one hand, and in annex 14, figure 3(c) on the other hand, shall be as follows :

- Point 1 : 3 cm from the edges of the glass pane in the part where the radius of curvature of the edge is smallest;
- Point 2 : 3 cm from the edge of one of the medians, the side (if any) of the glass pane bearing tong marks being selected;
- Point 3 : in the geometric centre of the glass
- Point 4 : for curved glass panes only; this point shall be selected on the largest median in that part of the pane where the radius of curvature is smallest.

2.5.2. Only one test shall be carried out at each prescribed point of impact.

2.6. Interpretation of results

2.6.1. A test shall be deemed to have given a satisfactory result if fragmentation satisfies the following conditions :

2.6.1.1. The number of fragments in any 5 cm x 5 cm square is not less than 40 or more than 400, or in the case of glazing not more than 3.5 mm thick, 450.

2.6.1.2. For the purposes of the above rule, a fragment extending across a side of a square shall count as half a fragment.

2.6.1.3. Fragmentation shall not be checked in a strip 2 cm wide round the edge of the samples, this strip representing the frame of the glass; nor within a radius of 7.5 cm from the point of impact.

2.6.1.4. Fragments of an area exceeding 3 cm² shall not be allowed except in the parts defined in paragraph 2.6.1.3. above.

2.6.1.5. A few fragments of elongated shape shall be allowed, provided that :

- their ends are not knife-edged,
- if they extend to the edge of the glass pane they do not form an angle of more than 45° with it,

and if, except in the case provided for in paragraph 2.6.2.2. below,

- their length does not exceed 7.5 cm.

2.6.2. A set of samples submitted for approval shall be considered satisfactory from the point of view of fragmentation if at least one of the following conditions is fulfilled :

2.6.2.1. When all tests carried out using the points of impact prescribed in paragraph 2.5.1. above have given a satisfactory result;

2.6.2.2. When one test among all those carried out using the points of impact prescribed in paragraph 2.5.1. has given an unsatisfactory result, taking account of deviations which do not exceed the following limits :

not more than 5 fragments between 6 and 7.5 cm long,
 not more than 4 fragments between 7.5 and 10 cm long,

and is repeated on a new sample which either conforms to the requirements of paragraph 2.6.1. or presents deviations within the above specified limits.

- 2.6.2.3. When two tests among all the tests carried out using the points of impact prescribed in paragraph 2.5.1. have given an unsatisfactory result, taking account of deviations not exceeding the limits specified in paragraph 2.6.2.2., and a further series of tests carried out on a new set of samples conforms to the prescriptions of paragraph 2.6.1. or not more than two samples of the new set present deviations within the above specified limits of paragraph 2.6.2.2..
- 2.6.3. If the above-mentioned deviations are found, they shall be noted in the test report and photographs of the relevant parts of the glass pane shall be attached to the report.

3. MECHANICAL STRENGTH TEST

3.1. 227 g ball test

3.1.1. Indices of difficulty of the secondary characteristics.

Material	Index of difficulty	Colouring	Index of difficulty
Polished glass	2	colourless	1
Float glass	1	tinted	2
Sheet glass	1		

The other secondary characteristic (namely, incorporation or otherwise of conductors) is not involved.

- 3.1.2. Number of test pieces
 Six test pieces shall be subjected to testing for each thickness category defined in paragraph 1.1.4. above.
- 3.1.3. Test method
- 3.1.3.1. The test method used shall be that described in annex 3, paragraph 2.1..
- 3.1.3.2. The height of drop (from the underface of the ball to the upper surface of the test piece) shall be as indicated in the following table, according to thickness of the glass pane :

Nominal thickness of glass pane (e)	Height of drop
$e \leq 3.5 \text{ mm}$	2.0 m + 5 - 0 mm
$3.5 \text{ mm} < e$	2.5 m + 5 - 0 mm

3.1.4. Interpretation of results

- 3.1.4.1. The test shall be deemed to have given a satisfactory result if the test piece does not break.
- 3.1.4.2. A set of test pieces submitted for approval shall be considered satisfactory from the point of view of mechanical strength if at least one of the following conditions is fulfilled :
 - 3.1.4.2.1. When not more than one test has given an unsatisfactory result,
 - 3.1.4.2.2. When two tests having given unsatisfactory results, a further series of tests carried out on a new set of six test pieces give satisfactory results.

4. OPTICAL QUALITIES

- 4.1. The provisions concerning regular light transmittance set out in annex 3, paragraph 9.1., shall apply to uniformly-toughened glass panes or parts of glass panes other than windscreens located at places which are essential to the driver's vision.
 - 4.2. The provisions of paragraph 9 of annex 3 shall apply to uniformly-toughened glass panes used as windscreens of slow-moving vehicles which, by construction, cannot exceed 30 km/h.
-

Annex 6

ORDINARY LAMINATED-GLASS WINDSCREENS

1. DEFINITION OF TYPE

Ordinary laminated-glass windscreens shall be deemed to belong to different types if they differ in at least one of the following principal or secondary characteristics.

1.1. The principal characteristics are as follows :

1.1.1. The trade name or mark,

1.1.2. The shape and dimensions,
Ordinary laminated-glass windscreens shall be deemed to belong to one group for the purposes of tests of mechanical properties and of resistance to the environment.

1.1.3. The number of layers of glass,

1.1.4. The nominal thickness 'e' of the windscreen, a manufacturing tolerance of 0.2 n mm ('n' being the number of layers of glass in the windscreen) above or below the nominal value being allowed,

1.1.5. The nominal thickness of the interlayer or interlayers,

1.1.6. The nature and type of the interlayer or interlayers (e.g. PVB or other plastics-material interlayer or interlayers).

1.2. The secondary characteristics are as follows :

1.2.1. The nature of the material (polished (plate) glass, float glass, sheet glass),

1.2.2. The colouring (total or partial) of the interlayer or interlayers (colourless or tinted),

1.2.3. The colouring of the glass (colourless or tinted),

1.2.4. The incorporation or otherwise of conductors,

1.2.5. The incorporation or otherwise of obscuration bands.

2. GENERAL

2.1. In the case of ordinary laminated-glass windscreens, tests other than headform tests (paragraph 3.2. below) and tests of optical qualities shall be conducted on flat test pieces which are either cut from actual windscreens or are specially made for the purpose. In either case the test pieces shall be in all respects rigorously representative of the serially-produced windscreens for which approval is sought.

- 2.2. Before each test the test pieces shall be stored for not less than four hours at a temperature of $23^{\circ} \pm 2^{\circ}\text{C}$. The tests shall take place as soon as possible after the test pieces have been taken out of the receptacle in which they were stored.
3. HEADFORM TEST
- 3.1. Indices of difficulty of the secondary characteristics
No secondary characteristic is involved.
- 3.2. Headform test on a complete windscreen
- 3.2.1. Number of samples
Four samples from the smallest-developed-area series and four samples from the largest-developed-area series; selected in accordance with the provisions of annex 13, shall be tested.
- 3.2.2. Test method
- 3.2.2.1. The method used shall be that described in annex 3, paragraph 3.3.2..
- 3.2.2.2. The drop height shall be $1.5 \text{ m} \pm \frac{0}{5} \text{ mm}$.
- 3.2.3. Interpretation of results
- 3.2.3.1. This test shall be deemed to have given a satisfactory result if the following conditions are fulfilled :
- 3.2.3.1.1. The sample breaks displaying numerous circular cracks centred approximately on the point of impact, the cracks nearest to the point of impact being not more than 80 mm from it;
- 3.2.3.1.2. The layers of glass shall remain adhering to the plastics-material interlayer. One or more partial separation from the interlayer with a distance of less than 4 mm in breadth, on either side of the crack, is permitted outside a circle of 60 mm in diameter centred on the point of impact.
- 3.2.3.1.3. On the impact side :
- 3.2.3.1.3.1. The interlayer must not be laid bare over an area of more than 20 cm²,
- 3.2.3.1.3.2. A tear in the interlayer up to a length of 35 mm is allowed.
- 3.2.3.2. A set of samples submitted for approval shall be considered satisfactory from the point of view of the headform test if one of the following two conditions is met :
- 3.2.3.2.1. All the tests give satisfactory results, or
- 3.2.3.2.2. One test having given an unsatisfactory result, a further series of tests carried out on a new set of samples gives satisfactory results.

3.3. Headform test on flat test pieces

3.3.1. Number of test pieces

Six flat test pieces measuring $(1,100 \text{ mm} \times 500 \text{ mm})_{\pm 2}^5$ shall be subjected testing

3.3.2. Test method

3.3.2.1. The method used shall be that described in Annex 3, paragraph 3.3.1.

3.3.2.2. The height of drop shall be $4 \text{ m }_{-0}^{+25} \text{ mm}$.

3.3.3. Interpretation of results

3.3.3.1. This test shall be deemed to have given a satisfactory result if the following conditions are fulfilled :

3.3.3.1.1. the test piece yields and breaks, displaying numerous circular cracks centred approximately on the point of impact;

3.3.3.1.2. tears in the interlayer are allowed provided that the manikin's head does not pass through the test piece.

3.3.3.1.3. no large fragments of glass shall become detached from the interlayer.

3.3.3.2. A set of test pieces submitted for approval shall be considered satisfactory from the point of view of the headform test if one of the following two conditions is met :

3.3.3.2.1. all the tests give satisfactory results, or

3.3.3.2.2. one test having given an unsatisfactory result, a further series of tests carried out on a new set of test pieces gives satisfactory results.

4. MECHANICAL STRENGTH TEST

4.1. Indices of difficulty of the secondary characteristics

No secondary characteristic is involved.

4.2. 2,260 g ball test

4.2.1. Number of test pieces

Six square test pieces of $300 \text{ mm }_{-0}^{+10} \text{ mm}$ side shall be subjected to testing.

4.2.2. Test method

4.2.2.1. The method used shall be that described in Annex 3, paragraph 2.2.

4.2.2.2. The height of drop (from the underface of the ball to the upper face of the test piece) shall be $4 \text{ m }_{-0}^{+25} \text{ mm}$.

>f

4.2.3. Interpretation of results

4.2.3.1. The test shall be deemed to have given a satisfactory result if the ball does not pass through the glazing within five seconds after the moment of impact.

4.2.3.2. A set of test pieces submitted for approval shall be considered satisfactory from the point of view of the 2,260 g ball test if one of the following two conditions is met :

4.2.3.2.1. All the tests give satisfactory results, or

4.2.3.2.2. One test having given an unsatisfactory result, a further series of tests carried out on a new set of test pieces gives satisfactory results.

4.3. 227 g ball test

4.3.1. Indices of difficulty of the secondary characteristics
 No secondary characteristic is involved.

4.3.2. Number of test pieces
 Twenty square test pieces of 300 mm ± 10 mm side shall be subjected to testing.

4.3.3. Test method

4.3.3.1. The method used shall be that described in annex 3, paragraph 2.1..
 Ten specimens shall be tested at a temperature of + 40° \pm 2°C and ten at a temperature of - 20° \pm 2°C.

4.3.3.2. The height of drop for the various thickness categories and the mass of the detached fragments are given in the table below :

Thickness of test piece	+ 40°C		- 20°C	
	Height of fall	Maximum permitted mass of the fragments	Height of fall	Maximum permitted mass of the fragments
mm	m [*] /	g	m [*] /	g
e ≤ 4.5	9	12	8.5	12
4.5 < e ≤ 5.5	10	15	9	15
5.5 < e ≤ 6.5	11	20	9.5	20
e > 6.5	12	25	10	25

^{*}/ A tolerance of +25 -0 mm is allowed in height of fall.

4.3.4. Interpretation of results

4.3.4.1. The test shall be considered to have given a satisfactory result if the following conditions are met :

The ball does not pass through the test piece,
The test piece does not break into several pieces,
If the interlayer is not torn, the weight of fragments detached from the side of the glass opposite to the point of impact must not exceed the appropriate values specified in paragraph 4.3.3.2. above.

4.3.4.2. A set of test pieces submitted for approval shall be considered satisfactory from the point of view of the 227 g ball test if one of the following conditions is met :

4.3.4.2.1. Not less than eight tests at each test temperature give a satisfactory result, or

4.3.4.2.2. More than two tests at each test temperature having given an unsatisfactory result, a further series of tests carried out on a new set of test pieces gives satisfactory results.

5. TEST OF RESISTANCE TO THE ENVIRONMENT

5.1. Test of resistance to abrasion

5.1.1. Indices of difficulty and test method

The requirements of annex 3, paragraph 4, shall apply, the test being continued for 1,000 cycles.

5.1.2. Interpretation of results

The safety-glass pane shall be considered satisfactory with respect to abrasion resistance if the light scatter as a result of abrasion of the test piece does not exceed 2 per cent.

5.2. Test of resistance to high temperature

The requirements of annex 3, paragraph 5, shall apply.

5.3. Resistance-to-radiation test

5.3.1. General requirement

This test shall be performed only if the laboratory deems it useful in the light of the information in its possession concerning the interlayer.

5.3.2. The requirements of annex 3, paragraph 6, shall apply.

5.4. Resistance-to-humidity test

The requirements of annex 3, paragraph 7, shall apply.

6. OPTICAL QUALITIES

The requirements concerning optical qualities set out in annex 3, paragraph 9, shall apply to every type of windscreen.

Annex 7

LAMINATED-GLASS PANES OTHER THAN WINDSCREENS

1. DEFINITION OF TYPE

Laminated-glass panes other than windscreens shall be deemed to belong to different types if they differ in at least one of the following principal or secondary characteristics.

1.1. The principal characteristics are as follows :

1.1.1. The trade name or mark,

1.1.2. The thickness category of the pane in which the nominal thickness 'e' lies, a manufacturing tolerance of $\pm 0.2 n$ mm ('n' being the number of layers of glass in the pane) being allowed :

Category I $e \leq 5.5$ mm
Category II $5.5 \text{ mm} < e \leq 6.5$ mm
Category III $6.5 \text{ mm} < e$

1.1.3. The nominal thickness of the interlayer or interlayers,

1.1.4. The nature and type of the interlayer or interlayers, e.g. PVB or other plastics-material interlayer or interlayers,

1.1.5. Any special treatment which one of the layers of glass may have undergone.

1.2. The secondary characteristics are as follows :

1.2.1. The nature of the material (polished (plate) glass, float glass, sheet glass),

1.2.2. The colouring (total or partial) of the interlayer or interlayers (colourless or tinted),

1.2.3. The colouring of the glass (colourless or tinted).

2. GENERAL

2.1. In the case of laminated-glass panes other than windscreens, the tests shall be conducted on flat test pieces which are either cut from actual glass panes or are specially made. In either case the test pieces shall be in all respects rigorously representative of the glass panes for the production of which approval is sought.

2.2. Before each test the test pieces of laminated glass shall be stored for not less than four hours at a temperature of $23^{\circ}\text{C} \pm 2^{\circ}\text{C}$. The tests shall be performed on the test pieces as soon as the test pieces have been taken out of the receptacle in which they were stored.

2.3. The provisions of this Annex shall be considered to be met if the glazing submitted for approval is of the same composition as a windscreen already approved under the provisions of annex 6 or annex 8 or annex 9.

3. HEADFORM TEST

3.1. Indices of difficulty of the secondary characteristics

No secondary characteristic is involved.

3.2. Number of test pieces

Six flat test pieces measuring (1,100 mm x 500 mm) $\pm \frac{25}{0}$ mm shall be subjected to testing.

3.3. Test method

3.3.1. The method used shall be that described in annex 3, paragraph 3.

3.3.2. The height of drop shall be 1.50 m $\pm \frac{0}{5}$ mm.

3.4. Interpretation of results

3.4.1. This test shall be deemed to have given a satisfactory result if the following conditions are met :

3.4.1.1. The test piece yields and breaks, displaying numerous circular cracks centred approximately on the point of impact,

3.4.1.2. Tears in the interlayer are allowed, but the manikin's head must not pass through,

3.4.1.3. No large fragments of glass shall become detached from the interlayer.

3.4.2. A set of test pieces subjected to approval testing shall be considered satisfactory from the point of view of the headform test if one of the following two conditions is met :

3.4.2.1. All the tests give satisfactory results, or

3.4.2.2. One test having given an unsatisfactory result, a further series of tests carried out on a new set of test pieces gives satisfactory results.

4. MECHANICAL STRENGTH TEST - 227 g BALL TEST

4.1. Indices of difficulty of the secondary characteristics

No secondary characteristic is involved.

4.2. Number of test pieces

Four flat square test pieces of (300 mm x 300 mm) $\pm \frac{10}{0}$ mm side shall be subjected to testing.

4.3. Test method

4.3.1. The method used shall be that described in annex 3, paragraph 2.1..

4.3.2. The height of drop (from the underface of the ball to the upper face of the test piece) shall be as indicated in the following table as a function of nominal thickness :

Nominal thickness	Height of drop
$e \leq 5.5 \text{ mm}$	5 m)
$5.5 \text{ mm} < e \leq 6.5 \text{ mm}$	6 m) +25
$6.5 \text{ mm} < e$	7 m) -0 mm

4.4. Interpretation of results

4.4.1. The test shall be considered to have given a satisfactory result if the following conditions are met :

the ball does not pass through the test piece,
 the test piece does not break into several fragments,
 the total weight of the few fragments which may be produced on the side opposite to the point of impact does not exceed 15 g.

4.4.2. A set of test pieces subjected to approval testing shall be considered satisfactory from the point of view of mechanical strength if one of the following conditions is met :

4.4.2.1. All the tests have given a satisfactory result, or

4.4.2.2. Not more than two tests having given an unsatisfactory result, a further series of tests carried out on a new set of test pieces gives satisfactory results.

5. TEST OF RESISTANCE TO THE ENVIRONMENT

5.1. Test of resistance to abrasion

5.1.1. Indices of difficulty and test method

The requirements of annex 3, paragraph 4, shall apply, the test being continued for 1,000 cycles.

5.1.2. Interpretation of results

The safety-glass pane shall be considered satisfactory from the point of view of abrasion resistance if the light scatter as a result of abrasion of the test piece does not exceed 2 per cent.

5.2. Test of resistance to high temperature

The requirements of annex 3, paragraph 5, shall apply.

5.3. Resistance-to-radiation test

5.3.1. General requirement

This test shall be performed only if the laboratory deems it useful in the light of the information in its possession concerning the interlayer.

5.3.2. The requirements of annex 3, paragraph 6, shall apply.

5.4. Resistance-to-humidity test

The requirements of annex 3, paragraph 7, shall apply.

6. OPTICAL QUALITIES

The provisions concerning the regular light transmittance set out in annex 3, paragraph 9.1., shall apply to glass panes other than windscreens, or parts of glass panes other than windscreens located at places which are essential to the driver's vision.

Annex 8

TREATED LAMINATED-GLASS WINDSCREENS

1. DEFINITION OF TYPE

Treated laminated-glass windscreens shall be deemed to belong to different types if they differ in at least one of the following principal or secondary characteristics.

1.1. The principal characteristics are as follows :

1.1.1. The trade name or mark,

1.1.2. The shape and dimensions
Treated laminated-glass windscreens shall be deemed to belong to one group for the purposes of tests of fragmentation, of mechanical properties and of resistance to the environment.

1.1.3. The number of layers of glass,

1.1.4. The nominal thickness 'e' of the windscreen, a manufacturing tolerance of 0.2 mm ('n' being the number of layers of glass in the windscreen) above and below the nominal value being allowed,

1.1.5. Any special treatment which one or more layers of glass may have undergone,

1.1.6. The nominal thickness of the interlayer or interlayers,

1.1.7. The nature and type of the interlayer or interlayers (e.g. PVB or other plastics-material interlayer or interlayers).

1.2. The secondary characteristics are as follows :

1.2.1. The nature of the material (polished (plate) glass, float glass, sheet glass),

1.2.2. The colouring (total or partial) of the interlayer or interlayers (colourless or tinted),

1.2.3. The colouring of the glass (colourless or tinted),

1.2.4. The incorporation or otherwise of conductors,

1.2.5. The incorporation or otherwise of obscuration bands.

2. GENERAL

2.1. In the case of treated laminated-glass windscreens, tests other than the headform test on a complete windscreen and tests of optical qualities shall be conducted on samples and/or flat test pieces which are specially made for the purpose. However, the test pieces shall be in all respects rigorously representative of the serially-produced windscreens for which approval is sought.

2.2. Before each test, the test pieces or samples shall be stored for not less than four hours at a temperature of $23^{\circ}\text{C} \pm 2^{\circ}\text{C}$. The tests shall take place as soon as possible after the test pieces or samples have been taken out of the receptacle in which they were stored.

3. TESTS PRESCRIBED

Treated laminated-glass windscreens shall be subjected to :

3.1. The tests prescribed in annex 6 for ordinary laminated-glass windscreens,

3.2. The fragmentation test described in paragraph 4 below.

4. FRAGMENTATION TEST

4.1. Indices of difficulty of the secondary characteristics

MATERIAL	INDEX OF DIFFICULTY
Plate glass	2
Float glass	1
Sheet glass	1

4.2. Number of test pieces or samples

One test piece measuring $(1,100 \times 500 \text{ mm}) \pm 5 \text{ mm}$ or one sample for each point of impact shall be subjected to testing.

4.3. Test method

The method used shall be that described in annex 3, paragraph 1.

4.4. Impact point or points

The glass pane shall be struck on each of the outer treated sheets in the centre of the test piece or sample.

4.5. Interpretation of results

4.5.1. For each point of impact the fragmentation test shall be considered to have given a satisfactory result if the total surface area of fragments having a surface area of more than 2 cm^2 comprised in a rectangle as defined in annex 4, paragraph 2.3.2., represents not less than 15 per cent of the surface of that rectangle.

4.5.1.1. In the case of a sample :

4.5.1.1.1. For vehicles of category M_1 , the centre of the rectangle shall be situated within a circle having a radius of 10 cm centred on the projection of the middle of segment $V_1 V_2$.

- 4.5.1.1.2. For vehicles of categories M and N other than M₁, the centre of the rectangle shall be situated within a circle having a radius of 10 cm centred on the projection of point O.
- 4.5.1.1.3. For agricultural and forestry tractors and for construction-site vehicles, the position of the visibility zone shall be indicated in the test report.
- 4.5.1.1.4. The height of the above rectangle may be reduced to 15 cm for windscreens which are less than 44 cm high or whose angle of installation is less than 15° from the vertical; the percentage of visibility shall at least be equal to 10 per cent of the area of the corresponding rectangle.
- 4.5.1.2. In the case of a test piece, the centre of the rectangle shall be situated on the greater axis of the test piece at 450 mm from one of its edges.
- 4.5.2. The test piece(s) or sample(s) submitted for approval shall be considered satisfactory from the point of view of fragmentation if either of the following conditions is met :
- 4.5.2.1. The test gives a satisfactory result for each point of impact, or
- 4.5.2.2. The test having been repeated on a new set of four test pieces for each point of impact for which it had originally given an unsatisfactory result, the four new tests, performed at the same impact points all give a satisfactory result.
-

Annex 9

SAFETY-GLASS PANES FACED WITH PLASTICS MATERIAL
(on the inside)

1. DEFINITION OF TYPE

Safety glazing materials, as defined in annex 4 to 8, if coated on the inner face with a layer of plastics material, shall conform not only to the requirements of the appropriate annexes but also to the following requirements.

2. TEST OF RESISTANCE TO ABRASION

2.1. Indices of difficulty and test method

The plastics coating shall be subjected to a test for 100 cycles in accordance with the requirements specified in annex 3, paragraph 4.

2.2. Interpretation of results

The plastics coating shall be considered satisfactory with respect to abrasion resistance if the light scatter as a result of abrasion of the test piece does not exceed 4 per cent.

3. RESISTANCE-TO-HUMIDITY TEST

3.1. In the case of plastics-coated toughened safety glazing material a resistance-to-humidity test shall be performed.

3.2. The requirements of annex 3, paragraph 7, shall apply.

4. TEST OF RESISTANCE TO TEMPERATURE CHANGES

The requirements of annex 3, paragraph 8, shall apply.

5. FIRE-RESISTANCE TEST

The requirements of annex 3, paragraph 10, shall apply.

6. TEST OF RESISTANCE TO CHEMICALS

The requirements of annex 3, paragraph 11, shall apply.

Annex 10

GLASS-PLASTICS WINDSCREENS

1. DEFINITION OF TYPE

Glass-plastics windscreens shall be considered to belong to different types if they differ in at least one of the following principal or secondary characteristics.

1.1. The principal characteristics are as follows :

- 1.1.1. The trade name or mark,
- 1.1.2. The shape and dimensions.
Glass-plastics windscreens shall be deemed to belong to a group for the purposes of tests of mechanical strength, resistance to the environment, resistance to temperature changes and resistance to chemical agents,
- 1.1.3. The number of plastics layers,
- 1.1.4. The nominal thickness 'e' of the windscreen, a manufacturing tolerance of ± 0.2 mm being allowed,
- 1.1.5. The nominal thickness of the layer of glass,
- 1.1.6. The nominal thickness of the layer(s) of plastics acting as interlayer(s),
- 1.1.7. The nature and type of the layer(s) of plastics acting as interlayer(s) (e.g. PVB or other material) and of the plastics layer situated on the inner face,
- 1.1.8. Any special treatment the glass pane may have undergone.

1.2. The secondary characteristics are as follows :

- 1.2.1. The nature of the material (plate glass, float glass, sheet glass),
- 1.2.2. The colouring (total or partial) of any layer(s) of plastics (colourless or tinted),
- 1.2.3. The colouring of the glass (colourless or tinted),
- 1.2.4. The incorporation or otherwise of conductors,
- 1.2.5. The incorporation or otherwise of obscuration bands.

2. GENERAL

- 2.1. In the case of glass-plastics windscreens, tests other than headform tests (paragraph 3.2.) and tests of optical qualities shall be conducted on flat test pieces which are either cut from actual windscreens or are specially made for the purpose. In either case the test pieces shall in all respects be rigorously representative of the serially-produced windscreens for which approval is sought.

2.2. Before each test, the test pieces shall be stored for not less than four hours at a temperature of $23^{\circ}\text{C} \pm 2^{\circ}\text{C}$. The tests shall take place as soon as possible after the test pieces have been taken out of the receptacle in which they were stored.

3. HEADFORM TEST

3.1. Indices of difficulty of the secondary characteristics

No secondary characteristic is involved.

3.2. Headform test on a complete windscreen

3.2.1. Number of samples

Four samples from the series having the smallest developed area and four samples from the series having the largest developed area, selected in accordance with the provisions of annex 13, shall be tested.

3.2.2. Test method

3.2.2.1. The method used shall be that described in annex 3, paragraph 5.3.2..

3.2.2.2. The height of drop shall be $1.50 \text{ m} \pm \frac{0}{5} \text{ mm}$.

3.2.3. Interpretation of results

3.2.3.1. This test shall be considered to have given a satisfactory result if the following conditions are met.

3.2.3.1.1. The layer of glass breaks, displaying numerous circular cracks centred approximately on the point of impact, the cracks nearest to the point of impact being not more than 80 mm from it;

3.2.3.1.2. The layer of glass remains adhering to the plastics material interlayer. One or more partial separations from the interlayer not more than 4 mm in breadth may be allowed on either side of the crack outside a circle 60 mm in diameter centred on the point of impact;

3.2.3.1.3. A tear in the interlayer of a length up to 35 mm is allowed on the impact side.

3.2.3.2. A set of test pieces submitted for approval shall be considered satisfactory with respect to the headform test if one of the following two conditions is met :

3.2.3.2.1. All the tests give satisfactory results, or

3.2.3.2.2. One test having given an unsatisfactory result, a further series of tests carried out on a new set of test pieces gives satisfactory results.

3.3. Headform test on flat test pieces

3.3.1. Number of test pieces

Six flat test pieces measuring $(1,100 \text{ mm} \times 500 \text{ mm}) \pm \frac{5}{2} \text{ mm}$ shall be subjected to testing.

3.3.2. Test method

3.3.2.1. The method used shall be that described in annex 3, paragraph 3.3.1..

3.3.2.2. The height of drop shall be $4 \text{ m } \begin{matrix} +25 \\ -0 \end{matrix} \text{ mm}$.

3.3.3. Interpretation of results

3.3.3.1. This test shall be considered to have given a satisfactory result if the following conditions are met :

3.3.3.1.1. The layer of glass yields and breaks, displaying numerous circular cracks centred approximately on the point of impact;

3.3.3.1.2. Tears in the interlayer are allowed, but the manikin's head must not pass through;

3.3.3.1.3. No large fragment of glass shall become detached from the interlayer.

3.3.3.2. A set of test pieces submitted for approval shall be considered satisfactory with respect to the headform test if one of the following conditions is met :

3.3.3.2.1. All the tests give satisfactory results, or

3.3.3.2.2. One test having given an unsatisfactory result, a further series of tests carried out on a new set of test pieces gives satisfactory results.

4. MECHANICAL STRENGTH TEST

4.1. Indices of difficulty, test method and interpretation of results

The requirements of annex 6, paragraph 4, shall apply.

4.2. However the third requirement set out in paragraph 4.3.4.1. of annex 6 is not relevant.

5. TEST OF RESISTANCE TO THE ENVIRONMENT

5.1. Test of resistance to abrasion

5.1.1. Test of resistance to abrasion on the outer face

5.1.1.1. The requirements of annex 6, paragraph 5.1., shall apply.

5.1.2. Test of resistance to abrasion on the inner face

5.1.2.1. The requirements of annex 9, paragraph 2, shall apply.

5.2. Test of resistance to high temperature

The requirements of annex 3, paragraph 5, shall apply.

5.3. Resistance to radiation test

The requirements of annex 3, paragraph 6, shall apply.

5.4. Resistance-to-humidity test

The requirements of annex 3, paragraph 7, shall apply.

5.5. Test of resistance to temperature changes

The requirements of annex 3, paragraph 8, shall apply.

6. OPTICAL QUALITIES

The requirements concerning optical qualities set out in annex 3, paragraph 9, shall apply to each type of windscreen.

7. FIRE-RESISTANCE TEST

The requirements of annex 3, paragraph 10, shall apply.

8. TEST OF RESISTANCE TO CHEMICALS

The requirements of annex 3, paragraph 11, shall apply.

Annex 11

GLASS-PLASTICS PANES OTHER THAN WINDSCREENS

1. DEFINITION OF TYPE

Glass-plastics panes other than windscreens shall be considered to belong to different types if they differ in at least one of the following principal or secondary characteristics.

1.1. The principal characteristics are as follows :

1.1.1. The trade name or mark,

1.1.2. The thickness category applicable to the nominal thickness 'e', a manufacturing tolerance of ± 0.2 mm being allowed :

Category I	$e \leq 3.5$ mm
Category II	$3.5 \text{ mm} < e \leq 4.5$ mm
Category III	$4.5 \text{ mm} < e$

1.1.3. The nominal thickness of the layer(s) of plastics material acting as interlayer(s),

1.1.4. The nominal thickness of the glass pane,

1.1.5. The type of the layer(s) of plastics material acting as interlayer(s) (e.g. PVB or other material) and of the plastics layer on the inner face,

1.1.6. Any special treatment which the layer of glass may have undergone.

1.2. The secondary characteristics are as follows :

1.2.1. The nature of the material (plate glass, float glass, sheet glass),

1.2.2. The colouring (total or partial) of any layer(s) of plastics (colourless or tinted),

1.2.3. The colouring of the glass (colourless or tinted).

2. GENERAL

2.1. In the case of glass-plastics panes other than windscreens the tests shall be conducted on flat test pieces which are either cut from normal glass panes or are specially made. In either case the test pieces shall be in all respects rigorously representative of the glass panes for the production of which approval is sought.

2.2. Before each test, the test pieces of glass-plastics panes shall be stored for not less than four hours at a temperature of $23^{\circ}\text{C} \pm 2^{\circ}\text{C}$. The tests shall take place as soon as possible after the test pieces have been taken out of the receptacle in which they were stored.

2.1. The provisions of this Annex shall be considered to be met if the glass pane submitted for approval has the same composition as that of a windscreen already approved under the provisions of annex 10.

3. HEADFORM TEST

3.1. Indices of difficulty of the secondary characteristics

No secondary characteristic is involved.

3.2. Number of test pieces

Six flat test pieces measuring $(1,100 \text{ mm} \times 500 \text{ mm}) \pm \frac{5}{2} \text{ mm}$ shall be subjected to testing.

3.3. Test method

3.3.1. The method used shall be that described in annex 3, paragraph 3.

3.3.2. The height of drop shall be $1.50 \text{ m} \pm \frac{0}{5} \text{ mm}$.

3.4. Interpretation of results

3.4.1. This test shall be considered to have given a satisfactory result if the following conditions are met :

3.4.1.1. The layer of glass breaks, displaying numerous cracks;

3.4.1.2. Tears in the interlayer are allowed, provided that the manikin's head does not pass through the test piece;

3.4.1.3. No large fragment of glass shall become detached from the interlayer.

3.4.2. A set of test pieces submitted for approval shall be considered satisfactory with respect to the headform test if one of the following conditions is met :

3.4.2.1. All the tests give satisfactory results, or

3.4.2.2. One test having given an unsatisfactory result, a further series of tests carried out on a new set of test pieces gives satisfactory results.

4. MECHANICAL STRENGTH TEST - 227 g BALL TEST

4.1. The provisions of annex 7, paragraph 4, shall apply, with the exception of the table in paragraph 4.3.2., to be replaced by :

Nominal thickness	Height of drop
$e \leq 3.5 \text{ mm}$	5 m)
$3.5 \text{ mm} < e \leq 4.5 \text{ mm}$	6 m) +25
$e > 4.5 \text{ mm}$	7 m) -0 mm

4.2. However the provision in annex 7, paragraph 4.4.1.2., is not relevant.

5. TEST OF RESISTANCE TO THE ENVIRONMENT

5.1. Test of resistance to abrasion

5.1.1. Test of resistance to abrasion on the outer face
The requirements of annex 7, paragraph 5.1., shall apply.

5.1.2. Test of resistance to abrasion on the inner face
The requirements of annex 9, paragraph 2.1., shall apply.

5.2. Test of resistance to high temperature

The requirements of annex 3, paragraph 5, shall apply.

5.3. Resistance-to-radiation test

The requirements of annex 3, paragraph 6, shall apply.

5.4. Resistance-to-humidity test

The requirements of annex 3, paragraph 7, shall apply.

5.5. Test of resistance to temperature changes

The requirements of annex 3, paragraph 8, shall apply.

6. OPTICAL QUALITIES

The provisions concerning the regular light transmittance set out in annex 3, paragraph 9.1., shall apply to glass panes or parts of glass panes other than windscreens located at places which are essential to the driver's vision.

7. FIRE-RESISTANCE TEST

The requirements of annex 3, paragraph 10, shall apply.

8. TEST OF RESISTANCE TO CHEMICALS

The requirements of annex 3, paragraph 11., shall apply.

Annex 12

DOUBLE-GLAZED UNITS

1. DEFINITION OF TYPE

Double-glazed units shall be considered to belong to different types if they differ in at least one of the following principal or secondary characteristics.

1.1. The principal characteristics are as follows :

- 1.1.1. The trade name or mark,
- 1.1.2. The composition of the double-glazed unit (symmetrical, asymmetrical),
- 1.1.3. The type of each component glass pane as defined in paragraph 1 of annexes 5, 7 or 11 to this Regulation,
- 1.1.4. The nominal width of the gap between the two glass panes,
- 1.1.5. The type of sealing (organic, or glass to glass/glass to metal).

1.2. The secondary characteristics are :

- 1.2.1. The secondary characteristics of each component glass pane, as defined in paragraph 1.2. of annexes 5, 7 or 11 to this Regulation.

2. GENERAL

- 2.1. Each component glass pane forming the double-glazed unit shall either be type-approved or subjected to the requirements set out in the relevant annex to this Regulation (Annexes 5, 7 or 11).
- 2.2. Tests carried out on double-glazed units having a nominal width of gap 'e' shall be considered to be applicable to all double-glazed units having the same characteristics and a nominal width of gap $e \pm 3$ mm. However, the applicant for approval may submit for approval tests the sample having the smallest gap and the sample having the largest gap.
- 2.3. In the case of double-glazed units having at least one laminated glass pane or one glass-plastics pane, the test pieces shall be stored for at least four hours prior to the test at a temperature of $23^{\circ}\text{C} \pm 2^{\circ}\text{C}$. The tests shall take place immediately after the test pieces are taken out of the receptacle in which they were stored.

3. HEADFORM TEST

3.1. Index of difficulty of the secondary characteristics

No secondary characteristic is involved.

3.2. Number of test pieces

Six test pieces (1,100 mm x 500 mm) $\pm \frac{5}{2}$ mm shall be subjected to testing for each category of thickness of the component glass panes and each width of gap as defined in paragraph 1.1.4. above.

3.3. Test method

3.3.1. The method used shall be that described in annex 3, paragraph 3.

3.3.2. The height of drop shall be $1.50 \pm \frac{0}{5}$ mm.

3.3.3. In the case of an asymmetrical double-glazed unit, three tests shall be carried out on one side and three tests on the other side.

3.4. Interpretation of results

3.4.1. Double glazing consisting of two uniformly-toughened glass panes :

The test shall be considered to have given a satisfactory result if both components break;

3.4.2. Double glazing consisting of laminated glass panes and/or glass-plastics panes other than windscreens :

The test shall be considered to have given a satisfactory result if the following conditions are met :

3.4.2.1. The two components of the test piece yield and break, displaying numerous circular cracks centred approximately on the point of impact;

3.4.2.2. Tears in the interlayer(s) are allowed provided that the manikin's head does not pass through the test piece;

3.4.2.3. No large fragment of glass becomes detached from the interlayer.

3.4.3. Double glazing consisting of a uniformly-toughened glass pane and of a laminated glass pane or glass-plastics pane other than windscreens :

3.4.3.1. The toughened-glass pane breaks;

3.4.3.2. The laminated glass pane or glass-plastics pane yields and breaks, displaying numerous circular cracks centred approximately on the point of impact;

3.4.3.3. Tears in the interlayer(s) are allowed provided that the manikin's head does not pass through the test piece;

3.4.3.4. No large fragment of glass becomes detached from the interlayer.

3.4.4. A set of test pieces submitted for approval shall be considered satisfactory with respect to behaviour under head impact if one of the following two conditions is met :

3.4.4.1. All the tests give satisfactory results,

3.4.4.2. One test having given an unsatisfactory result, a further series of tests carried out on a new set of test pieces gives satisfactory results.

4. OPTICAL QUALITIES

The provisions concerning the regular light transmittance set out in annex 3, paragraph 9.1., shall apply to double glazed units or parts of double-glazed units located at places which are essential to the driver's vision.

Annex 13

GROUPING OF WINDSCREENS FOR APPROVAL TESTING

1. THE WINDSCREEN'S FEATURES TAKEN INTO ACCOUNT ARE:
 - 1.1. The developed area,
 - 1.2. The height of segment,
 - 1.3. The curvature.
2. A GROUP IS MADE UP OF A THICKNESS CLASS
3. CLASSIFICATION IS PERFORMED IN ASCENDING ORDER OF DEVELOPED AREA
The five largest and the five smallest developed areas shall be selected, and shall be numbered as follows :

1 for the largest	1 for the smallest
2 for the next largest after 1	2 for the next smallest after 1
3 for the next largest after 2	3 for the next smallest after 2
4 for the next largest after 3	4 for the next smallest after 3
5 for the next largest after 4	5 for the next smallest after 4.
4. WITHIN EACH OF THE TWO SERIES DEFINED UNDER PARAGRAPH 3 ABOVE, THE HEIGHTS OF SEGMENT SHALL BE INDICATED AS FOLLOWS :
 - 1 for the greatest height of segment,
 - 2 for the next greatest,
 - 3 for the next greatest,
 - etc...
5. WITHIN EACH OF THE TWO SERIES DEFINED UNDER PARAGRAPH 3 ABOVE, THE CURVATURES SHALL BE INDICATED AS FOLLOWS :
 - 1 for the smallest curvature,
 - 2 for the next smallest,
 - 3 for the next smallest,
 - etc...
6. THE NUMBERS ASSIGNED TO EACH WINDSCREEN IN THE TWO SERIES DEFINED UNDER PARAGRAPH 3 ABOVE SHALL BE ADDED TOGETHER.
 - 6.1. The windscreen among those having the five largest areas which has the smallest total, and the windscreen among those having the five smallest areas which has the smallest total, shall be subjected to complete tests as defined in one of annexes 4, 6, 8, 9 and 10.
 - 6.2. The other windscreens of the same series shall be subjected to the tests of optical qualities described in annex 3, paragraph 9.

7. A few windscreens having significantly different parameters of shape and/or curvature from the extremes of the selected groups may also be tested if the technical service conducting the tests considers that the parameters in question are likely to have appreciably adverse effects.
8. The limits of the group are determined by developed area of windscreen. Where a windscreen submitted for type-approval has a developed area outside the approved limits and/or has a significantly greater height of segment or a significantly smaller curvature, it shall be considered to be of a new type and shall be subjected to additional tests if the technical service deems such tests technically necessary, having regard to the information already in its possession concerning the product and the material used.
9. Should any other windscreen model subsequently be manufactured by the holder of an approval in a thickness class already approved :
 - 9.1. It shall be ascertained whether that model can be included among the five largest or the five smallest selected for approval of the group in question;
 - 9.2. Numbering by the procedures defined in paragraphs 3, 4 and 5 above shall be performed again.
 - 9.3. If the sum of the numbers assigned to the windscreen newly incorporated among the five largest or the five smallest windscreens
 - 9.3.1. Is found to be the smallest, the following tests shall be carried out :
 - 9.3.1.1. For toughened-glass windscreens :
 - 9.3.1.1.1. Fragmentation,
 - 9.3.1.1.2. Headform test,
 - 9.3.1.1.3. Optical distortion,
 - 9.3.1.1.4. Separation of secondary image,
 - 9.3.1.1.5. Light transmission.
 - 9.3.1.2. For ordinary laminated-glass or glass-plastics windscreens :
 - 9.3.1.2.1. Headform test,
 - 9.3.1.2.2. Optical distortion,
 - 9.3.1.2.3. Separation of secondary image,
 - 9.3.1.2.4. Light transmission.
 - 9.3.1.3. For treated laminated-glass windscreens, the tests prescribed in paragraphs 9.3.1.1.1., 9.3.1.1.2. and 9.3.1.2.
 - 9.3.1.4. For windscreens faced with plastics material, the tests prescribed in paragraph 9.3.1.1. or 9.3.1.2., as the case may be.
 - 9.3.2. If not, only the tests prescribed for checking optical qualities as described in Annex 3, paragraph 9, shall be carried out.

Annex 14

MEASUREMENT OF THE HEIGHT OF SEGMENT AND
POSITION OF THE POINTS OF IMPACT

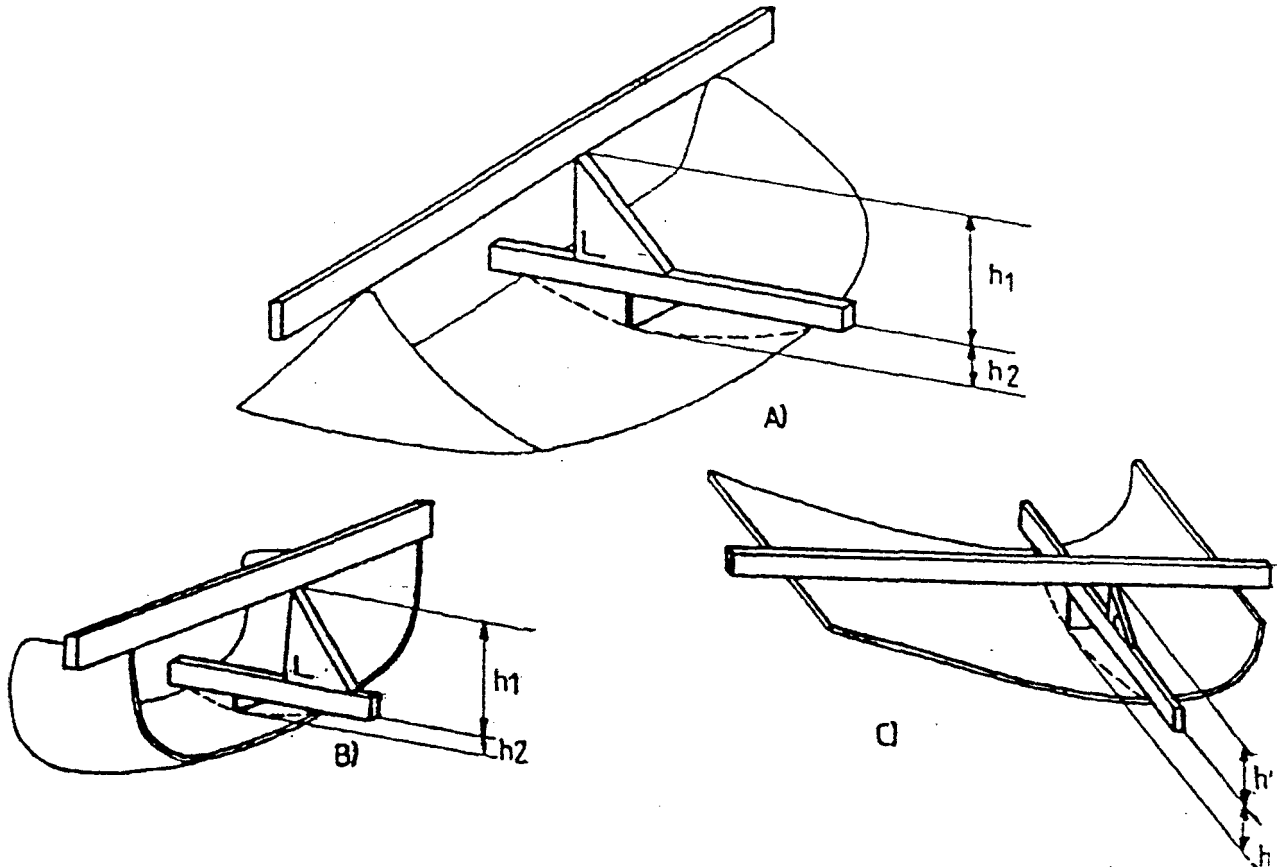

Figure 1 : Determination of the height of segment 'h'

In the case of a safety-glass pane having a simple curvature, the height of segment will be equal to : h_1 maximum.

In the case of a safety-glass pane having a double curvature, the height of segment will be equal to : h_1 maximum + h_2 maximum.

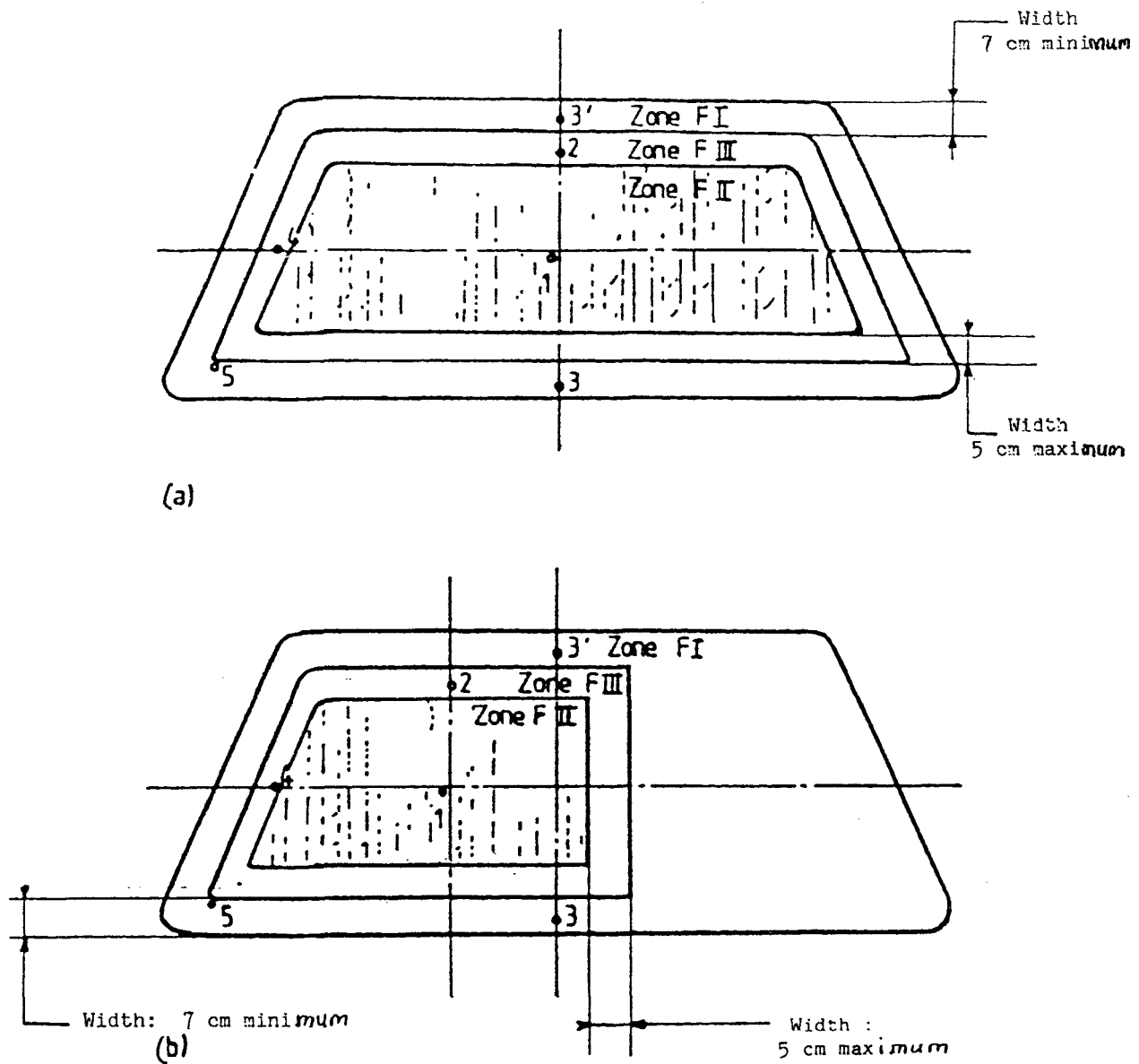
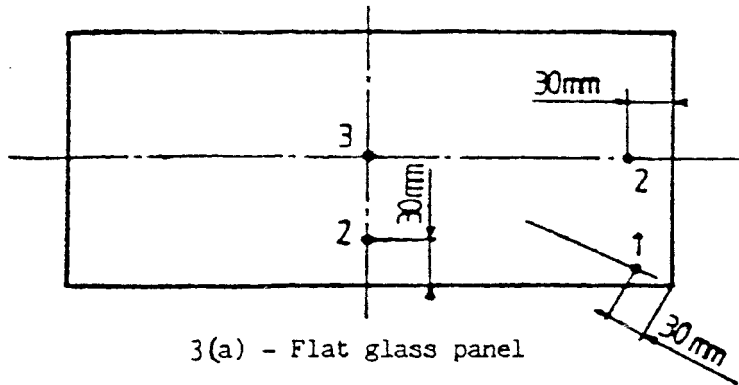
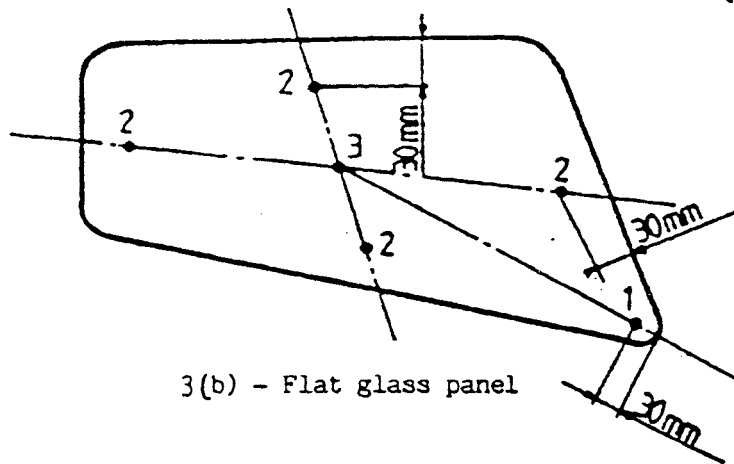

Figure 2 : Prescribed points of impact for windscreens



3(a) - Flat glass panel



3(b) - Flat glass panel

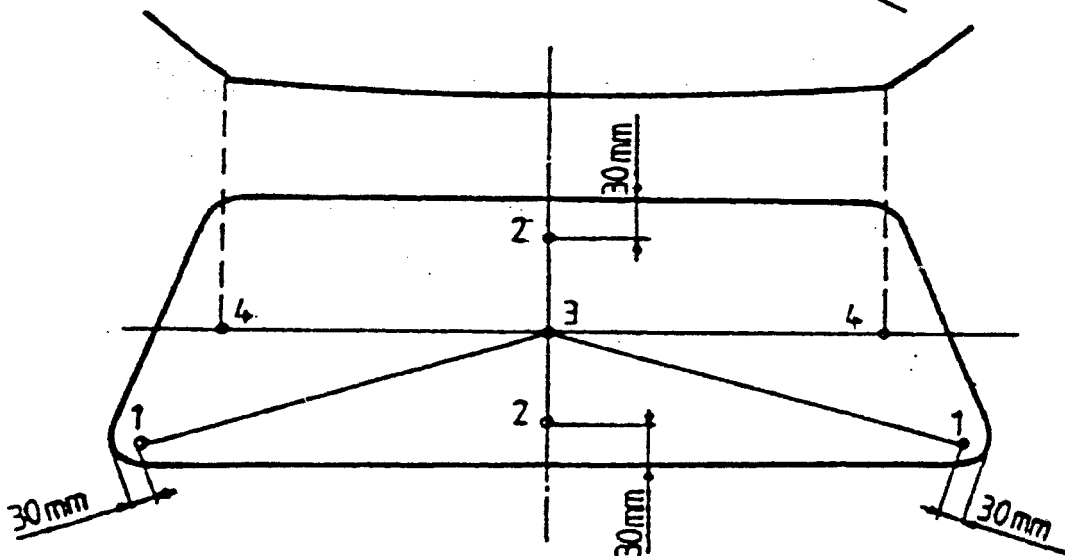

3(c) - Curved glass panel

Figures 3(a), 3(b) and 3(c) : Prescribed points of impact for uniformly-toughened glass panes.

The points '2' shown in figures 3(a), 3(b) and 3(c) are examples of the sites for point '2' prescribed in annex 5, paragraph 2.5..

Annex 15

PROCEDURE FOR DETERMINING TEST AREAS ON WINDSCREENS OF
 M₁ CATEGORY VEHICLES IN RELATION TO THE 'V' POINTS

1. POSITION OF THE 'V' POINTS
 - 1.1. The position of the 'V' points in relation to the 'R' point (see annex 16 to this Regulation), as indicated by the X Y and Z co-ordinates in the three-dimensional reference system, are shown in tables 1 and 2.
 - 1.2. Table 1 gives the basic co-ordinates for a design seat-back angle of 25°. The positive direction of the co-ordinates is shown in this annex, figure 3.

Table 1

'V' Point	X	Y	Z
V ₁	68 mm	- 5 mm	665 mm
V ₂	68 mm	- 5 mm	589 mm

- 1.3. Correction for design seat-back angles other than 25°
 - 1.3.1. Table 2 shows the further corrections to be made to the X and Z co-ordinates of each 'V' point when the design seat-back angle is not 25°. The positive direction of the co-ordinates is shown in this annex, figure 3.

Table 2-

Seat-back angle (in °)	Horizontal co-ordinates X	Vertical co-ordinates Z	Seat-back angle (in °)	Horizontal co-ordinates X	Vertical co-ordinates Z
5	- 186 mm	28 mm	23	- 17 mm	5 mm
6	- 176 mm	27 mm	24	- 9 mm	2 mm
7	- 167 mm	27 mm	25	0 mm	0 mm
8	- 157 mm	26 mm	26	9 mm	- 3 mm
9	- 147 mm	26 mm	27	17 mm	- 5 mm
10	- 137 mm	25 mm	28	26 mm	- 8 mm
11	- 128 mm	24 mm	29	34 mm	- 11 mm
12	- 118 mm	23 mm	30	43 mm	- 14 mm
13	- 109 mm	22 mm	31	51 mm	- 17 mm
14	- 99 mm	21 mm	32	59 mm	- 21 mm
15	- 90 mm	20 mm	33	67 mm	- 24 mm
16	- 81 mm	18 mm	34	76 mm	- 28 mm
17	- 71 mm	17 mm	35	84 mm	- 31 mm
18	- 62 mm	15 mm	36	92 mm	- 35 mm
19	- 53 mm	13 mm	37	100 mm	- 39 mm
20	- 44 mm	11 mm	38	107 mm	- 43 mm
21	- 35 mm	9 mm	39	115 mm	- 47 mm
22	- 26 mm	7 mm	40	123 mm	- 52 mm

2. TEST AREAS

2.1. Two test areas shall be determined from the 'V' points.

2.2. Test area A is the area on the apparent outer surface of the windscreen bounded by the following four planes extending forward from the 'V' points (see figure 1) :

- a vertical plane passing through V_1 and V_2 and inclined at 13° to the left of the X axis in the case of left-hand drive vehicles and to the right of the X axis in the case of right-hand drive vehicles;
- a plane parallel to the Y axis passing through V_1 and inclined upwards at 3° from the X axis;
- a plane parallel to the Y axis passing through V_2 and inclined downwards at 1° from the X axis;
- a vertical plane passing through V_1 and V_2 and inclined at 20° to the right of the X axis in the case of left-hand drive vehicles and to the left of the X axis in the case of right-hand drive vehicles.

2.3. Test area B is the area of the outer surface of the windscreen which is more than 25 mm from the outer edge of the transparent area and is bounded by the intersection of the following four planes with the outer surface of the windscreen (see figure 2) :

- a plane inclined upward from the X axis at 7° , passing through V_1 and parallel to the Y axis;
- a plane inclined downward from the X axis at 5° , passing through V_2 and parallel to the Y axis;
- a vertical plane passing through V_1 and V_2 and forming an angle of 17° to the left of the X axis in the case of left-hand drive vehicles and to the right of the X axis in the case of right-hand drive vehicles;
- a plane symmetrical with respect to the former plane in relation to the longitudinal median plane of the vehicle.

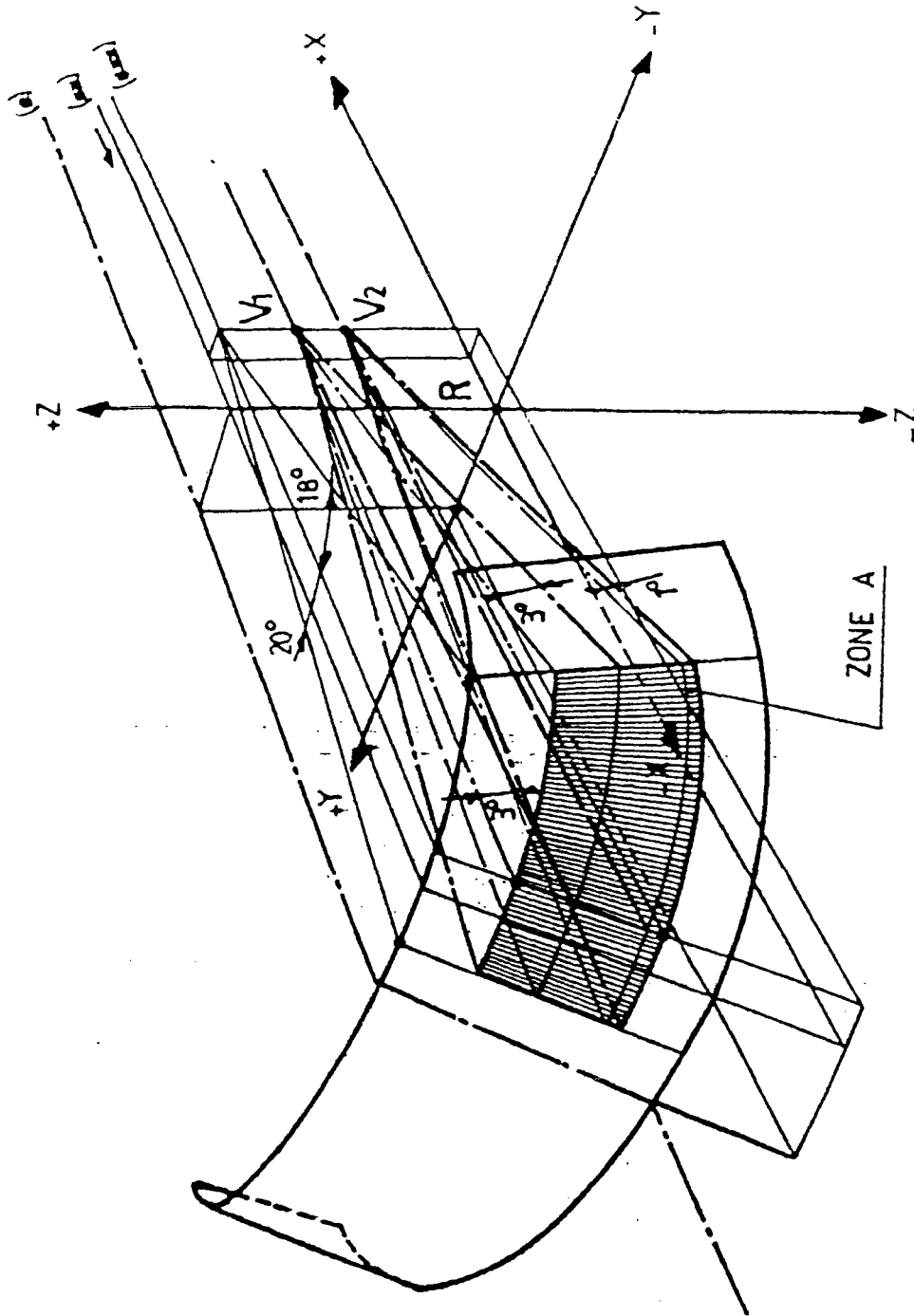

- (*) Trace of longitudinal plane of symmetry of the vehicle
- (**) Trace of vertical plane passing through 'R'
- (***) Trace of vertical plane passing through V_1 and V_2

Figure 1 : TEST AREA 'A' (example of a left-hand drive vehicle)

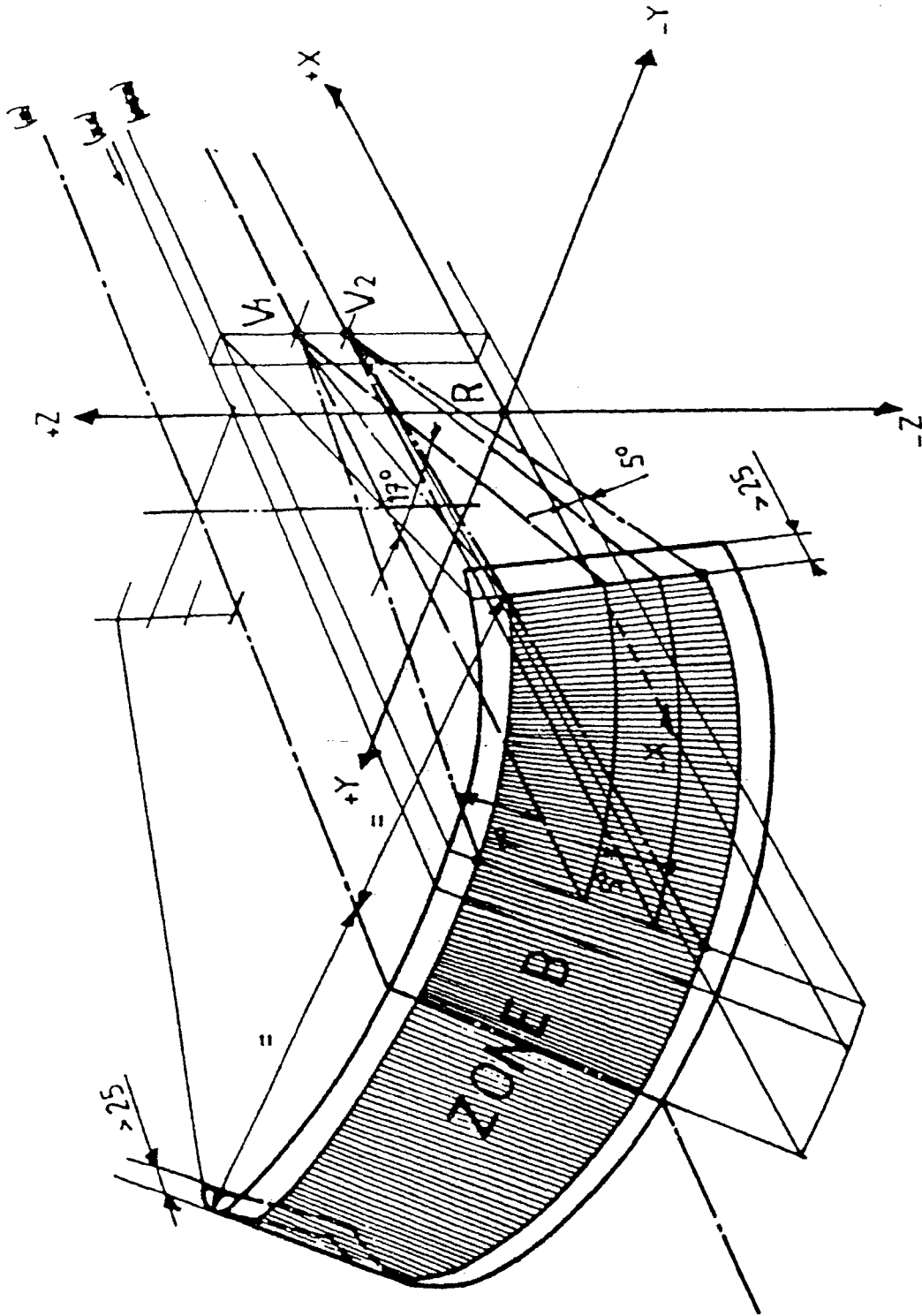

- (*) Trace of longitudinal plane of symmetry of the vehicle
- (**) Trace of longitudinal plane passing through 'R'
- (***) Trace of longitudinal plane passing through V_1 and V_2

Figure 2 : TEST AREA 'B' (example of a left-hand drive vehicle)

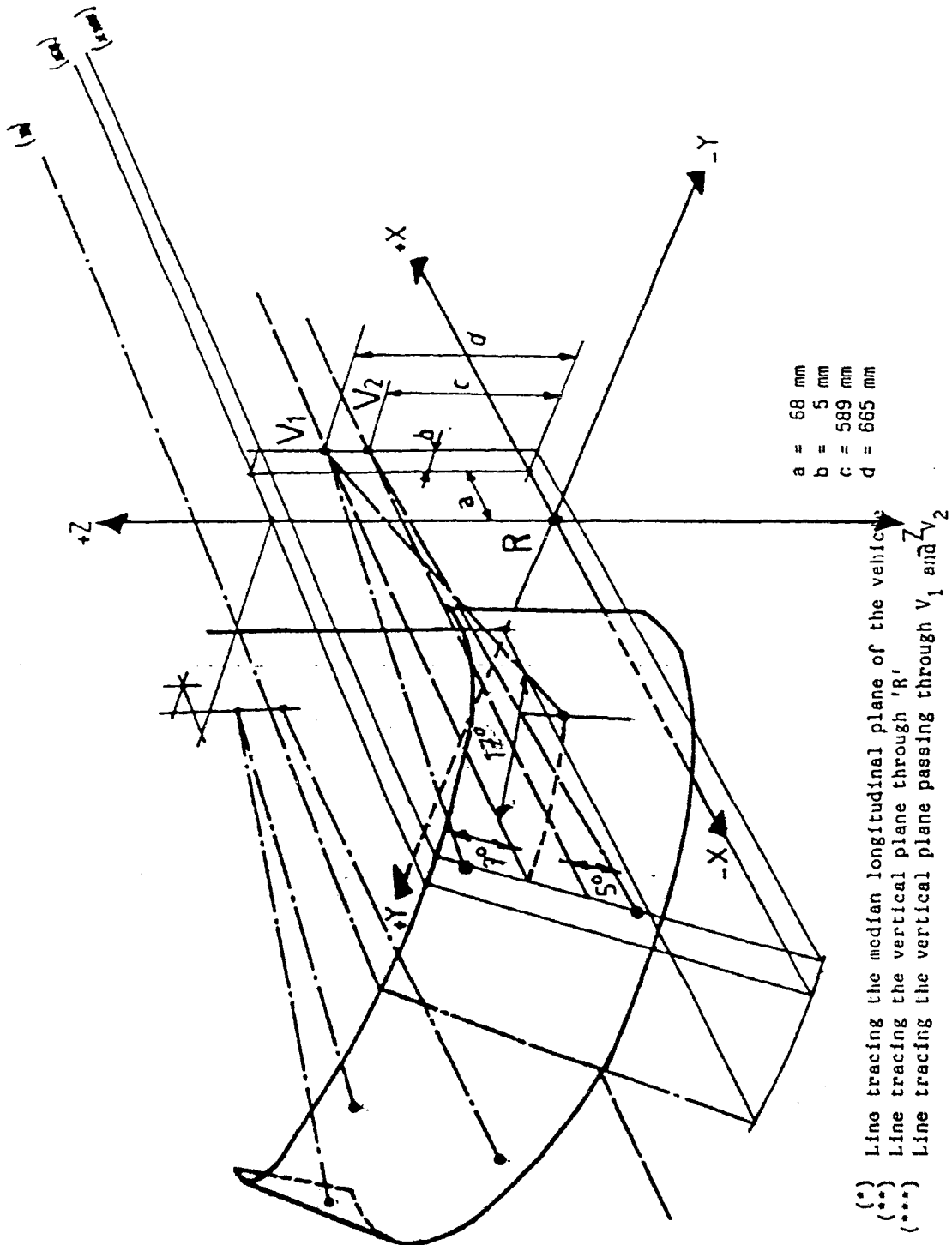

Figure 3 : DETERMINATION OF V POINTS FOR A SEAT-BACK ANGLE OF 25°
 (example of a left-hand drive vehicle)

Annex 16

PROCEDURE FOR DETERMINING THE 'H' POINT AND
THE ACTUAL TORSO ANGLE FOR SEATING POSITIONS IN
MOTOR VEHICLES

1. PURPOSE

The procedure described in this Annex is used to establish the 'H' point location and the actual torso angle for one or several seating positions in a motor vehicle and to verify the relationship of measured data to design specification given by the vehicle manufacturer. ✓

2. DEFINITIONS

For the purposes of this annex.

- 2.1. "Reference data" means one or several of the following characteristics of a seating position :
- 2.1.1. the 'H' point and the 'R' point and their relationship;
- 2.1.2. the actual torso angle and the design torso angle and their relationship.
- 2.2. "Three-dimensional H-point machine" (3 DH machine) means the device used for the determination of H points and actual torso angles.
This device is described in appendix 1 to this annex.
- 2.3. "H point" means the pivot centre of the torso and thigh of the 3 DH machine installed in the vehicle seat in accordance with the procedure described in paragraph 3 below. The H point is located in the centre of the centre line of the device which is between the H point sight buttons on either side of the 3 DH machine. The H point corresponds theoretically to the R point (for tolerances, see paragraph 3.2.2. below). Once determined in accordance with the procedure described in paragraph 4, the H point is considered as fixed in relation to the seat-cushion structure and as moving with it when the seat is adjusted.
- 2.4. "R point" or "seating reference point" means a design point defined by the vehicle manufacturer for each seating position and established with respect to the three-dimensional reference system.
- 2.5. "Torso line" means the centre line of the probe of the 3 DH machine with the probe in the fully rearward position.

✓ In any seating position other than front seats where the H point cannot be determined using the three-dimensional machine or other procedures, the R point indicated by the vehicle manufacturer may be taken as a reference at the discretion of the competent authority.

- 2.6. "Actual torso angle" means the angle measured between a vertical line through the H point and the torso line using the back angle quadrant on the 3 DH machine. The actual torso angle corresponds theoretically to the design torso angle (for tolerances, see paragraph 3.2.2. below).
- 2.7. "Design torso angle" means the angle measured between a vertical line through the R point and the torso line in a position corresponding to the design position of the seat-back specified by the vehicle manufacturer.
- 2.8. "Centre plane of occupant" (CPO) means the median plane of the 3 DH machine positioned in each designated seating position; it is represented by the co-ordinate of the H point on the Y axis. For individual seats, the centre plane of the seat coincides with the centre plane of the occupant. For other seats, the centre plane of the occupant is specified by the manufacturer.
- 2.9. "Three-dimensional reference system" means a system as described in appendix 2 to this annex.
- 2.10. "Fiducial marks" are physical points (holes, surfaces, marks or indentations) on the vehicle body as defined by the manufacturer.
- 2.11. "Vehicle measuring attitude" means the position of the vehicle as defined by the co-ordinates of fiducial marks in the three-dimensional reference system.

3. REQUIREMENTS

3.1. Data presentation

For each seating position where reference data are required in order to demonstrate compliance with the provisions of this Regulation, all or an appropriate selection of the following data shall be presented in the form indicated in appendix 3 to this annex:

- 3.1.1. the co-ordinates of the R point relative to the three-dimensional reference system,
- 3.1.2. the design torso angle,
- 3.1.3. all indications necessary to adjust the seat (if it is adjustable) to the measuring position set out in paragraph 4.3. below.

3.2. Relationship between measured data and design specifications

- 3.2.1. The co-ordinates of the H point and the value of the actual torso angle obtained by the procedure set out in paragraph 4 below shall be compared, respectively, with the co-ordinates of the R point and the value of the design torso angle indicated by the vehicle manufacturer.
- 3.2.2. The relative positions of the R point and the H point and the relationship between the design torso angle and the actual torso angle shall be considered satisfactory for the seating position in question if the H point, as defined by its co-ordinates, lies within a square of 50 mm side with horizontal and vertical sides whose diagonals intersect at the R point, and if the actual torso angle is within 5° of the design torso angle.
- 3.2.3. If these conditions are met, the R point and the design torso angle shall be used to demonstrate compliance with the provisions of this Regulation.

- 3.2.4. If the H point or the actual torso angle does not satisfy the requirements of paragraph 3.2.2. above, the H point and the actual torso angle shall be determined twice more (three times in all). If the results of two of these three operations satisfy the requirements, the conditions of paragraph 3.2.3. above shall apply.
- 3.2.5. If the results of at least two of the three operations described in paragraph 3.2.4. above do not satisfy the requirements of paragraph 3.2.2. above, or if the verification cannot take place because the vehicle manufacturer has failed to supply information regarding the position of the R point or regarding the design torso angle, the centroid of the three measured points or the average of the three measured angles shall be used and be regarded as applicable in all cases where the R point or the design torso angle is referred to in this Regulation.
4. PROCEDURE FOR DETERMINING THE H POINT AND THE ACTUAL TORSO ANGLE
- 4.1. The vehicle shall be preconditioned at a temperature of $20^{\circ}\text{C} \pm 10^{\circ}\text{C}$, at the manufacturer's discretion, to ensure that the seat material reaches room temperature. If the seat to be checked has never been used, a 70 to 80 kg person or device shall be placed on the seat twice for one minute to flex the cushion and back. At the manufacturer's request, all seat assemblies shall remain unloaded for a minimum period of 30 minutes prior to installation of the 3 DH machine.
- 4.2. The vehicle shall be in the measuring attitude defined in paragraph 2.11. above.
- 4.3. The seat, if adjustable, shall be adjusted first to the rearmost normal driving or riding position, as indicated by the vehicle manufacturer, taking into consideration only the longitudinal adjustment of the seat, excluding seat travel used for purposes other than normal driving or riding positions. Where other modes of seat adjustment exist (vertical, angular, seat-back, etc. these will be then adjusted to the position specified by the vehicle manufacturer. For suspension seats, the vertical position shall be rigidly fixed corresponding to a normal driving position as specified by the manufacturer.
- 4.4. The area of the seating position taken up by the 3 DH machine shall be covered by a muslin cotton, of sufficient size and appropriate texture, described as a plain cotton fabric having 18.9 threads per cm^2 and weighing 0.228 kg/m^2 , or knitted or non-woven fabric having equivalent characteristics.
If the test is performed on a seat outside the vehicle, the floor on which the seat is placed shall have the same essential characteristics ^{1/} as the floor of the vehicle in which the seat is intended to be used.
- 4.5. Place the seat and back assembly of the 3 DH machine so that the centre plane of the occupant (CPO) coincides with the centre plane of the 3 DH machine. At the manufacturer's request, the 3 DH machine may be moved inboard with respect to the CPO if the 3 DH machine is located so far outboard that the seat edge will not permit levelling of the 3 DH machine.

^{1/} Tilt angle, height difference with a seat mounting, surface texture, etc.

- 4.6. Attach the foot and lower leg assemblies to the seat-pan assembly, either individually or by using the T-bar and lower leg assembly. The line through the H point sight buttons shall be parallel to the ground and perpendicular to the longitudinal centre plane of the seat.
- 4.7. Adjust the feet and leg positions of the 3 DH machine as follows :
- 4.7.1. Seats for driver and outside front passenger :
- 4.7.1.1. Both feet and leg assemblies shall be moved forward in such a way that the feet take up natural positions on the floor, between the operating pedals if necessary. Where possible the left foot shall be located at approximately the same distance to the left of the centre plane of the 3 DH machine as the right foot is to the right. The spirit level verifying the transverse orientation of the 3 DH machine is brought to the horizontal by readjustment of the seat pan if necessary, or by adjusting the leg and foot assemblies towards the rear. The line passing through the H point sight buttons shall be maintained perpendicular to the longitudinal centre plane of the seat.
- 4.7.1.2. If the left leg cannot be kept parallel to the right leg and the left foot cannot be supported by the structure, move the left foot until it is supported. The alignment of the sight buttons shall be maintained.
- 4.7.2. Outboard rear seats :
- For rear seats or auxiliary seats, the legs are located as specified by the manufacturer. If the feet then rest on parts of the floor which are at different level, the foot which first comes into contact with the front seat shall serve as a reference and the other foot shall be so arranged that the spirit level giving the transverse orientation of the seat of the device indicates the horizontal.
- 4.7.3. Other seats :
- The general procedure indicated in paragraph 4.7.1. above shall be followed, except that the feet shall be placed as specified by the vehicle manufacturer.
- 4.8. Apply lower leg and thigh weights and level the 3 DH machine.
- 4.9. Tilt the back pan forward against the forward stop and draw the 3 DH machine away from the seat-back using the T-bar. Reposition the 3 DH machine on the seat by one of the following methods :
- 4.9.1. If the 3 DH machine tends to slide rearward, use the following procedure : allow the 3 DH machine to slide rearward until a forward horizontal restraining load on the T-bar is no longer required, i.e. until the seat pan contacts the seat-back. If necessary, re-position the lower leg.
- 4.9.2. If the 3 DH machine does not tend to slide rearward, use the following procedure : slide the 3 DH machine rearwards by applying a horizontal rearward load to the T-bar until the seat pan contacts the seat-back (see figure 2 of appendix 1 to this annex).

- 4.10. Apply a 100 +/- 10 N load to the back and pan assembly of the 3 DH machine at the intersection of the hip angle quadrant and the T-bar housing. The direction of load application shall be maintained along a line passing through the above intersection to a point just above the thigh bar housing (see figure 2 of appendix 1 to this annex). Then carefully return the back pan to the seatback. Care must be exercised throughout the remainder of the procedure to prevent the 3 DH machine from sliding forward.
- 4.11. Install the right and left buttock weights and then, alternatively, the eight torso weights. Maintain the 3 DH machine level.
- 4.12. Tilt the back pan forward to release the tension on the back-seat. Rock the 3 DH machine from side to side through a 10° arc (5° to each side of the vertical centre plane) for three complete cycles to release any accumulated friction between the 3 DH machine and the seat.

During the rocking action, the T-bar of the 3 DH machine may tend to diverge from the specified horizontal and vertical alignment. The T-bar must therefore be restrained by applying an appropriate lateral load during the rocking motions. Care should be exercised in holding the T-bar and rocking the 3 DH machine to ensure that no inadvertent exterior loads are applied in a vertical or fore-and-aft direction.

The feet of the 3 DH machine are not to be restrained or held during this step. If the feet change position, they should then be allowed to remain in that attitude.

Carefully return the back pan to the seat-back and check the two spirit levels for zero position. If any movement of the feet has occurred during the rocking operation of the 3 DH machine, they must be repositioned as follows:

Alternately, lift each foot off the floor the minimum necessary amount until no additional foot movement is obtained. During this lifting, the feet are to be free to rotate; no forward or lateral loads are to be applied. When each foot is placed back in the down position, the heel is to be in contact with the structure designed for this.

Check the lateral spirit level for zero position; if necessary, apply a lateral load to the top of the back pan sufficient to level the 3 DH machine's seat pan on the seat.

- 4.13. Holding the T-bar to prevent the 3 DH machine from sliding forward on the seat cushion, proceed as follows :
 - (a) return the back pan to the seat-back,
 - (b) alternately apply and release a horizontal rearward load, not to exceed 25 N, to the back angle bar at a height approximately at the centre of the torso weights until the hip angle quadrant indicates that a stable position has been reached after load release. Care should be taken to ensure that no exterior downward or lateral loads are applied to the 3 DH machine. If another level adjustment of the 3 DH machine is necessary, rotate the back pan forward, re-level, and repeat the procedure from 4.12.
- 4.14. Take all measurements :
- 4.14.1. The co-ordinates of the H point are measured with respect to the three-dimensional reference system.

- 4.14.2. The actual torso angle is read at the back angle quadrant of the 3 DH machine with the probe in its fully rearward position.
- 4.15. If a repetition of the installation of the 3 DH machine is desired, the seat assembly shall remain unloaded for a minimum period of 30 minutes prior to the repetition. The 3 DH machine shall not be left loaded on the seat assembly longer than the time required to perform the test.
- 4.16. If the seats in the same row can be regarded as similar (bench seat, identical seats, etc.) only one H point and one actual torso angle shall be determined for each row of seats, the 3 DH machine described in appendix 1 to this annex being seated in a place regarded as representative for the row.
This place shall be :
- 4.16.1. In the case of the front row, the driver's seat,
- 4.16.2. In the case of the rear row or rows, an outer seat.
-

Annex 16 - Appendix 1

DESCRIPTION OF THE THREE-DIMENSIONAL H POINT MACHINE ^{*/}
(3 DH machine)

1. BACK AND SEAT PANS

The back and seat pans are constructed of reinforced plastics and metal; they simulate the human torso and thighs and are mechanically hinged at the H point. A quadrant is fastened to the probe hinged at the H point to measure the actual torso angle. An adjustable thigh bar, attached to the seat pan, establishes the thigh centreline and serves as a baseline for the hip angle quadrant.

2. BODY AND LEG ELEMENTS

Lower leg segments are connected to the seat pan assembly at the T-bar joining the knees, which is a lateral extension of the adjustable thigh bar. Quadrants are incorporated in the lower leg segments to measure knee angles. shoe and foot assemblies are calibrated to measure the foot angle. Two spirit levels orient the device in space. Body element weights are placed at the corresponding centres of gravity to provide seat penetration equivalent to a 76kg male. All joints of the 3 DH machine should be checked for free movement without encountering any noticeable friction.

^{*/} For details of the construction of the 3 DH machine refer to Society of Automotive Engineers (SAE), 400 Commonwealth Drive, Warrendale, Pennsylvania 15096, United States of America.

The machine corresponds to that described in ISO Standard 6549-1980.

Annex 16 - Appendix 1

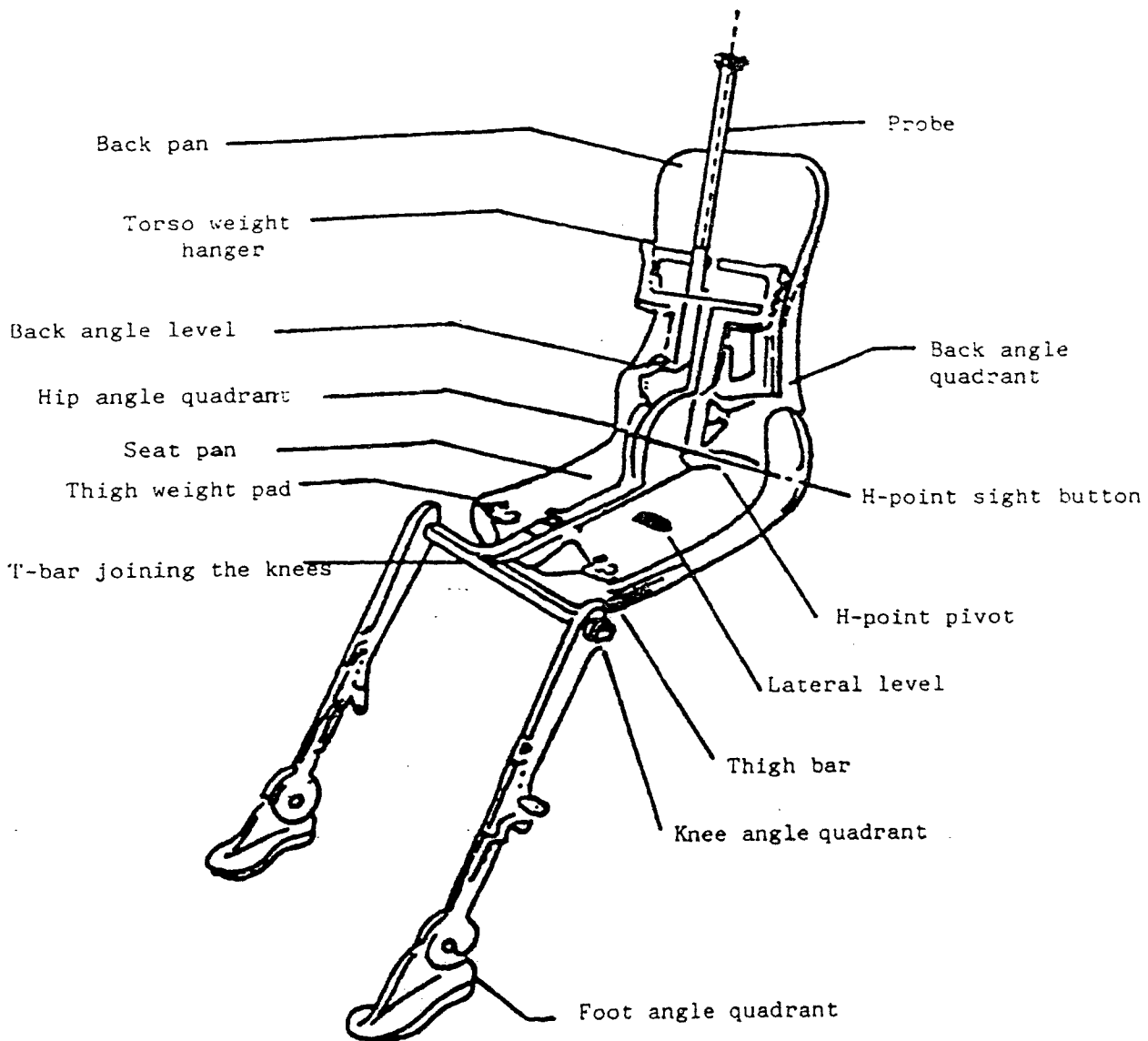

Figure 1 : Designation of 3 DH machine components

Annex 16 - Appendix 1

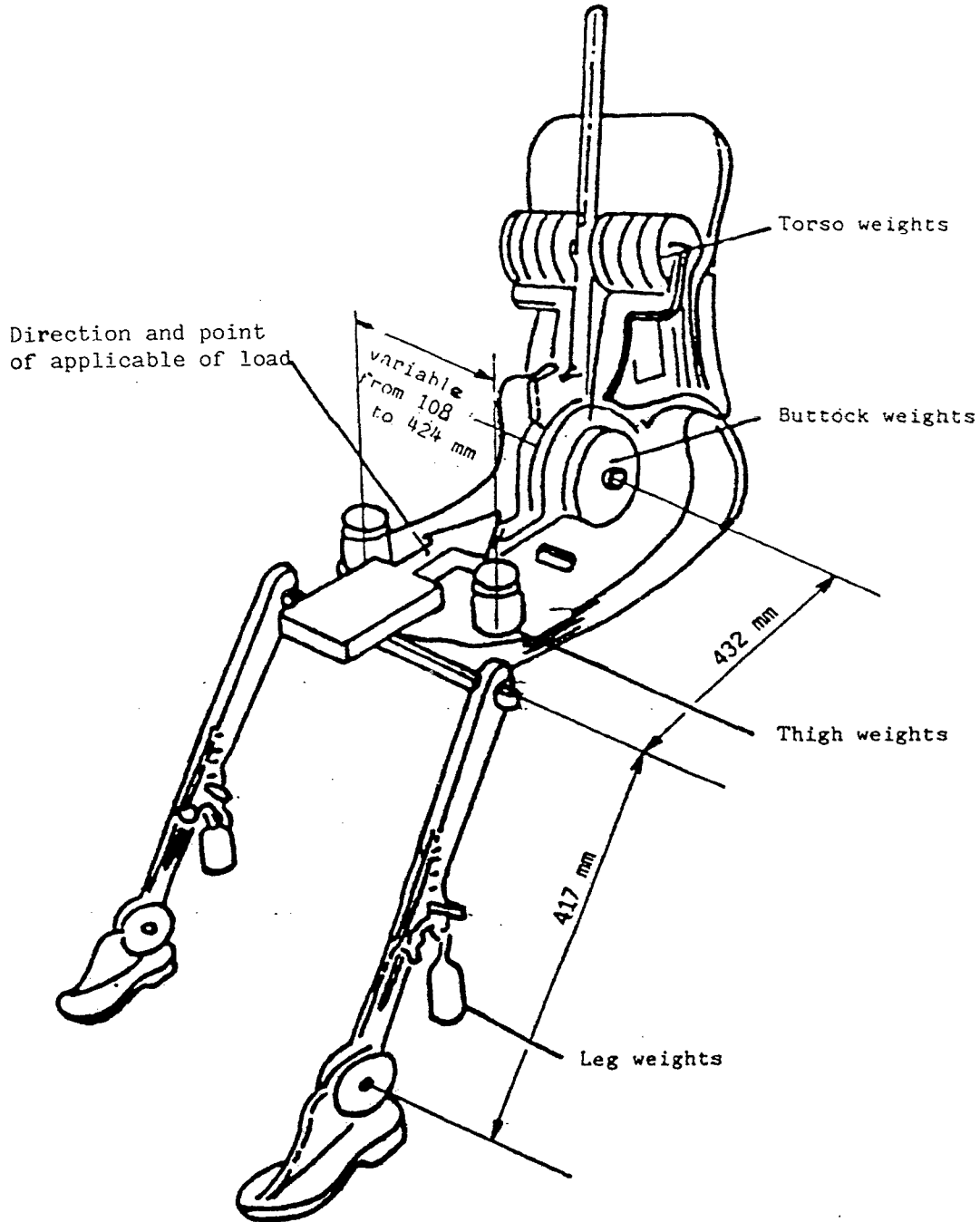

Figure 2 : Dimensions of 3 DH machine components and load distribution

Annex 16 - Appendix 2

THREE-DIMENSIONAL REFERENCE SYSTEM

1. The three-dimensional reference system is defined by three orthogonal planes established by the vehicle manufacturer (see figure).^{*/}
2. The vehicle measuring attitude is determined by positioning the vehicle on a supporting surface such that the co-ordinates of the fiducial marks correspond to the values indicated by the manufacturer.
3. The co-ordinates of the R point and the H point are determined in relation to the fiducial marks defined by the vehicle manufacturer.

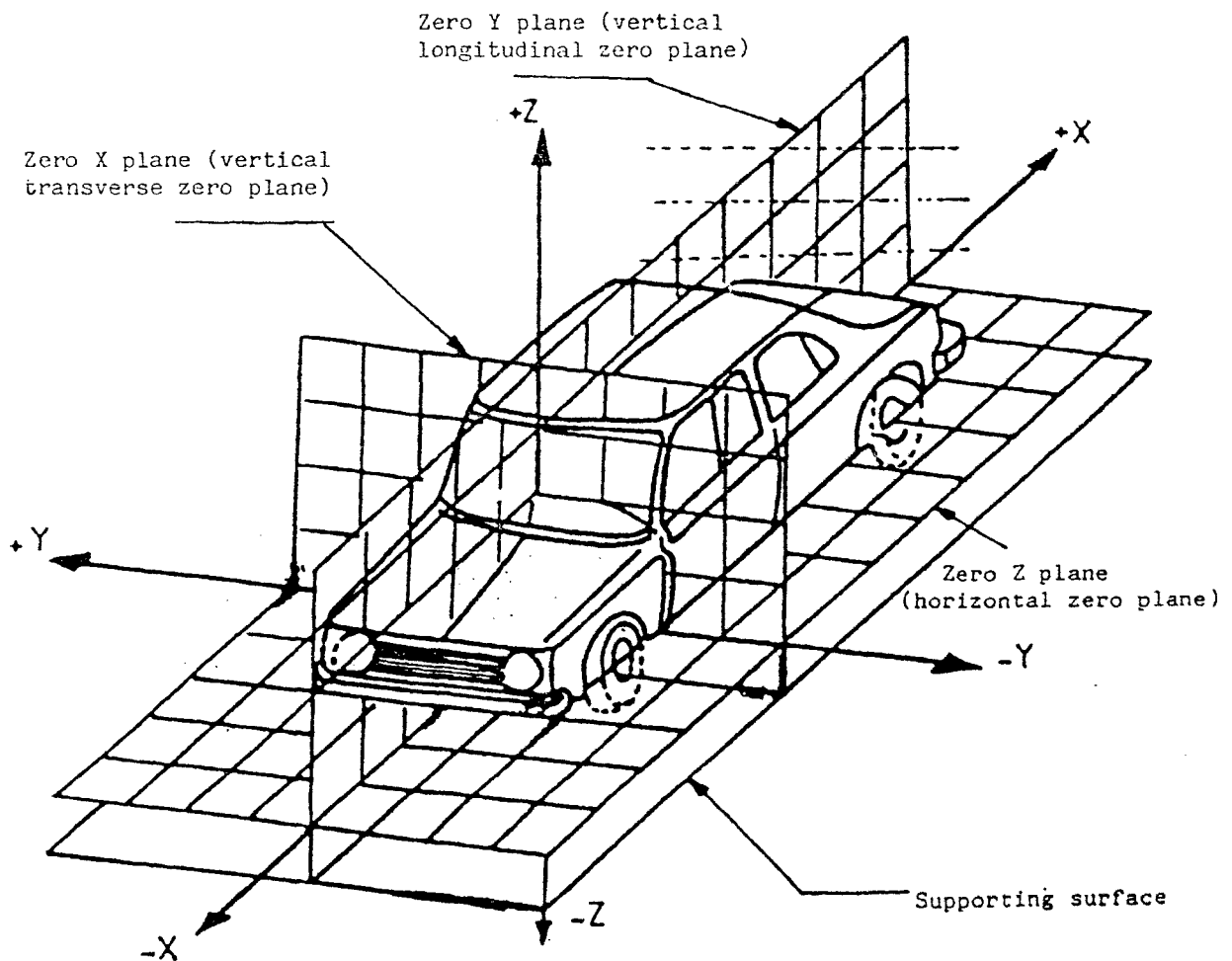

Figure : three-dimensional reference system

^{*/} The reference system corresponds to ISO Standard 4130 - 1978.

Annex 16 - Appendix 3

REFERENCE DATA CONCERNING SEATING POSITIONS

1. CODING OF REFERENCE DATA

Reference data are listed consecutively for each seating position. Seating positions are identified by a two-character code. The first character is an Arabic numeral which designates the row of seats, counting from the front to the rear of the vehicle. The second is a capital letter which designates the location of the seating position in a row, as viewed in the direction of forward motion of the vehicle;
the following letters shall be used :

L = left,
C = centre,
R = right.

2. DESCRIPTION OF VEHICLE MEASURING ATTITUDE

2.1. Co-ordinates of fiducial marks

X
Y
Z

3. LIST OF REFERENCE DATA

3.1. Seating position :

3.1.1. Co-ordinates of the R point :

X
Y
Z

3.1.2. Design torso angle :

3.1.3. Specifications for seat adjustment ^{*/}

horizontal :
vertical :
angular :
torso angle:

NOTE : List reference data for further seating positions under 3.2., 3.3., etc.

^{*/} Strike out what does not apply.

Annex 17

CHECKS ON CONFORMITY OF PRODUCTION

1. DEFINITIONS

For the purpose of this annex:

- 1.1. "Type of product" means all glass panes having the same principal characteristics;
- 1.2. "Thickness class" means all glass panes whose component parts have the same thickness within the permitted tolerances;
- 1.3. "Production unit" means all production facilities of one or several types of glass panes established in the same place; it may include several production lines;
- 1.4. "Shift" means a period of production carried out by the same production line during daily working hours;
- 1.5. "Production run" means a continuous period of production of the same type of product in the same production line;
- 1.6. "Ps" means the number of glass panes of the same type of product produced by the same shift;
- 1.7. "Pr" means the number of glass panes of the same type of product produced during a production run.

2. TESTS

The glass panes shall be subjected to the following tests :

- 2.1. Toughened-glass windscreens
 - 2.1.1. Fragmentation test in accordance with the requirements of annex 4, paragraph 2.
 - 2.1.2. Light transmission measurement in accordance with the requirements of annex 3, paragraph 9.1.
 - 2.1.3. Optical distortion test in accordance with the requirements of annex 3, paragraph 9.2..
 - 2.1.4. Secondary image separation test in accordance with the requirements of annex 3, paragraph 9.3.
- 2.2. Uniformly-toughened glass panes
 - 2.2.1. Fragmentation test in accordance with the requirements of annex 5, paragraph 2.
 - 2.2.2. Light transmission measurement in accordance with the requirements of annex 3, paragraph 9.1.

2.2.3. In the case of glass panes used as windscreens :

2.2.3.1. Optical distortion test in accordance with the requirements of annex 3, paragraph 9.2..

2.2.3.2. Secondary image separation test in accordance with the requirements of annex 3, paragraph 9.3.

2.3. Ordinary laminated-glass windscreens and glass-plastics windscreens

2.3.1. Headform test in accordance with the requirements of annex 6, paragraph 3.

2.3.2. 2,260 g ball test in accordance with the requirements of annex 6, paragraph 4.2. and annex 3, paragraph 2.2.

2.3.3. Test of resistance to high temperature in accordance with the requirements of annex 3, paragraph 5.

2.3.4. Light transmission measurement in accordance with the requirements of annex 3 paragraph 9.1.

2.3.5. Optical distortion test in accordance with the requirements of annex 3, paragraph 9.2..

2.3.6. Secondary image separation test in accordance with the requirements of annex 3, paragraph 9.3.

2.3.7. In the case of glass-plastics windscreens only :

2.3.7.1. Test of resistance to abrasion in accordance with the requirements of annex 9 paragraph 2.1.

2.3.7.2. Resistance-to-humidity test in accordance with the requirements of annex 9, paragraph 3.

2.3.7.3. Test of resistance to chemicals in accordance with the requirements of annex 3, paragraph 11.

2.4. Ordinary laminated-glass and glass-plastics panes other than windscreens

2.4.1. 227 g ball test in accordance with the requirements of annex 7, paragraph 4.

2.4.2. Test of resistance to high temperature in accordance with the requirements of annex 3, paragraph 5.

2.4.3. Light transmission measurement in accordance with the requirements of annex 3, paragraph 9.1.

2.4.4. In the case of glass-plastics panes only :

2.4.4.1. Test of resistance to abrasion in accordance with the requirements of annex 9, paragraph 2.1.

2.4.4.2. Resistance-to-humidity test in accordance with the requirements of annex 9 paragraph 3.

2.4.4.3. Test of resistance to chemicals in accordance with the requirements of annex 3, paragraph 11.

2.4.5. The above provisions shall be considered to be met if the corresponding tests have been carried out on a windscreen of the same composition.

2.5. Treated laminated-glass windscreens

2.5.1. In addition to the tests prescribed in paragraph 2.3. of this annex, a fragmentation test shall be carried out in accordance of annex 8 paragraph 4.

2.6. Glass panes faced with plastics material

In addition to the tests prescribed in the various paragraphs of this the following tests shall be carried out :

2.6.1. Test of resistance to abrasion in accordance with the requirements of annex 9, paragraph 2.1.

2.6.2. Resistance-to-humidity test in accordance with the requirements of annex 9, paragraph 3.

2.6.3. Test of resistance to chemicals in accordance with the requirements of annex 3, paragraph 11.

2.7. Double-glazed units

The tests to be performed are those specified in this annex for each glass pane composing the double-glazed unit, with the same frequency and the same requirements.

3. FREQUENCY OF TESTS AND RESULTS

3.1. Fragmentation test

3.1.1. Tests

3.1.1.1. A first series of tests consisting of a break at each impact point specified by this Regulation shall be carried out with photographic prints at the beginning of the production of each new type of glass pane to determine the most severe break point.

However, for toughened-glass windscreens, this first series of tests shall be carried out only if the annual production of this type of glass pane exceeds 200 units.

3.1.1.2. During the production run the check test shall be carried out using the break point as determined in paragraph 3.1.1.1..

3.1.1.3. A check shall be carried out at the beginning of each production run or following a change of colour.

3.1.1.4. During the production run the check tests shall be carried out at the following minimum frequency :

Toughened-glass windscreens	Toughened-glass panes other than windscreens	Treated laminated- glass windscreens
Ps ≤ 200 : one break per production run	Pr ≤ 500 : one per shift	0.1 per cent per type
Ps > 200 : One break every four hours of production	Pr > 500 : two per shift	

3.1.1.5. A check shall be carried out at the end of the production run on one of the last glass panes manufactured.

3.1.1.6. For Pr < 20, only one fragmentation test per production run shall be carried out.

3.1.2. Results

All results shall be recorded, including the results without photographic print.

In addition, a photographic contact print shall be made once per shift, except for Pr < 500. In this last case only one photographic contact print shall be made per production run.

3.2. Headform test

3.2.1. Tests

The check shall be carried out on samples corresponding to at least 0.5 per cent of the daily production of laminated-glass windscreens of one production line. A maximum of 15 windscreens per day shall be tested.

The choice of samples shall be representative of the production of the various types of windscreen.

As an alternative and with the agreement of the administrative service, these tests may be replaced by the 2,260 g ball test (see paragraph 3.3. below). Behaviour under head impact shall in any event be checked on at least two samples for each thickness class per year.

3.2.2. Results

All results shall be recorded.

3.3. 2,260 g ball-impact test

3.3.1. Tests

The minimum frequency for the check shall be one complete test per month for each thickness class.

3.3.2. Results

All results shall be recorded.

3.4. 227 g ball-impact test

3.4.1. Tests

The test pieces shall be cut from samples. However, for practical reasons, the tests may be carried out on finished products or parts of them.

The check shall be carried out on a sampling corresponding to at least 0.5 per cent of the production of one shift with a maximum of ten samples per day.

3.4.2 Results

All results shall be recorded.

3.5. Test of resistance to high temperature

3.5.1. Tests

The test pieces shall be cut from samples. However, for practical reasons, the tests may be carried out on finished products or parts of them. These shall be selected so that all interlayers are tested proportionately to their use.

The check shall be carried out on at least three samples per colour of interlayer taken from the daily production.

3.5.2. Results

All results shall be recorded.

3.6. Light transmission

3.6.1. Tests

Representative samples of tinted finished products shall be subjected to this test.

The check shall be carried out at least at the beginning of every production run if there is any change in the characteristics of the glass pane affecting the results of the test.

Glass panes having a regular light transmission measured during type-approval of not less than 80 per cent in the case of windscreens and not less than 75 per cent in the case of glass panes other than windscreens, and glass panes whose symbol is V (see paragraph 5.5.2. of this Regulation), shall be exempted from this test.

Alternatively, for toughened-glass panes, a certificate of compliance with the above requirements may be submitted by the glass supplier.

3.6.2. Results

The value of regular light transmission shall be recorded. In addition, for windscreens with shade-bands or obscuration bands, it shall be verified, from the drawings referred to in paragraph 3.2.1.2.2.4. of this Regulation, that such bands are outside zone B or zone I according to the category of vehicle for which the windscreen is intended.

3.7. Optical distortion and separation of secondary image

3.7.1. Tests

Every windscreen shall be inspected for visual defects. In addition, using the methods specified in this Regulation or any method giving similar results, measurements shall be made in the various areas of vision at the following minimum frequencies :

either where $P_s \leq 200$, one sample per shift,
or, where $P_s > 200$, two samples per shift,
or 1 per cent of the whole production, the samples chosen being representative of all production.

3.7.2. Results

All results shall be recorded.

3.8. Test of resistance to abrasion

3.8.1. Tests

Plastics-surfaced and glass-plastics panes only shall be submitted to this test. There shall be at least one check per month and per type of plastics material surfacing or plastics material acting as an interlayer.

3.8.2. Results

The measurement of the light scatter shall be recorded.

3.9.- Resistance-to-humidity test

3.9.1. Tests

Plastics-surfaced and glass-plastics panes only shall be submitted to this test. There shall be at least one check per month and per type of plastics material surfacing or plastics material acting as an interlayer.

3.9.2. Results

All results shall be recorded.

3.10. Test of resistance to chemicals

3.10.1. Tests

Plastics-surfaced and glass-plastics panes only shall be submitted to this test. There shall be at least one check per month and per type of plastics material surfacing or plastics material acting as an interlayer.

3.10.2. Results

All results shall be recorded.