



**Economic and Social
Council**

Distr.

GENERAL

TRANS/WP.29/649
16 February 1999

ENGLISH

Original: ENGLISH
and FRENCH

ECONOMIC COMMISSION FOR EUROPE

INLAND TRANSPORT COMMITTEE

Working Party on the Construction of Vehicles

DRAFT SUPPLEMENT 17 TO THE 03 SERIES OF AMENDMENTS
TO REGULATION No. 37

(Filament lamps)

Note: The text reproduced below was adopted by the Administrative Committee (AC.1) of the amended 1958 Agreement at its tenth session, following the recommendation by the Working Party at its one-hundred-and-sixteenth session. It is based on document TRANS/WP.29/1998/51, as amended by the Working Party (TRANS/WP.29/640, para. 160).

Contents, Annex 1, amend to read (deleting also sheets S4 and inserting a new footnote */)

"Annex 1

Sheets R2
Sheets H1
Sheets H2
Sheets H3
Sheets H4
Sheets P21W (only for signalling lamps)
Sheet P21/4W (only for signalling lamps)
Sheets P21/5W (only for signalling lamps)
Sheet R5W (only for signalling lamps)
Sheet R10W (only for signalling lamps)
Sheet C5W (only for signalling lamps)
Sheets C21W (only for signalling lamps)
Sheet T4W (only for signalling lamps)
Sheet W5W (only for signalling lamps)
Sheet W3W (only for signalling lamps)
Sheets S1 and S2
Sheet S3
Sheets HS1
Sheets HS2
Sheets PY21W (only for signalling lamps)
Sheet H6W (only for signalling lamps)
Sheets HB3
Sheets HB4
Sheet T1.4W (only for signalling lamps)
Sheets H7
Sheets H27W/1 and H27W/2
Sheets P27W (only for signalling lamps)
Sheets P27/7W (only for signalling lamps)
Sheet WY5W (only for signalling lamps)
Sheets H21W (only for signalling lamps)
Sheets W21W (only for signalling lamps)
Sheets W21/5W (only for signalling lamps)
Sheets W2.3W (only for signalling lamps)
Sheets H8
Sheets W16W (only for signalling lamps)
Sheets HIR1 */
Sheets PY27/7W (only for signalling lamps)
Sheets HIR2
Sheets H9 */
Sheets H10
Sheets H11
Sheets H12

*/ HIR1 and/or H9 filament lamps shall only be permitted to produce passing beam in conjunction with the installation of headlamp cleaning device(s) conforming to Regulation No. 45. In addition, with respect to vertical inclination, the provision of paragraph 6.2.6.2.2. of Regulation No. 48, 01 series of amendments, shall not be applied when these lamps are installed.

This restriction shall apply as long as there is no general agreement on the use of levelling devices and headlamp cleaners with respect to the level of the performance of the headlamp."

The text of the Regulation,

Annex 1,

Sheets S4, should be deleted.

Sheet PY21W/1 (existing), replace by the new sheet PY21W/1.

Add at the end new sheets H12/1 to H12/3, to read:

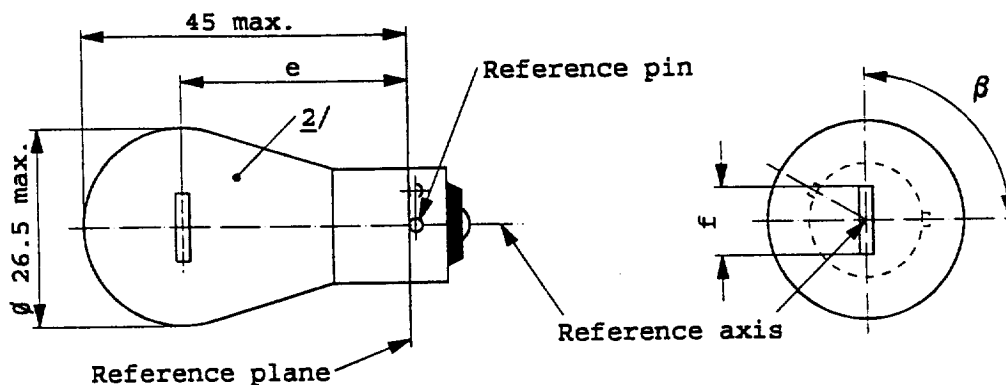

DIMENSIONS in mm	Filament lamps of normal production			Standard filament lamp	
	min.	nom.	max.		
e		31.8 <u>3/</u>		31.8 ± 0.3	
f <u>4/</u>			7.0	7.0 ^{+ 0} _{- 2}	
Lateral deviation <u>1/</u>		<u>3/</u>		0.3 max.	
β	75°	90°	105°	90° ± 5°	
Cap BAU15s in accordance with IEC Publ. 61 (sheet 7004-19-1)					
ELECTRICAL AND PHOTOMETRIC CHARACTERISTICS					
Rated values	V	12	24	12	
	W	21		21	
Test voltage	V	13.5	28.0		
Objective values	Watts	W	26.5 max.	29.7 max.	26.5 max at 13.5V
	Luminous flux	lm	280		
		±%	20		
Reference luminous flux :		Amber bulb: 280 lm Clear bulb: 460 lm			at approx. 13.5 V

- 1/ Maximum lateral deviation of filament centre from two mutually perpendicular planes both containing the reference axis and one containing the axis of the reference pin
- 2/ The bulb of production lamps shall be amber. (See also note 5/).
- 3/ To be checked by means of a box system, sheet PY21W/2.
- 4/ For 24-Volt heavy-duty lamps having a different filament shape, additional specifications are under consideration.
- 5/ The bulb of standard filament lamps shall be amber or clear. For amber standard filament lamps, changes of the bulb temperature shall not affect the luminous flux which might impair photometric measurements of signalling devices. Moreover the colour shall be in the lower part of the tolerance area.

Screen projection requirements

This test is used to determine, by checking whether the filament is correctly positioned relative to the reference axis and the reference plane and has an axis perpendicular, within $\pm 15^\circ$, to the plane through the centre line of the reference pin and the reference axis, whether a filament lamp complies with the requirements.

Side elevation

Front elevation

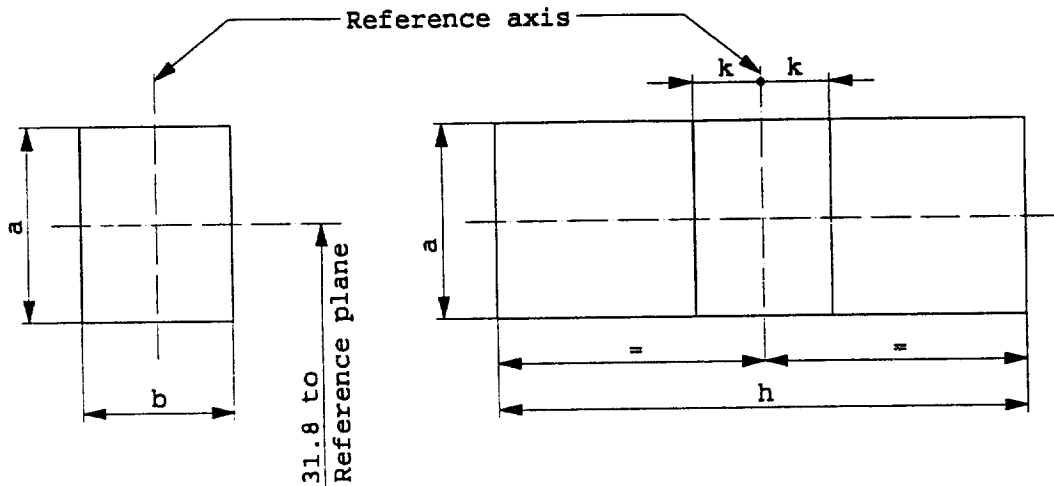

Reference	a	b	h	k
Dimension	3.5	3.0	9.0	1.0

Test procedures and requirements.

1. The filament lamp is placed in a holder capable of being rotated about its axis and having either a calibrated scale or fixed stops corresponding to the angular displacement tolerance limits. The holder is then so rotated that an end view of the filament is seen on the screen on to which the image of the filament is projected. The end view of the filament shall be obtained within the angular displacements tolerance limits.
2. Side elevation
The filament lamp placed with the cap down, the reference axis vertical and the filament seen end-on, the projection of the filament shall lie entirely within a rectangle of height "a" and width "b", having its centre at the theoretical position of the centre of the filament.
3. Front elevation
The filament lamp placed with the cap down and the reference axis vertical, the filament lamp being viewed in a direction at right angles to the filament axis:
 - 3.1 The projection of the filament shall lie entirely within a rectangle of height "a" and width "h", having its centre at the theoretical position of the centre of the filament.
 - 3.2 The centre of the filament shall not be offset by more than distance "k" from the reference axis.

The drawings are only to illustrate the essential dimensions of the filament lamp

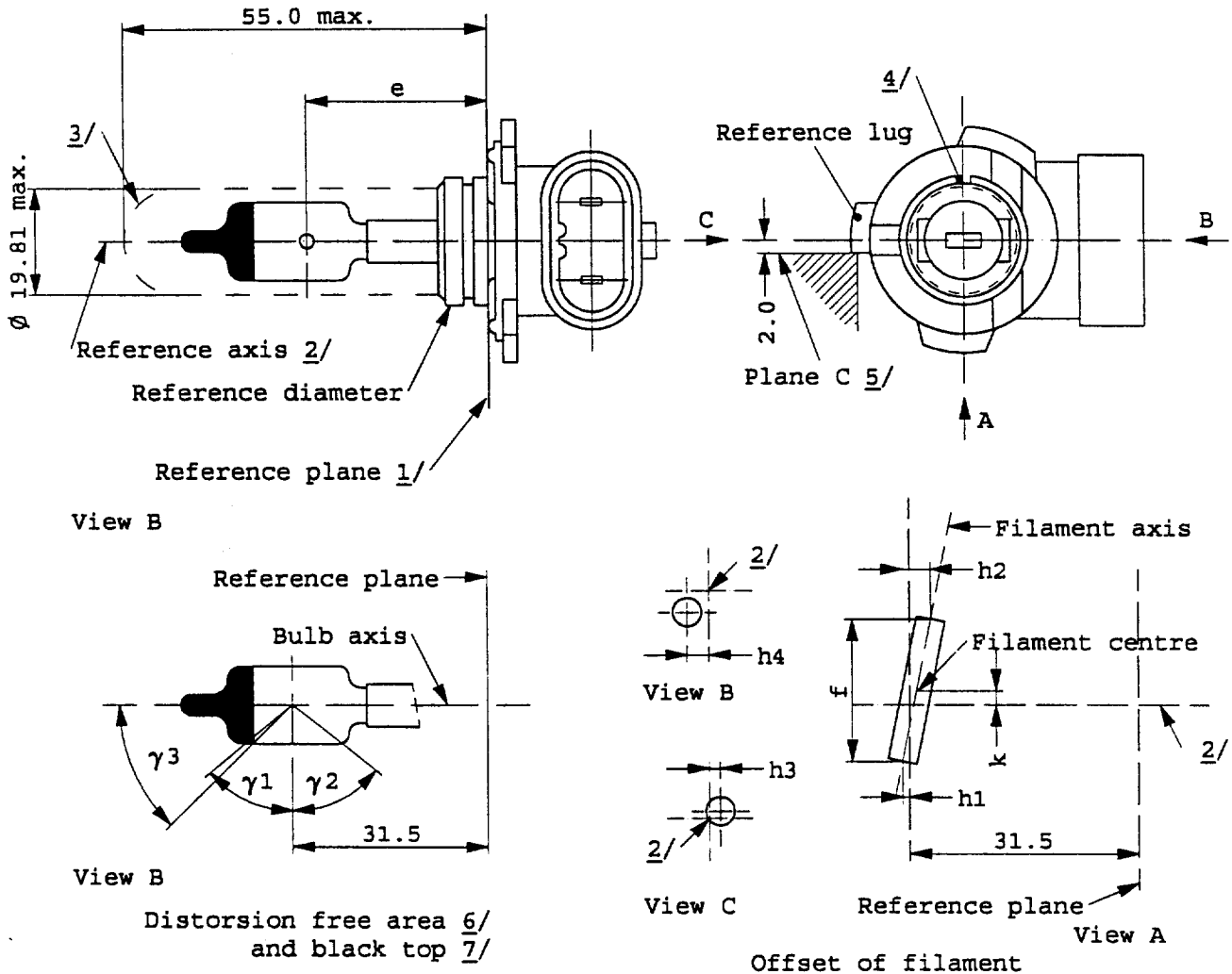

- 1/ The reference plane is the plane defined by the meeting points of the cap-holder fit.
- 2/ The reference axis is perpendicular to the reference plane and concentric with the reference diameter of the cap.
- 3/ Glass bulb and supports shall not exceed the envelope and shall not interfere with insertion past the lamp key. The envelope is concentric to the reference axis.
- 4/ The keyway is mandatory.
- 5/ The filament lamp shall be rotated in the measuring holder until the reference lug contacts plane C of the holder.
- 6/ Glass bulb periphery shall be optically distortion-free axially within the angles γ_1 and γ_2 . This requirement applies to the whole bulb circumference within the angles γ_1 and γ_2 .
- 7/ The obscuration shall extend to at least angle γ_3 and shall be at least as far as the undistorted part of the bulb defined by angle γ_1 .

CATEGORY H12

Sheet H12/2

Dimensions in mm <u>8/</u>		Tolerances	
		Filament lamps of normal production	Standard filament lamp
e	<u>9/ 10/</u> 31.5	<u>11/</u>	± 0.16
f	<u>9/ 10/</u> 5.5	<u>11/</u>	± 0.16
h1, h2, h3, h4	0	<u>11/</u>	± 0.15 <u>12/</u>
k	0	<u>11/</u>	± 0.15 <u>13/</u>
γ_1	50° min.		
γ_2	52° min.		
γ_3	45°	± 5°	± 5°
Cap PZ20d in accordance with IEC Publ. 61 (sheet 7004-31-2)			
ELECTRICAL AND PHOTOMETRIC CHARACTERISTICS			
Rated values	Volts	12	12
	Watts	53	53
Test voltage	Volts	13.2	13.2
Objective values	Watts	61 max.	61 max.
	Luminous flux lm	1050	
	± %	15	
Reference luminous flux: 775 lm at approx. 12V			

- 8/ Dimensions shall be checked with O-ring removed.
- 9/ The viewing direction is direction A as shown in the figure on sheet H12/1.
- 10/ The ends of the filament are defined as the points where, when the viewing direction as defined in note 9/ above, the projection of the outside of the end turns crosses the filament axis.
- 11/ To be checked by means of a "box-system". Sheet H12/3.
- 12/ Dimensions h1 and h2 are measured in viewing direction A, dimension h3 in direction C and dimension h4 in direction B as shown in the figure on sheet H12/1. The points to be measured are those where the projection of the outside of the end turns crosses the filament axis.
- 13/ Dimension k is measured only in viewing direction A.

Screen projection requirements

This test is used to determine, by checking whether the filament is correctly positioned relative to the reference axis and the reference plane, whether a filament lamp complies with the requirements.

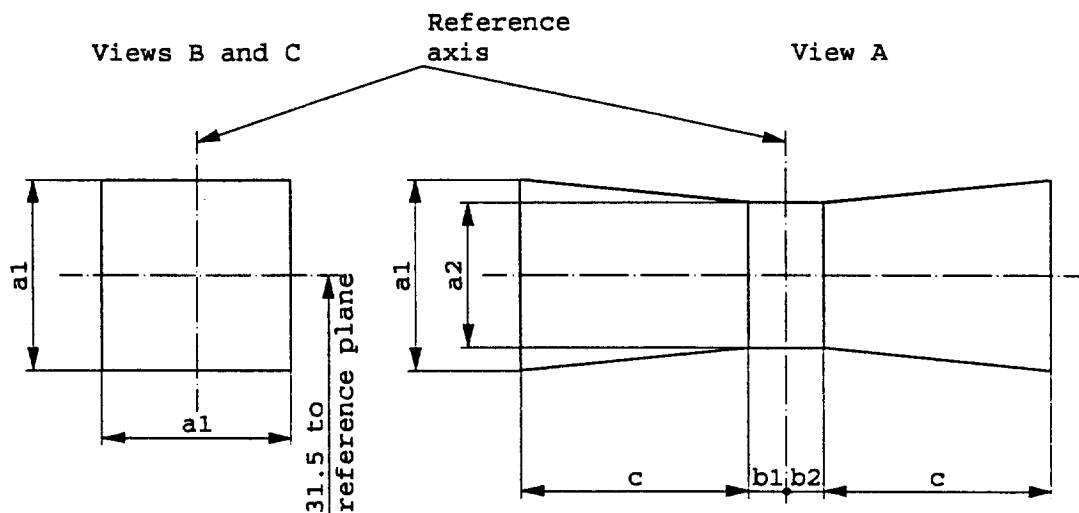

a1	a2	b1	b2	c
1.6 d	1.3 d	0.30	0.30	2.8

d = diameter of filament

For the directions of view A, B and C see sheet H12/1

The filament shall entirely lie within the limits shown.

The center of the filament shall lie between the limits of dimensions b1 and b2.