

3 December 1997

## AGREEMENT

### CONCERNING THE ADOPTION OF UNIFORM TECHNICAL PRESCRIPTIONS FOR WHEELED VEHICLES, EQUIPMENT AND PARTS WHICH CAN BE FITTED AND/OR BE USED ON WHEELED VEHICLES AND THE CONDITIONS FOR RECIPROCAL RECOGNITION OF APPROVALS GRANTED ON THE BASIS OF THESE PRESCRIPTIONS \*/

(Revision 2, including the amendments entered into force on 16 October 1995)

---

#### Addendum 68: Regulation No. 69

#### Amendment 1

Incorporating:

01 series of amendments to the Regulation - Date of entry into force: 27 September 1997

Corrigendum 1 to the 01 series of amendments subject of Depository Notification C.N.226.1997.TREATIES-43 of 20 June 1997

### UNIFORM PROVISIONS CONCERNING THE APPROVAL OF REAR MARKING PLATES FOR SLOW-MOVING VEHICLES (BY CONSTRUCTION) AND THEIR TRAILERS



UNITED NATIONS

---

\*/ Former title of the Agreement:

Agreement Concerning the Adoption of Uniform Conditions of Approval and Reciprocal Recognition of Approval for Motor Vehicle Equipment and Parts, done at Geneva on 20 March 1958.

GE.97-24814

Contents, annexes, in the title of annex 5, amend the words "retroreflective/fluorescent" to read "retro-reflective/fluorescent or retro-reflective only" and insert two new titles, to read:

"Annex 13 - Minimum requirements for conformity of production control procedures

Annex 14 - Minimum requirements for sampling by an inspector"

Text of the Regulation,

General amendment: Throughout the text of the Regulation, amend the words "retroreflective" or "retroreflecting" and/or "retroreflection" to read "retro-reflective" or "retro-reflecting" and/or "retro-reflection", as applicable.

Paragraph 2.1.1., amend to read:

"2.1.1. "SMV rear marking plate", a triangular plate with truncated corners with a characteristic pattern faced with retro-reflective and fluorescent material or devices (class 1); or with retro-reflective materials or devices only (class 2)."

Insert a new paragraph 2.3.12., to read:

"2.3.12. Angle of rotation  $\varepsilon$

Angle through which the sample is turned about its vertical axis from any arbitrarily established position counterclockwise (+ $\varepsilon$ ) or clockwise (- $\varepsilon$ ) viewed in the direction of illumination. If retro-reflective materials or devices have a marking (e.g. TOP), this marking governs the starting position. The angle of rotation  $\varepsilon$  lies in the range  $-180^\circ < \varepsilon \leq 180^\circ$ ."

Paragraph 2.4.1., amend to read:

"2.4.1. Coefficient of retro-reflection R'

Coefficient (R') obtained from the luminous intensity (I) of the retro-reflective area in the direction of observation and the illuminance ( $E_1$ ) on the retro-reflective plane at right angles to the direction of the incident light and the illuminated plane sample surface A.

$$R' = \frac{I}{E_1 \cdot A}$$

The coefficient of retro-reflection R' is expressed in candela per square metre per lux ( $\text{cd} \cdot \text{m}^{-2} \cdot \text{lx}^{-1}$ )."

Paragraph 3.1.4., amend the words "retroreflective and fluorescent" to read "retro-reflective and fluorescent (class 1) or retro-reflective only (class 2)".

Paragraph 4.1.2., amend the words "omni-rotational" to read "for all angles of rotation  $\epsilon$ ".

Paragraph 5.2., amend to read:

"5.2. An approval number shall be assigned to each type approved. Its first two digits (at present 01) shall indicate the series of amendments incorporating the most recent major technical amendments made to the Regulation at the time of issue of the approval. The symbol above the circle indicates the class of SMV rear marking plate, "RF" in the case of class 1 (recto-reflective and fluorescent materials) and "RR" in the case of class 2 (retro-reflective only materials). The same Contracting Party may not assign the same number to another type of SMV rear marking plate."

Paragraph 5.4.1.1., footnote \*/, amend to read:

"\*/ 1 for Germany, ... 8 for the Czech Republic, ... 15 (vacant), ... 22 for the Russian Federation, 23 for Greece, 24 (vacant), 25 for Croatia, 26 for Slovenia, 27 for Slovakia, 28 for Belarus, 29 for Estonia, 30-36 (vacant) and 37 for Turkey. Subsequent numbers ...."

Paragraph 6.2., amend to read:

"6.2. The components of retro-reflective/fluorescent SMV rear marking plates (class 1) or retro-reflective only SMV rear marking plates (class 2) shall not be capable of being easily dismantled."

Paragraph 6.4., amend to read:

"6.4. The outer surface of the retro-reflective/fluorescent SMV rear marking plate (class 1) or retro-reflective only SMV rear marking plate (class 2) shall be easy to clean. The surface shall therefore ...."

Paragraph 8.3., amend to read:

"8.3. The competent authority issuing the extension of approval shall assign a series number for such an extension and inform thereof the other Parties to the 1958 Agreement applying this Regulation by means of a communication form conforming to the model in annex 2 to this Regulation."

Paragraph 9, replace by the following text:

"9. CONFORMITY OF PRODUCTION

The Conformity of production procedures shall comply with those set out in the Agreement, Appendix 2 (E/ECE/324-E/ECE/TRANS/505/Rev.2), with the following requirements:

- 9.1. Rear marking plates approved under this Regulation shall be so manufactured as to conform to the type approved by meeting the requirements set forth in paragraphs 6 and 7.
- 9.2. The minimum requirements for conformity of production control procedures set forth in annex 13 to this Regulation shall be complied with.
- 9.3. The minimum requirements for sampling by an inspector set forth in annex 14 to this Regulation shall be complied with.
- 9.4. The authority which has granted type approval may at any time verify the conformity control methods applied in each production facility. The normal frequency of these verifications shall be once every two years."

Paragraph 10.2., amend to read:

"... the other Contracting Parties applying this Regulation by means of a communication form conforming to the model in annex 2 to this Regulation."

Paragraph 11, amend to read:

"11. PRODUCTION DEFINITELY DISCONTINUED

If the holder of the approval completely ceases the manufacture of an SMV rear marking plate approved in accordance with this Regulation, he shall so inform the authority which granted the approval. Upon receiving the relevant communication, that authority shall inform thereof the other Parties to the Agreement applying this Regulation by means of a communication form conforming to the model in annex 2 to this Regulation."

Insert a new paragraph 12., to read:

"12. TRANSITIONAL PROVISIONS

- 12.1. As from the official date of entry into force of the 01 series of amendments, no Contracting Party applying this Regulation shall refuse to grant approvals under this Regulation as amended by the 01 series of amendments.
- 12.2. As from 12 month after the date of entry into force mentioned in paragraph 12.1. above, Contracting Parties applying this Regulation shall grant approvals only if the requirements of this Regulation, as amended by the 01 series of amendments, are satisfied.

12.3. As from 24 months after the date of entry into force of the 01 series of amendments, Contracting Party applying this Regulation may refuse to recognize approvals which have not been granted in accordance with the 01 series of amendments to this Regulation."

Paragraph 12. (former), renumber as paragraph 13.

Annex 1, figure 1, replace by the following figure:

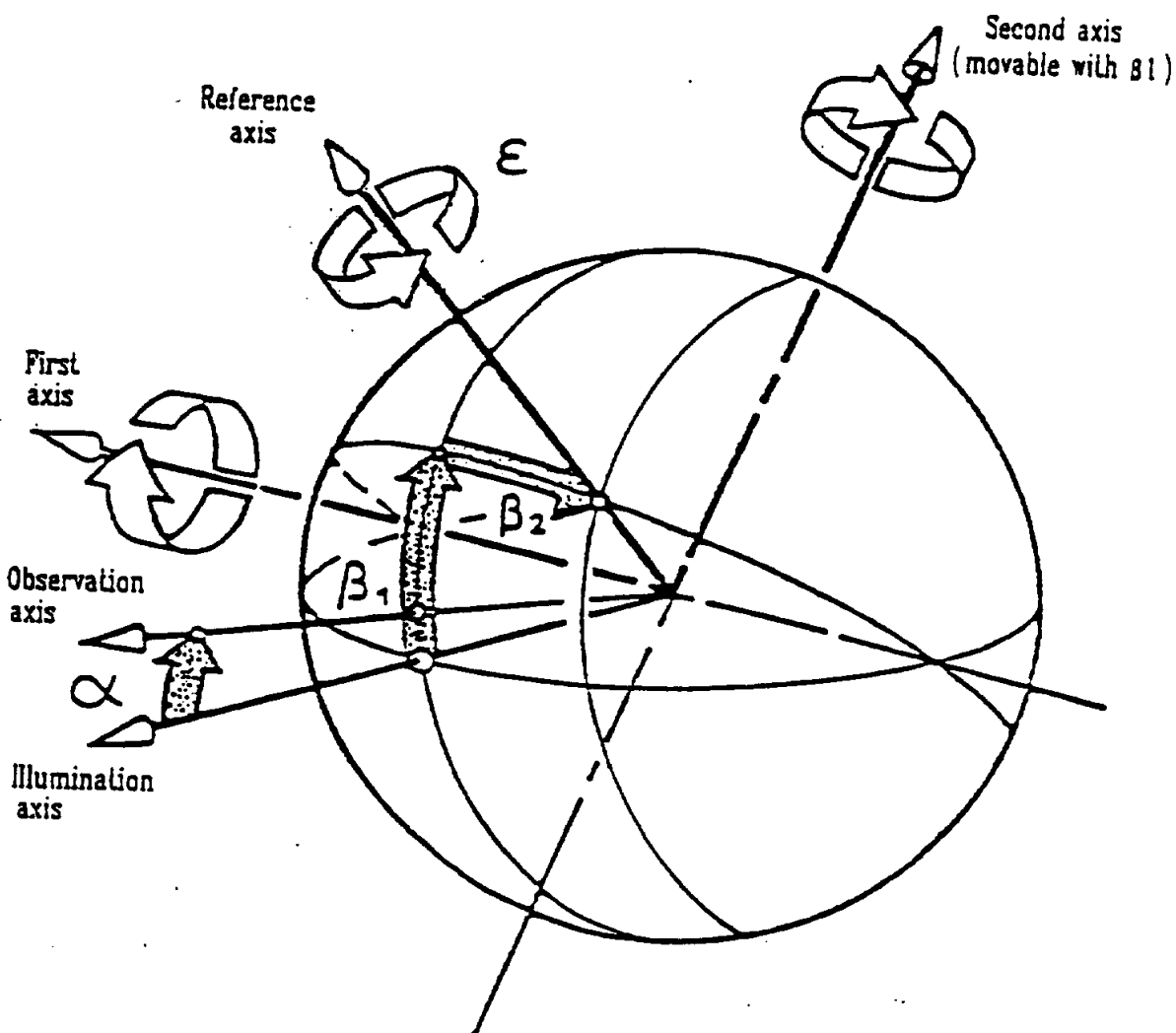

Annex 2, amend to read:

"Annex 2

COMMUNICATION

(maximum format: A4 (210 x 297 mm))



issued by: Name of administration:  
.....  
.....  
.....

- concerning: 2/ APPROVAL GRANTED  
APPROVAL EXTENDED  
APPROVAL REFUSED  
APPROVAL WITHDRAWN  
PRODUCTION DEFINITELY DISCONTINUED

of a type of SMV rear marking plate, pursuant to Regulation No. 69

Approval No.: ..... Extension No.: .....

1. Trade name or mark of the SMV rear marking plate: .....
2. SMV rear marking plate type: .....
- 2.1. SMV rear marking plate class: Class 1/class 2 2/
3. Manufacturer's name and address: .....
- .
- .
- .

---

1/ Distinguishing number of the country which has granted/extended/refused/withdrawn approval (see approval provisions in the Regulation).

2/ ....."

Annex 3, amend to read:

"Annex 3

ARRANGEMENT OF THE APPROVAL MARK

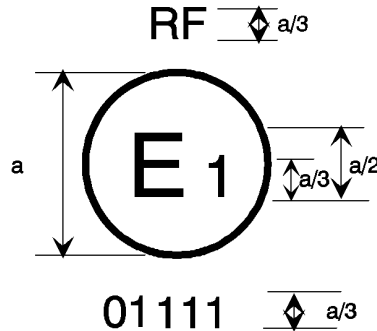

a = 5 mm min.

The SMV rear marking plate bearing the above approval mark has been approved in Germany (E1) under approval number 01111. The first two digits of the approval number indicate that the approval was granted in accordance with the requirements of this Regulation as amended by the 01 series of amendments. Symbol "RF" indicates class 1 SMV rear marking plate (retro-reflective/fluorescent materials). Class 2 (retro-reflective only materials) SMV rear marking plates shall be marked by symbol "RR".

Note: The approval number and the additional symbol must be placed close to the circle and either above or below the letter "E" or to the left or right of that letter. The digits of the approval number must be on the same side of the letter "E" and face in the same direction. The approval number and the additional symbol must be placed diametrically opposite one another. The use of Roman numerals as approval numbers should be avoided so as to prevent any confusion with other symbols.

\_\_\_\_\_ "

Annex 4, paragraph 2, amend the words "retroreflective and fluorescent" to read "retro-reflective and fluorescent (class 1) or retro-reflective only (class 2)".

Annex 5,

The title, amend the words "RETROREFLECTIVE/FLUORESCENT" to read "RETRO-REFLECTIVE/FLUORESCENT (CLASS 1) OR RETRO-REFLECTIVE ONLY (CLASS 2)".

Paragraph 2, amend to read:

- "2. Pattern: The SMV rear marking plates shall have a red fluorescent centre and red retro-reflective borders made of either retro-reflective sheeting or coating or of plastic corner-cube reflectors (class 1). The SMV rear marking plates of class 2 shall have a retro-reflective centre."

Paragraph 3, amend to read:

- "3. Dimensions: The length of the base of the enclosed fluorescent triangle (class 1) or retro-reflective triangle (class 2) shall be: minimum 350 mm and maximum 365 mm. The minimum width of the light-emitting surface of the red retro-reflective border shall be 45 mm, the maximum width 48 mm. These features are illustrated in the example of annex 12."

Annex 6,

Paragraph 1, amend to read:

- "1. SMV rear marking plates for slow-moving vehicles and their trailers shall be composed either of red retro-reflective and red fluorescent materials or devices (class 1) or red retro-reflective only materials or devices (class 2)."

Annex 7,

Paragraph 1, amend to read:

- "1. When illuminated with a CIE Standard Illuminant A and measured as recommended by CIE TC 2.3 (CIE Publication No. 54, 1982), the coefficient of retro-reflection  $R'$  in candelas per square metre per lux ( $\text{cd}\cdot\text{m}^{-2}\cdot\text{lx}^{-1}$ ) of the entire red retro-reflective area in new condition shall be at least as indicated in table 1."

Table 1, replace by the following text:

"Table 1

Coefficient of retro-reflection  $R'$  [ $\text{cd}\cdot\text{m}^{-2}\cdot\text{lx}^{-1}$ ]

Observation angle $\alpha$ [']	Entrance angle $\beta$ [°]				
	$\beta_1$	0°	0°	0°	0°
20'		5°	20°	30°	40°
	$\beta_2$				
R' of the outer border (class 1,2) [ $\text{cd}\cdot\text{m}^{-2}\cdot\text{lx}^{-1}$ ]		120	60	30	10
R' of the enclosed triangle (class 2) [ $\text{cd}\cdot\text{m}^{-2}\cdot\text{lx}^{-1}$ ]		10	7	4	-

The caption below the example, amend to read:

- "(1) Red retro-reflecting material or corner-cube retro-reflector (class 1 or class 2)  
(2) Red fluorescent material (class 1) or red retro-reflecting material (class 2)"



Add new annexes 13 and 14, to read:

"Annex 13

MINIMUM REQUIREMENTS FOR CONFORMITY OF PRODUCTION CONTROL PROCEDURES

1. GENERAL

- 1.1. The conformity requirements shall be considered satisfied from a mechanical and geometric standpoint, if the differences do not exceed inevitable manufacturing deviations within the requirements of this Regulation.
- 1.2. With respect to photometric performances, the conformity of mass-produced rear marking plates shall not be contested if, when testing photometric performances of any rear marking plate chosen at random, no measured value deviates unfavourably by more than 20 per cent from the values prescribed in this Regulation.
- 1.3. The chromaticity coordinates shall be complied with.

2. MINIMUM REQUIREMENTS FOR VERIFICATION OF CONFORMITY BY THE MANUFACTURER

For each type of rear marking plate the holder of the approval mark shall carry out at least the following tests, at appropriate intervals. The tests shall be carried out in accordance with the provisions of this Regulation.

If any sampling shows non-conformity with regard to the type of test concerned, further samples shall be taken and tested. The manufacturer shall take steps to ensure the conformity of the production concerned.

2.1. Nature of tests

Tests of conformity in this Regulation shall cover the photometric and colorimetric characteristics and the test of weather resistance of these characteristics.

2.2. Methods used in tests

- 2.2.1. Tests shall generally be carried out in accordance with the methods set out in this Regulation.

- 2.2.2. In any test of conformity carried out by the manufacturer, equivalent methods may be used with the consent of the competent authority responsible for approval tests. The manufacturer is responsible for proving that the applied methods are equivalent to those laid down in this Regulation.

2.2.3. The application of paragraphs 2.2.1. and 2.2.2. requires regular calibration of test apparatus and its correlation with measurements made by a competent authority.

2.2.4. In all cases the reference methods shall be those of this Regulation, particularly for the purpose of administrative verification and sampling.

2.3. Nature of sampling

Samples of rear marking plates shall be selected at random from the production of a uniform batch. A uniform batch means a set of rear marking plates of the same type, defined according to the production methods of the manufacturer.

The assessment shall in general cover series production from individual factories. However, a manufacturer may group together records concerning the same type from several factories, provided these operate under the same quality system and quality management.

2.4. Measured and recorded photometric characteristics

The sampled rear marking plate shall be subjected to photometric measurements for minimum values at the points and chromaticity coordinates provided for in the Regulation.

2.5. Criteria governing acceptability

The manufacturer is responsible for carrying out a statistical study of the test results and for defining, in agreement with the competent authority, criteria governing the acceptability of his products in order to meet the specifications laid down for verification of conformity of products in paragraph 9.1. of this Regulation.

The criteria governing the acceptability shall be such that, with a confidence level of 95 per cent, the minimum probability of passing a spot check in accordance with annex 14 (first sampling) would be 0.95.

Annex 14

MINIMUM REQUIREMENTS FOR SAMPLING BY AN INSPECTOR

1. GENERAL

1.1. The conformity requirements shall be considered satisfied from a mechanical and a geometric standpoint, in accordance with the requirements of this Regulation, if any, if the differences do not exceed inevitable manufacturing deviations.

- 1.2. With respect to photometric performance, the conformity of mass-produced rear marking plates shall not be contested if, when testing photometric performances of any rear marking plate chosen at random:
- 1.2.1. no measured value deviates unfavourably by more than 20 per cent from the values prescribed in this Regulation.
- 1.2.2. Rear marking plates with apparent defects are disregarded.
- 1.3. The chromaticity coordinates shall be complied with.

2. FIRST SAMPLING

In the first sampling four rear marking plates are selected at random. The first sample of two is marked A, the second sample of two is marked B.

2.1. The conformity is not contested

- 2.1.1. Following the sampling procedure shown in Figure 1 of this annex the conformity of mass-produced rear marking plates shall not be contested if the deviation of the measured values of the rear marking plates in the unfavourable directions are:

2.1.1.1. sample A

A1: one rear marking plate	0 per cent
one rear marking plate not more than	20 per cent
A2: both rear marking plates more than	0 per cent
but not more than	20 per cent
go to sample B	

2.1.1.2. sample B

B1: both rear marking plates	0 per cent
------------------------------	------------

2.2. The conformity is contested

- 2.2.1. Following the sampling procedure shown in Figure 1 of this annex the conformity of mass-produced rear marking plates shall be contested and the manufacturer requested to make his production meet the requirements (alignment) if the deviations of the measured values of the rear marking plates are:

2.2.1.1. sample A

A3: one rear marking plate not more than	20 per cent
one rear marking plate more than	20 per cent
but not more than	30 per cent

2.2.1.2. sample B

B2:	in the case of A2	
	one rear marking plate more than	0 per cent
	but not more than	20 per cent
	one rear marking plate not more than	20 per cent
B3:	in the case of A2	
	one rear marking plate	0 per cent
	one rear marking plate more than	20 per cent
	but not more than	30 per cent

2.3. Approval withdrawn

Conformity shall be contested and paragraph 10 applied if, following the sampling procedure in Figure 1 of this annex, the deviations of the measured values of the rear marking plates are:

2.3.1. sample A

A4:	one rear marking plate not more than	20 per cent
	one rear marking plate more than	30 per cent
A5:	both rear marking plates more than	20 per cent

2.3.2. sample B

B4:	in the case of A2	
	one rear marking plate more than	0 per cent
	but not more than	20 per cent
	one rear marking plate more than	20 per cent
B5:	in the case of A2	
	both rear marking plates more than	20 per cent
B6:	in the case of A2	
	one rear marking plate	0 per cent
	one rear marking plate more than	30 per cent

3. REPEATED SAMPLING

In the cases of A3, B2, B3 a repeated sampling, third sample C of two rear marking plates and fourth sample D of two rear marking plates, selected from stock manufactured after alignment, is necessary within two months time after the notification.

3.1. The conformity is not contested

3.1.1. Following the sampling procedure shown in Figure 1 of this annex the conformity of mass-produced rear marking plates shall not be contested if the deviations of the measured values of the rear marking plates are:

3.1.1.1. sample C

C1:	one rear marking plate	0 per cent
	one rear marking plate not more than	20 per cent
C2:	both rear marking plates more than	0 per cent
	but not more than	20 per cent
	go to sample D	

3.1.1.2. sample D

D1:	in the case of C2	
	both rear marking plates	0 per cent

3.2. The conformity is contested

3.2.1. Following the sampling procedure shown in Figure 1 of this annex the conformity of mass-produced rear marking plates shall be contested and the manufacturer requested to make his production meet the requirements (alignment) if the deviations of the measured values of the rear marking plates are:

3.2.1.1. sample D

D2:	in the case of C2	
	one rear marking plate more than	0 per cent
	but not more than	20 per cent
	one rear marking plate not more than	20 per cent

3.3. Approval withdrawn

Conformity shall be contested and paragraph 10 applied if, following the sampling procedure in Figure 1 of this annex, the deviations of the measured values of the rear marking plates are:

3.3.1. sample C

C3:	one rear marking plate not more than	20 per cent
	one rear marking plate more than	20 per cent
C4:	both rear marking plates more than	20 per cent

3.3.2. sample D

D3:	in the case of C2	
	one rear marking plate 0 or more than	0 per cent
	one rear marking plate more than	20 per cent

4. RESISTANCE TESTS

Specimens of one of the rear marking plates of sample A, after sampling procedure in Figure 1 of this annex, shall be tested according to the procedures described in annexes 8 and 9 to this Regulation.

The rear marking plate shall be considered acceptable if the tests were passed.

However, if the tests on specimens of sample A did not pass the tests, the two rear marking plates of sample B shall be subjected to the same procedure and both shall pass the test.

Figure 1

